



Manual Addendum

Models T320 and T320U ***N₂O Analyzers*** **(Addendum to T300/T300M Manual, PN 06864)**

© TELEDYNE API (TAPI)
9970 CARROLL CANYON ROAD
SAN DIEGO, CA 92131-1106
USA

Toll-free Phone: 800-324-5190
Phone: +1 858-657-9800
Fax: +1 858-657-9816
Email: api-sales@teledyne.com
Website: <http://www.teledyne-api.com/>

SAFETY MESSAGES

Important safety messages are provided throughout this manual. Please read these messages carefully.

A safety message alerts you to potential hazards that could hurt you or others. Each safety message is associated with a safety alert symbol. These symbols are found in the manual and inside the instrument. The definition of these symbols is described below:



WARNING: Electrical Shock Hazard



HAZARD: Strong oxidizer



GENERAL WARNING/CAUTION: Read the accompanying message for specific information.



CAUTION: Hot Surface Warning



Technician Symbol: All operations marked with this symbol are to be performed by qualified maintenance personnel only.



DO NOT TOUCH: Touching some parts of the instrument without protection or proper tools could result in damage to the part(s) and/or the instrument.



Electrical Ground: This symbol inside the instrument marks the central safety grounding point for the instrument.

	<p style="text-align: center;">CAUTION - General Safety Hazard</p> <p>This instrument should only be used for the purpose and in the manner described in this manual. If you use this instrument in a manner other than that for which it was intended, unpredictable behavior could ensue with possible hazardous consequences.</p> <p style="text-align: center;">NEVER use any gas analyzer to sample combustible gas(es).</p>
---	---

<p style="text-align: center;">Note</p> <p>Technical Assistance regarding the use and maintenance of the T320/T320U or any other Teledyne API product can be obtained by contacting Teledyne API's Technical Support Department:</p> <p style="text-align: center;">Phone: 800-324-5190</p> <p style="text-align: center;">Email: sda_techsupport@teledyne.com</p> <p style="text-align: center;">or by accessing various service options on our website at http://www.teledyne-api.com/.</p>

CONSIGNES DE SÉCURITÉ

Des consignes de sécurité importantes sont fournies tout au long du présent manuel dans le but d'éviter des blessures corporelles ou d'endommager les instruments. Veuillez lire attentivement ces consignes. Chaque consigne de sécurité est représentée par un pictogramme d'alerte de sécurité; ces pictogrammes se retrouvent dans ce manuel et à l'intérieur des instruments. Les symboles correspondent aux consignes suivantes:



AVERTISSEMENT : Risque de choc électrique



DANGER : Oxydant puissant



AVERTISSEMENT GÉNÉRAL / MISE EN GARDE : Lire la consigne complémentaire pour des renseignements spécifiques



MISE EN GARDE : Surface chaude



Ne pas toucher : Toucher à certaines parties de l'instrument sans protection ou sans les outils appropriés pourrait entraîner des dommages aux pièces ou à l'instrument.



Pictogramme « technicien » : Toutes les opérations portant ce symbole doivent être effectuées uniquement par du personnel de maintenance qualifié.



Mise à la terre : Ce symbole à l'intérieur de l'instrument détermine le point central de la mise à la terre sécuritaire de l'instrument.

MISE EN GARDE



Cet instrument doit être utilisé aux fins décrites et de la manière décrite dans ce manuel. Si vous utilisez cet instrument d'une autre manière que celle pour laquelle il a été prévu, l'instrument pourrait se comporter de façon imprévisible et entraîner des conséquences dangereuses.

NE JAMAIS utiliser un analyseur de gaz pour échantillonner des gaz combustibles!

TABLE OF CONTENTS

1. INTRODUCTION	5
2. SPECIFICATIONS, APPROVALS AND WARRANTY	7
2.1. Specifications	7
2.2. EPA Equivalency Designation	8
2.3. CE Mark Compliance	8
2.4. Warranty.....	8
3. GETTING STARTED	9
3.1. Unpacking the T320/T320U.....	9
3.2. Initial Operation of the T320/T320U	9
3.3. Functional Check.....	9
3.4. Initial Calibration.....	10
3.4.1. Calibration Gases	10
3.4.2. Internal Pneumatic Flow	11
3.4.3. Pneumatic Connections to T320/T320U Basic Configuration:.....	12
3.4.4. Pneumatic Connections to T320/T320U with Internal Valve Options Installed	13
3.4.5. Pneumatic Connections to T320/T320U in Multipoint Calibration Applications.....	14
4. FREQUENTLY ASKED QUESTIONS & GLOSSARY	15
5. OPTIONAL HARDWARE AND SOFTWARE	17
5.1. Calibration Valve Options for the T320/T320U	17
5.1.1. Zero/Span with common Shutoff valves (Option 50G).....	18
6. BASIC OPERATION	19
6.1. Test Functions.....	19
6.1.1. Selecting a Test Channel Function for Output A4.....	20
7. ADVANCED FEATURES	21
8. REMOTE OPERATION	23
8.1.1. Hessen Protocol	23
9. CALIBRATION PROCEDURES	25
10. EPA PROTOCOL CALIBRATION	27
11. PRINCIPLES OF OPERATION	29
12. MAINTENANCE SCHEDULE	31
13. TROUBLESHOOTING & SERVICE	33

LIST OF FIGURES

Figure 3-1. T320 Pneumatic Flow	11
Figure 3-2. T320U Pneumatic Flow.....	11
Figure 3-2. Pneumatic Connections, Basic Configuration Using Gas Dilution Calibrator	12
Figure 3-3. Pneumatic Connections, Basic Configuration Using Bottled Span Gas	12
Figure 3-4. Pneumatics: Option Z/S Valve with Shutoff Valve for Pressurized Span and Atmospheric Zero.....	13
Figure 3-5. Pneumatics: Option Z/S without Shutoff Valve	13
Figure 3-6. Pneumatics: Option Z/S Valve with Common Shutoff Valve for Pressurized Zero and Span	14
Figure 5-1. Internal Pneumatic Flow, Option Zero/Span with Common Shutoff Valves	18

LIST OF TABLES

Table 2-1. T320/T320U Basic Unit Specifications.....	7
Table 5-1. T320/T320U Available Valve Options	17
Table 5-2. Zero/Span/Shutoff Valve Operating States for Option 50G	18
Table 6-1. Test Functions Defined	19
Table 6-2. Test Channels Functions Available on the T320/T320U's Analog Output.....	20

LIST OF APPENDICES

APPENDIX A – MENU TREES and SOFTWARE DOCUMENTATION

APPENDIX B –SPARE PARTS LIST

APPENDIX C - REPAIR QUESTIONNAIRE

APPENDIX D - SCHEMATICS

1. INTRODUCTION

The T320 and T320U are Gas Filter Correlation (GFC) analyzers that are designed to measure low level and trace level nitrous oxide (N_2O), respectively. The primary difference between the models is their maximum operating range; 1000 ppm for the T320 and 200 ppm for the T320U. The T320 and T320U are designed to be used for monitoring background levels of N_2O in the atmosphere, byproducts of combustion products and contamination of bottled gases.

This addendum is a supplement to the T300/T300M manual (P/N 06864) to facilitate setup, operation, calibration, troubleshooting and repair of T320 and T320U nitrous oxide (N_2O) analyzers. Most of the basic set up information, operating instructions as well as maintenance, troubleshooting and repair methods are the same for the T320/T320U and can be found in the T300/T300M manual (P/N 06864). The T320 is very similar to the T300M, and the T320U is very similar to the T300:

T320 = T300M T320U = T300

When using the T300/T300M manual, it is necessary to substitute the words *nitrous oxide* for *carbon monoxide* and the chemical abbreviation N_2O for CO :

Carbon Monoxide → Nitrous Oxide CO → N_2O

There are six major differences between the T320/T320U and their counterpart models, T300M/T300:

- **Operating wavelength:** A different photo detector is used that closely matches the peak absorption wavelength of N_2O .
- **Gas Filter Correlation Filter (GFC) wheel:** The GFC wheel is filled with N_2O rather than CO to correlate properly with N_2O .
- **Software:** Display text strings, variable names and variable values reflect the difference in gas name and physical characteristic. Wherever “CO” is displayed on the T300/T300M “ N_2O ” will be displayed on the T320/T320U.
- **Calibration Methods:** There are no specialized USEPA calibration methods since these methods currently do not exist.
- **Calibration Gases:** Since there are no readily available low cost N_2O scrubbers and traditional zero air generators like the TAPI model 701, which do not remove N_2O , zero gas must be either N_2 or synthetic air - especially for the T320U.
- **Calibration Valve Options:** Due to there being no N_2O scrubbers or traditional zero air generators for either the T320 or the T320U, Options 51B and 51C for the T300M and T300 are not available for the T320 or T320U.

NOTE

The information contained in this addendum is relevant to T320/T320U analyzers, some of which may not be applicable to the current version of software.

This page intentionally left blank.

2. SPECIFICATIONS, APPROVALS AND WARRANTY

This section provides the specifications for the T320 and the T320U analyzers, and references approvals and warranty.

2.1. SPECIFICATIONS

Specifications differ between the T320 and the T320U analyzers for Ranges, Noise, Lower Detectable Limit and Drift.

Table 2-1. T320/T320U Basic Unit Specifications

Parameter	Model T320	Model T320U	
Ranges	Min:	0-1 ppm Full scale	0-200 ppb Full scale
	Max:	0-1000 ppm Full scale (selectable, dual ranges and auto ranging supported)	0-200 ppm Full scale (selectable, dual ranges and auto ranging supported)
Measurement Units	ppb, ppm, $\mu\text{g}/\text{m}^3$, mg/m^3 (selectable)		
Zero Noise ^{1,2}	< 0.02 ppm (RMS)	< 5 ppb (RMS)	
Span Noise ^{1,2,3}	< 0.5% of reading RMS over 8 ppm	< 0.5% of reading RMS over 2 ppm	
Lower Detectable Limit ^{1,2}	< 0.04 ppm	< 10 ppb	
Zero Drift (24 hours) ²	< 0.1 ppm	< 25 ppb	
Span Drift (24 hours) ^{2,4}	< 0.5% of reading	< 0.5% of reading	
Lag Time ¹	<10 sec		
Rise/Fall Time ¹	<60 sec to 95%		
Linearity ⁶	1% of full scale		
Precision ^{1,5}	0.5% reading		
Sample Flow Rate	800 cm^3/min . \pm 10%		
Voltage Coefficient	< 0.05 % of reading per V		
Power Requirements	100V-120V, 220V-240V, 50/60 Hz		
Analog Output Ranges	10V, 5V, 1V, 0.1V (selectable)		
Recorder Offset	\pm 10%		
Analog Output Resolution	1 part in 4096 of selected full-scale voltage		
Included I/O	1 Ethernet: 10/100Base-T 2 RS-232 (300 – 115,200 baud) 2 USB device ports 8 opto-isolated digital status outputs 6 opto-isolated digital control inputs 4 analog outputs		
Optional I/O	1 USB com port 1 RS485 8 analog inputs (0-10V, 12-bit) 4 digital alarm outputs Multidrop RS232 3 4-20mA current outputs		

Parameter	Model T320	Model T320U
Temperature Range	5 - 40°C operating	
Humidity Range	0-95% RH, Non-Condensing	
Dimensions (HxWxD)	7" x 17" x 23.5" (178 mm x 432 mm x 597 mm)	
Weight	50 lb (22.7 kg)	
Environmental Conditions	Installation Category (Over voltage Category) II Pollution Degree 2	
Certifications	CE: IEC 61010-1:2001 North American: cNEMKO (Canada): CAN/CSA-C22.2 No. 61010-1-04 NEMKO-CCL (US): UL No. 61010-1 (2 nd Edition)	
¹ As defined by the USEPA	⁴ Or 10 ppb, whichever is greater	
² At constant temperature and sample pressure	⁵ Or LDL whichever is greater	
³ Or 20 ppb, whichever is greater	⁶ For values greater than twice the LDL	

2.2. EPA EQUIVALENCY DESIGNATION

There is no US EPA reference method for the measurement of nitrous oxide; therefore, neither the T320 nor the T320U are designated as reference or equivalent methods. Hence, the EPA Protocol Calibration section of the Model T300/T300M Operation Manual does not apply.

2.3. CE MARK COMPLIANCE

See the CE Mark Compliance section of the T300/T300M manual (P/N 06864).

2.4. WARRANTY

See the Warranty page of the T300/T300M manual (P/N 06864).

3. GETTING STARTED

3.1. UNPACKING THE T320/T320U

Follow the unpacking directions in the Getting Started section of the T300/T300M manual (P/N 06864); note that the *Final Test and Validation Data Sheet* for the T320 or the T320U are unique.

3.2. INITIAL OPERATION OF THE T320/T320U

The analyzer should be started and allowed to warm up; a functional check followed by calibration should be performed. The process for starting and warming up the T320/T320U is identical to that described in the Initial Operation section of the T300/T300M Operators Manual (P/N 06864).

3.3. FUNCTIONAL CHECK

The functional check information also in the Initial Operation section of the T300/T300M Operators Manual (P/N 06864) is applicable to the T320/T320U with the following exception(s).

The Test functions available from the front panel of the T320 or T320U are:

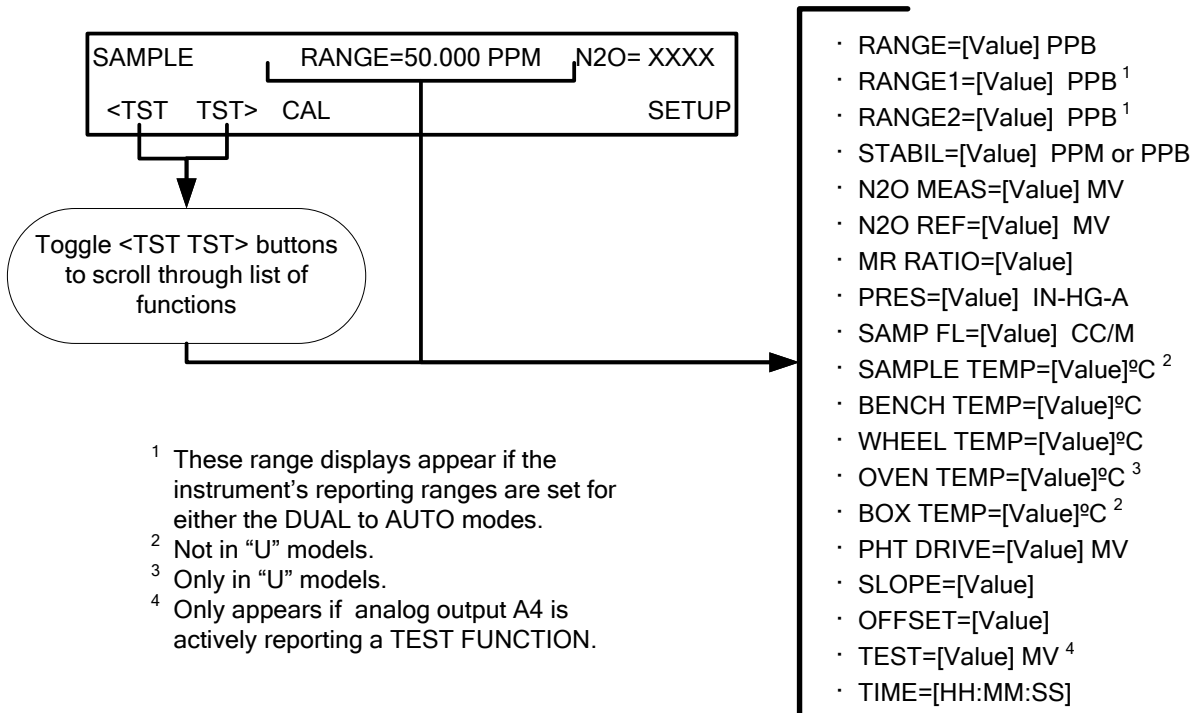

3.4. INITIAL CALIBRATION

3.4.1. CALIBRATION GASES

The information found in the Calibration Gases section of the T300/T300M Operators Manual (P/N 06864) is applicable to the T320/T320U with the following exceptions:

ZERO GAS

Zero gas is similar in chemical composition to the atmosphere that is to be measured but scrubbed of all components that might affect the analyzers readings, in this case N_2O and water vapor. For the T320/T320U this gas **MUST** be synthetic air, ultra zero air or nitrogen (N_2).

NOTE

Zero air created by a Zero Air Generator like the T-API Model T701 should not be used since the T701 does not scrub N_2O . Likewise since there are no effective and convenient catalytic, absorptive or reactive scrubbers for N_2O , T-API does not offer a zero scrubber cartridge.

SPAN GAS

Span gas is specifically mixed to match the chemical composition of the type of gas being measured at near full scale of the desired measurement range. In this case, N_2O measurements made with the T320/T320U analyzer, it is recommended that you use a span gas with a N_2O concentration equal to 80% of the measurement range for your application.

EXAMPLE: If the application is to measure between 0 ppm and 500 ppm, an appropriate span gas concentration would be 400 ppm N_2O in N_2 .

Some applications require a multipoint calibration procedure where span gases of different concentrations are applied to the analyzer under test. We recommend using a bottle of calibrated N_2O gas of higher concentration in conjunction with a gas dilution calibrator such as a Teledyne Instruments Model T700. This type of calibrator precisely mixes a high concentration gas from with zero gas (both supplied externally as either synthetic air or N_2) to accurately produce span gas of the correct concentration. Linearity profiles can be automated with this model and run unattended over night.

Currently there are no Standard Reference Material (SRM) N_2O gases available off-the-shelf from NIST (National Institute of Standards and Technology) therefore it is essential that span gas be purchased from a reputable supplier and that the gas be traceable to a reputable national standards laboratory.

3.4.2. INTERNAL PNEUMATIC FLOW

The T320 internal pneumatic flow is illustrated in Figure 3-1.

The T320U internal pneumatic flow is illustrated in Figure 3-2.

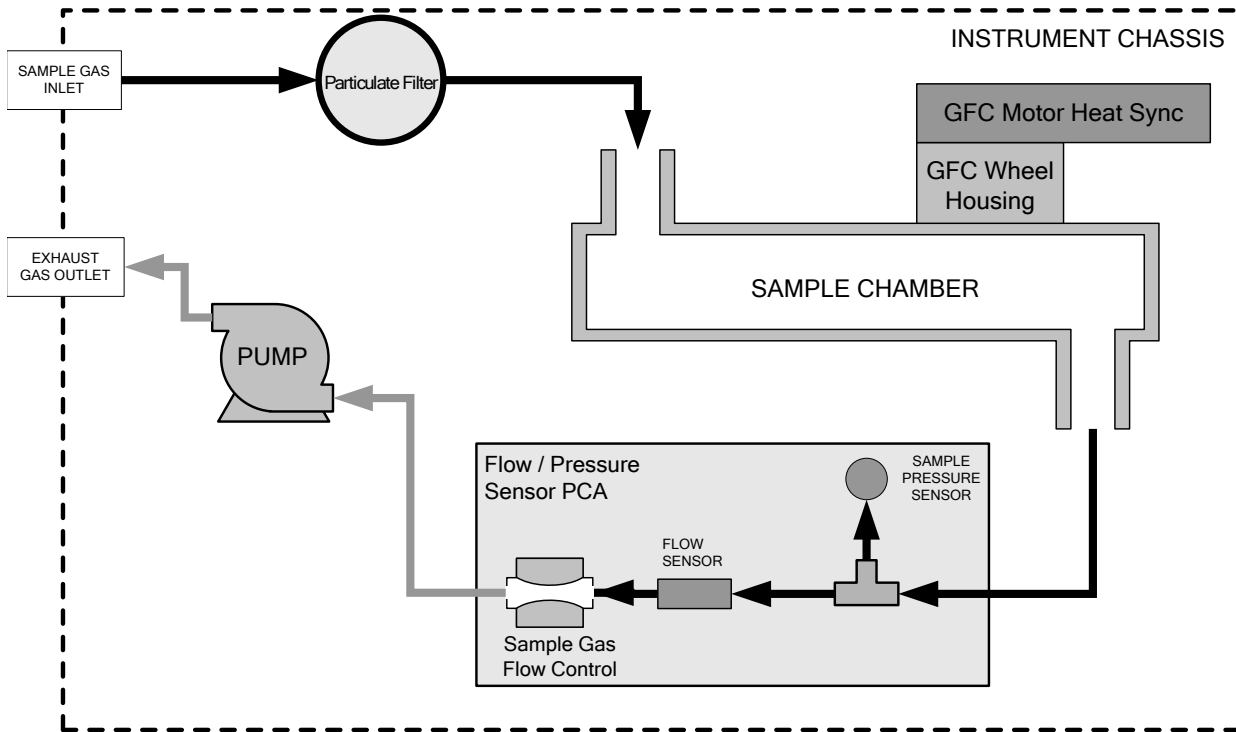

Figure 3-1. T320 Pneumatic Flow

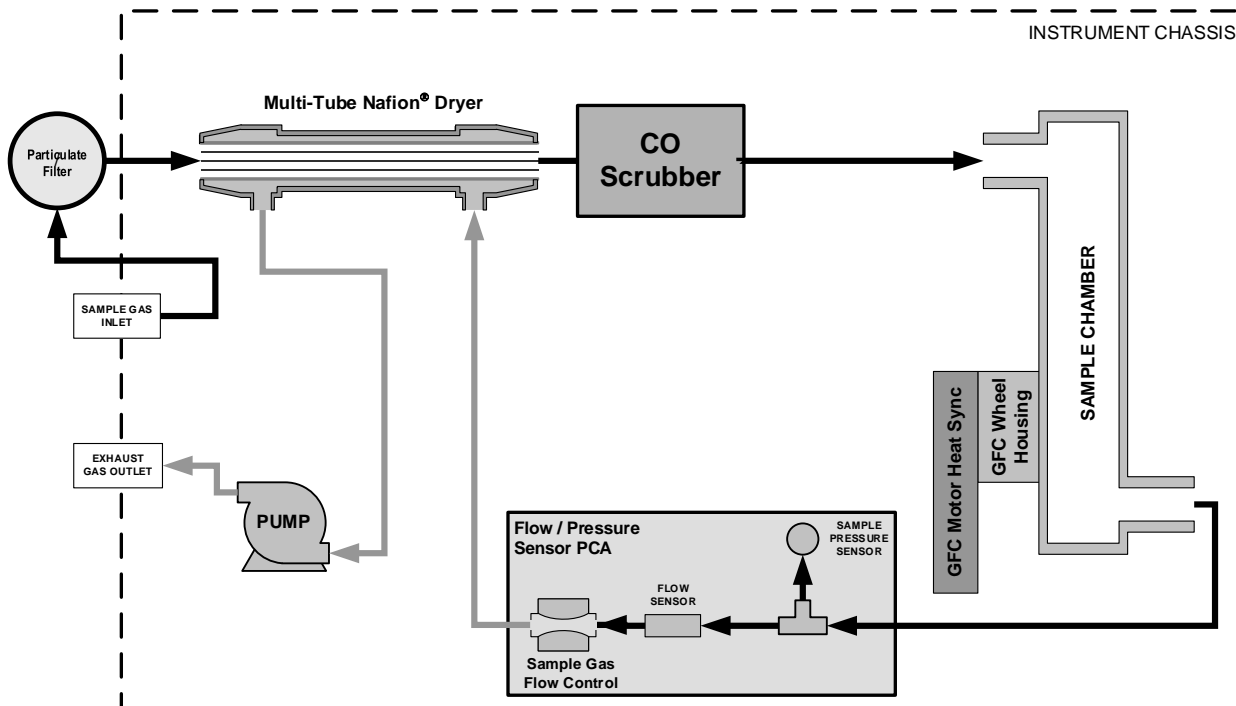

Figure 3-2. T320U Pneumatic Flow

3.4.3. PNEUMATIC CONNECTIONS TO T320/T320U BASIC CONFIGURATION:

The information found in the Pneumatic Connections section of the T300/T300M Operators Manual (P/N 06864) is applicable to the T320/T320U with the following changes:

- Synthetic air, ultra-zero air or N₂ should be used as the zero gas rather than a Zero Gas Generator like the TAPI Model 701. The following figures document this difference.

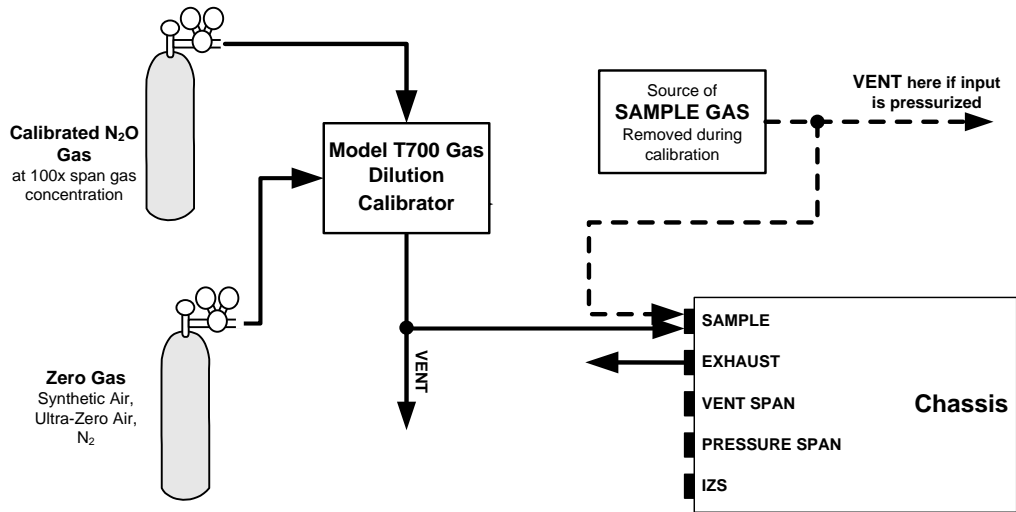

Figure 3-3. Pneumatic Connections, Basic Configuration Using Gas Dilution Calibrator

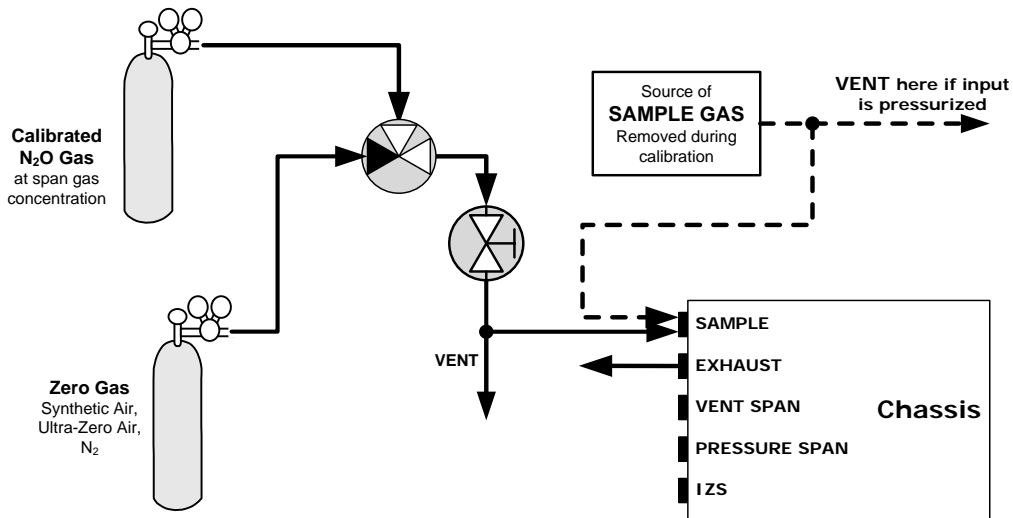

Figure 3-4. Pneumatic Connections, Basic Configuration Using Bottled Span Gas

3.4.4. PNEUMATIC CONNECTIONS TO T320/T320U WITH INTERNAL VALVE OPTIONS INSTALLED

- The following figures show the pneumatic set up for T320/T320U analyzers with one of the three available internal valve options installed. For more information on these options see Section 5 of this addendum.

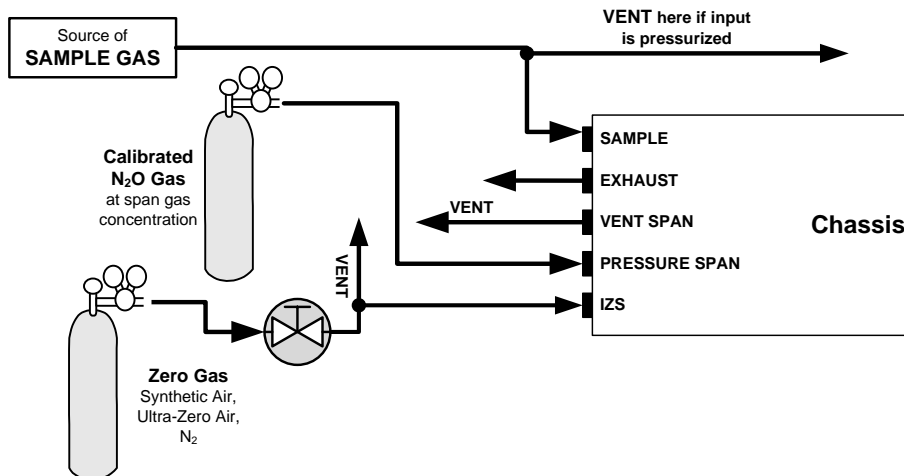

Figure 3-5. Pneumatics: Option Z/S Valve with Shutoff Valve for Pressurized Span and Atmospheric Zero

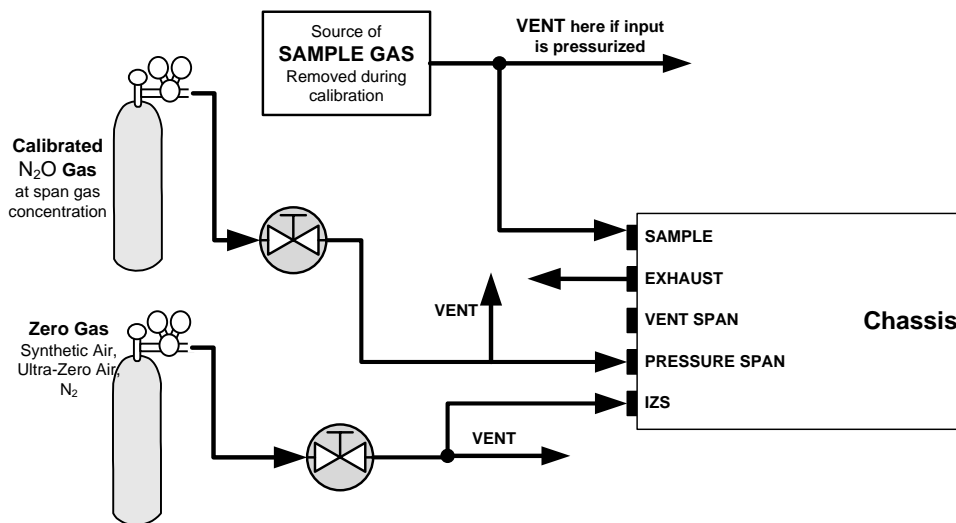

Figure 3-6. Pneumatics: Option Z/S without Shutoff Valve

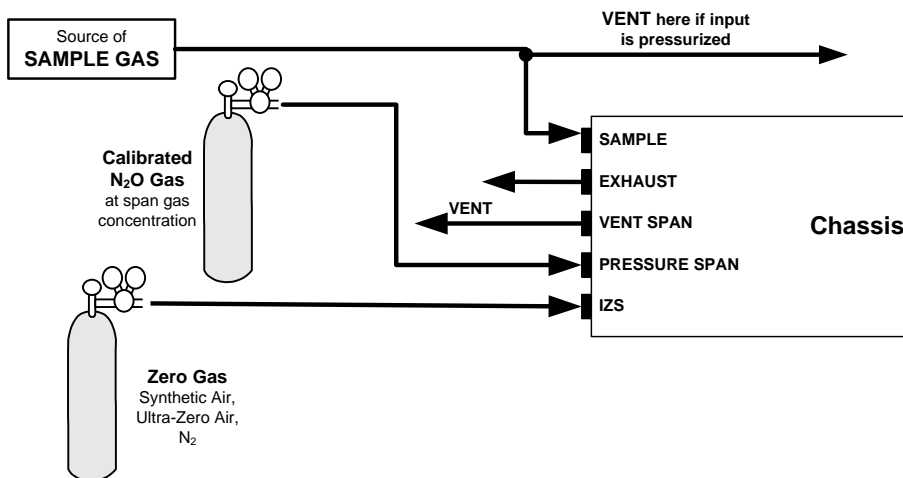

Figure 3-7. Pneumatics: Option Z/S Valve with Common Shutoff Valve for Pressurized Zero and Span

3.4.5. PNEUMATIC CONNECTIONS TO T320/T320U IN MULTIPOINT CALIBRATION APPLICATIONS

Some applications require multipoint calibration checks where Span gas of several different concentrations is needed. We recommend using high-concentration, certified, calibration gas supplied to the analyzer through a gas dilution calibrator such as a Teledyne API T700. This type of calibrator precisely mixes span gas and zero air to produce max concentration levels between 0 ppm and the concentration of the certified gas. This means that both the source of zero air and span gas must be connected to the calibrator whose output is then connected to the span inlet on the rear panel of the instrument.

4. FREQUENTLY ASKED QUESTIONS & GLOSSARY

The information found in the Frequently Asked Questions section of the T300/T300M Operators Manual (P/N 06864) is applicable to the T320/T320U.

This page intentionally left blank.

5. OPTIONAL HARDWARE AND SOFTWARE

Not all options are available for the T320 and T320U as are available for the T300 and T300M.

5.1. CALIBRATION VALVE OPTIONS FOR THE T320/T320U

There three valve options available for the T320 and T320U analyzers

Table 5-1. T320/T320U Available Valve Options

OPTION NO.	DESCRIPTION
VALVES AND IZS	
50A	Ambient Zero/Ambient Span Valves
50B	Zero / Span Valve with shut-off valve (Ambient Zero/ Pressurized Span)
50G	Zero / Span Valves with Shut-off Valve (Pressurized Zero/Pressurized Span)

For descriptions of options 50A and 50B and their use please see the Calibration Valves Options section of the T300/T300M Operators Manual (P/N 06864) but noting that wherever a zero air generator like the TAPI 701 is shown, synthetic air, ultra-zero air, or N₂ should be substituted. For a description of option 50G please see Section 5.1.1 of this addendum.

For assistance with ordering these options, please contact the Sales department of Teledyne API at:

TOLL-FREE: 800-324-5190
FAX: +1 858-657-9816
TEL: +1 858-657-9800
E-MAIL: api-sales@teledyne.com
WEB SITE: www.teledyne-api.com

5.1.1. ZERO/SPAN WITH COMMON SHUTOFF VALVES (OPTION 50G)

Option 50G is operationally and pneumatically similar to Option 50B (see T300/T300M manual), except that both the zero and span gases are applied to the analyzer under pressure. This option is designed to be used with bottled zero and span gases. A shutoff valve is used to stop flow from the bottles during sample mode and a common vent is used to bring the pressure of the calibration gas down to local ambient pressure.

Table 5-2. Zero/Span/Shutoff Valve Operating States for Option 50G

MODE	VALVE	CONDITION
SAMPLE (Normal State)	Sample/Cal	Open to SAMPLE inlet
	Zero/Span	Open to internal ZERO AIR inlet
	Shutoff Valve	Closed
ZERO CAL	Sample/Cal	Open to ZERO/SPAN valve
	Zero/Span	Open to ZERO AIR inlet
	Shutoff Valve	Open to ZERO/SPAN valve
SPAN CAL	Sample/Cal	Open to ZERO/SPAN valve
	Zero/Span	Open to SPAN inlet
	Shutoff Valve	Open to ZERO/SPAN valve

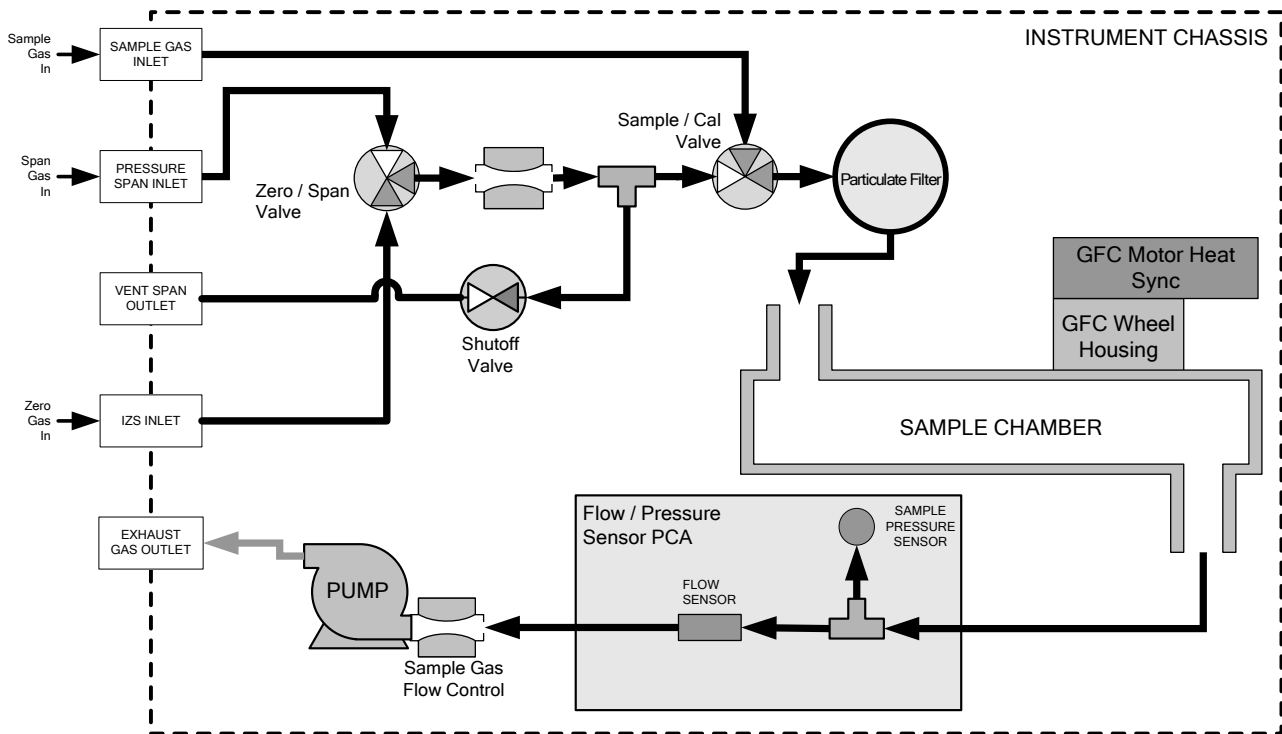

Figure 5-1. Internal Pneumatic Flow, Option Zero/Span with Common Shutoff Valves

6. BASIC OPERATION

6.1. TEST FUNCTIONS

The information found in the Test Functions section of the T300/T300M Operators Manual (P/N 06864) is applicable to the T320/T320U with the following exception(s):

- The following table supersedes Test Functions Defined table of the T300/T300M Operators Manual (P/N 06864).

Table 6-1. Test Functions Defined

Parameter	Display Title	Units	Meaning
RANGE -- RANGE1 RANGE2	RANGE	PPB, PPM UGM, MGM	The full-scale limit at which the output range of the analyzer's Analog Outputs is currently set. <ul style="list-style-type: none"> THIS IS NOT the Physical Range of the instrument. See Section 6.6.1 of the T300/T300M Operators Manual (P/N 06864) for more information. If DUAL or AUTO Range modes have been selected, two RANGE functions will appear, one for each range.
Stability	STABIL	PPB, PPM UGM, MGM	Standard deviation of N ₂ O concentration readings. Data points are recorded every ten seconds using the last 25 data points.
N ₂ O Measure	MEAS	MV	The demodulated, peak IR detector output during the measure portion of the GFC Wheel cycle.
N ₂ O Reference	REF	MV	The demodulated, peak IR detector output during the reference portion of the GFC wheel cycle.
Measurement / Reference Ratio	MR Ratio	–	The result of N2O MEAS divided by N2O REF based on readings taken during the normal sample measurement portion of the A-REF cycle. This ratio is the primary value used to compute N ₂ O concentration. The value displayed is not linearized.
Sample Pressure	PRES	In-Hg-A	The absolute pressure of the Sample gas as measured by a pressure sensor located inside the sample chamber.
Sample Flow	SAMPLE FL	cm ³ /min	Sample mass flow rate as measured by the flow rate sensor in the sample gas stream,
Bench Temperature	BENCH TEMP	°C	Optical bench temperature.
Wheel Temperature	WHEEL TEMP	°C	GFC wheel temperature.
Box Temperature	BOX TEMP	°C	The temperature inside the analyzer chassis.
Photo-detector Temp. Control Voltage	PHT DRIVE	mV	The drive voltage being supplied to the thermoelectric coolers of the IR photo-detector by the sync/demod Board.
Slope	SLOPE	–	The sensitivity of the instrument as calculated during the last calibration activity. The SLOPE parameter is used to set the span calibration point of the analyzer.
Offset	OFFSET	–	The overall offset of the instrument as calculated during the last calibration activity. The OFFSET parameter is used to set the zero point of the analyzer response.
Test Channel Output	TEST	mV	The raw voltage being output on the analyzer's A4 analog output. Only appears when the test channel is assigned a function.
Current Time	TIME	–	The current time. This is used to create a time stamp on DAS readings, and by the AUTOCAL feature to trigger calibration events.

NOTE

Upper span limit setting for the individual range modes are shared. Resetting the span limit in one mode also resets the span limit for the corresponding range in the other modes as follows:

NOTE

Concentrations displayed in mg/m³ and ug/m³ use 0°C , 760 mmHg for Standard Temperature and Pressure (STP). Consult your local regulations for the STP used by your agency.

NOTE

Once the units of measurement have been changed, the unit **MUST** be recalibrated, as the “expected span values” previously in effect will no longer be valid. Simply entering new expected span values without running the entire calibration routine is not sufficient.

The following equations give approximate conversions between volume/volume units and weight/volume units:

$$\text{N}_2\text{O ppb} \times 2.052 = \text{N}_2\text{O ug/m}^3$$

$$\text{N}_2\text{O ppm} \times 2.052 = \text{N}_2\text{O mg/m}^3$$

6.1.1. SELECTING A TEST CHANNEL FUNCTION FOR OUTPUT A4

This section supplements the corresponding section of the T300/T300M Operators Manual (P/N 06864)

The Test Functions available to be reported on analog output **A4** are:

Table 6-2. Test Channels Functions Available on the T320/T320U's Analog Output

TEST CHANNEL	DESCRIPTION	ZERO	FULL SCALE
NONE	TEST CHANNEL IS TURNED OFF		
N2O MEAS	The raw output of the optical bench's IR detector during the measure phase of the m/r cycle	0 mV	5000 mV
N2O REF	The raw output of the optical bench's IR detector during the reference phase of the m/r cycle	0 mV	5000 mV
SAMPLE PRESSURE	The pressure of gas in the optical bench's sample chamber	0" Hg	40" Hg-In-A
SAMPLE FLOW	The gas flow rate through the optical bench's sample chamber	0 cm ³ /min	1000 cm ³ /min
BENCH TEMP	The temperature of optical bench's itself	0 C°	70 C°
WHEEL TEMP	The temperature of GFC wheel	0 C°	70 C°
BOX TEMP	The temperature of the circulating air inside the convection oven section of the T320/T320U's interior.	0 C°	70 C°
PHT DRIVE	The drive voltage being supplied to the thermoelectric coolers of the IR photo-detector by the sync/demod Board.	0 mV	5000 mV

Once a function is selected, the instrument not only begins to output a signal on the analog output, but also adds **TEST** to the list of Test Functions viewable via the Front Panel Display.

7. ADVANCED FEATURES

The information found in the Advanced Features section of the T300/T300M Operators Manual (P/N 06864) is applicable to the T320 and T320U we recommend that you read that section before continuing.

This page intentionally left blank.

8. REMOTE OPERATION

The information found in the Remote Operation section of the T300/T300M Operators Manual (P/N 06864) is applicable to the T320 and T320U we recommend that you read that section before continuing.

8.1.1. HESSEN PROTOCOL

The information found in the Hessen Protocol Gas ID section of the T300/T300M Operators Manual (P/N 06864) is applicable to the T320/T320U with the following exception(s):

- There is only one default gas type programmed into the T320/T320U: the Hessen Gas ID for N₂O is 320.

This page intentionally left blank.

9. CALIBRATION PROCEDURES

Calibration of the T320/T320U should be performed according to the procedures described in the Calibration section of the T300/T300M Manual - P/N 06864 with the following notes and exceptions:

- Delivering span and zero gases for the higher resolution the T320/T320U can be difficult. Attention must be paid to the quality of the gases, the level of contaminants in the gases as well as the history and conditioning of the gas delivery components.
- The analyzer must be continually operating with an adequate flow of sample gas, for 2 hours prior to performing a calibration (12 hours is recommended for the initial calibration).
 - DO NOT calibrate the analyzer if it has been turned off or if no sample gas has been flow through it within the last 2 hours.
- After this stabilization period is complete and just prior to performing the initial calibration, force the instrument to perform an auto-reference measurement.

REQUIRED EQUIPMENT, SUPPLIES AND EXPENDABLES

- Gas lines to and from the analyzer should be PTFE or FEP Teflon, glass, or stainless steel only.
- Zero-air source which must be synthetic air, ultra-zero air or nitrogen (N₂). A zero air generator like a T-API M701 should not be used.
- Span gas source (defined in the Calibration section's Span Gas subsection of the T300/T300M Operators Manual; but use N₂O instead of CO).
- A recording device such as a strip-chart recorder and/or data logger (optional). Data recording device should be capable of bi-polar operation so that negative readings can be recorded.
- For electronic documentation, the internal data acquisition system can be used.

NOTE

If any problems occur while performing the following calibration procedures, refer to Troubleshooting and Service section of the T300/T300M manual for troubleshooting tips.

MANUAL CALIBRATION

The information found in the Manual Calibration section of the T300/T300M Operators Manual (P/N 06864) is applicable to the T320/T320U with the following exception:

- Set the display to show the **N2OSTB** test rather than the **CO STB** test function mentioned in the T300/T300M operator's manual.

This page intentionally left blank.

10. EPA PROTOCOL CALIBRATION

The information found in the EPA Protocol Calibration section of the T300/T300M Operators Manual (P/N 06864) does not apply to the T320/T320U as there are no USEPA reference methods for the measurement of N₂O.

This page intentionally left blank.

11. PRINCIPLES OF OPERATION

The information found in the Principles of Operation section of the T300/T300M Operators Manual (P/N 06864) is applicable to the T320 and T320U (we recommend that you read this section before continuing) with the following exception:

The wavelength of operation is 4.58 μ m versus 4.7 μ m for the T300/T300M.

This page intentionally left blank.

12. MAINTENANCE SCHEDULE

The information found in the Maintenance section of the T300/T300M Operators Manual (P/N 06864) is applicable to the T320/T320U with the following exception(s):

- Since a catalytic zero scrubber is not available for the T320 or T320U there is no replacement schedule for the scrubber material.
- The Test record below should be used in place of the one included with the T300/T300M manual.

Table 12-1. T320/T320U Test Function Record

FUNCTION	OPERATING MODE	DATE RECORDED					
STABILITY	ZERO CAL						
N2O MEAS	ZERO CAL						
N2O REF	ZERO CAL						
MR RATIO	ZERO CAL						
	SPAN CAL						
PRES	SAMPLE						
PHT DRIVE	SAMPLE AFTER WARM-UP						
SLOPE	SPAN CAL						
OFFSET	ZERO CAL						
BOX TEMP	SAMPLE						

This page intentionally left blank.

13. TROUBLESHOOTING & SERVICE

The information found in the Troubleshooting and Service section of the T300/T300M Operators Manual (P/N 06864) is applicable to the T320 and T320U. It is recommended that you read that section before continuing.

This page intentionally left blank.