



USER MANUAL

MODEL T803 ***CO₂/O₂ ANALYZER***

© TELEDYNE API
9970 CARROLL CANYON ROAD
SAN DIEGO, CA 92131-1106
USA

Toll-free Phone: 800-324-5190
Phone: +1 858-657-9800
Fax: +1 858-657-9816
Email: api-sales@teledyne.com
Website: <http://www.teledyne-api.com/>

NOTICE OF COPYRIGHT

© 2011-2016 Teledyne Advanced Pollution Instrumentation. All rights reserved.

TRADEMARKS

All trademarks, registered trademarks, brand names or product names appearing in this document are the property of their respective owners and are used herein for identification purposes only.

This page intentionally left blank.

SAFETY MESSAGES

Important safety messages are provided throughout this manual for the purpose of avoiding personal injury or instrument damage. Please read these messages carefully. Each safety message is associated with a safety alert symbol, and are placed throughout this manual; the safety symbols are also located inside the instrument. It is imperative that you pay close attention to these messages, the descriptions of which are as follows:



WARNING: Electrical Shock Hazard



HAZARD: Strong oxidizer



GENERAL WARNING/CAUTION: Read the accompanying message for specific information.



CAUTION: Hot Surface Warning



Do Not Touch: Touching some parts of the instrument without protection or proper tools could result in damage to the part(s) and/or the instrument.



Technician Symbol: All operations marked with this symbol are to be performed by qualified maintenance personnel only.



Electrical Ground: This symbol inside the instrument marks the central safety grounding point for the instrument.



CAUTION

This instrument should only be used for the purpose and in the manner described in this manual. If you use this instrument in a manner other than that for which it was intended, unpredictable behavior could ensue with possible hazardous consequences.

NEVER use any gas analyzer to sample combustible gas(es)!

Note

For Technical Assistance regarding the use and maintenance of this instrument or any other Teledyne API product, contact Teledyne API's Technical Support Department:

Telephone: 800-324-5190

Email: sda_techsupport@teledyne.com

or access any of the service options on our website at <http://www.teledyne-api.com/>

CONSIGNES DE SÉCURITÉ

Des consignes de sécurité importantes sont fournies tout au long du présent manuel dans le but d'éviter des blessures corporelles ou d'endommager les instruments. Veuillez lire attentivement ces consignes. Chaque consigne de sécurité est représentée par un pictogramme d'alerte de sécurité; ces pictogrammes se retrouvent dans ce manuel et à l'intérieur des instruments. Les symboles correspondent aux consignes suivantes :



AVERTISSEMENT : Risque de choc électrique



DANGER : Oxydant puissant



AVERTISSEMENT GÉNÉRAL / MISE EN GARDE : Lire la consigne complémentaire pour des renseignements spécifiques



MISE EN GARDE : Surface chaude



Ne pas toucher : Toucher à certaines parties de l'instrument sans protection ou sans les outils appropriés pourrait entraîner des dommages aux pièces ou à l'instrument.



Pictogramme « technicien » : Toutes les opérations portant ce symbole doivent être effectuées uniquement par du personnel de maintenance qualifié.



Mise à la terre : Ce symbole à l'intérieur de l'instrument détermine le point central de la mise à la terre sécuritaire de l'instrument.

MISE EN GARDE



Cet instrument doit être utilisé aux fins décrites et de la manière décrite dans ce manuel. Si vous utilisez cet instrument d'une autre manière que celle pour laquelle il a été prévu, l'instrument pourrait se comporter de façon imprévisible et entraîner des conséquences dangereuses.

NE JAMAIS utiliser un analyseur de gaz pour échantillonner des gaz combustibles!

WARRANTY

WARRANTY POLICY (02024J)

Teledyne Advanced Pollution Instrumentation (TAPI), a business unit of Teledyne Instruments, Inc., provides that:

Prior to shipment, TAPI equipment is thoroughly inspected and tested. Should equipment failure occur, TAPI assures its customers that prompt service and support will be available. (For the instrument-specific warranty period, please refer to the “Limited Warranty” section in the Terms and Conditions of Sale on our website at the following link: http://www.teledyne-api.com/terms_and_conditions.asp).

COVERAGE

After the warranty period and throughout the equipment lifetime, TAPI stands ready to provide on-site or in-plant service at reasonable rates similar to those of other manufacturers in the industry. All maintenance and the first level of field troubleshooting are to be performed by the customer.

NON-TAPI MANUFACTURED EQUIPMENT

Equipment provided but not manufactured by TAPI is warranted and will be repaired to the extent and according to the current terms and conditions of the respective equipment manufacturer’s warranty.

PRODUCT RETURN

All units or components returned to Teledyne API should be properly packed for handling and returned freight prepaid to the nearest designated Service Center. After the repair, the equipment will be returned, freight prepaid.

The complete Terms and Conditions of Sale can be reviewed at http://www.teledyne-api.com/terms_and_conditions.asp



CAUTION – Avoid Warranty Invalidation

Failure to comply with proper anti-Electro-Static Discharge (ESD) handling and packing instructions and Return Merchandise Authorization (RMA) procedures when returning parts for repair or calibration may void your warranty. For anti-ESD handling and packing instructions, please refer to the manual, Fundamentals of ESD, PN 04786, in its “Packing Components for Return to Teledyne API’s Customer Service” section. The manual can be downloaded from our website at <http://www.teledyne-api.com>, RMA procedures can also be found on our website.

This page intentionally left blank.

ABOUT THIS MANUAL

This T803 Operation Manual, PN 07276, is comprised of multiple documents in PDF format, as listed below.

Part No.	Rev	Name/Description
06759	C	T803 Operation Manual, top level assy
06763	C	Appendix A Menu Trees, software version A.2 (E-Series), 1.0.0 (T-Series)
07269	A	Spare Parts List (located in Appendix B of this manual)
06532	B	Warranty / Repair Form, Appendix C
06407	A	Interconnect Diagram, Appendix D

Note

We recommend that this manual be read in its entirety before any attempt is made to operate the instrument.

This page intentionally left blank.

TABLE OF CONTENTS

Safety Messages	iii
Warranty	v
About This Manual	vii
Table of Contents	9
1. INTRODUCTION, FEATURES, AND OPTIONS.....	15
1.1. T803 Overview.....	15
1.2. Features.....	15
1.3. Options	16
2. SPECIFICATIONS, APPROVALS & COMPLIANCE.....	19
2.1. Specifications.....	19
2.2. Approvals and Certifications	20
2.2.1. Safety	20
2.2.2. EMC.....	20
2.2.3. Other Type Certifications.....	20
3. GETTING STARTED.....	21
3.1. Unpacking the T803 Analyzer	21
3.1.1. Ventilation Clearance	23
3.2. Instrument Layout	23
3.2.1. Front Panel	23
3.2.2. Rear Panel.....	27
3.2.3. Internal Chassis Layout.....	29
3.3. Connections and Setup	30
3.3.1. Electrical Connections.....	30
3.3.2. Pneumatic Connections.....	44
3.4. Startup, Functional Checks, and Initial Calibration.....	48
3.4.1. Startup	48
3.4.2. Warm Up	48
3.5. Warning Messages.....	49
3.5.1. Functional Check.....	50
3.5.2. Initial Calibration.....	51
4. BASIC OPERATION.....	53
4.1. Overview of Operating Modes	53
4.2. Sample Mode.....	55
4.3. Calibration Mode.....	56
4.4. Setup MODE.....	57
5. SETUP MENU 59	
5.1. SETUP → CFG: Configuration Information	59
5.2. S ETUP → ACAL: [NOT USED]	59
5.3. SETUP → DAS: Internal Data Acquisition System	59
5.4. SETUP → RNGE: Analog Output Reporting Range Configuration.....	60
5.4.1. Physical Range versus Analog Output Reporting Ranges.....	60
5.4.2. Analog Output Ranges for CO ₂ and O ₂ Concentration	61
5.4.3. Reporting Range Modes	62
5.4.4. SETUP →RNGE → DIL: Using the Optional Dilution Ratio Feature.....	67
5.5. SETUP → PASS: Password Feature	68
5.6. SETUP → CLK: Setting the T803 Analyzer's Internal Clock.....	71
5.6.1. Setting the Internal Clock's Time and Day	71
5.6.2. Adjusting the Internal Clock's Speed.....	71
5.7. SETUP → MORE →COMM	73
5.8. SETUP → MORE → VARS: Internal Variables (VARS)	73

5.9. SETUP → MORE → DIAG: Using the Diagnostics Functions	76
5.9.1. Accessing the Diagnostic Features	77
5.10. Using the T803 Analyzer's Analog Outputs.....	78
5.10.1. Accessing the Analog Output Signal Configuration Submenu	78
5.10.2. Analog Output Voltage / Current Range Selection.....	80
5.10.3. Calibration of the Analog Outputs	81
5.10.4. Turning an Analog Output Over-Range Feature ON/OFF	90
5.10.5. Adding a Recorder Offset to an Analog Output.....	91
5.10.6. Selecting a Test Channel Function for Output A4.....	92
5.10.7. AIN Calibration	94
5.10.8. Analog Inputs (XIN1...XIN8) Option Configuration	95
5.11. SETUP →MORE → ALRM: Using the Gas Concentration Alarms (Option 61).....	96
5.11.1. Setting the T803 Option 61 Concentration Alarm Limits.....	97
6. COMMUNICATIONS SETUP AND OPERATION.....	99
6.1. Data Terminal/Communication Equipment (DTE DCE)	99
6.2. Communication Modes, Baud Rate and Port Testing	99
6.2.1. COM Port Communication Modes.....	99
6.2.2. COM Port Baud Rate.....	102
6.2.3. COM Port Testing.....	103
6.2.4. Machine ID	104
6.3. Remote Access via the Ethernet	105
6.3.1. Configuring the Ethernet using DHCP.....	105
6.3.2. Manually Configuring the Network IP Addresses.....	108
6.3.3. Changing the Analyzer's HOSTNAME	110
6.4. USB Port for Remote Access	111
6.5. Communications Protocols.....	113
6.5.1. MODBUS Setup	113
6.5.2. Hessen	114
6.5.3. Setting Hessen Protocol Status Flags.....	122
6.5.4. Instrument ID Code	124
7. DATA ACQUISITION SYSTEM (DAS & APICOM.....	125
7.1. SETUP → DAS: Using the Data Acquisition System (DAS)	125
7.1.1. DAS Status	126
7.1.2. DAS Structure.....	126
7.1.3. Default DAS Channels.....	127
7.1.4. SETUP →DAS →VIEW: Viewing DAS Channels and Individual Records.....	130
7.1.5. SETUP →DAS →EDIT: Accessing the DAS Edit Mode.....	131
7.1.6. Disabling/Enabling Data Channels.....	143
7.2. Remote DAS Configuration	144
7.2.1. DAS Configuration via APICOM.....	144
8. REMOTE OPERATION.....	147
8.1. Computer Mode	147
8.1.1. Remote Control via APICOM	147
8.2. Interactive Mode	148
8.3. Remote Access by Modem.....	152
9. CALIBRATION PROCEDURES	155
9.1. Before Calibration	156
9.1.1. Required Equipment, Supplies, and Expendables.....	156
9.1.2. Calibration Gases.....	156
9.1.3. Data Recording Devices.....	157
9.2. Manual Calibration Checks and Calibration of the T803 Analyzer	158
9.2.1. Setup for Calibration Checks and Calibration	158
9.2.2. Performing a Manual Calibration Check.....	159
9.2.3. Performing a Manual Calibration.....	159
9.3. Assessing Calibration Quality.....	162

9.4. Calibration of the T803's Electronic Subsystems	163
9.4.1. Pressure Calibration	163
9.4.2. Flow Calibration	165
10. MAINTENANCE SCHEDULE & PROCEDURES	167
10.1. Maintenance Schedule	167
10.2. Predictive Diagnostics	171
10.3. Maintenance Procedures	171
10.3.1. Replacing the Sample Particulate Filter	171
10.3.2. Rebuilding the Sample Pump	172
10.3.3. Performing Leak Checks	173
10.3.4. Performing a Sample Flow Check	174
10.3.5. Cleaning Exterior Surfaces of the T803	174
11. TROUBLESHOOTING AND SERVICE	175
11.1. General Troubleshooting	175
11.1.1. Fault Diagnosis with WARNING Messages	176
11.1.2. Fault Diagnosis with TEST Functions	179
11.1.3. DIAG → SIGNAL I/O: Using the Diagnostic Signal I/O Function	180
11.2. Using the Internal Electronic Status LEDs	182
11.2.1. CPU Status Indicator	182
11.2.2. Relay PCA Status Indicators	182
11.3. Gas Flow Problems	184
11.3.1. T803 Internal Gas Flow Diagrams	184
11.3.2. Typical Sample Gas Flow Problems	185
11.4. Calibration Problems	186
11.4.1. Miscalibrated	186
11.4.2. Non-Repeatable Zero and Span	187
11.4.3. Inability to Span – No SPAN Button	187
11.4.4. Inability to Zero – No ZERO Button	187
11.5. Other Performance Problems	187
11.5.1. Temperature Problems	188
11.6. Subsystem Checkout	188
11.6.1. AC Mains Configuration	188
11.6.2. DC Power Supply	188
11.6.3. I ² C Bus	189
11.6.4. Touchscreen Interface	190
11.6.5. LCD Display Module	190
11.6.6. Relay Board	190
11.6.7. Sensor Assembly	190
11.6.8. Pressure/Flow Sensor Assembly	191
11.6.9. Motherboard	192
11.6.10. CPU	193
11.6.11. RS-232 Communications	194
11.6.12. CO ₂ Sensor STATUS LED's	195
11.7. Repair Procedures	195
11.7.1. Repairing Sample Flow Control Assembly	195
11.7.2. Disk-On-Module Replacement Procedure	196
11.8. Frequently Asked Questions (FAQ's)	197
11.9. Technical Assistance	198
12. PRINCIPLES OF OPERATION	199
12.1. O ₂ Sensor	199
12.1.1. Magnetic Properties of O ₂ Gas	199
12.1.2. Paramagnetic Measurement of O ₂	199
12.2. CO ₂ Sensor	201
12.2.1. NDIR Measurement of CO ₂	201
12.3. Operation within the T803 Analyzer	202

12.4. Pneumatic Operation	203
12.5. Flow Rate Control	204
12.5.1. Critical Flow Orifice.....	204
12.5.2. Particulate Filter.....	205
12.5.3. Pneumatic Sensors	205
12.6. Electronic Operation	206
12.6.1. Overview.....	206
12.6.2. Central Processing Unit (CPU).....	207
12.6.3. Relay Board.....	209
12.6.4. Heater Control	211
12.6.5. Motherboard	211
12.6.6. I ² C Data Bus	213
12.6.7. Power Supply / Circuit Breaker	213
12.6.8. Front Panel Touchscreen/Display Interface	215
12.6.9. Software Operation.....	216
12.6.10. Adaptive Filter.....	216
12.6.11. Calibration - Slope and Offset	217
12.6.12. Temperature and Pressure Compensation	217
12.6.13. Internal Data Acquisition System (DAS)	217
Glossary.....	219
INDEX.....	223

LIST OF FIGURES

Figure 3-1:	Front Panel Layout	23
Figure 3-2:	Display Screen and Touch Control.....	24
Figure 3-3:	Display/Touch Control Screen Mapped to Menu Charts.....	26
Figure 3-4:	Rear Panel Layout.....	27
Figure 3-5:	Internal Layout.....	29
Figure 3-6:	Analog In Connector.....	31
Figure 3-7:	Analog Output Connector	32
Figure 3-8:	Current Loop Option Installed	33
Figure 3-9:	Status Output Connector.....	35
Figure 3-10:	Control Input Connector	36
Figure 3-11:	Concentration Alarm Relay	37
Figure 3-12:	Default Pin Assignments, Rear Panel COM Port Connectors	39
Figure 3-13:	CPU Connector Pin-Outs for RS-232 Mode.....	40
Figure 3-14:	Jumper and Cables for Multidrop Mode	42
Figure 3-15:	RS-232-Multidrop PCA Host/Analyzer Interconnect Diagram.....	43
Figure 3-16:	Pneumatic Connections, Using Bottled Span Gas.....	46
Figure 3-17:	T803 Internal Gas Flow	47
Figure 3-18:	Viewing and Clearing T803 WARNING Messages	50
Figure 4-1:	Front Panel Display	54
Figure 4-2:	Viewing T803 Test Functions	55
Figure 5-1:	Analog Output Connector Pin Out.....	61
Figure 5-2:	Setup for Checking / Calibrating DCV Analog Output Signal Levels	85
Figure 5-3:	Setup for Checking / Calibration Current Output Signal Levels Using an Ammeter	87
Figure 5-4:	Alternative Setup Using 250Ω Resistor for Checking Current Output Signal Levels	89
Figure 7-1:	Default DAS Channel Setup.....	129
Figure 7-2:	APICOM Remote Control Program Interface.....	144
Figure 7-3:	APICOM User Interface for Configuring the DAS	145
Figure 9-1:	Pneumatic Connections Using Bottled Span Gas.....	158
Figure 10-1:	Sample Particulate Filter Assembly.....	172
Figure 11-1:	Viewing and Clearing Warning Messages	178
Figure 11-2:	Example of Signal I/O Function	181

Figure 11-3:	CPU Status Indicator	182
Figure 11-4:	Relay PCA Status LEDs Used for Troubleshooting	183
Figure 11-5:	T803 – Internal Gas Flow	184
Figure 11-6:	Location of Diagnostic LEDs on CO ₂ Sensor PCA	195
Figure 11-7:	Critical Flow Restrictor Assembly / Disassembly	196
Figure 12-1:	Paramagnetic O ₂ Sensor Design	200
Figure 12-2:	Paramagnetic O ₂ Sensor Block Diagram	200
Figure 12-3:	CO ₂ Sensor Theory of Operation	201
Figure 12-4:	CO ₂ Sensor PCA Layout and Electronic Connections	202
Figure 12-5:	Internal Pneumatic Flow	203
Figure 12-6:	Flow Control Assembly & Critical Flow Orifice	205
Figure 12-7:	T803 Electronic Block Diagram	207
Figure 12-9:	Relay PCA Layout (PN 04135).....	209
Figure 12-10:	Relay PCA with AC Relay Retainer in Place.....	210
Figure 12-11:	Status LED Locations – Relay PCA	211
Figure 12-12:	Power Distribution Block Diagram.....	214
Figure 12-13:	Front Panel and Display Interface Block Diagram	215
Figure 12-14:	Basic Software Operation.....	216

LIST OF TABLES

Table 1-1:	Analyzer Options	16
Table 2-1:	T803 Specifications	19
Table 3-1:	Ventilation Clearance	23
Table 3-2:	Display Screen and Touch Control Description	25
Table 3-3:	Rear Panel Component Descriptions	28
Table 3-4:	Analog Input Pin Assignments	31
Table 3-5:	Analog Output Pin-Outs	32
Table 3-6:	Status Output Signals.....	35
Table 3-7:	Control Input Signals	36
Table 3-8:	Front Panel Display during System Warm-Up	48
Table 3-9:	Warning Messages.....	49
Table 4-1:	Analyzer Operating Modes	54
Table 4-2:	Test Functions Defined	56
Table 6-4:	Primary Setup Mode Features and Functions.....	57
Table 6-5:	Secondary Setup Mode Features and Functions.....	58
Table 5-6:	Password Levels	69
Table 5-1:	Variable Names (VARS).....	74
Table 5-2:	Diagnostic Mode (DIAG) Functions.....	76
Table 5-3:	DIAG - Analog I/O Functions.....	78
Table 5-4:	Analog Output Voltage Range Min/Max	80
Table 5-5:	Voltage Tolerances for the TEST CHANNEL Calibration	85
Table 5-6:	Current Loop Output Check	89
Table 5-7:	Test Channels Functions available on the T803's Analog Output	92
Table 5-8:	Concentration Alarm Default Settings	96
Table 6-1:	COM Port Communication Modes.....	100
Table 6-2:	Ethernet Status Indicators	105
Table 6-3:	LAN/Internet Configuration Properties	106
Table 6-4:	RS-232 Communication Parameters for Hessen Protocol.....	115
Table 6-5:	Teledyne API Hessen Protocol Response Modes	118
Table 6-6:	Default Hessen Status Flag Assignments.....	122
Table 7-1:	SAMPLE LED Status Indicators for DAS	126
Table 7-2:	DAS Data Channel Properties.....	127

Table 7-3:	DAS Data Parameter Functions	134
Table 8-1:	Terminal Mode Software Commands.....	148
Table 8-2:	Teledyne API Serial I/O Command Types	149
Table 9-1:	NIST SRM's Available for Traceability of O ₂ Calibration Gases.....	157
Table 9-2:	Calibration Data Quality Evaluation.....	162
Table 10-1:	T803 Maintenance Schedule.....	169
Table 10-2:	T803 Test Function Record.....	170
Table 10-3:	Predictive uses for Test Functions	171
Table 11-1:	Warning Messages - Indicated Failures	178
Table 11-2:	Test Functions - Indicated Failures	180
Table 11-3:	Relay PCA Watchdog LED Failure Indications	182
Table 11-4:	Relay PCA Status LED Failure Indications	183
Table 11-5:	DC Power Test Point and Wiring Color Codes	189
Table 11-6:	DC Power Supply Acceptable Levels.....	189
Table 11-7:	Analog Output Test Function - Nominal Values Current Outputs	192
Table 11-8:	Status Outputs Check	193
Table 12-1:	Relay PCA Status LEDs	210

LIST OF APPENDICES

APPENDIX A - VERSION SPECIFIC SOFTWARE DOCUMENTATION v. A.4 (E-Series); 1.0.3 (T-Series)

- A-1 - Software Menu Trees
- A-2 - Setup Variables for Serial I/O
- A-3 - Warnings and Test Functions
- A-4 - Signal I/O Definitions
- A-5 - DAS Functions
- A-6 - Terminal Command Designators
- A-7 - MODBUS[®] Register Map

APPENDIX B – Spare Parts List

APPENDIX C – Repair Questionnaire

APPENDIX D – Interconnect Diagram

1. INTRODUCTION, FEATURES, AND OPTIONS

1.1. T803 OVERVIEW

The Model T803 Carbon Dioxide/Oxygen Analyzer (T803 CO₂/O₂ Analyzer) is a microprocessor-controlled analyzer that determines the concentration of molecular carbon dioxide (CO₂) and oxygen (O₂) in the sample gas drawn through the instrument. It uses infrared absorption to measure CO₂ concentration and paramagnetic technology to measure O₂ concentration.

The Model T803 analyzer's multi-tasking software gives the ability to track and report a large number of operational parameters in real time. These readings are compared to diagnostic limits kept in the analyzer's memory where, should any fall outside of those limits, the analyzer issues automatic warnings.

Built-in data acquisition capability using the analyzer's internal memory, allows the logging of multiple parameters including averaged or instantaneous concentration values, calibration data, and operating parameters such as pressure and flow rate. Stored data are easily retrieved through the serial port or Ethernet port via our APICOM software or from the front panel, allowing operators to perform predictive diagnostics and enhanced data analysis by tracking parameter trends. Multiple averaging periods of one minute to 365 days are available for over a period of one year.

1.2. FEATURES

Some of the exceptional features of your T803 CO₂ / O₂ Analyzer are:

- Non-depleting, CO₂/O₂ measurement technologies:
 - Virtually no cross-sensitivities
 - Rapid response times
 - No consumable parts
 - Consistent performance over time
- Microprocessor controlled for versatility
- LCD Graphical User Interface with capacitive touch screen
- Multi-tasking software for viewing of test variables during operation
- Continuous self-checking with alarms
- Bi-directional USB, RS-232, and 10/100Base-T Ethernet (optional USB and RS-485) ports for remote operation
- Front panel USB ports for peripheral devices
- Digital status outputs to indicate instrument operating condition
- Adaptive signal filtering to optimize response time
- Internal data logging with 1 min to 365-day multiple average
- Remote operation when used with Teledyne API's APICOM software
- Temperature and Pressure Compensation
- Ranges, 0-1% to 0-100.0%, user adjustable



HAZARD
OXYGEN IS A STRONG OXIDIZER.

This is a general purpose instrument designed for usage in nonhazardous areas. Ensure that all safety precautions related combustible gases are followed.

Before working with the casing open, be sure to turn off power to the analyzer, and perform air or N₂ gas purging of not only the analyzer inside, but also the sample gas line.

In addition, carefully prevent oil and grease from adhering to any tubing. Otherwise, poisoning, fire or explosion may be caused due to gas leakage, etc.

1.3. OPTIONS

Table 1-1 presents the options available with this analyzer. For assistance with ordering, please contact the Sales department of Teledyne API at:

PHONE (toll free, North America)	800-324-5190
FAX:	+1 858-657-9816
PHONE (Direct):	+1 858-657-9800
E-MAIL:	api-sales@teledyne.com
WEB SITE	www.teledyne-api.com

Table 1-1: Analyzer Options

Option	Option Number	Description/Notes	Reference
Pumps		Pumps meet all typical AC power supply standards while exhibiting same pneumatic performance.	
	10A	External Pump 100V - 120V @ 60 Hz	N/A
	10B	External Pump 220V - 240V @ 50 Hz	N/A
	10C	External Pump 220V - 240V @ 60 Hz	N/A
	10D	External Pump 100V – 120V @ 50 Hz	N/A
	10E	External Pump 100V @ 60 Hz	N/A
	14	Internal Pump	N/A
	13	High Voltage Internal Pump 240V @ 50Hz	N/A
Rack Mount Kits		Options for mounting the analyzer in standard 19" racks	
	20A	Rack mount brackets with 26 in. chassis slides	N/A
	20B	Rack mount brackets with 24 in. chassis slides	N/A
	21	Rack mount brackets only (compatible with carrying strap, Option 29)	N/A
	23	Rack mount for external pump pack (no slides)	N/A

Option	Option Number	Description/Notes	Reference
Carrying Strap/Handle		Side-mounted strap for hand-carrying analyzer	
	29	Extends from “flat” position to accommodate hand for carrying. Recesses to 9mm (3/8”) dimension for storage. Can be used with rack mount brackets, Option 21. Cannot be used with rack mount slides.	N/A
	CAUTION - General Safety Hazard		
	THE T803 WEIGHS ABOUT 28 POUNDS (12.7 KG). TAKE CARE TO AVOID PERSONAL INJURY WHEN LIFTING/CARRYING THE ANALYZER.		
Analog Inputs w/USB port		Used for connecting external voltage signals from other instrumentation (such as meteorological instruments).	
	64B	Also can be used for logging these signals in the analyzer's internal DAS. (See Option 64A for USB port only).	Sections 3.3.1.2 and 5.10.8
Current Loop Analog Outputs		Adds isolated voltage-to-current conversion circuitry to the analyzer's analog outputs.	
	41	Can be configured for 0-20 mA or 4-20 mA. May be ordered separately for any of the analog outputs. Can be installed at the factory or retrofitted in the field.	Section 3.3.1.4
Parts Kits		Spare parts and expendables	
	42A	Expendables Kit for analyzer with a pump, includes a recommended set of expendables for one year of operation.	Appendix B
	42D	Expendables Kit for analyzer without a pump, includes a recommended set of expendables for one year of operation.	Appendix B
Communication Cables		For remote serial, network and Internet communication with the analyzer.	
		Type	Description
	60A	RS-232	Shielded, straight-through DB-9F to DB-25M cable, about 1.8 m long. Used to interface with older computers or code activated switches with DB-25 serial connectors.
	60B	RS-232	Shielded, straight-through DB-9F to DB-9F cable of about 1.8 m length.
	60C	Ethernet	Patch cable, 2 meters long, used for Internet and LAN communications.
	60D	USB	Cable for direct connection between instrument (rear panel USB port) and personal computer.
Concentration Alarm Relay		Issues warning when gas concentration exceeds limits set by user.	
	61	Four (4) “dry contact” relays on the rear panel of the instrument. This relay option is different from and in addition to the “Contact Closures” that come standard on all TAPI instruments.	Section 3.3.1.7
RS-232 Multidrop		Enables communications between host computer and up to eight analyzers.	
	62	Multidrop card seated on the analyzer's CPU card. Each instrument in the multidrop network requires this card and a communications cable (Option 60B).	Section 3.3.1.8

Option	Option Number	Description/Notes	Reference
USB COM Port			
	64A	Separate option if instrument not configured with Option 64B (analog inputs). Disabled when using Multidrop or RS-485 communication.	Sections 3.3.1.8 and 6.4
Special Features		Built in features, software activated	
	N/A	Maintenance Mode Switch , located inside the instrument, places the analyzer in maintenance mode where it can continue sampling, yet ignore calibration, diagnostic, and reset instrument commands. This feature is of particular use for instruments connected to Multidrop or Hessen protocol networks. Call Technical Support for activation.	N/A
	N/A	Second Language Switch activates an alternate set of display messages in a language other than the instrument's default language. Call Technical Support for a specially programmed Disk on Module containing the second language.	N/A
	N/A	Dilution Ratio Option allows the user to compensate for diluted sample gas, such as in continuous emission monitoring (CEM) where the quality of gas in a smoke stack is being tested and the sampling method used to remove the gas from the stack dilutes the gas. Call Technical Support for activation.	Section 5.4.4

2. SPECIFICATIONS, APPROVALS & COMPLIANCE

2.1. SPECIFICATIONS

Table 2-1: T803 Specifications

Parameter	Description
CO₂	
Range	0-20% Full scale (user selectable, dual ranges and auto-ranging supported)
Zero Noise ¹	<0.02% (RMS)
Span Noise ¹	< 0.1% of reading (RMS)
Lower Detectable Limit ²	<0.04%
Zero Drift	<± 0.02% (24 hours); <± 0.05% (7 days)
Span Drift (7 days)	<± 0.1%
Accuracy	<± (1.5% of range + 2% of reading)
Temperature Coefficient	<± 0.01% /°C
O₂	
Ranges	Min: 0-1% Full scale Max: 0-100% Full scale (user selectable)
Zero Noise ¹	<0.02% (RMS)
Lower Detectable Limit ²	<0.04%
Zero Drift ³	<± 0.02% (24 hours); <± 0.05% (7 days)
Span Noise ¹	< 0.05% of reading (RMS)
Span Drift (7 days)	<± 0.1%
Accuracy	<± 0.1%
Linearity	<± 0.1 %
Temperature Coefficient	<± 0.01% /°C
Rise and Fall Time	<60 seconds to 95%
Sample Flow Rate	120ml ± 20ml/min
Humidity Range	0-95% RH, Non-Condensing
Pressure Range	25-31 in•Hg
Temperature Range	5 - 40°C operating
Dimensions (HxWxD)	7" x 17" x 23.5" (178 mm x 432 mm x 597 mm)
Weight	28 lb (12.7 kg)
AC Power	100-120V 60 Hz (82W); 220-240V 50 Hz (94W)
Analog Output Ranges	0.1 V, 1 V, 5 V or 10 V (selectable) Three outputs convertible to 4-20 mA isolated current loop. All Ranges with 5% under/over-range
Recorder Offset	± 10%
Analog Output Resolution	1 part in 4096 of selected full-scale voltage

Parameter	Description
Standard I/O	1 Ethernet: 10/100Base-T 2 RS-232 (300 – 115,200 baud) 2 USB device ports 8 opto-isolated digital status outputs 6 opto-isolated digital control inputs 4 analog outputs
Optional I/O	1 USB com port 1 RS485 8 analog inputs (0-10V, 12-bit) 4 digital alarm outputs Multidrop RS232 3 4-20mA current outputs
¹ As defined by the USEPA ² Defined as twice the zero noise level by the USEPA ³ Note: zero drift is typically $\leq \pm 0.1\%$ O ₂ during the first 24 hrs of operation	

2.2. APPROVALS AND CERTIFICATIONS

The Teledyne API Model T803 Carbon Dioxide/Oxygen Analyzer was tested and certified for Safety and Electromagnetic Compatibility (EMC). This section presents the compliance statements for those requirements and directives.

2.2.1. SAFETY

IEC 61010-1:2001, Safety requirements for electrical equipment for measurement, control, and laboratory use.

CE: 2006/95/EC, Low-Voltage Directive

North American:

cNEMKO (Canada): CAN/CSA-C22.2 No. 61010-1-04
NEMKO-CCL (US): UL No. 61010-1 (2nd Edition)

2.2.2. EMC

EN 61326-1 (IEC 61326-1), Class A Emissions/Industrial Immunity

EN 55011 (CISPR 11), Group 1, Class A Emissions

FCC 47 CFR Part 15B, Class A Emissions

CE: 2004/108/EC, Electromagnetic Compatibility Directive

2.2.3. OTHER TYPE CERTIFICATIONS

For additional certifications, please contact Technical Support:

Toll-free Phone: 800-324-5190

Phone: +1 858-657-9800

Fax: +1 858-657-9816

Email: sda_techsupport@teledyne.com

3. GETTING STARTED

This section addresses the procedures for unpacking the instrument and inspecting for damage, presents clearance specifications for proper ventilation, introduces the instrument layout, then presents the procedures for getting started: making electrical and pneumatic connections, and conducting an initial calibration check.

3.1. UNPACKING THE T803 ANALYZER



**CAUTION
GENERAL SAFETY HAZARD**

To avoid personal injury, always use two persons to lift and carry the T803.



CAUTION – AVOID WARRANTY INVALIDATION

Printed circuit assemblies (PCAs) are sensitive to electro-static discharges too small to be felt by the human nervous system. Damage resulting from failure to use ESD protection when working with electronic assemblies will void the instrument warranty.

For information on preventing ESD damage, please refer to the manual, *Fundamentals of ESD, A Primer on Electro-Static Discharge*, downloadable from our website.



CAUTION!

Do not operate this instrument until removing dust plugs from **SAMPLE** and **EXHAUST** ports on the rear panel!

Note

Teledyne API recommends that you store shipping containers/materials for future use if/when the instrument should be returned to the factory for repair and/or calibration service. See Warranty section in this manual and shipping procedures on our Website at <http://www.teledyne-api.com>.

Verify that there is no apparent external shipping damage. If damage has occurred, please advise the shipper first, then Teledyne API. Keep the shipping container/packaging intact for the shipper's examination.

Included with your analyzer is a printed record of the final performance characterization performed on your instrument at the factory.

This record, *Final Test and Validation Data Sheet*, PN 068360000 is an important quality assurance and calibration record for this instrument. It should be placed in the quality records file for this instrument.

1. Carefully remove the top cover of the analyzer and check for internal shipping damage as follows:
 - a) Remove the locking screw located in the top, center of the Front panel;
 - b) Remove the two flat head, Phillips screws on the sides of the instrument (one per side towards the rear);
 - c) Slide the cover backwards until it clears the analyzer's front bezel;
 - d) Lift the cover straight up.
2. Inspect the interior of the instrument to make sure all circuit boards and other components are in good shape and properly seated.
3. Check that the connectors of the various internal wiring harnesses and pneumatic hoses are firmly and properly seated.
4. Verify that all of the optional hardware ordered with the unit has been installed. These are listed on the paperwork accompanying the analyzer.

3.1.1. VENTILATION CLEARANCE

Whether the analyzer is set up on a bench or installed into an instrument rack, be sure to leave sufficient ventilation clearance.

Table 3-1: Ventilation Clearance

AREA	MINIMUM REQUIRED CLEARANCE
Back of the instrument	4 in.
Sides of the instrument	1 in.
Above and below the instrument	1 in.

3.2. INSTRUMENT LAYOUT

Instrument layout shows front panel and display, rear panel connectors, and internal chassis layout.

3.2.1. FRONT PANEL

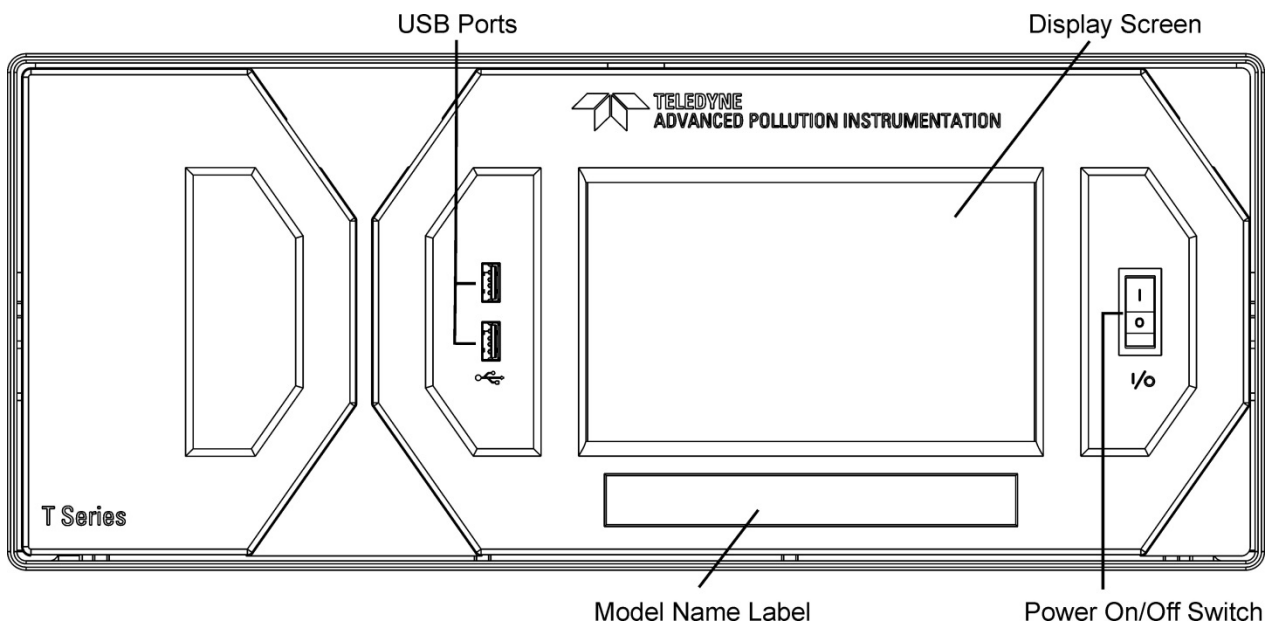

Figure 3-1: Front Panel Layout



Figure 3-2: Display Screen and Touch Control

The front panel liquid crystal display screen includes touch control. Upon analyzer start-up, the screen shows a splash screen and other initialization indicators before the main display appears, similar to Figure 3-2 above (may or may not display a Fault alarm). The LEDs on the display screen indicate the Sample, Calibration and Fault states; also on the screen is the gas concentration field (Conc), which displays real-time readouts for the primary gas and for the secondary gas if installed. The display screen also shows what mode the analyzer is currently in, as well as messages and data (Param). Along the bottom of the screen is a row of touch control buttons; only those that are currently applicable will have a label. Table 3-2 provides detailed information for each component of the screen.

ATTENTION

COULD DAMAGE INSTRUMENT AND VOID WARRANTY
Do not use hard-surfaced instruments such as pens to operate the control buttons.

Table 3-2: Display Screen and Touch Control Description

Field	Description/Function			
Status	LEDs indicating the states of Sample, Calibration and Fault, as follows:			
	Name	Color	State	Definition
	SAMPLE	Green	Off On Blinking	Unit is not operating in sample mode, DAS is disabled. Sample Mode active; Front Panel Display being updated; DAS data being stored. Unit is operating in sample mode, front panel display being updated, DAS hold-off mode is ON, DAS disabled
	CAL	Yellow	Off On Blinking	Auto Cal disabled Auto Cal enabled Unit is in calibration mode
	FAULT	Red	Off Blinking	No warnings exist Warnings exist
Conc	Displays the actual concentration of the sample gas currently being measured by the analyzer in the currently selected units of measure			
Mode	Displays the name of the analyzer's current operating mode			
Param	Displays a variety of informational messages such as warning messages, operational data, test function values and response messages during interactive tasks.			
Control Buttons	Displays dynamic, context sensitive labels on each button, which is blank when inactive until applicable.			

Figure 3-3 shows how the front panel display is mapped to the menu charts illustrated in this manual. The Mode, Param (parameters), and Conc (gas concentration) fields in the display screen are represented across the top row of each menu chart. The eight touch control buttons along the bottom of the display screen are represented in the bottom row of each menu chart.

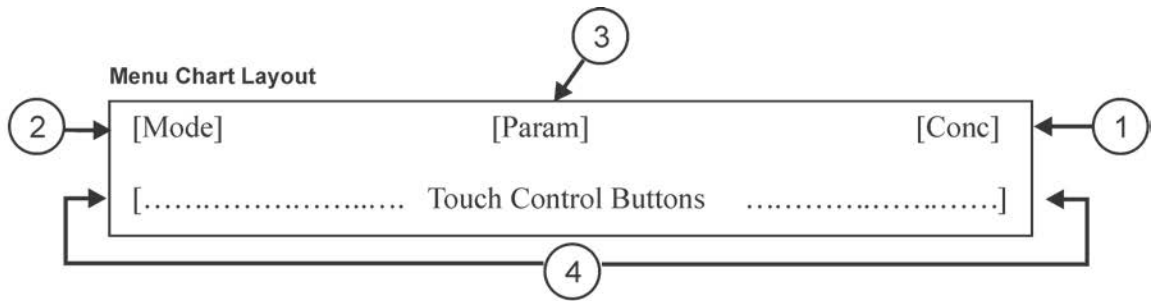

Display Example:

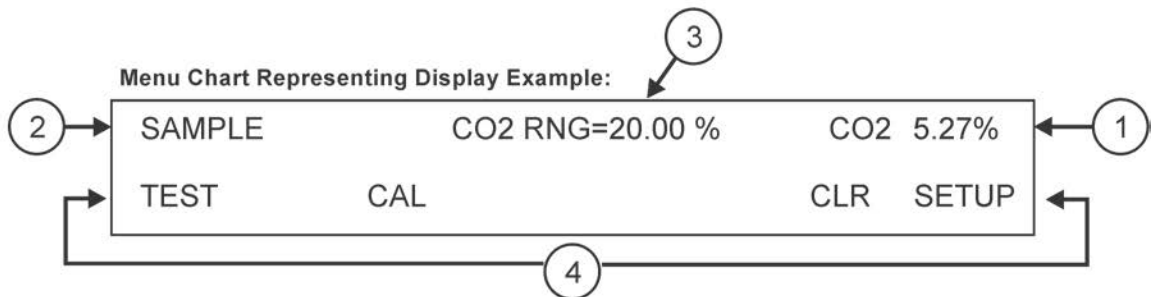

Figure 3-3: Display/Touch Control Screen Mapped to Menu Charts

3.2.2. REAR PANEL

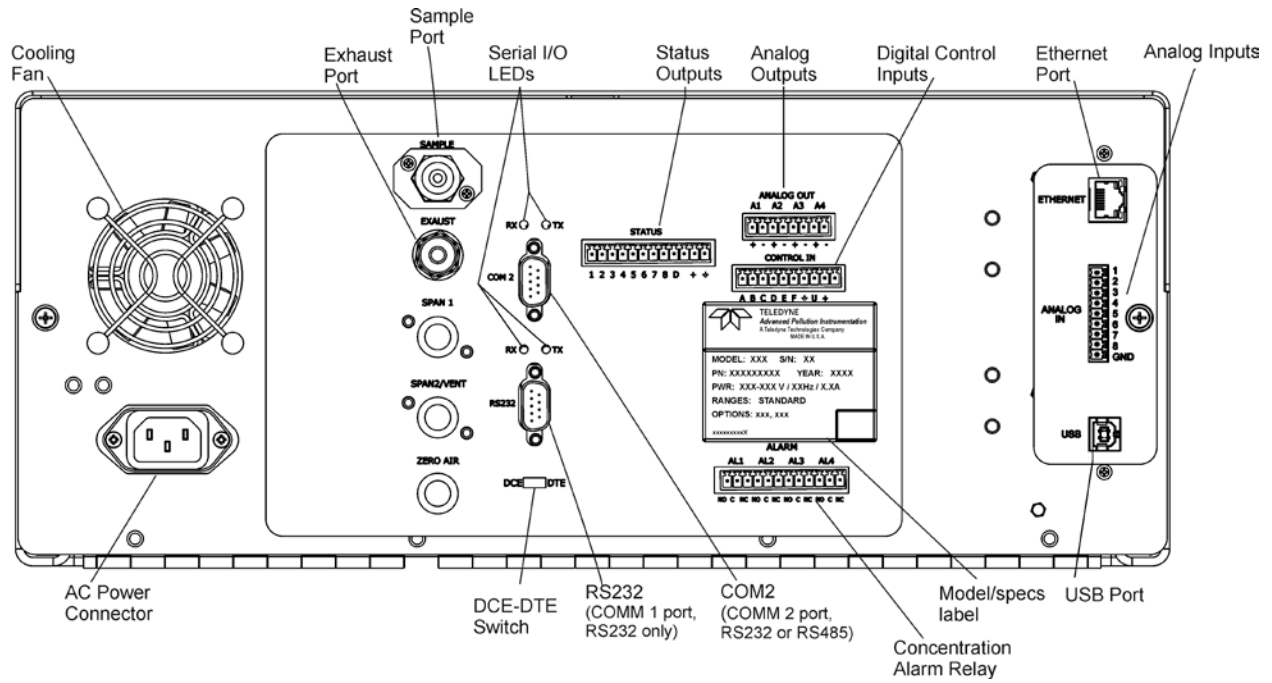



Figure 3-4: Rear Panel Layout

Table 3-3: Rear Panel Component Descriptions

Component	Function
Cooling Fan	Pulls ambient air into chassis through side vents and exhausts through rear.
 AC Power Connector	Connector for three-prong cord to apply AC power to the analyzer. CAUTION! The cord's power specifications (specs) MUST comply with the power specs on the analyzer's rear panel Model number/Volt/Freq information label
Model/specs label	Identifies analyzer's model number, and provides voltage and frequency specifications
SAMPLE	Inlet connection to be used for any one of the following: <ul style="list-style-type: none"> • Sample gas • Span gas • Calibration gas • Zero air
EXHAUST	Connect an exhaust gas line of not more than 10 meters long here that leads outside the shelter or immediate area surrounding the instrument.
SPAN 1	Not used.
SPAN2/VENT	Not used.
ZERO AIR	Not used.
RX TX	LEDs indicate receive (RX) and transmit (TX) activity on the when blinking.
COM 2	Serial communications port for RS-232 or RS-485.
RS-232	Serial communications port for RS-232 only.
DCE DTE	Switch to select either data terminal equipment or data communication equipment during RS-232 communication.
STATUS	For outputs to devices such as Programmable Logic Controllers (PLCs).
ANALOG OUT	For voltage or current loop outputs to a strip chart recorder and/or a data logger.
CONTROL IN	For remotely activating the zero and span calibration modes.
ALARM	Option for concentration alarms and system warnings.
ETHERNET	Connector for network or Internet remote communication, using Ethernet cable
ANALOG IN	Option for external voltage signals from other instrumentation and for logging these signals
USB	Connector for direct connection to personal computer, using USB cable.

3.2.3. INTERNAL CHASSIS LAYOUT

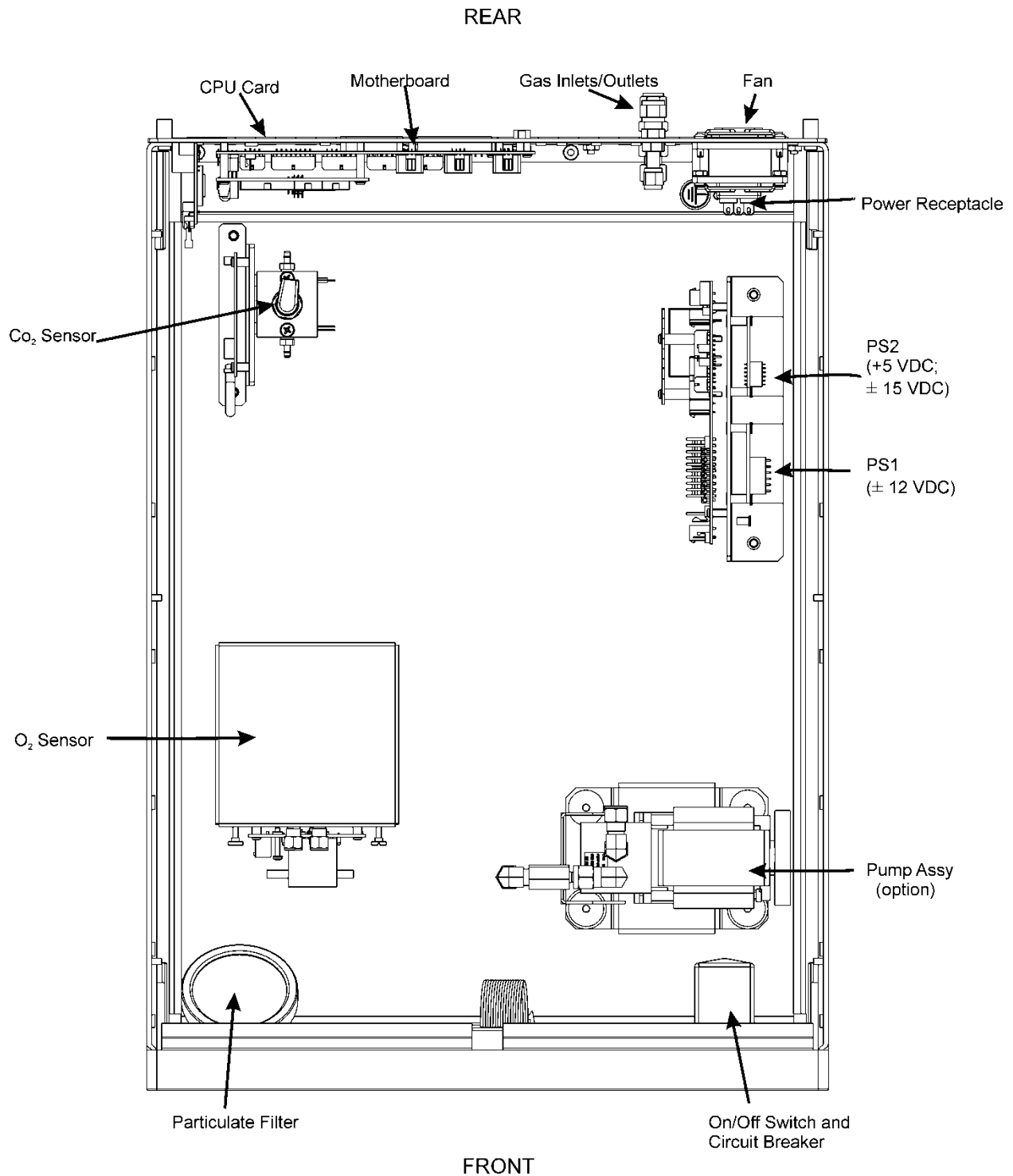

Figure 3-5: Internal Layout

3.3. CONNECTIONS AND SETUP

This section presents the electrical (Section 3.3.1) and pneumatic (Section 0) connections for setup and preparing for instrument operation.

3.3.1. ELECTRICAL CONNECTIONS



CAUTION
ELECTRICAL SHOCK HAZARD

Never disconnect PCAs, wiring harnesses or electronic subassemblies while the analyzer is under power.

Note

To maintain compliance with EMC standards, it is required that the cable length be no greater than 3 meters for all I/O connections, which include Analog In, Analog Out, Status Out, Control In, Ethernet/LAN, USB, RS-232, and RS-485.

This section presents the electrical connections for AC power and communications.

3.3.1.1. CONNECTING POWER

Attach the power cord to the analyzer and plug it into a power outlet capable of carrying at least 10 A current at your AC voltage and that it is equipped with a functioning earth ground.



CAUTION
ELECTRICAL SHOCK HAZARD

High Voltages are present inside the analyzers case.
Power connection must have functioning ground connection.
Do not defeat the ground wire on power plug.
Turn off analyzer power before disconnecting or connecting electrical subassemblies.
Do not operate with cover off.



CAUTION
GENERAL SAFETY HAZARD

The T803 analyzer can be configured for both 100-130 V and 210-240 V at either 47 or 63 Hz.

To avoid damage to your analyzer, make sure that the AC power voltage matches the voltage indicated on the Analyzer's serial number label tag (See Figure 3-4) before plugging the T803 into line power.

3.3.1.2. ANALOG INPUTS (OPTION 64) CONNECTIONS

The Analog In connector is used for connecting external voltage signals from other instrumentation (such as meteorological instruments) and for logging these signals in the analyzer's internal DAS. The input voltage range for each analog input is 0-10 VDC, and the input impedance is nominally 20k Ω in parallel with 0.1 μ F.

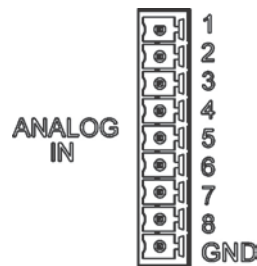

Figure 3-6: Analog In Connector

Pin assignments for the Analog In connector are presented in Table 3-4.

Table 3-4. Analog Input Pin Assignments

PIN	DESCRIPTION	DAS PARAMETER ¹
1	Analog input # 1	AIN 1
2	Analog input # 2	AIN 2
3	Analog input # 3	AIN 3
4	Analog input # 4	AIN 4
5	Analog input # 5	AIN 5
6	Analog input # 6	AIN 6
7	Analog input # 7	AIN 7
8	Analog input # 8	AIN 8
GND	Analog input Ground	N/A

¹ See Section 7.1 for details on setting up the DAS.

3.3.1.3. ANALOG OUTPUT CONNECTIONS

The T803 is equipped with several analog output channels accessible through the ANALOG OUT connector on the rear panel of the instrument. The standard configuration for these outputs is VDC. An optional current loop output is available for each (Section 3.3.1.4).

When the instrument is in its default configuration, channel A1 outputs a signal that is proportional to the CO₂ concentration of the sample gas. If Dual or Auto range is configured, channels A1 and A2 each output a signal proportional to the CO₂ concentration of the sample gas. Please refer to Section 5.4.3 for details.

Channel A3 outputs a signal proportional to the O₂ concentration of the sample gas.

Channel A4 is special. It can be set by the user (see Section 5.10.6) to output any one of the parameters accessible through the <TST TST> buttons of the unit's front panel menu.

To access these signals attach a strip chart recorder and/or data-logger to the appropriate analog output connections on the rear panel of the analyzer.

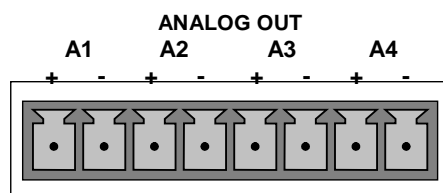

Figure 3-7: Analog Output Connector

Table 3-5: Analog Output Pin-Outs

PIN	ANALOG OUTPUT	VOLTAGE SIGNAL	CURRENT SIGNAL
1	A1	V Out	I Out +
2		Ground	I Out -
3	A2	V Out	I Out +
4		Ground	I Out -
5	A3	V Out	I Out +
6		Ground	I Out -
7	A4	V Out	NA
8		Ground	NA

3.3.1.4. CURRENT LOOP ANALOG OUTPUTS (OPTION 41) SETUP

This option adds isolated, voltage-to-current conversion circuitry to the analyzer's analog outputs. This option may be ordered separately for any of the analog outputs; it can be installed at the factory or added later. Call TELEDYNE API Sales for pricing and availability.

J19, J21, J23 Analog Output Setup:

- For **voltage** output of any one, two, or all:
 1. Jumper two leftmost pins.
 2. Jumper next two leftmost pins.
 3. Calibrate per Analog I/O Configuration menu.
- For **current** output of any one, two, or all:
 1. Remove jumper shunts.
 2. Install Current Loop option.
 3. Calibrate per Analog I/O Configuration menu.

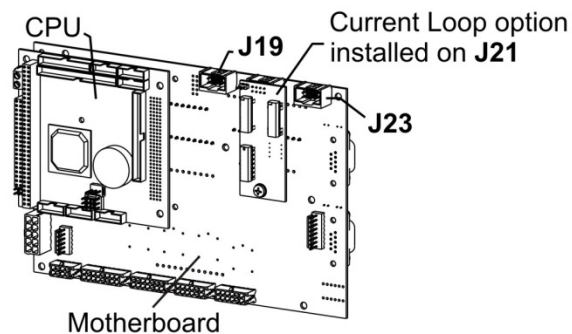
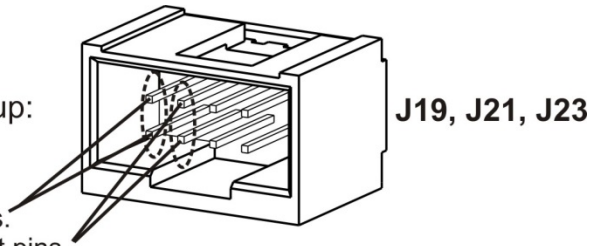

Example setup: install jumper shunts for voltage output on J19 and J23; remove jumper shunts and install Current Loop option for current output on J21.

Figure 3-8: Current Loop Option Installed

CONVERTING CURRENT LOOP ANALOG OUTPUTS TO STANDARD VOLTAGE OUTPUTS



CAUTION

Servicing or handling of circuit components requires electrostatic discharge (ESD) protection, i.e. ESD grounding straps, mats and containers. Failure to use ESD protection when working with electronic assemblies will void the instrument warranty. For more information on preventing ESD damage, please refer to the manual, *Fundamentals of ESD, A Primer on Electro-Static Discharge*, downloadable from our website.

To convert an output configured for current loop operation to the standard 0 to 5 VDC output operation:

1. Turn off power to the analyzer.
2. If a recording device was connected to the output being modified, disconnect it.

3. Remove the top cover:
 - a) Remove the set screw located at the top center of the rear panel
 - b) Remove the screws fastening the top cover to the unit (two per side).
 - c) Slide cover back.
 - d) Lift the cover straight up.
4. Remove the screw holding the current loop option to the motherboard.
5. Disconnect the current loop option PCA from the appropriate connector on the motherboard (see Figure 3-8).

Each connector, J19, J21 and J23, requires two shunts. Place one shunt on the two left most pins and the second shunt on the two pins next to it (refer to Figure 3-8 for an example).
6. Reattach the top case to the analyzer.
7. The analyzer is now ready to have a voltage-sensing, recording device attached to that output.

3.3.1.5. CONNECTING THE STATUS OUTPUTS

The status outputs report analyzer conditions via optically isolated NPN transistors, which sink up to 50 mA of DC current. These outputs can be used to interface with devices that accept logic-level digital inputs, such as programmable logic controllers (PLCs). Each status bit is an open collector output that can withstand up to 40 VDC. All of the emitters of these transistors are tied together and connected at Pin D.

Note

Most PLCs have internal provisions for limiting the current that the input will draw from an external device. When connecting to a unit that does not have this feature, an external dropping resistor must be used to limit the current through the transistor output to less than 50 mA.

At 50 mA, the transistor will drop approximately 1.2V from its collector to emitter.

The status outputs are accessed via a 12-pin connector on the analyzer's rear panel labeled STATUS (see Figure 3-4). Pin-outs for this connector are:

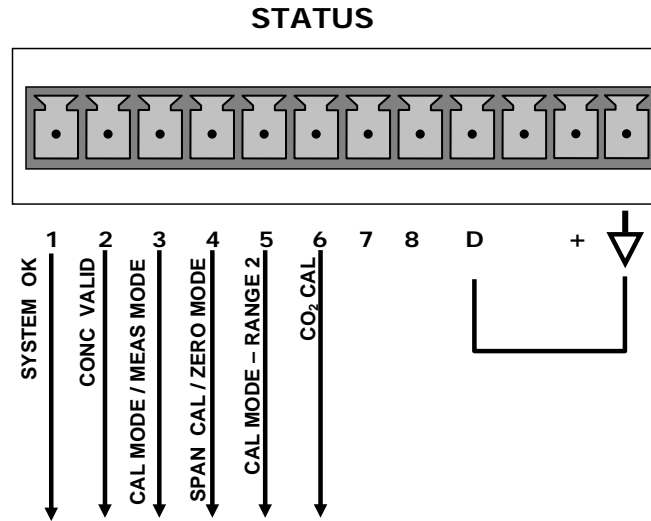

Figure 3-9: Status Output Connector

Table 3-6: Status Output Signals

Rear Panel Label	Status Definition	Condition
1	SYSTEM OK/ALARM	ON if no faults are present. OFF if alarm condition
2	CONC VALID/CONC INVALID	ON if concentration measurement is valid. OFF any time the HOLD OFF feature is active, such as during calibration or when any faults exist invalidating the measurement.
3	CAL MODE/ MEAS MODE	ON whenever the instrument is in Calibration Mode OFF when instrument in Measure Mode
4	SPAN/ZERO CAL	ON whenever the instrument's SPAN point is being calibrated. OFF whenever the instrument's ZERO point is being calibrated.
5	RANGE2 CAL RANGE1 CAL	ON if unit is in high range of either the DUAL or AUTO range modes. OFF if unit is in default low, single range mode
6	CO ₂ /O ₂ Sensor CAL	ON when CO ₂ sensor is in calibration mode. OFF when O ₂ sensor is in calibration mode.
7 & 8	SPARE	
D	EMITTER BUS	The emitters of the transistors on Pins 1-8 are bussed together.
+	DC POWER	+ 5 VDC, 300 mA source (combined rating with Control Output, if used).
⏚	Digital Ground	The ground level from the analyzer's internal DC power supplies

3.3.1.6. CONNECTING THE CONTROL INPUTS

If you wish to use the analyzer to remotely activate the zero and span calibration modes, several digital control inputs are provided through a 10-pin connector labeled **CONTROL IN** on the analyzer's rear panel.

There are two methods for energizing the control inputs. The internal +5V available from the pin labeled "+" is the most convenient method (Figure 3-10,

left). However, if full isolation is required, an external 5 VDC power supply should be used (Figure 3-10, right).

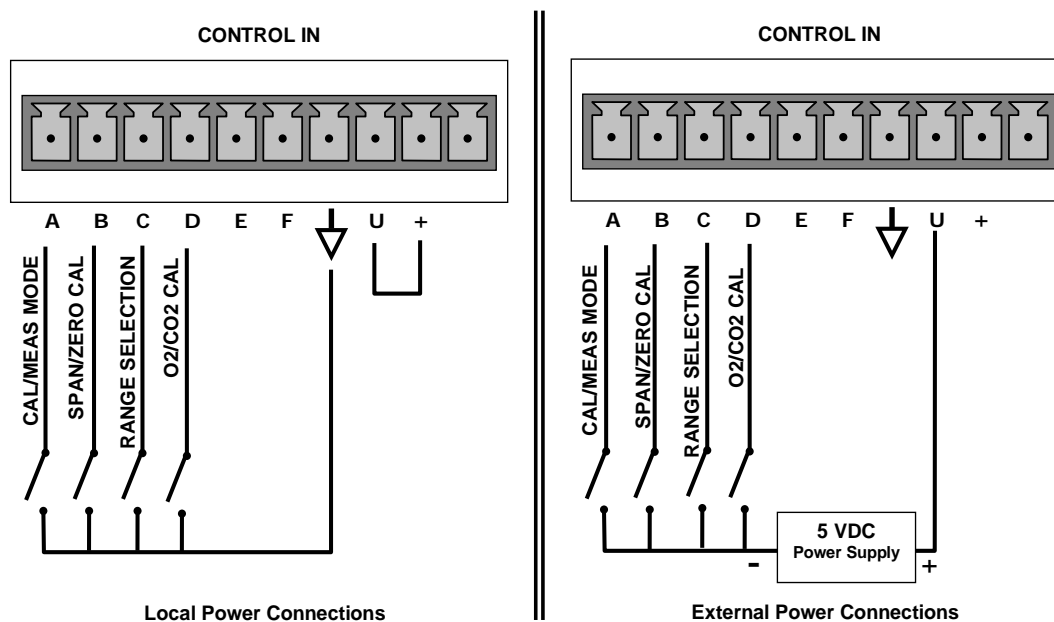

Figure 3-10: Control Input Connector

Table 3-7: Control Input Signals

Input #	Status Definition	Open/Closed Condition Description
A	CALIBRATION MODE or MEASURE MODE	Open: initiates Calibration mode. The mode field of the front panel display will read CO2 CAL R , CO2 CAL ZR , O2 CAL R or O2 CAL ZR Closed: initiates Measure mode. The mode field of the front panel display will read CO2 R , CO2 ZR , O2 R , or O2 ZR
B	REMOTE SPAN or REMOTE ZERO CALIBRATION	Open: initiates remote SPAN calibration mode as part of performing a low span calibration. The mode field of the front panel display will read CO2 CAL SR or O2 CAL SR . Closed: initiates remote ZERO calibration mode. The mode field of the front panel display will read ZERO MODE .
C	RANGE2 or RANGE1 CALIBRATION	Open: selects Range 2 for calibration. Closed: selects Range 1, default range in single range mode.
D	O₂ SENSOR or CO₂ SENSOR CALIBRATION	Open: initiates calibration of the O ₂ sensor. The mode field of the front panel display will read O2 CAL R or O2 CAL ZR . Closed: Initiates calibration of the CO ₂ sensor. The mode field of the front panel display will read CO2 CAL R or CO2 CAL ZR
E & F	SPARE	
▽	Digital Ground	The ground level from the analyzer's internal DC power supplies (same as chassis ground)
U	External Power input	Input pin for +5 VDC required to activate Pins A – F.
+	5 VDC output	Internally generated 5V DC power. To activate inputs A – F, place a jumper between this pin and the "U" pin. The maximum amperage through this port is 300 mA (combined with the analog output supply, if used).

3.3.1.7. CONCENTRATION ALARM RELAY (OPTION 61)

The Teledyne API T-Series analyzers have an option for four (4) “dry contact” relays on the rear panel of the instrument. This relay option is different from and in addition to the “Contact Closures” that come standard on all TAPI instruments. The relays have three pins that have connections on the rear panel (refer Figure 3-11). They are a Common (C), a Normally Open (NO), and a Normally Closed (NC) pin.

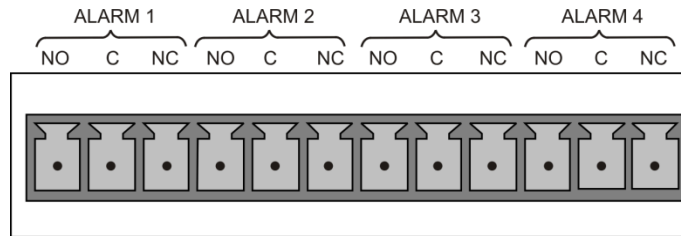

Figure 3-11: Concentration Alarm Relay

Alarm 1	“System OK 2”
Alarm 2	“Conc 1”
Alarm 3	“Conc 2”
Alarm 4	“Range Bit”

“ALARM 1” RELAY

Alarm 1 which is “System OK 2” (system OK 1, is the status bit) is in the energized state when the instrument is “OK” & there are no warnings. If there is a warning active or if the instrument is put into the “DIAG” mode, Alarm 1 will change states. This alarm has “reverse logic” meaning that if you put a meter across the Common & Normally Closed pins on the connector you will find that it is OPEN when the instrument is OK. This is so that if the instrument should turn off or lose power, it will change states & you can record this with a data logger or other recording device.

“ALARM 2” RELAY & “ALARM 3” RELAY

The “Alarm 2 Relay” on the rear panel, is associated with the “Concentration Alarm 1” set point in the software & the “Alarm 3 Relay” on the rear panel is associated with the “Concentration Alarm 2” set point in the software.

Alarm 2 Relay	CO ₂ Alarm 1 = xxx %
Alarm 3 Relay	CO ₂ Alarm 2 = xxx %
Alarm 2 Relay	O ₂ Alarm 1 = xxx %
Alarm 3 Relay	O ₂ Alarm 2 = xxx %

The Alarm 2 Relay will be turned on any time the concentration set-point is exceeded & will return to its normal state when the concentration value goes back below the concentration set-point.

Even though the relay on the rear panel is a NON-Latching alarm & resets when the concentration goes back below the alarm set point, the warning on the front panel of the instrument will remain latched until it is cleared. You can clear the warning on the front panel by either pushing the CLR button on the front panel or through the serial port.

The software for this instrument is flexible enough to allow you to configure the alarms so that you can have 2 alarm levels for each gas.

CO₂ Alarm 1 = 20 %
CO₂ Alarm 2 = 100 %
O₂ Alarm 1 = 20 %
O₂ Alarm 2 = 100 %

In this example, O₂ Alarm 1 & CO₂ Alarm 1 will both be associated with the “Alarm 2” relay on the rear panel. This allows you to have multiple alarm levels for individual gases.

A more likely configuration for this would be to put one gas on the “Alarm 1” relay and the other gas on the “Alarm 2” relay.

CO₂ Alarm 1 = 20 %
CO₂ Alarm 2 = Disabled
O₂ Alarm 1 = Disabled
O₂ Alarm 2 = 80 %

“ALARM 4” RELAY

This relay is connected to the “range bit”. If the instrument is configured for “Auto Range”, and the instrument goes up into the high range, it will turn this relay on.

3.3.1.8. COMMUNICATION CONNECTIONS

The T-Series analyzers are equipped with connectors for remote communications interfaces: Ethernet, USB, RS-232, optional RS-232 Multidrop, and optional RS-485. In addition to using the appropriate cables (Table 1-1 describes the cable options, 60A through 60D), each type of communication method must be configured using the SETUP>COMM menu.

ETHERNET CONNECTION

For network or Internet communication with the analyzer, connect an Ethernet cable from the analyzer’s rear panel Ethernet interface connector to an Ethernet port. Please refer to Section 6.3 for a description of the default configuration and setup instructions.

USB OPTION CONNECTION

For direct communication between the analyzer and a personal computer (PC), connect a USB cable between the analyzer and desktop or laptop USB ports. (If this option is installed, the COM2 port can only be used for RS232 multidrop communication). USB download is required (Section 6.4).

RS-232 CONNECTION

For **RS-232** communications with data terminal equipment (**DTE**) or with data communication equipment (**DCE**) connect the applicable cable option (Table 1-1: either a DB9-female-to-DB25-male cable, Option 60A, or a DB9-female-to-DB9-female cable, Option 60B) from the analyzer’s rear panel RS-232 port to the device. Adjust the DCE-DTE switch located on the rear panel (Figure 3-4) to select DTE or DCE as appropriate (Section 6.1).

IMPORTANT**IMPACT ON READINGS OR DATA**

Cables that appear to be compatible because of matching connectors may incorporate internal wiring that makes the link inoperable. Check cables acquired from sources other than Teledyne API for pin assignments before using.

Received from the factory, the analyzer is set up to emulate a DCE or modem, with Pin 3 of the DB-9 connector designated for receiving data and Pin 2 designated for sending data..

- **COM1:** RS-232 (fixed) DB-9 male connector
 - Baud rate: 115200 bits per second (baud)
 - Data Bits: 8 data bits with 1 stop bit
 - Parity: None
- **COM2:** RS-232 (configurable to RS 485), DB-9 female connector
 - Baud rate:19200 bits per second (baud)
 - Data Bits: 8 data bits with 1 stop bit
 - Parity: None

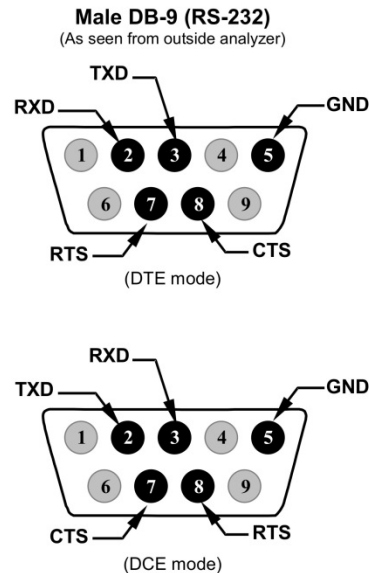

Figure 3-12: Default Pin Assignments, Rear Panel COM Port Connectors

The signals from these two connectors are routed from the motherboard via a wiring harness to two 10-pin connectors on the CPU card, J11 and J12.

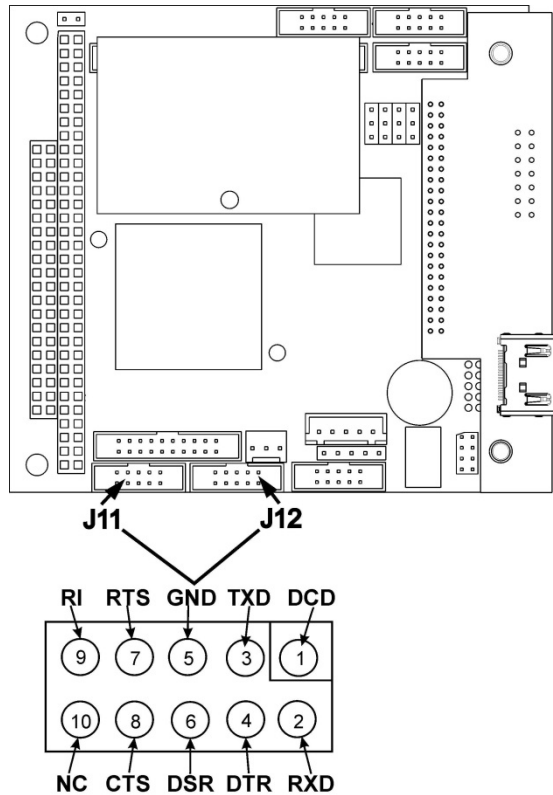

Figure 3-13: CPU Connector Pin-Outs for RS-232 Mode

To assist in properly connecting the serial ports to either a computer or a modem, there are activity indicators just above the RS-232 port. Once a cable is connected between the analyzer and a computer or modem, both the red and green LEDs should be on.

- If the lights are not lit, use the small switch on the rear panel to switch it between DTE and DCE modes

If both LEDs are still not illuminated, make sure the cable is properly constructed.

RS-232 MULTIDROP OPTION CONNECTION

When the RS-232 Multidrop option is installed, connection adjustments and configuration through the menu system are required. This section provides instructions for the internal connection adjustments, then for external connections, and ends with instructions for menu-driven configuration.

Note

Because the RS-232 Multidrop option uses both the RS232 and COM2 DB9 connectors on the analyzer's rear panel to connect the chain of instruments, COM2 port is no longer available for separate RS-232 or RS-485 operation.

ATTENTION**-----
COULD DAMAGE INSTRUMENT AND VOID WARRANTY**

Printed Circuit Assemblies (PCAs) are sensitive to electro-static discharges too small to be felt by the human nervous system. Failure to use ESD protection when working with electronic assemblies will void the instrument warranty. For information on prevent ESD damage, refer to the manual, *Fundamentals of ESD, A Primer on Electro-Static Discharge*, downloadable from our website.

In each instrument with the Multidrop option there is a shunt jumpering two pins on the serial Multidrop and LVDS printed circuit assembly (PCA), as shown in Figure 3-14. This shunt must be removed from all instruments except that designated as last in the multidrop chain, which must remain terminated. This requires powering off and opening each instrument and making the following adjustments:

1. With **NO power** to the instrument, remove its top cover and lay the rear panel open for access to the Multidrop/LVDS PCA, which is seated on the CPU.
2. On the Multidrop/LVDS PCA's JP2 connector, remove the shunt that jumpers Pins 21 ↔ 22 as indicated in Figure 3-14. (Do this for all but the last instrument in the chain where the shunt should remain at Pins 21 ↔ 22).
3. Check that the following cable connections are made in *all* instruments (again refer to Figure 3-14):
 - J3 on the Multidrop/LVDS PCA to the CPU's COM1 connector
(Note that the CPU's COM2 connector is not used in Multidrop)
 - J4 on the Multidrop/LVDS PCA to J12 on the motherboard
 - J1 on the Multidrop/LVDS PCS to the front panel LCD

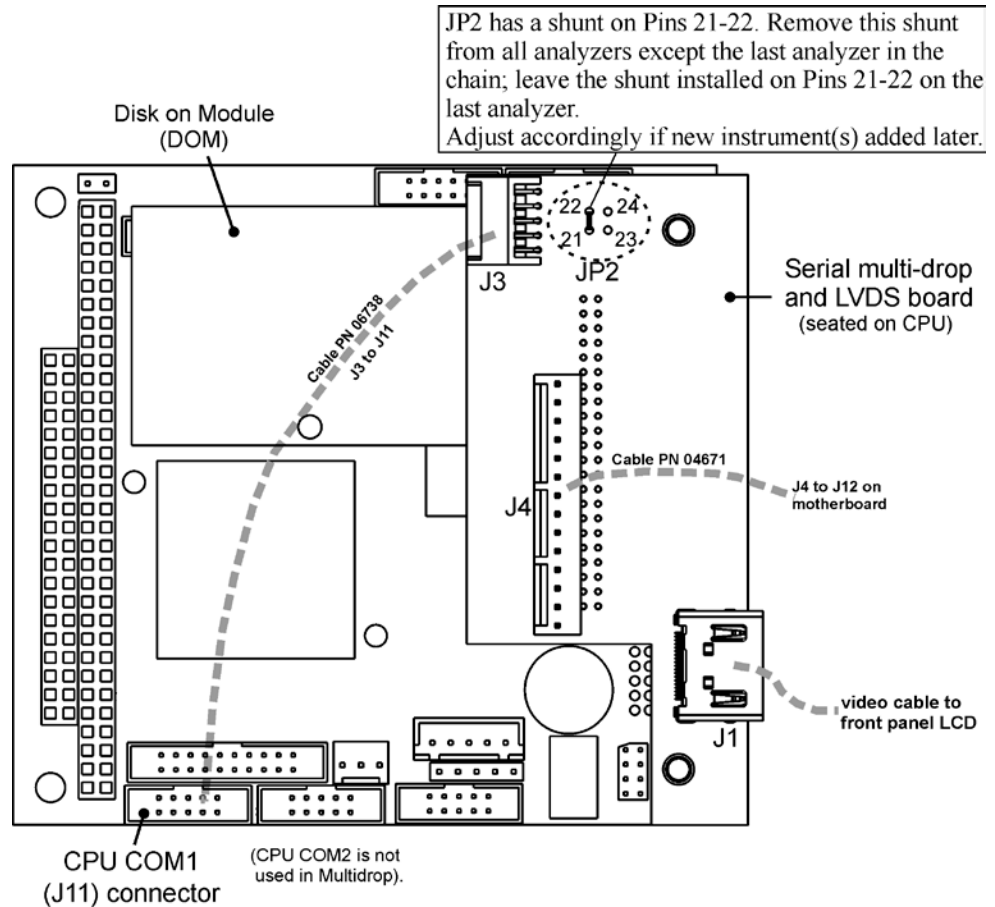

Figure 3-14: Jumper and Cables for Multidrop Mode

(Note: If you are adding an instrument to the end of a previously configured chain, remove the shunt between Pins 21 ↔ 22 of JP2 on the Multidrop/LVDS PCA in the instrument that was previously the last instrument in the chain.)

4. Close the instrument.
5. Referring to Figure 3-15 use straight-through DB9 male → DB9 female cables to interconnect the host RS232 port to the first analyzer's RS232 port; then from the first analyzer's COM2 port to the second analyzer's RS232 port; from the second analyzer's COM2 port to the third analyzer's RS232 port, etc., connecting in this fashion up to eight analyzers, subject to the distance limitations of the RS-232 standard.
6. On the rear panel of each analyzer, adjust the DCE DTE switch so that the green and the red LEDs (RX and TX) of the COM1 connector (labeled RS232) are both lit. (Ensure you are using the correct RS-232 cables internally wired specifically for RS-232 communication; see Table 1-1, "Communication Cables" and the preceding subsection, "RS-232 Connection").

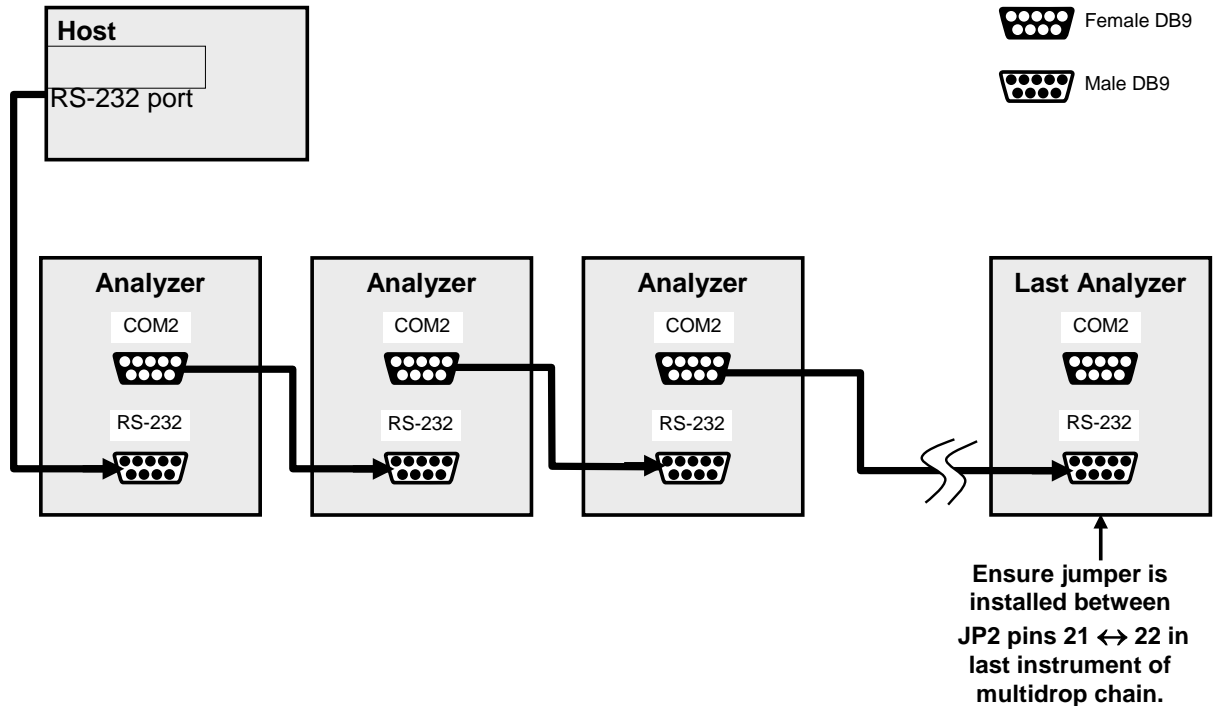

Figure 3-15: RS-232-Multidrop PCA Host/Analyzer Interconnect Diagram

7. BEFORE communicating from the host, power on the instruments and check that the Machine ID is unique for each (Section 6.2.4).
 - a. In the SETUP Mode menu go to SETUP>MORE>COMM>ID. The default ID is typically the model number or "0".
 - b. to change the identification number, press the button below the digit to be changed.
 - c. Press/select ENTER to accept the new ID for that instrument.
8. Next, in the SETUP>MORE>COMM>COM1 menu (do not use the COM2 menu for multidrop), edit the COM1 MODE parameter as follows: press/select EDIT and set only QUIET MODE, COMPUTER MODE, and MULTIDROP MODE to ON. Do not change any other settings.
9. Press/select ENTER to accept the changed settings, and ensure that COM1 MODE now shows 35.
10. Press/select SET> to go to the COM1 BAUD RATE menu and ensure it reads the same for all instruments (edit as needed so that all instruments are set at the same baud rate).

Note

Teledyne API recommends setting up the first link, between the Host and the first analyzer, and testing it before setting up the rest of the chain.

Note

The (communication) Host instrument can address only one instrument at a time, each by its unique ID (see step 7 above).

RS-485 CONNECTION

As delivered from the factory, **COM2** is configured for RS-232 communications. This port can be reconfigured for operation as a non-isolated, half-duplex RS-485 port. Using COM2 for RS-485 communication will disable the USB port. To reconfigure this port for RS-485 communication, please contact the factory.

3.3.2. PNEUMATIC CONNECTIONS

CAUTION – GENERAL SAFETY HAZARD: CO₂



While CO₂ itself is not toxic, in sufficient concentrations it can be an irritant and an asphyxiant.

Obtain a Material Safety Data Sheet for CO₂ and any other hazardous components of sample and calibration gases, and follow the prescribed safety guidelines.

Do not vent sample gases into the immediate vicinity of the analyzer nor into any enclosed areas.

CAUTION – GENERAL SAFETY HAZARD: O₂



While O₂ is itself not toxic, the sample gas measured by, and in some cases the calibration gases used with the T803 can contain other components that are hazardous (e.g. NO, NO₂, SO₂, CO, etc).

Obtain a Material Safety Data Sheet (MSDS) for each such gas. Read and rigorously follow the safety guidelines described there.

Do not vent sample gases containing hazardous components into enclosed areas.

3.3.2.1. CALIBRATION GASES

3.3.2.2. ZERO GAS

Zero gas is similar in chemical composition to the earth's atmosphere but scrubbed of all components that might affect the analyzer's readings. Teledyne API recommends using pure N₂ when calibrating the zero point of your O₂ and CO₂ sensors.

CAUTION – GENERAL SAFETY HAZARD



Rapid release of pure N₂ gas into an enclosed space can displace oxygen, and therefore represents an asphyxiation hazard. This may happen with few warning symptoms.

Do not vent calibration gases into enclosed areas.

3.3.2.3. SPAN GAS

Span gas is specifically mixed to match the chemical composition of the type of gas being measured at near full scale of the desired measurement range. Teledyne API recommends the following when calibrating the span point of each sensor:

- O₂ sensor: 21% O₂ in N₂
- CO₂ sensor: 16% CO₂ in N₂

Cylinders of calibrated gas traceable to NIST-Standard Reference Material specifications (also referred to as SRMs or EPA protocol calibration gases) are commercially available.

3.3.2.4. INTERFERENTS

Some gases, if present in the sample stream in high concentrations, could potentially interfere with the analyzer. For example, if the Sample Gas to be measured contains high levels of nitrogen dioxide (NO₂) and/or nitrous oxide (NO), the gases used for both the zero point calibration and the span calibration should contain the same components in the same proportion in order to cancel any interference effects.

3.3.2.5. BASIC PNEUMATIC CONNECTIONS

See Figure 3-4 and Table 3-3 for the location and descriptions of the various pneumatic inlets/outlets referred to in this section.



CAUTION – GENERAL SAFETY HAZARD

Sample and calibration gases should only come into contact with Stainless Steel, PTFE (Teflon) tubing, glass or electroless nickel.

The exhaust from the analyzer's internal or customer supplied external pump MUST be vented outside the immediate area or shelter surrounding the instrument.

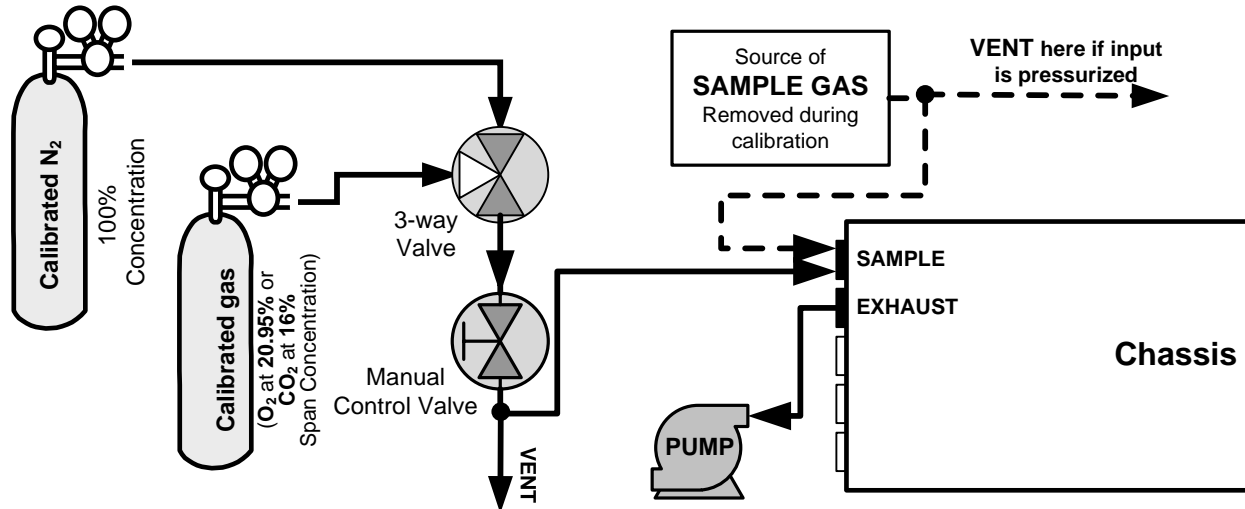

Figure 3-16: Pneumatic Connections, Using Bottled Span Gas

3.3.2.6. SAMPLE GAS SOURCE

Attach a sample inlet line to the **SAMPLE** inlet port. The SAMPLE input line should not be more than two (2) meters long.

- Maximum pressure of any gas at the SAMPLE inlet should not exceed 1.5 in-Hg above ambient pressure and ideally should equal ambient atmospheric pressure.
- In applications where the sample gas is received from a pressurized manifold, a vent must be placed on the sample gas before it enters the analyzer. Please refer to Figure 3-16.

3.3.2.7. CALIBRATION GAS SOURCES

The source of calibration gas is also attached to the **SAMPLE** inlet, but only when a calibration operation is actually being performed.

Note

Zero air and span gas flows should be supplied in excess of the 120 cm³/min demand of the analyzer.

3.3.2.8. INPUT GAS VENTING

The span gas, zero air supply and sample gas (if pressurized) line **MUST** be vented (Figure 3-16) for two reasons: in order to ensure that the gases input do not exceed the maximum inlet pressure of the analyzer, and to prevent back diffusion and pressure effects. These vents should be:

- At least 0.2m long;
- No more than 2m long and;
- Vented outside the shelter or at least into a well-ventilated area and away from the immediate area surrounding the instrument

3.3.2.9. EXHAUST OUTLET

Attach an exhaust line to the analyzer's EXHAUST outlet fitting. The exhaust line should be:

- PTEF tubing; minimum O.D ¼"
- A maximum of 10 meters long.
- Vented outside the T803 analyzer's enclosure, preferably outside the shelter or at least into a well-ventilated area.

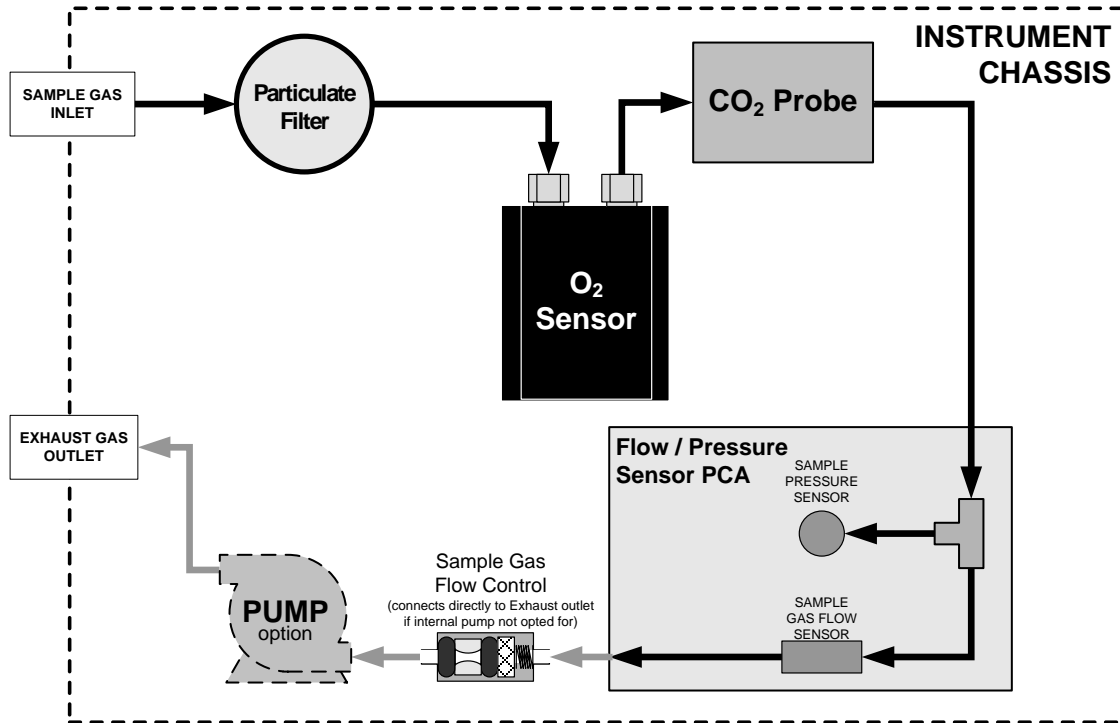

Figure 3-17: T803 Internal Gas Flow

IMPORTANT

Leak Check:

Run a leak check once the appropriate pneumatic connections have been made; check all pneumatic fittings for leaks using the procedures defined in Section 10.3.3.

3.4. STARTUP, FUNCTIONAL CHECKS, AND INITIAL CALIBRATION

IMPORTANT

IMPACT ON READINGS OR DATA

The analyzer's cover must be installed to ensure that the temperatures of the internal components are properly controlled.

If you are unfamiliar with the theory of operation, we recommend that you read Section 12. For information on navigating the analyzer's software menus, see the menu trees described in Appendix A.1.

3.4.1. STARTUP

After the electrical and pneumatic connections are made, turn on the instrument. The pump and exhaust fan should start immediately. The analyzer should automatically switch to Sample Mode after completing the boot-up sequence and start monitoring CO₂ and O₂ gases.

3.4.2. WARM UP

The T803 requires about 60 minutes warm-up time before reliable measurements can be taken. During that time, various portions of the instrument's front panel will behave as follows. See Figure 3-1 for locations.

Table 3-8: Front Panel Display during System Warm-Up

FIELD	COLOR	BEHAVIOR	SIGNIFICANCE
Conc (Concentration)	N/A	Displays current, compensated CO ₂ /O ₂ concentration	This is normal operation, but deemed inaccurate during the warm-up period.
Mode	N/A	Displays blinking "SAMPLE"	Instrument is in sample mode but is still in the process of warming up.
Param (Parameters)	N/A	Displays menus, parameters, and messages.	Use any warning messages as a means of diagnosing problems.
STATUS LEDS			
Sample	Green	On	Unit is operating in sample mode; front panel display is being updated.
Cal	Yellow	Off	The instrument's calibration is not enabled.
Fault	Red	Blinking	The analyzer is warming up and hence out of specification for a fault-free reading. various warning messages appear in the Param field.

3.5. WARNING MESSAGES

Because internal temperatures and other conditions may be outside the specified limits during the analyzer's warm-up period, the software will suppress most warning conditions for 30 minutes after power up. If warning messages persist after the 60-minute warm up period is over, investigate their cause using the troubleshooting guidelines in Section 11.

Table 3-9: Warning Messages

MESSAGE	DEFINITION
ANALOG CAL WARNING	The instrument's A/D circuitry or one of its analog outputs is not calibrated.
BOX TEMP WARNING	The temperature inside the T803 chassis is outside the specified limits.
CANNOT DYN SPAN²	Remote span calibration failed while the dynamic span feature was set to ON
CANNOT DYN ZERO³	Remote zero calibration failed while the dynamic zero feature was set to ON
CONFIG INITIALIZED	Configuration was reset to factory defaults or was erased.
CO₂ ALRM1 WARNING⁴	CO ₂ concentration alarm limit 1 exceeded
CO₂ ALRM2 WARNING⁴	CO ₂ concentration alarm limit 2 exceeded
CO₂ CELL TEMP WARN	CO ₂ sensor cell temperature outside of warning limits specified by <i>CO₂_CELL_SET</i> variable.
DATA INITIALIZED	DAS data storage was erased.
O₂ ALRM1 WARNING⁴	O ₂ concentration alarm limit 1 exceeded
O₂ ALRM2 WARNING⁴	O ₂ concentration alarm limit 2 exceeded
O₂ CELL TEMP WARN	O ₂ sensor cell temperature outside of warning limits specified by <i>O₂_CELL_SET</i> variable.
REAR BOARD NOT DET	CPU unable to communicate with the motherboard.
RELAY BOARD WARN	CPU is unable to communicate with the relay PCA.
SAMPLE FLOW WARN	The flow rate of the sample gas is outside the specified limits.
SAMPLE PRESS WARN	Sample gas pressure outside of operational parameters.
SYSTEM RESET¹	The analyzer was rebooted or the CPU was reset.
¹ Does not clear after power up. ² Clears the next time successful zero calibration is performed. ³ Clears the next time successful span calibration is performed. ⁴ Only active if the Concentration Alarm Option is installed	

To view and clear warning messages:

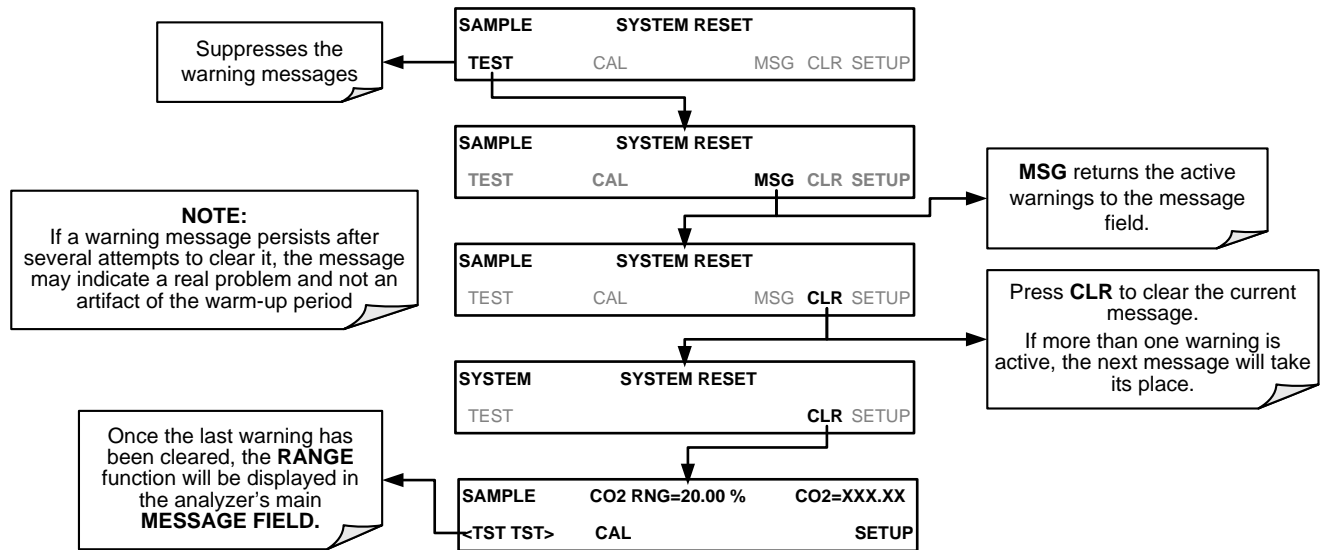

Figure 3-18: Viewing and Clearing T803 WARNING Messages

3.5.1. FUNCTIONAL CHECK

After the analyzer's components have warmed up for at least 60 minutes, verify that the software properly supports any hardware options that were installed. For information on navigating through the analyzer's software menus, see the menu trees described in Appendix A.1.

Check to make sure that the analyzer is functioning within allowable operating parameters. Appendix C includes a list of test functions, viewable from the analyzer's front panel, and their expected values. (These functions are also useful tools for diagnosing performance problems (Section 11.1.2) with your analyzer).

The enclosed Final Test and Validation Data Sheet (PN 068360000) lists these values before the instrument left the factory. To view the current values of these parameters, press the front panel button sequence for TEST functions as shown in Figure 6.2 in Section 6.2. Remember until the unit has completed its warm up these parameters may not have stabilized.

If your local area network is running a dynamic host configuration protocol (DHCP) software package, the Ethernet will automatically configure its interface with your LAN.

- However, it is a good idea to check these settings to make sure that the DHCP has successfully downloaded the appropriate network settings from your network server (see Section 6.3.1).
- If your network is not running DHCP, you will have to configure the analyzer's interface manually (see Section 6.3.2).

3.5.2. INITIAL CALIBRATION

To perform the calibration you must have sources for zero air and span gas available for input into the SAMPLE port on the back of the analyzer. See Section 0 for instructions for connecting these gas sources.

The initial calibration should be carried out using the same reporting range set up as used during the analyzer's factory calibration. This will allow you to compare your calibration results to the factory calibration as listed on the *Final Test and Validation Data Sheet*.

If both available DAS parameters for a specific gas type are being reported via the instrument's analog outputs e.g. **CONC1** and **CONC2** when the **DUAL** range mode is activated, separate calibrations should be carried out for each parameter.

- Use the **RNG1** button when calibrating for **CONC1** (equivalent to **LOW RANGE**).
- Use the **RNG2** button when calibrating for **CONC2** (equivalent to **HIGH RANGE**).

The calibration procedures assume:

- that the zero point and span gases have been adjusted for known interferences (Section 3.3.2.4)
- that the Calibration gas will be supplied through the SAMPLE port
- that the pneumatic setup matches that described in Section 0.

Perform the following outline of procedures for each sensor:

1. Verify the Reporting Range settings as presented in Section 5.4.3. We recommend that you perform this initial checkout using the following reporting range settings:
 - Mode Setting: **SNGL**
 - Analog Output Reporting Range: **16% for CO₂** and **20.95% for O₂**
2. If the Dilution Ratio Option is enabled on your T803, perform the Dilution Ratio set up as presented in Section 5.4.4
3. Set the expected Span Gas Concentration for CO₂ and for O₂, as presented in Section 9.2.3.1. This should be 80% of concentration range for which the analyzer's analog output range is set.
4. Perform the Zero/Span point calibration presented in Section 9.2.3.2

The analyzer is now ready for operation.

Note

Once you have completed the above set-up procedures, please fill out the Quality Questionnaire that was shipped with your unit and return it to Teledyne API. This information is vital to our efforts in continuously improving our service and our products. THANK YOU.

This page intentionally left blank.

4. BASIC OPERATION

The T803 analyzer is a computer-controlled analyzer with a dynamic menu interface that allows all major operations to be controlled from the front panel touchscreen through user-friendly menus (A complete set of menu trees is located in Appendix A of this manual)

This section includes step-by-step instructions for using the display/touchscreen to set up and operate the analyzer's basic CO₂ and O₂ measurement features and functional modes.

4.1. OVERVIEW OF OPERATING MODES

The T803 software has several operating modes (Table 6-1), and most commonly operates in **SAMPLE** mode. In this mode a continuous read-out of the gas concentration is displayed on the front panel. **SAMPLE** mode is used to:

- perform calibrations
- run test functions
- read and clear warning messages
- output analog data (when enabled)

The next most commonly used operating mode is **SETUP** mode, which is used to;

- perform certain configuration operations, such as programming the DAS system or the configurable analog output channels
- set up the analyzer's serial communication channels (RS-232, RS-485, Ethernet)
- perform various diagnostic tests during troubleshooting



Figure 4-1: Front Panel Display

The mode field of the front panel display indicates to the user which operating mode the unit is currently running.

In addition to **SAMPLE** and **SETUP**, other modes the analyzer can be operated in are:

Table 4-1: Analyzer Operating Modes

MODE	DESCRIPTION
SAMPLE	Sampling normally, flashing text indicates adaptive filter is on.
SAMPLE A	Indicates that unit is in Sample Mode while AUTOCAL feature is active.
CO2 M-P CAL	This is the basic calibration mode of the instrument and is activated by pressing the CAL button.
SETUP [X.X]	SETUP mode is being used to configure the analyzer. The gas measurement will continue during this process. The revision of the T803 firmware being run will appear after the word " SETUP "
CAL CO2 Z[type]^{2 & 3}	Unit is performing CO ₂ ZERO calibration procedure.
CAL CO2 S[type]^{2 & 3}	Unit is performing CO ₂ SPAN calibration procedure.
CAL O2 Z[type]^{2 & 3}	Unit is performing O ₂ ZERO calibration procedure.
CAL O2 S[type]^{2 & 3}	Unit is performing O ₂ SPAN calibration procedure.
DIAG Mode	One of the analyzer's diagnostic modes is active (Section 5.9).
[type:]	
² M: initiated manually by the user via the front panel touchscreen.	
³ R: initiated remotely through the COM ports or digital control inputs.	

4.2. SAMPLE MODE

This is the analyzer's standard operating mode. In this mode the instrument is analyzing the gas in the sample chamber, calculating CO₂ and O₂ concentrations and reporting this information to the user via the front panel display, the analog outputs and, if set up properly, the RS-232/485/Ethernet ports.

A variety of **TEST** functions are available for viewing at the front panel whenever the analyzer is at the **MAIN MENU**. These functions provide information about the various functional parameters related to the analyzers operation and its measurement of gas concentrations. This information is particularly useful when troubleshooting a performance problem (see Section 11.1.2).

To view these **TEST** functions, press,

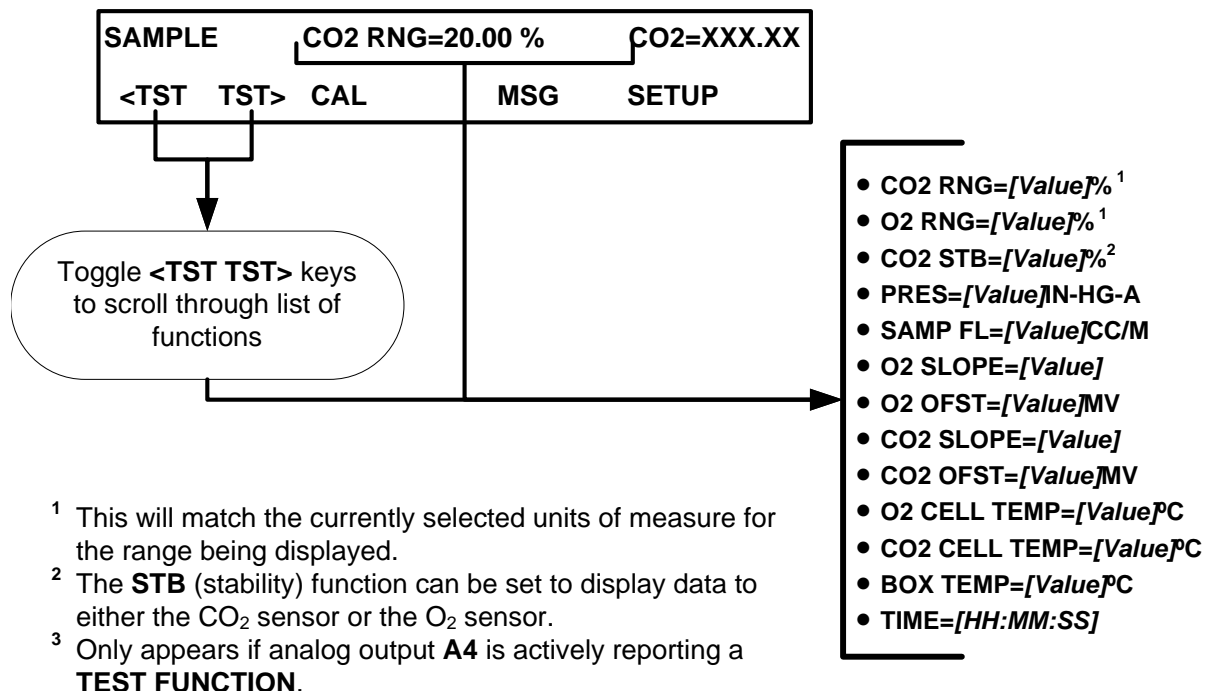

Figure 4-2: Viewing T803 Test Functions

Note A value of "Warnings" displayed for any of the TEST functions indicates an out-of-range reading or the analyzer's inability to calculate it.

Note All pressure measurements are represented in terms of absolute pressure. Absolute, atmospheric pressure is 29.92 in-Hg-A at sea level. It decreases about 1 in-Hg per 300 m gain in altitude. A variety of factors such as air conditioning and passing storms can cause changes in the absolute atmospheric pressure.

Table 4-2: Test Functions Defined

PARAMETER	DISPLAY TITLE	UNITS	DEFINITION
Range	RNG RN1 RN2	%	The full scale limit at which the reporting range of the analyzer is currently set. THIS IS NOT the Physical Range of the instrument. See Section 5.4.1 for more information.
Stability	STB	%	Standard deviation of CO ₂ concentration readings. Data points are recorded every ten seconds using the last 25 data points. This function can be reset to show O ₂ or CO ₂ stability.
Sample Pressure	PRES	In-Hg-A	The absolute pressure of the Sample gas as measured by a pressure sensor located inside the sample chamber.
Sample Flow	SAMP FL	cm ³ /min	Sample mass flow rate as measured by the flow rate sensor in the sample gas stream.
CO ₂ Sensor Slope	CO2 SLOPE	-	CO ₂ slope, computed during zero/span calibration.
CO ₂ Sensor Offset	CO2 OFST	-	CO ₂ offset, computed during zero/span calibration.
Box Temperature	BOX TEMP	°C	The temperature inside the analyzer chassis.
CO ₂ Cell Temperature	CO2 CELL TEMP	°C	The current temperature of the CO ₂ sensor measurement cell.
O ₂ Cell Temperature	O2 CELL TEMP	°C	The current temperature of the O ₂ sensor measurement cell.
O ₂ Sensor Slope	O2 SLOPE	-	O ₂ slope, computed during zero/span calibration.
O ₂ Sensor Offset	O2 OFST	-	O ₂ offset, computed during zero/span calibration.
Current Time	TIME	-	The current time. This is used to create a time stamp on DAS readings, and by the AUTOCAL feature to trigger calibration events.

4.3. CALIBRATION MODE

The T803 will switch into calibration mode when the user presses the CAL button. In this mode the user can, in conjunction with introducing zero or span gases of known concentrations into the analyzer, cause it to adjust and recalculate the slope (gain) and offset of the its measurement range. This mode is also used to check the current calibration status of the instrument.

Section 9 provides more information about setting up and performing standard calibration operations or checks.

Note

It is recommended that span calibration be performed at 80% of full scale of the analyzer's currently selected reporting range.

EXAMPLES:

If the reporting range is set for 0 to 50%, an appropriate span point would be 40%.

If the of the reporting range is set for 0 to 100%, an appropriate span point would be 80%.

4.4. SETUP MODE

The **SETUP** mode is used to configure the analyzer's hardware and software features, perform diagnostic procedures, gather information on the instrument's performance and configure or access data from the internal data acquisition system (DAS).

Note

Any changes made to a variable during one of the **SETUP** procedures are not acknowledged by the instrument until the **ENTR** button is pressed. If the **EXIT** button is pressed before the **ENTR** button, the analyzer will beep to notify the user that the newly entered value has been lost.

For a visual representation of the software menu trees, refer to Appendix A-1.

The areas accessible under the **SETUP** mode are shown below:

Table 6-4: Primary Setup Mode Features and Functions

MODE OR FEATURE	MENU ITEM	DESCRIPTION	MANUAL SECTION
Analyzer Configuration	CFG	Lists key hardware and software configuration information	5.1
Auto Cal Feature	ACAL	(Special configuration; consult factory).	
Internal Data Acquisition (DAS)	DAS	Used to set up the DAS system and view recorded data	7.1
Analog Output Reporting Range Configuration	RNGE	Used to configure the output signals generated by the instruments Analog outputs.	5.2
Calibration Password Security	PASS	Turns the calibration password feature ON/OFF	5.5
Internal Clock Configuration	CLK	Used to Set or adjust the instrument's internal clock	5.6
Advanced SETUP features	MORE	This button accesses the instrument's secondary setup menu	See Table 6-5

Table 6-5: Secondary Setup Mode Features and Functions

MODE OR FEATURE	MENU ITEM	DESCRIPTION	MANUAL SECTION
External Communication Channel Configuration	COM	Used to set up and operate the analyzer's various external I/O channels including RS-232, RS-485, modem communication and/or Ethernet access.	5.7
System Status Variables	VARs	Used to view various variables related to the instruments current operational status <ul style="list-style-type: none"> • Changes made to any variable will not be recorded in the instrument's memory until the ENTR button is pressed. • Pressing the EXIT button ignores the new setting. 	5.5
System Diagnostic Features and Analog Output Configuration	DIAG	Used to access a variety of functions that configure, test or diagnose problems with a variety of the analyzer's basic systems. Most notably, the menus to configure the output signals generated by the instruments Analog outputs are located here.	5.9
Alarm Limit Configuration ¹	ALRM	Used to turn the instrument's two alarms on and off as well as set the trigger limits for each.	5.11
¹ Alarm warnings only present when optional concentration alarm relay package is installed.			

5. SETUP MENU

The SETUP menu is used to set instrument parameters for performing configuration, calibration, reporting and diagnostics operations.

5.1. SETUP → CFG: CONFIGURATION INFORMATION

Pressing the CFG button displays the instrument's configuration information. This display lists the analyzer model, serial number, firmware revision, software library revision, CPU type and other information.

- Special instrument or software features or installed options may also be listed here.
- Use this information to identify the software and hardware installed in your T803 analyzer when contacting Technical Support.

To access the configuration table, press:

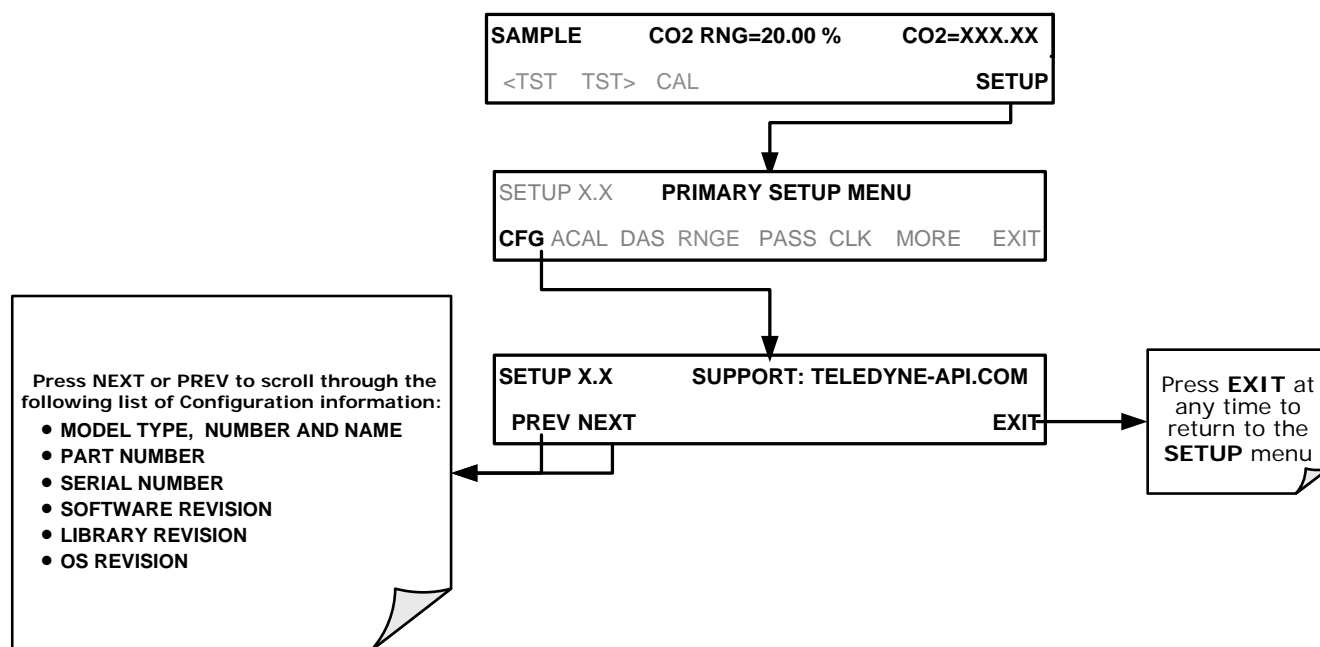

5.2. SETUP → ACAL: [NOT USED]

ACAL on the primary SETUP menu is a special configuration. Contact factory.

5.3. SETUP → DAS: INTERNAL DATA ACQUISITION SYSTEM

Use the SETUP>DAS menu to capture and record data. Refer to Section 7 for configuration and operation details.

5.4. SETUP → RNGE: ANALOG OUTPUT REPORTING RANGE CONFIGURATION

5.4.1. PHYSICAL RANGE VERSUS ANALOG OUTPUT REPORTING RANGES

Functionally, the T803 analyzers have one hardware PHYSICAL RANGE that is capable of determining concentrations from 0.00% to 100.00% for O₂; CO₂ is variable depending on the exact CO₂ sensor.

This architecture improves reliability and accuracy by avoiding the need for extra, switchable, gain-amplification circuitry. Once properly calibrated, the analyzer's front panel will accurately report concentrations along the entire span of its physical range.

Because many applications use only a small part of the analyzer's full physical range, data resolution problems can occur for most analog recording devices. For example, in a typical application where a T803 is being used to measure atmospheric O₂ concentration, the full scale of expected values is only 21% of the instrument's full measurement range. Unmodified, the corresponding output signal would also be recorded across only 21% of the range of the recording device.

The T803 analyzers solve this problem by allowing the user to select a scaled reporting range for the analog outputs that only includes that portion of the physical range relevant to the specific application.

Only this REPORTING RANGE of the analog outputs is scaled, the physical range of the analyzer and the readings displayed on the front panel remain unaltered.

Note

Both the DAS values stored in the CPU's memory and the concentration values reported on the front panel are unaffected by the settings chosen for the reporting range(s) of the instrument.

5.4.2. ANALOG OUTPUT RANGES FOR CO₂ AND O₂ CONCENTRATION

The analyzer has several active analog output signals accessible through a connector on the rear panel (see Figure 3-4).

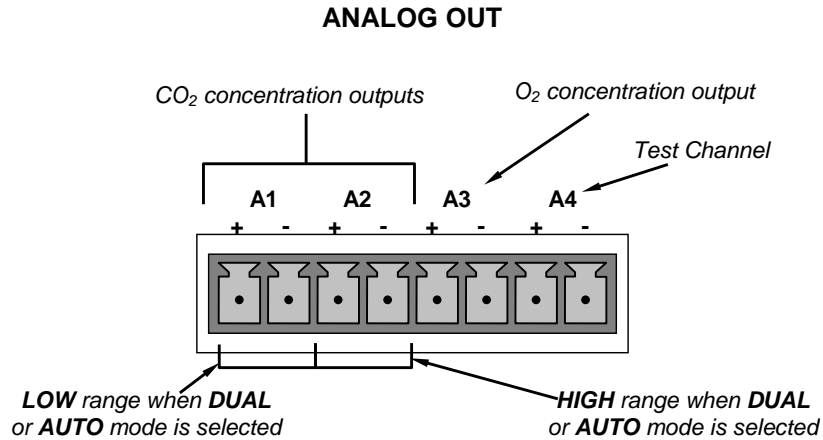

Figure 5-1: Analog Output Connector Pin Out

All three outputs can be configured either at the factory or by the user for full scale outputs of 0.1 VDC, 1VDC, 5VDC or 10VDC.

Additionally **A1**, **A2** and **A3** may be equipped with optional 0-20 mA current loop drivers and configured for any current output within that range (e.g. 0-20, 2-20, 4-20, etc.). The user may also adjust the signal level and scaling of the actual output voltage or current to match the input requirements of the recorder or datalogger (See Section 5.10.5).

When the instrument is in its default configuration, channels **A1** and **A2** (Dual or Auto range) output a signal proportional to the CO₂ concentration of the sample gas.(See Section 5.4.3).

Channel **A3** outputs a signal proportional to the O₂ concentration of the sample gas.

EXAMPLE:

A1 OUTPUT: Output Signal = 0-5 VDC representing 0- 20 % CO₂ concentration values

A3 OUTPUT: Output Signal = 0 – 10 VDC representing 0-100 % O₂concentration values.

The output, labeled **A4** is special. It can be set by the user (See Section 5.10.6) to output several of the test functions accessible through the <TST TST> buttons of the units sample display.

5.4.3. REPORTING RANGE MODES

The T803 provides three analog output range modes to choose from.

- Single range (**SNGL**) mode sets a single maximum range for the analog output. If single range is selected all three outputs are slaved together and will represent the same measurement span (e.g. 0-20 %), however their electronic signal levels may be configured for different ranges (e.g. 0-10 VDC vs. 0-0.1 VDC).
- Dual range (**DUAL**) allows the A1 and A2 outputs to be configured with different measurement spans as well as separate electronic signal levels.
- Auto range (**AUTO**) mode gives the analyzer the ability to output data via a low range and high range. When this mode is selected the analyzer will automatically switch between the two ranges dynamically as the concentration value fluctuates.

Range status is also output via the external digital I/O status outputs (See Section 3.3.1.4).

To select the Analog Output Range Type press:

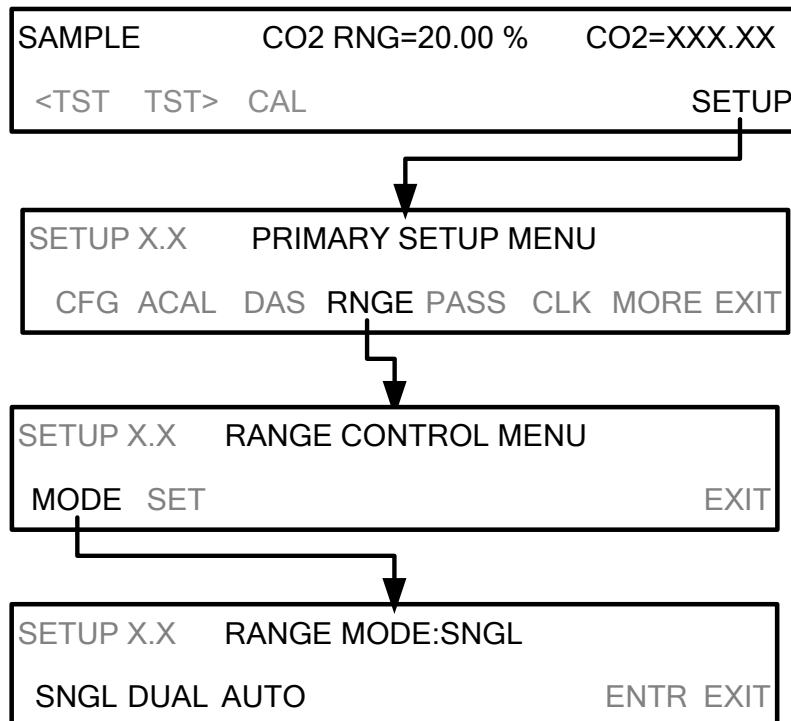

Upper span limit setting for the individual range modes are shared. Resetting the span limit in one mode also resets the span limit for the corresponding range in the other modes as follows:

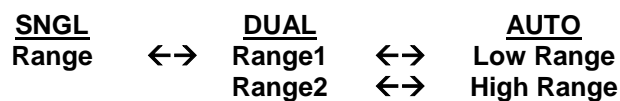

5.4.3.1. **RNGE → MODE → SNGL: CONFIGURING THE T803 ANALYZER FOR SINGLE RANGE MODE**

When the single range mode is selected (**SNGL**), all concentration outputs (**A1, A2 and A3**) are slaved together and set to the same reporting range limits (e.g. 0-22.00 %). The span limit of this reporting range can be set to any value within the physical range of the analyzer.

Although the outputs share the same concentration reporting range, the electronic signal ranges of the analog outputs may still be configured for different values (e.g. 0-5 VDC, 0-10 VDC, etc; see Section 5.10.2)

To select **SNGL** range mode and to set the upper limit of the range, press:

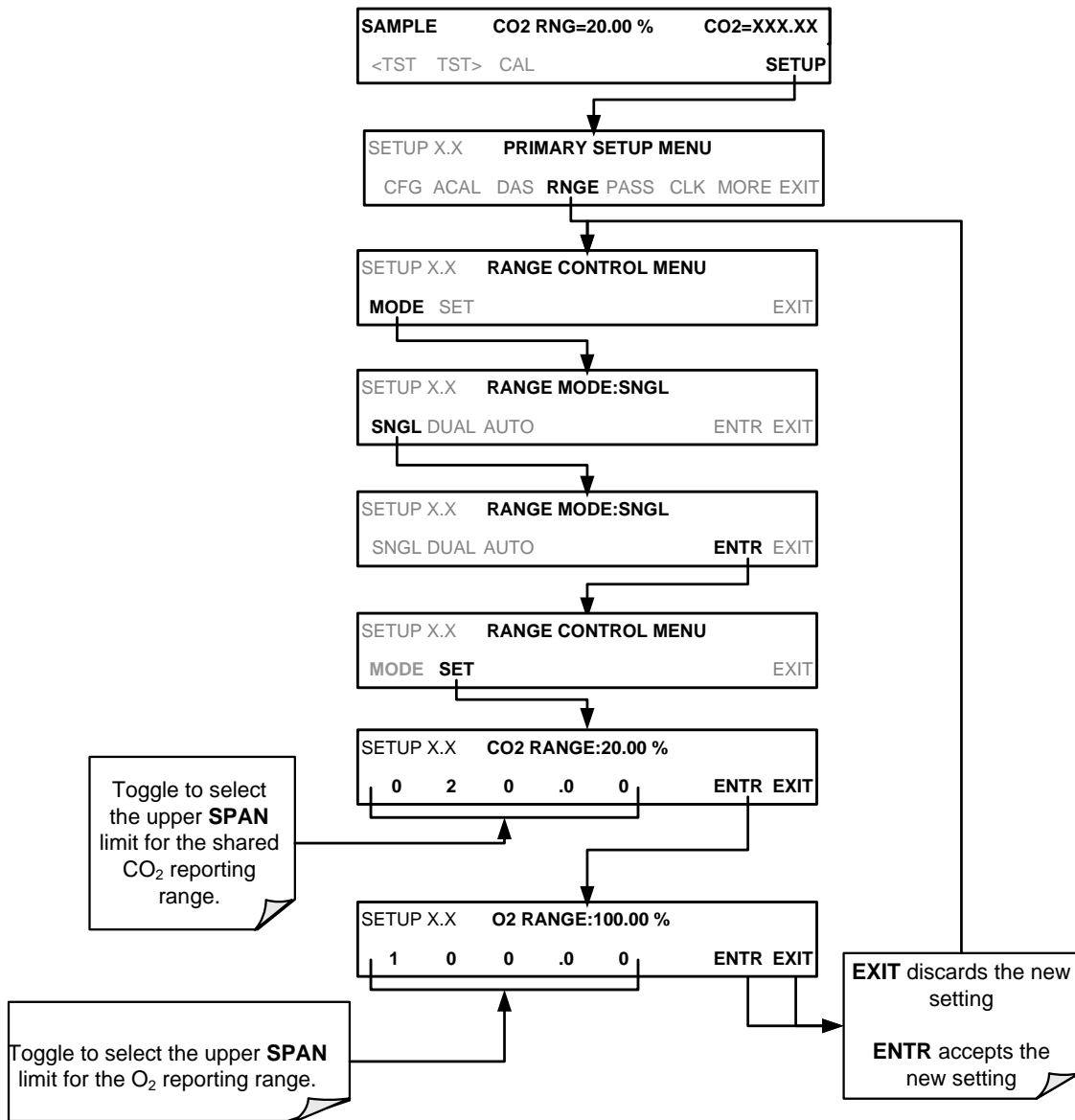

(The ACAL submenu in the Primary Setup Menu is a special configuration; consult factory).

5.4.3.2. RNGE → MODE → DUAL: CONFIGURING THE T803 ANALYZER FOR DUAL RANGE MODE

Selecting the **DUAL** range mode allows the **A1** and **A2** outputs to be configured with different reporting ranges. The analyzer software calls these two ranges RNG1 (low) and RNG2 (high).

- The **C2L RANGE 1** setting corresponds with the analog output labeled **A1** on the rear panel of the instrument.
- The **C2H RANGE 2** setting corresponds with the **A2** output.

In **DUAL** range mode the **RANGE** test function displayed on the front panel will be replaced by two separate functions:

- **CO2 RN1**: The range setting for the A1 output.
- **CO2 RN2**: The range setting for the A2 output.

To select the **DUAL** range mode press following touchscreen button sequence

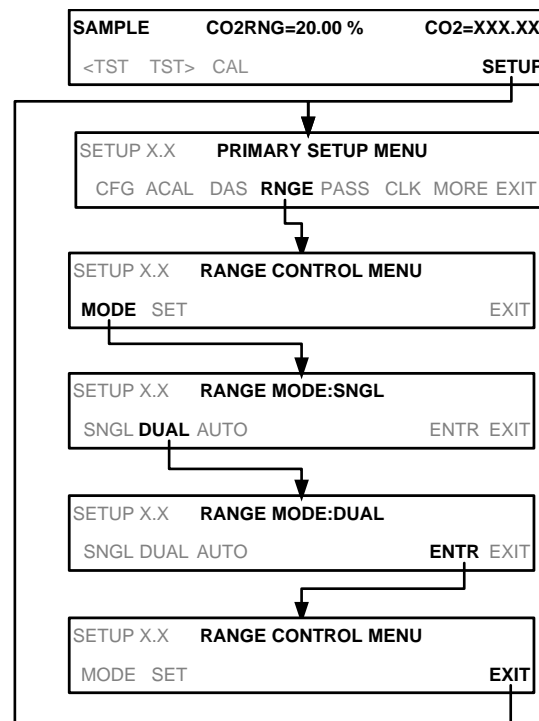

When the instrument's range mode is set to Dual the concentration field in the upper right hand corner of the display alternates between displaying the low range value and the high range value. The concentration that would be displayed, is identified as follows: "**C2L**" = **LOW** (or **A1**) and "**C2H**" = **HIGH** (or **A2**).

Note

In **DUAL** range mode **O2L** and **O2H** have separate slopes and offsets for computing **O₂** concentrations. The two ranges must be independently calibrated.

To set the upper range limit for each independent reporting range, press:

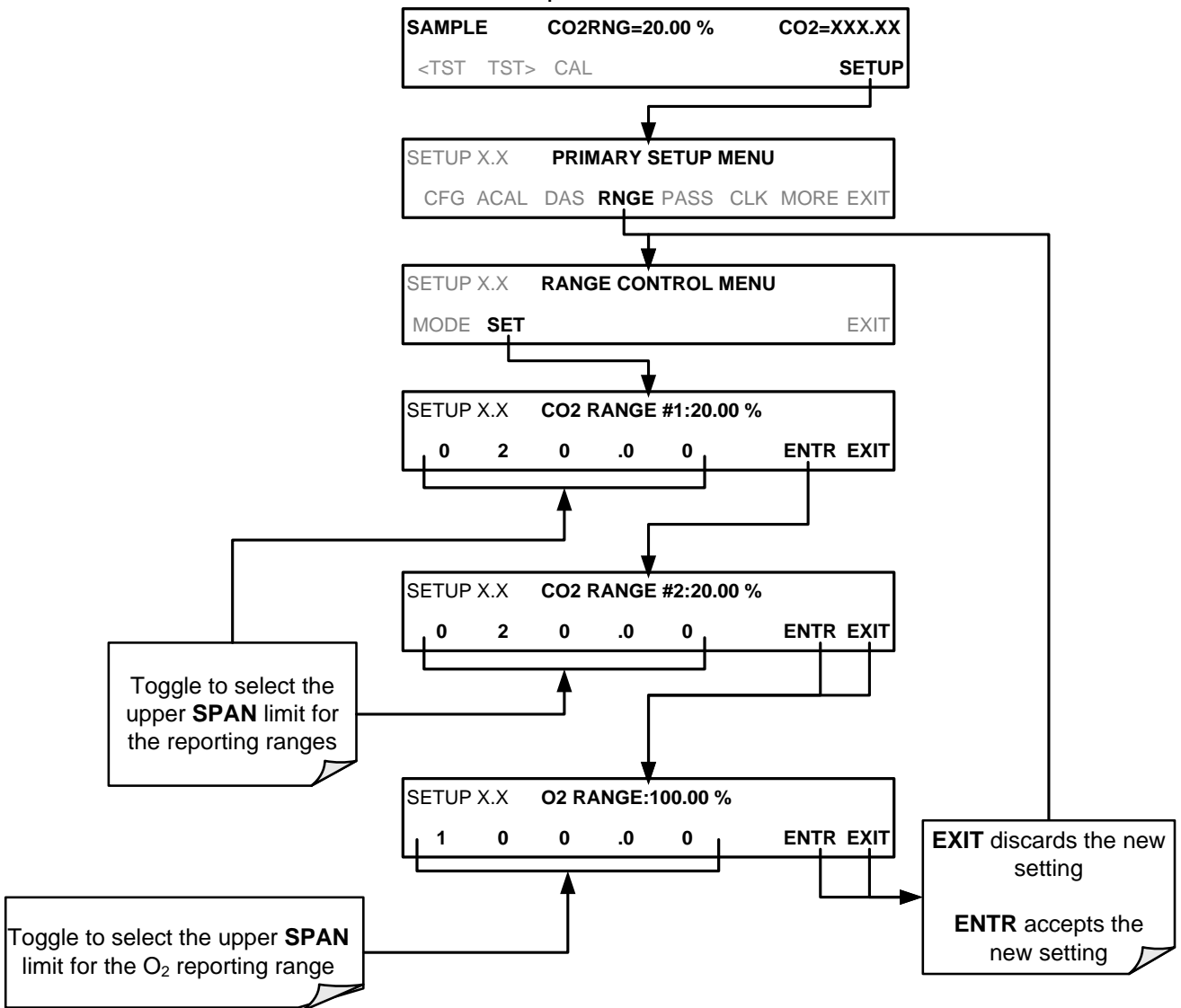

(The ACAL submenu in the Primary Setup Menu is a special configuration; consult factory).

5.4.3.3. **RNGE → MODE → AUTO: CONFIGURING THE T803 ANALYZER FOR AUTO RANGE MODE**

In **AUTO** range mode, the analyzer automatically switches the reporting range between two user-defined ranges (low and high).

- The unit will switch from low range to high range when the CO₂ concentration exceeds 98% of the low range span.
- The unit will return from high range back to low range once the CO₂ concentration falls below 75% of the low range span.

In **AUTO** Range mode the instrument reports the same data in the same range on both the **A1** and **A2** outputs and automatically switches both outputs between ranges as described above.

Also the **RANGE** test function displayed on the front panel will be replaced by two separate functions:

- **CO2 RNG1**: The **LOW** range setting for all analog outputs.
- **CO2 RNG2**: The **HIGH** range setting for all analog outputs.

The high/low range status is also reported through the external, digital status bits (See Section 3.3.1.4).

To set individual ranges press the following touchscreen button sequence:

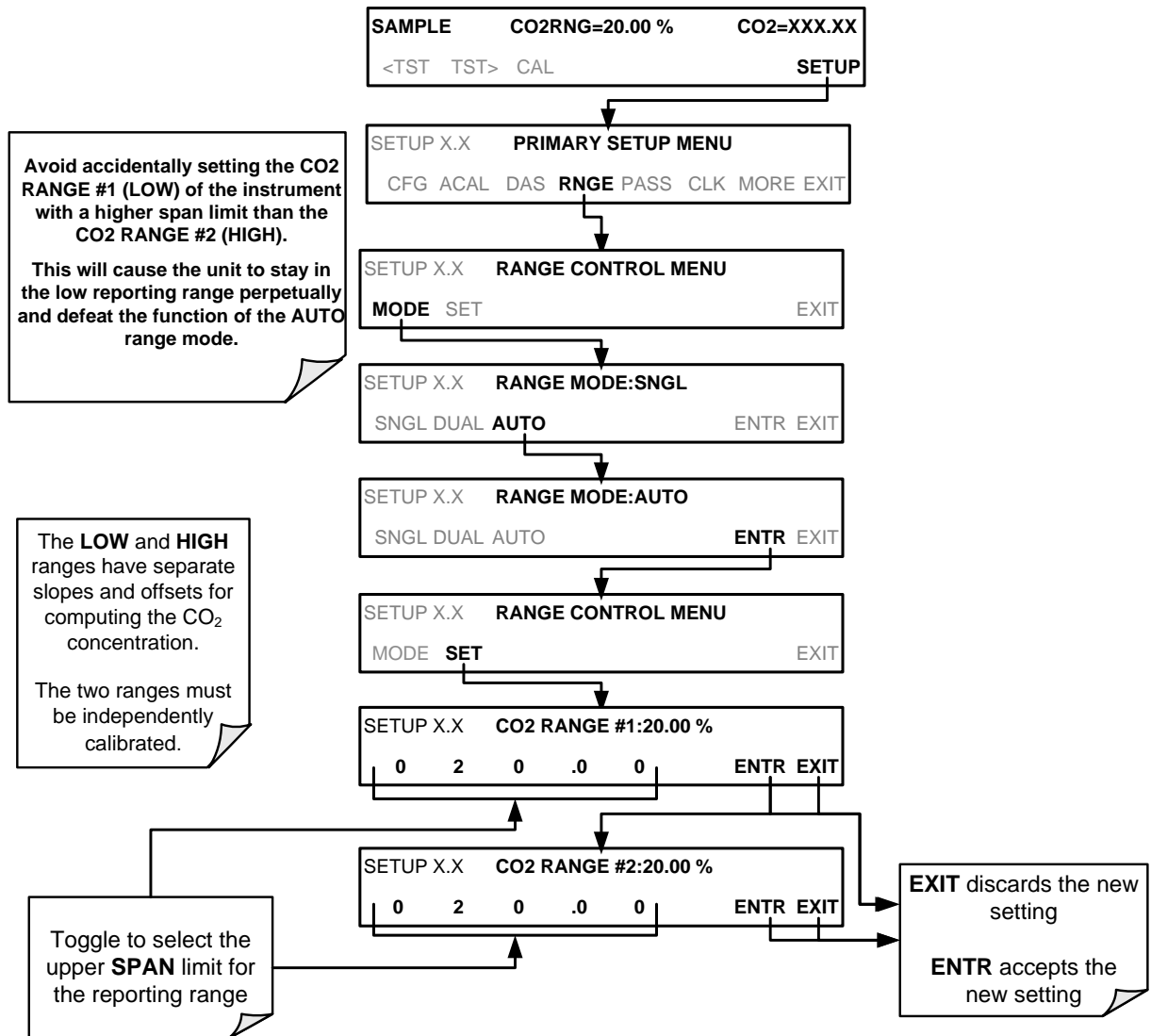

(The ACAL submenu in the Primary Setup Menu is a special configuration; consult factory).

5.4.4. SETUP → RNGE → DIL: USING THE OPTIONAL DILUTION RATIO FEATURE

This feature is an optional software utility that is used to compensate for any dilution of the sample gas that may occur before it enters the sample inlet. Typically this occurs in continuous emission monitoring (CEM) applications where the sampling method used to remove the gas from the stack, dilutes the sample.

Using the dilution ratio option is a 3-step process:

1. Select the reporting range mode and set the reporting range upper limit (see Section 5.4.3).

Ensure that the upper span limit entered for the reporting range is the maximum expected concentration of the non-diluted gas.

2. Set the dilution factor as a gain (e.g., a value of 20 means 20 parts diluent and 1 part of sample gas):

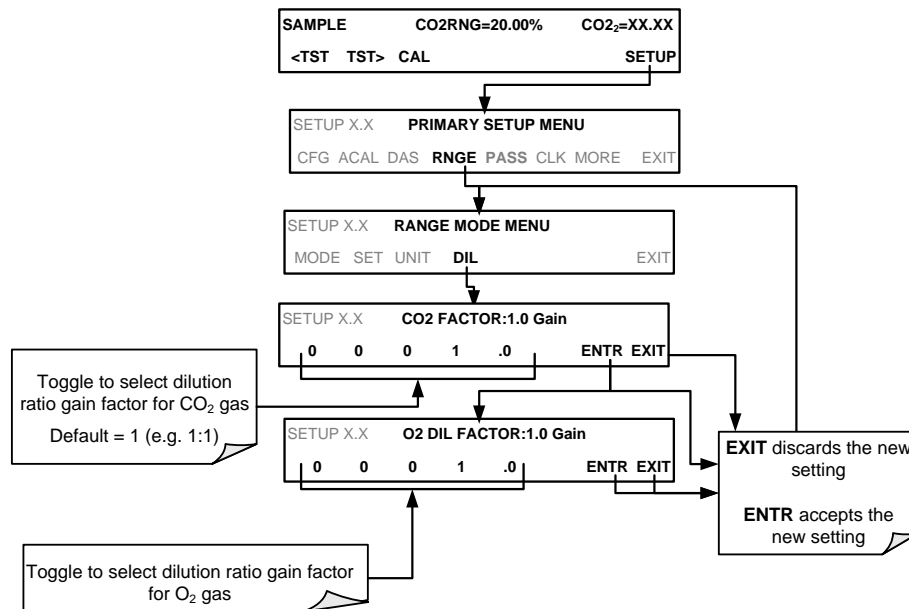

3. Calibrate the analyzer.

- Make sure that the calibration span gas is either supplied through the same dilution system as the sample gas or has an appropriately lower actual concentration.

EXAMPLE: If the reporting range limit is set for 100 % and the dilution ratio of the sample gas is 20, either:

- a span gas with the concentration of 100 % can be used if the span gas passes through the same dilution steps as the sample gas, or;
- a 5 % span gas must be used if the span gas **IS NOT** routed through the dilution system.

5.5. SETUP → PASS: PASSWORD FEATURE

The menu system provides password protection of the calibration and setup functions to prevent unauthorized adjustments. When the passwords have been enabled in the PASS menu item, the system will prompt the user for a password anytime a password-protected function (e.g., SETUP) is selected. This allows normal operation of the instrument, but requires the password (101) to access to the menus under SETUP. When PASSWORD is disabled (SETUP>PASS>OFF), any operator can enter the Primary Setup (SETUP) and Secondary Setup (SETUP>MORE) menus. Whether PASSWORD is enabled or disabled, a password (default 818) is required to enter the VARS or DIAG menus in the SETUP>MORE menu.

Table 5-6: Password Levels

PASSWORD	LEVEL	MENU ACCESS ALLOWED
Null (000)	Operation	All functions of the main menu (top level, or Primary, menu).
101	Configuration/Maintenance	Access to Primary and Secondary SETUP Menus when PASSWORD is enabled.
818	Configuration/Maintenance	Access to Secondary SETUP Submenus VARs and DIAG whether PASSWORD is enabled or disabled.

IMPORTANT

IMPACT ON READINGS OR DATA

There are more VARs available when using the password, 929, for configuration. Use caution when pressing any buttons while in this setup. Any changes made may alter the performance of the instrument or cause the instrument to not function properly. To discard an accidental change to a setup parameter, press EXIT.

To enable or disable passwords, press:

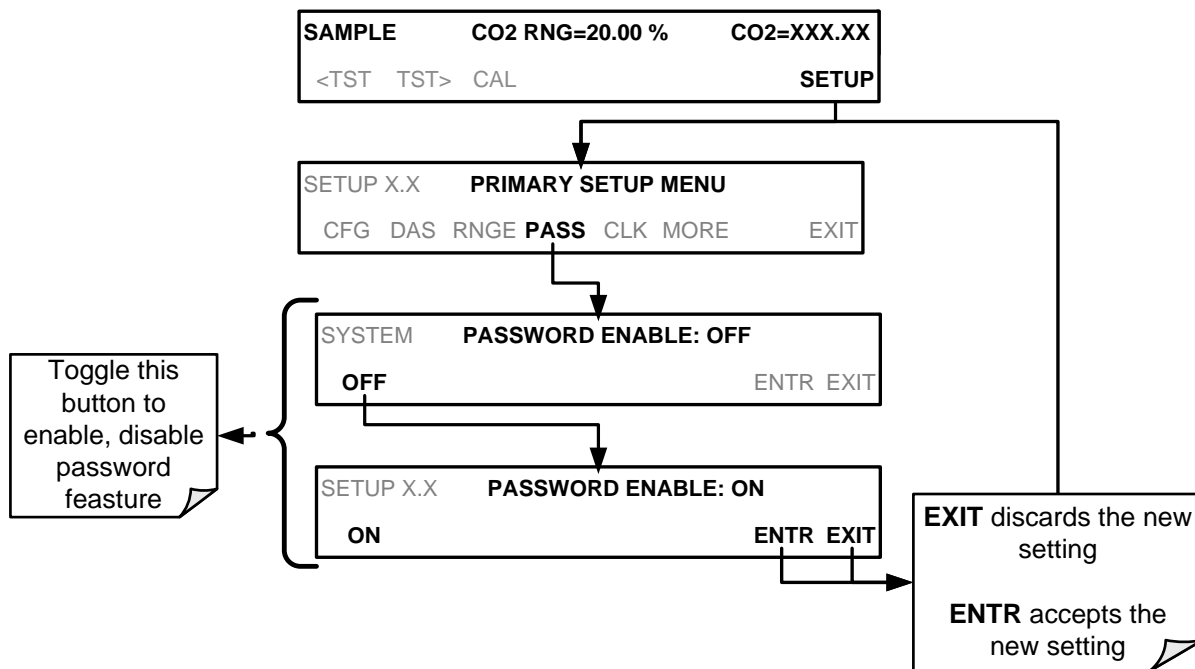

Example: If all passwords are enabled, the following touchscreen button sequence would be required to enter the **SETUP** menu:

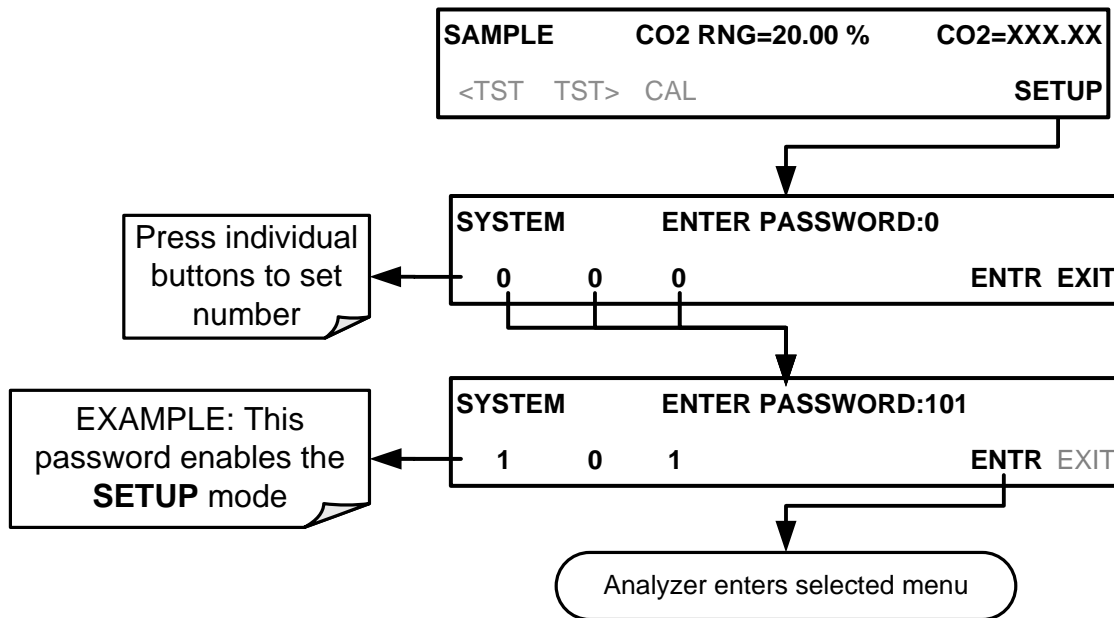

Note

When **PASSWORD ENABLE** is set to **OFF**, the instrument still prompts for a password when entering the **VAR**s and **DIAG** menus, but it displays the default password (818). Press **ENTR** to continue.

5.6. SETUP → CLK: SETTING THE T803 ANALYZER'S INTERNAL CLOCK

5.6.1. SETTING THE INTERNAL CLOCK'S TIME AND DAY

The T803 has a time of day clock that supports the time of day TEST function, the time stamps for the DAS feature and most COM port messages.

To set the clock's time and day, press:

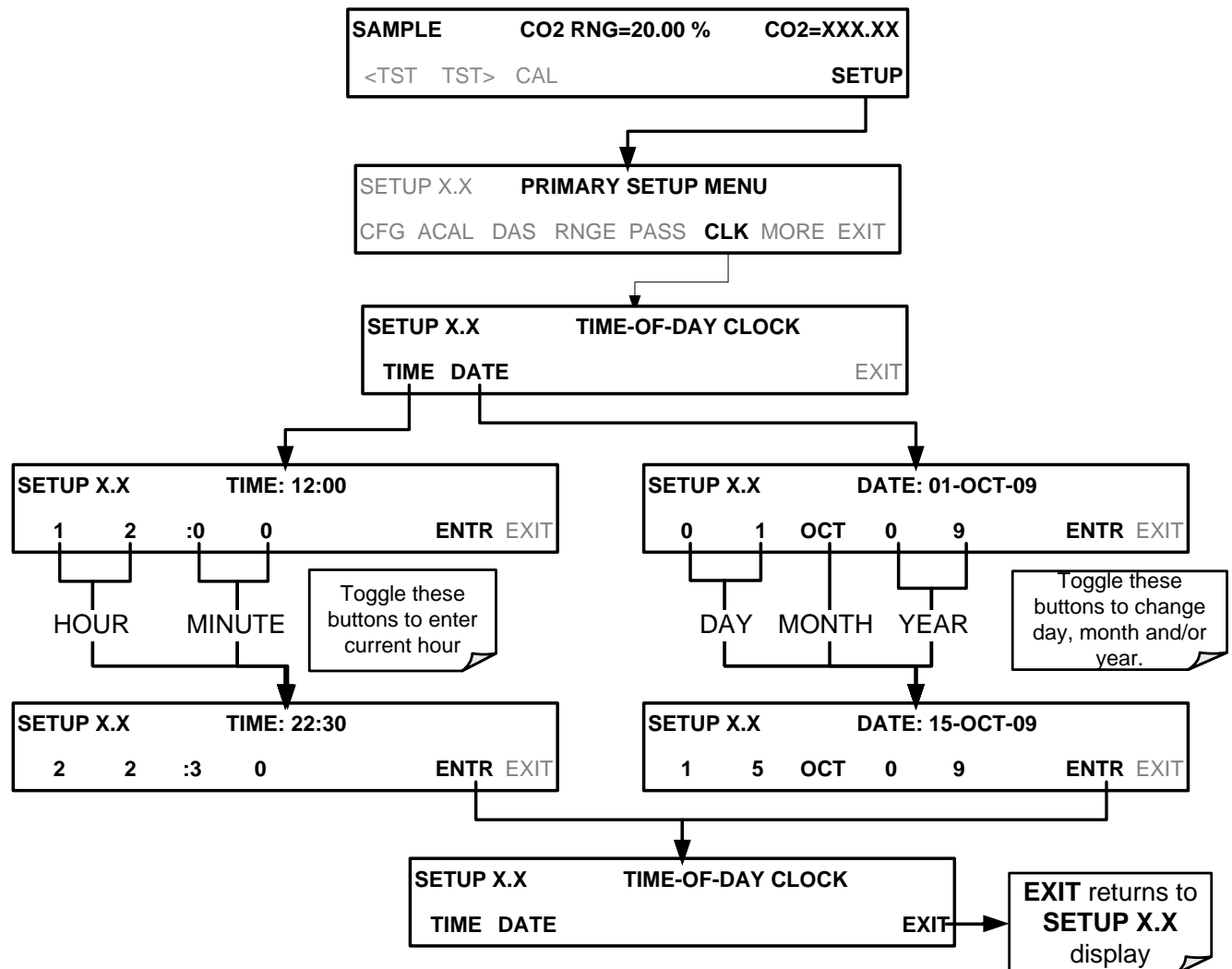

(The ACAL submenu in the Primary Setup Menu is a special configuration; consult factory).

5.6.2. ADJUSTING THE INTERNAL CLOCK'S SPEED

In order to compensate for CPU clocks that run faster or slower, you can adjust a variable called **CLOCK_ADJ** to speed up or slow down the clock by a fixed amount every day.

The **CLOCK_ADJUST** variable is accessed via the **VARS** submenu: To change the value of this variable, press:

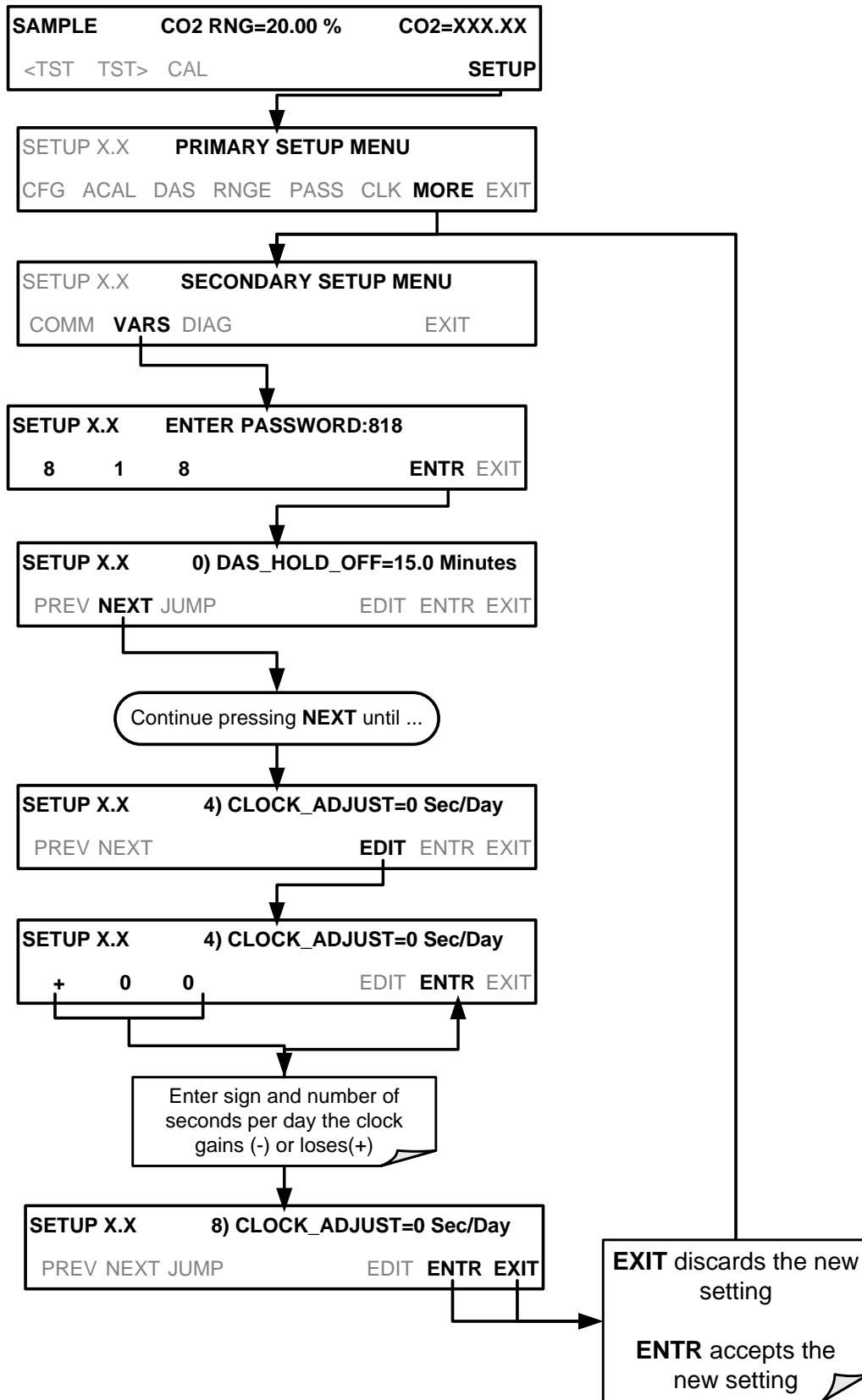

(The ACAL submenu in the Primary Setup Menu is a special configuration; consult factory).

5.7. **SETUP → MORE → COMM**

The communications setup menu is for setting up serial and Ethernet communications for remote operation; it includes changing the ID of the instrument when more than one analyzer of the same model is connected to the same communications channel, e.g., same Ethernet LAN, RS-232 multidrop chain, or when applying MODBUS or HESSEN protocols.

5.8. **SETUP → MORE → VARS: INTERNAL VARIABLES (VARS)**

The T803 has several user-adjustable software variables, which define certain operational parameters. Usually, these variables are automatically set by the instrument's firmware, but can be manually redefined through the **VARS** menu.

The following table lists all variables that are available within the 818 password protected level. See Appendix A2 for a detailed listing of all of the T803 variables that are accessible through the remote interface.

Table 5-1: Variable Names (VARS)

NO.	VARIABLE	DESCRIPTION	ALLOWED SETTINGS	VARS DEFAULT SETTINGS
0	DAS_HOLD_OFF	Changes the Internal Data Acquisition System (DAS) HOLD OFF timer: No data are stored in the DAS channels during situations when the software considers the data to be questionable such as during warm up or just after the instrument returns from one of its calibration modes to SAMPLE Mode.	May be set for intervals between 0.5 – 20 min	15 min.
1	STABIL_GAS	Selects which gas measurement is displayed when the STABIL test function is selected.	CO ₂ ; O ₂	CO2
2	TPC_ENABLE	NOTE: It is strongly recommended that this variable NOT be changed. ON enables, OFF disables temperature and pressure compensation	ON, OFF	ON
3	DYN_ZERO Special configuration; consult factory	[Automatically adjusts offset and slope of the O ₂ response when performing a zero point calibration during an AutoCal.]	[ON, OFF]	[OFF]
4	DYN_SPAN Special configuration; consult factory	[Automatically adjusts offset and slope of the O ₂ response when performing a zero point calibration during an AutoCal.]	[ON, OFF]	[OFF]
5	CONC_PRECISION	Allows the user to set the number of significant digits to the right of the decimal point display of concentration and stability values.	AUTO, 1, 2, 3, 4	AUTO
6	CLOCK_ADJ	Adjusts the speed of the analyzer's clock. Choose the + sign if the clock is too slow, choose the - sign if the clock is too fast. Toggle buttons to change the number of seconds.	-60 to +60 s/day	0 Sec/Day
7	SERVICE_CLEAR	Pressing the OFF button to display SERVICE_CLEAR:ON, followed by pressing ENTR resets the service interval timer and returns this Var back to its default setting, ready for the next reset.	ON, OFF	OFF
8	TIME_SINCE_SVC	Displays time in hours since last service (restarted by the SERVICE_CLEAR Variable).	0-50,000	0
9	SVC_INTERVAL	Sets the interval in hours between service reminders.	0-100,000	0

To access and navigate the **VARS** menu, use the following button sequence.

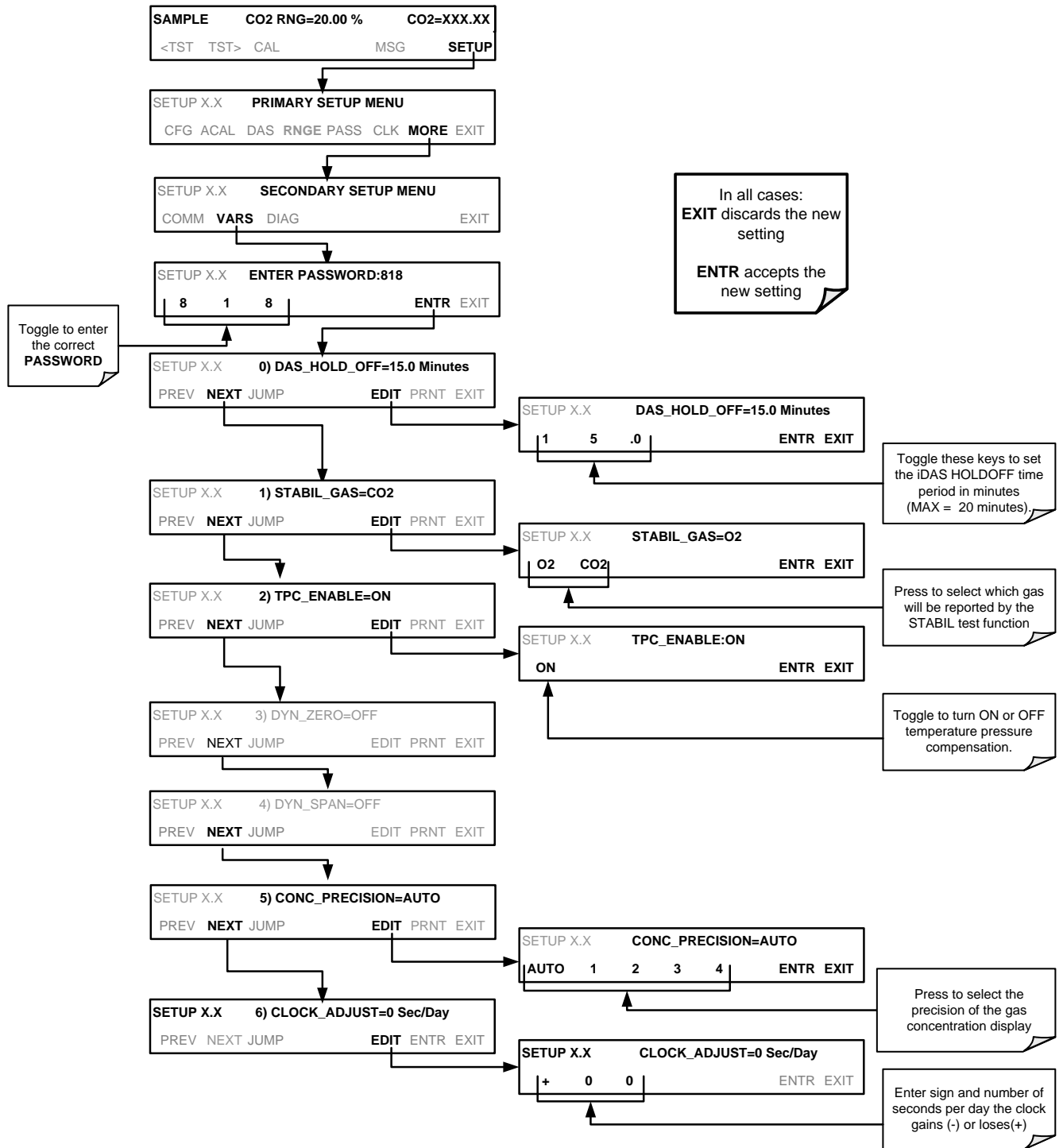

5.9. SETUP → MORE → DIAG: USING THE DIAGNOSTICS FUNCTIONS

A series of diagnostic tools is grouped together under the **SETUP→MORE→DIAG** menu. These tools can be used in a variety of troubleshooting and diagnostic procedures and are referred to in many places of the maintenance and trouble-shooting sections of this manual.

The various operating modes available under the **DIAG** menu are:

Table 5-2: Diagnostic Mode (DIAG) Functions

DIAG SUBMENU	SUBMENU FUNCTION	Front Panel Mode Indicator	MANUAL SECTION
SIGNAL I/O	Allows observation of all digital and analog signals in the instrument. Allows certain digital signals such as heaters to be toggled ON and OFF . These parameters are dependent on firmware revision, (see Appendix A).	DIAG I/O	11.1.3
ANALOG OUTPUT	When entered, the analyzer performs an analog output step test. This can be used to calibrate a chart recorder or to test the analog output accuracy.	DIAG AOUT	11.6.9.2
ANALOG I/O CONFIGURATION	This submenu allows the user to configure the analyzer's analog output channels, including choosing what parameter will be output on each channel. Instructions that appear here allow adjustment and calibration of the voltage signals associated with each output as well as calibration of the analog to digital converter circuitry on the motherboard.	DIAG AIO	5.10.1
PRESSURE CALIBRATION¹	This function is used to calibrate the Sample Pressure sensor.	DIAG PCAL	9.4.1
FLOW CALIBRATION¹	This function is used to calibrate the sample gas flow.	DIAG FCAL	9.4.2
TEST CHAN OUTPUT	Selects one of the available test channel signals to output over the A4 analog output channel.	DIAG TCHN	5.10.6

¹ These settings are retained after exiting DIAG mode.

5.9.1. ACCESSING THE DIAGNOSTIC FEATURES

To access the **DIAG** functions press the following buttons:

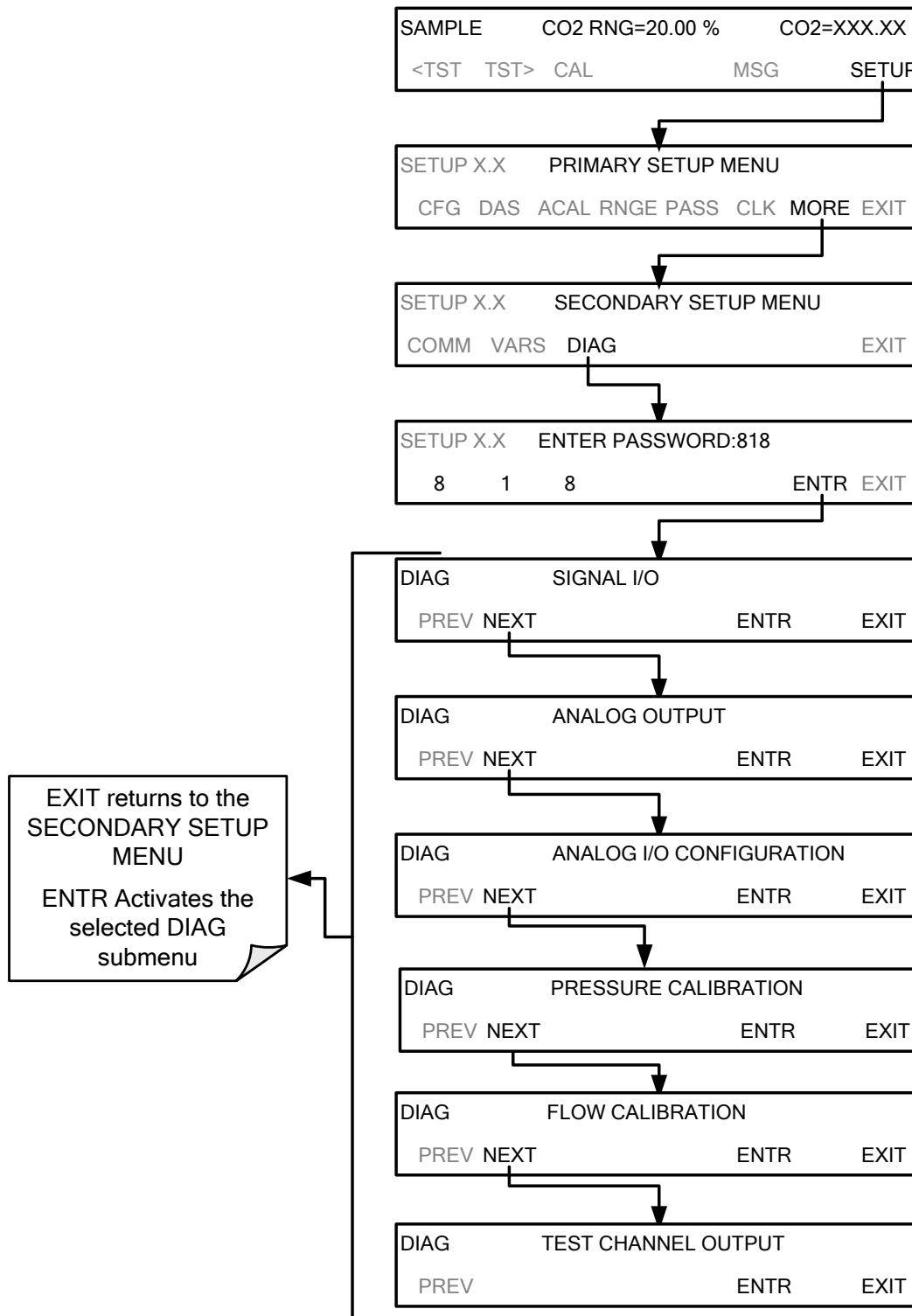

(The ACAL submenu in the Primary Setup Menu is a special configuration; consult factory).

5.10. USING THE T803 ANALYZER'S ANALOG OUTPUTS

The T803 analyzer comes equipped with four analog outputs.

- The first two analog output (**A1 & A2**) signals represent the currently measured CO₂ concentration (see Section 5.4.2).
- The third analog output (**A3**) measures the current O₂ concentration.
- The fourth output (**A4**) outputs a signal that can be set to represent the current value of one of several test functions (see Table 5-7).

5.10.1. ACCESSING THE ANALOG OUTPUT SIGNAL CONFIGURATION SUBMENU

The following lists the analog I/O functions that are available in the T803 analyzer.

Table 5-3: DIAG - Analog I/O Functions

SUB MENU	FUNCTION
AOUT CALIBRATED	Initiates a calibration of the A1 , A2 , A3 and A4 analog output channels that determines the slope and offset inherent in the circuitry of each output. These values are stored in the memory and applied to the output signals by the CPU automatically.
CONC_OUT_1	Sets the basic electronic configuration of the A1 output (CO ₂ Concentration). There are four options: <ul style="list-style-type: none"> • RANGE¹: Selects the signal type (voltage or current loop) and level of the output • REC OFS: Allows them input of a DC offset to let the user manually adjust the output level • AUTO CAL: Enables / Disables the AOUT CALIBRATION Feature • CALIBRATED: Performs the same calibration as AOUT CALIBRATED, but on this one channel only.
CONC_OUT_2	• Same as for CONC_OUT_1 but for analog channel A2 and only if Auto or Dual range is selected (CO ₂ high range, RNG2)
CONC_OUT_3	• Same as for CONC_OUT_1 but for analog channel A3 but only for the O ₂ sensor.
TEST OUTPUT	• Same as for CONC_OUT_1 but for analog channel A4 (TEST CHANNEL)
AIN CALIBRATED	Initiates a calibration of the A-to-D Converter circuit located on the Motherboard.
XIN1 . . . XIN8	For each of 8 external analog inputs channels, shows the gain, offset, engineering units, and whether the channel is to show up as a Test function.
¹ Any changes made to RANGE or REC_OFS require recalibration of this output.	

To access the **ANALOG I/O CONFIGURATION** sub menu, press:

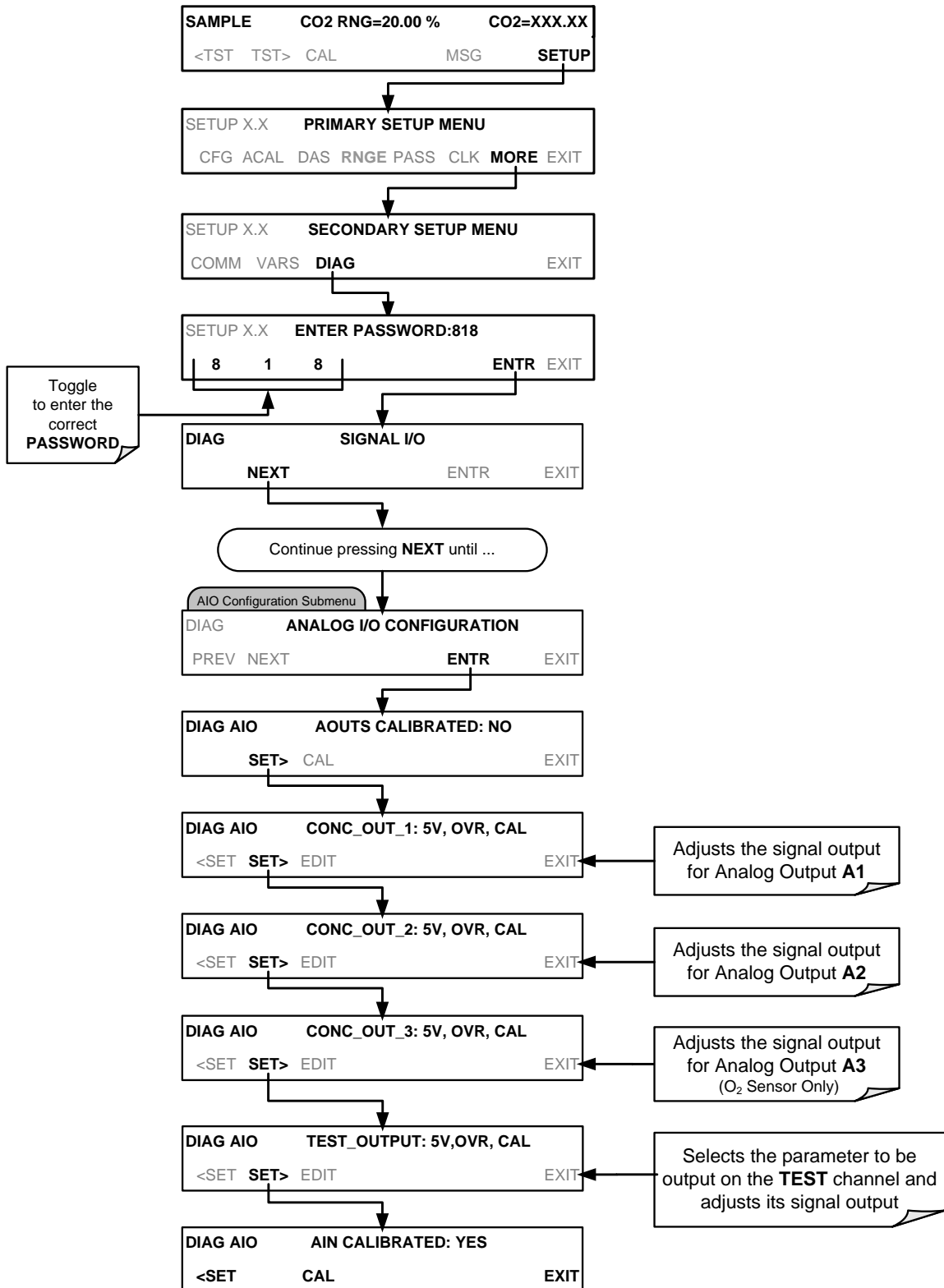

(The ACAL submenu in the Primary Setup Menu is a special configuration; consult factory).

5.10.2. ANALOG OUTPUT VOLTAGE / CURRENT RANGE SELECTION

In its standard configuration the analog outputs are set to output a 0 – 5 VDC signals. Several other output ranges are available. Each range is usable from -5% to +5% of the rated span.

Table 5-4: Analog Output Voltage Range Min/Max

RANGE NAME	RANGE SPAN	MINIMUM OUTPUT	MAXIMUM OUTPUT
0.1V	0-100 mVDC	-5 mVDC	105 mVDC
1V	0-1 VDC	-0.05 VDC	1.05 VDC
5V	0-5 VDC	-0.25 VDC	5.25 VDC
10V	0-10 VDC	-0.5 VDC	10.5 VDC
<ul style="list-style-type: none"> The default offset for all VDC ranges is 0-5 VDC. 			
CURR	0-20 mA	0 mA	20 mA
<ul style="list-style-type: none"> While these are the physical limits of the current loop modules, typical applications use 2-20 or 4-20 mA for the lower and upper limits. Please specify desired range when ordering this option. The default offset for all current ranges is 0 mA. 			

To change the output type and range, select the **ANALOG I/O CONFIGURATION** submenu (see Section 5.10.1) then press,

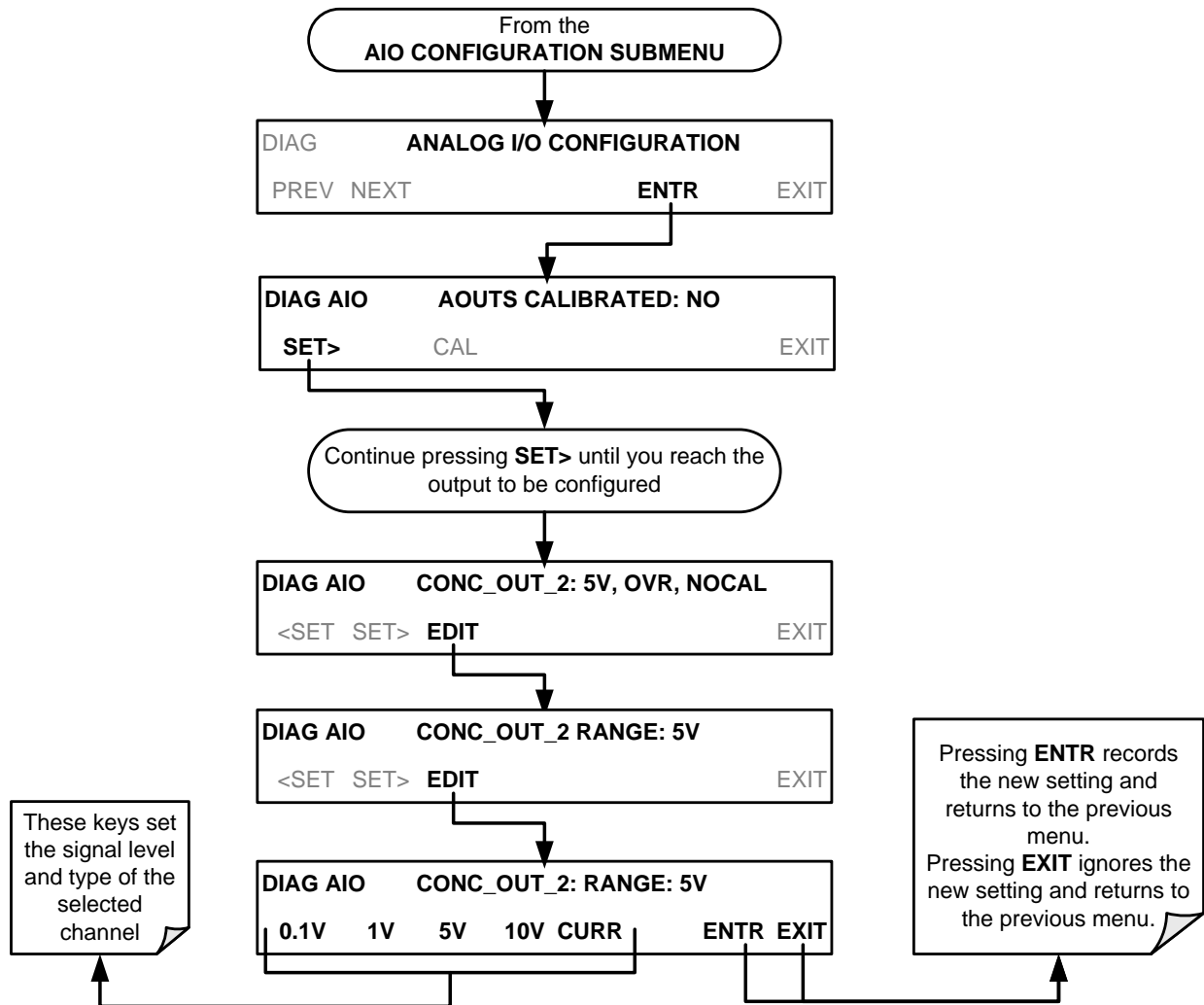

5.10.3. CALIBRATION OF THE ANALOG OUTPUTS

Analog output calibration should be carried out on first startup of the analyzer (performed in the factory as part of the configuration process) or whenever recalibration is required. The analog outputs can be calibrated automatically, either as a group or individually, or adjusted manually.

In its default mode, the instrument is configured for automatic calibration of all channels, which is useful for clearing any analog calibration warnings associated with channels that will not be used or connected to any input or recording device, e.g., datalogger.

Manual calibration should be used for the 0.1V range or in cases where the outputs must be closely matched to the characteristics of the recording device. Manual calibration requires the AUTO CAL feature to be disabled.

5.10.3.1. ENABLING OR DISABLING THE AUTOCAL FOR AN INDIVIDUAL ANALOG OUTPUT

To enable or disable the **AutoCal** feature for an individual analog output, elect the **ANALOG I/O CONFIGURATION** submenu (see Section 5.10.1) then press:

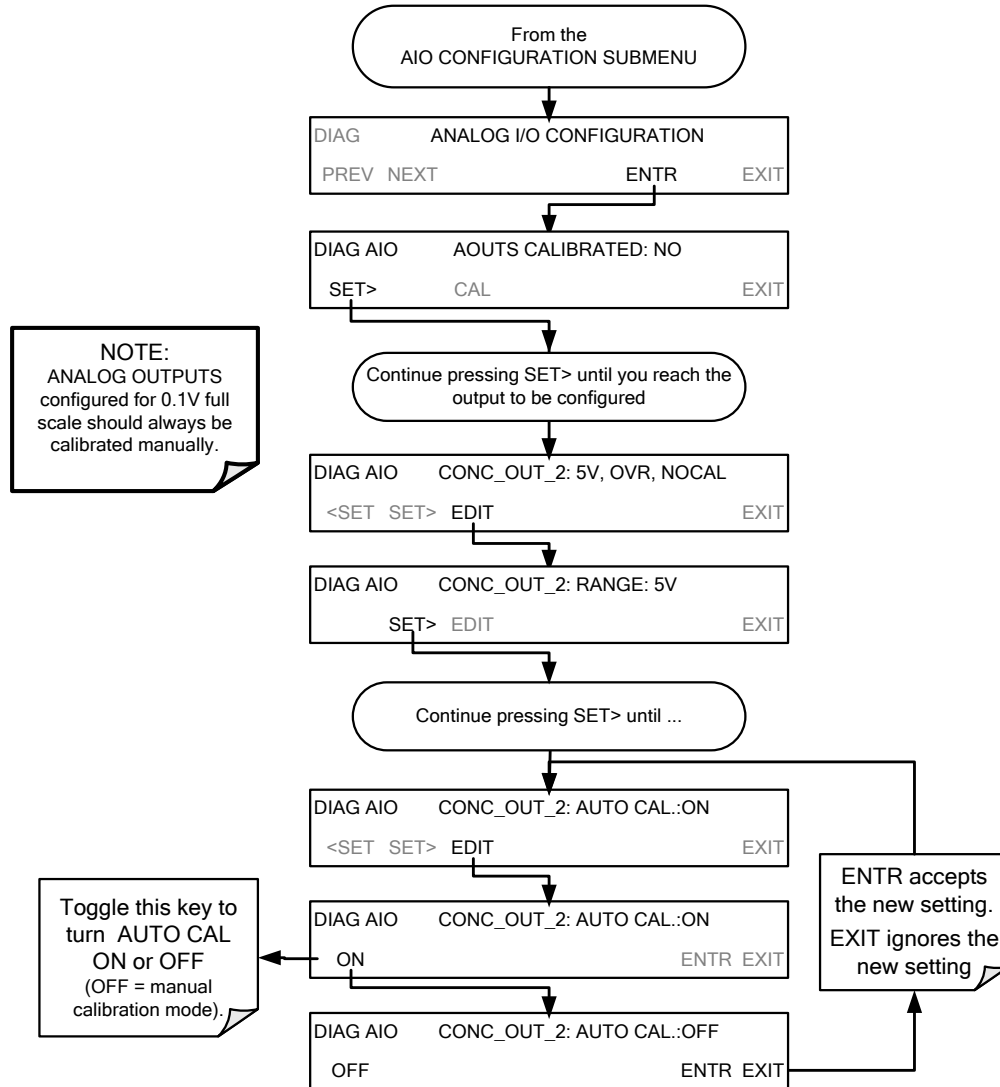

5.10.3.2. AUTOMATIC CALIBRATION OF THE ANALOG OUTPUTS

IMPORTANT

IMPACT ON READINGS OR DATA

Manual calibration should be used for any analog output set for a 0.1V output range or in cases where the outputs must be closely matched to the characteristics of the recording device.

Before performing this procedure, ensure that the AUTO CAL for each analog output is enabled. (See Section 5.10.3.1)).

To calibrate the outputs as a group with the AOUTS CALIBRATION command, select the ANALOG I/O CONFIGURATION submenu (see Section 5.10.1) then press:

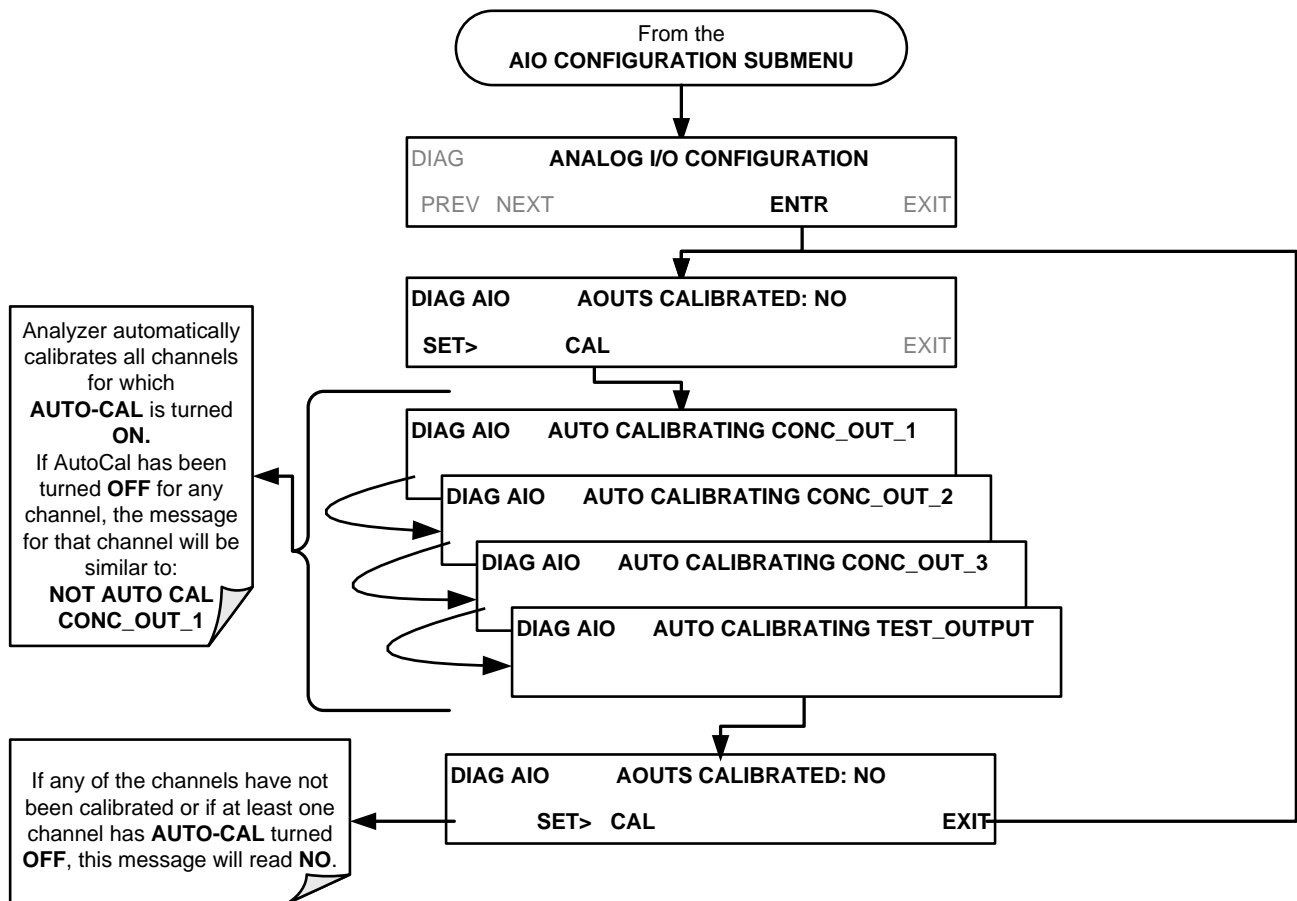

5.10.3.3. INDIVIDUAL (SINGLE-CHANNEL) CALIBRATION OF THE ANALOG OUTPUTS

To use the **AUTO CAL** feature to initiate an automatic calibration for an individual analog output, select the **ANALOG I/O CONFIGURATION** submenu (see Section 5.10.1) then press:

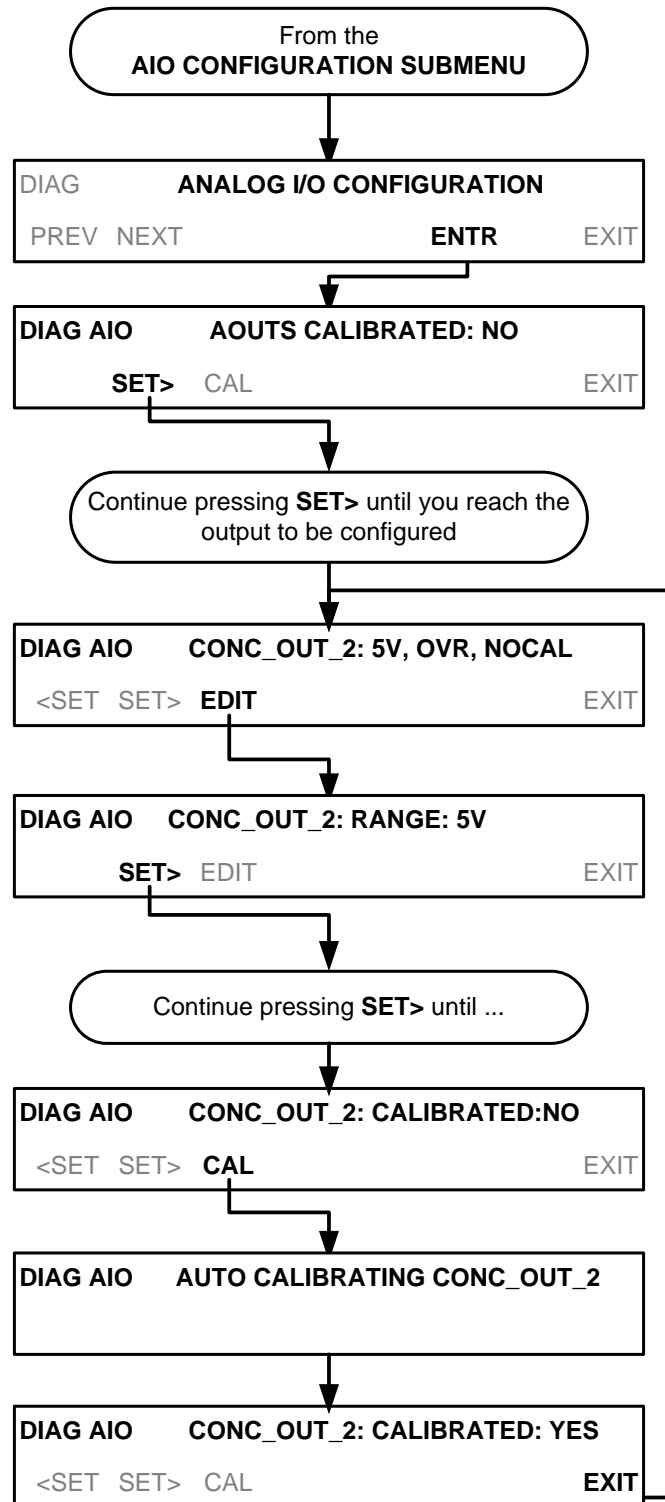

5.10.3.4. MANUAL CALIBRATION OF THE ANALOG OUTPUTS CONFIGURED FOR VOLTAGE RANGES

For highest accuracy, the voltages of the analog outputs can be manually calibrated.

Note

The menu for manually adjusting the analog output signal level will only appear if the AUTO-CAL feature is turned off for the channel being adjusted (See Section 5.10.3.1)).

Calibration is performed with a voltmeter connected across the output terminals and by changing the actual output signal level using the front panel buttons in 100, 10 or 1 count increments. See Figure 3-7 for pin assignments and diagram of the analog output connector.

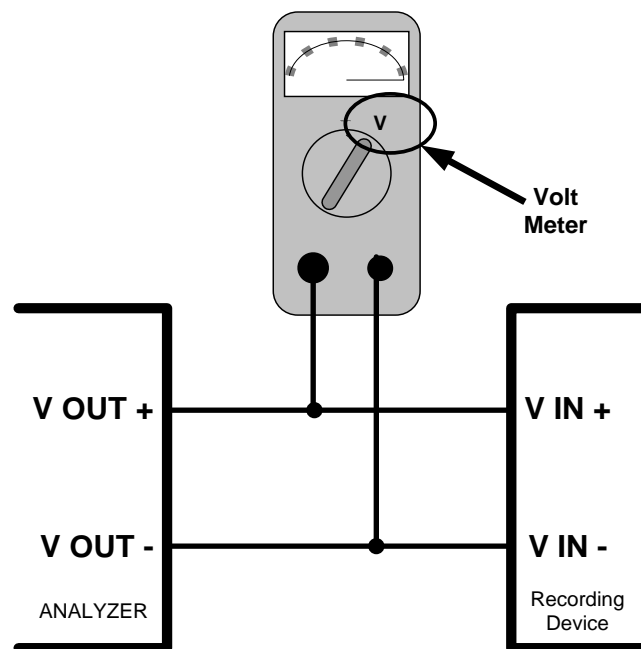
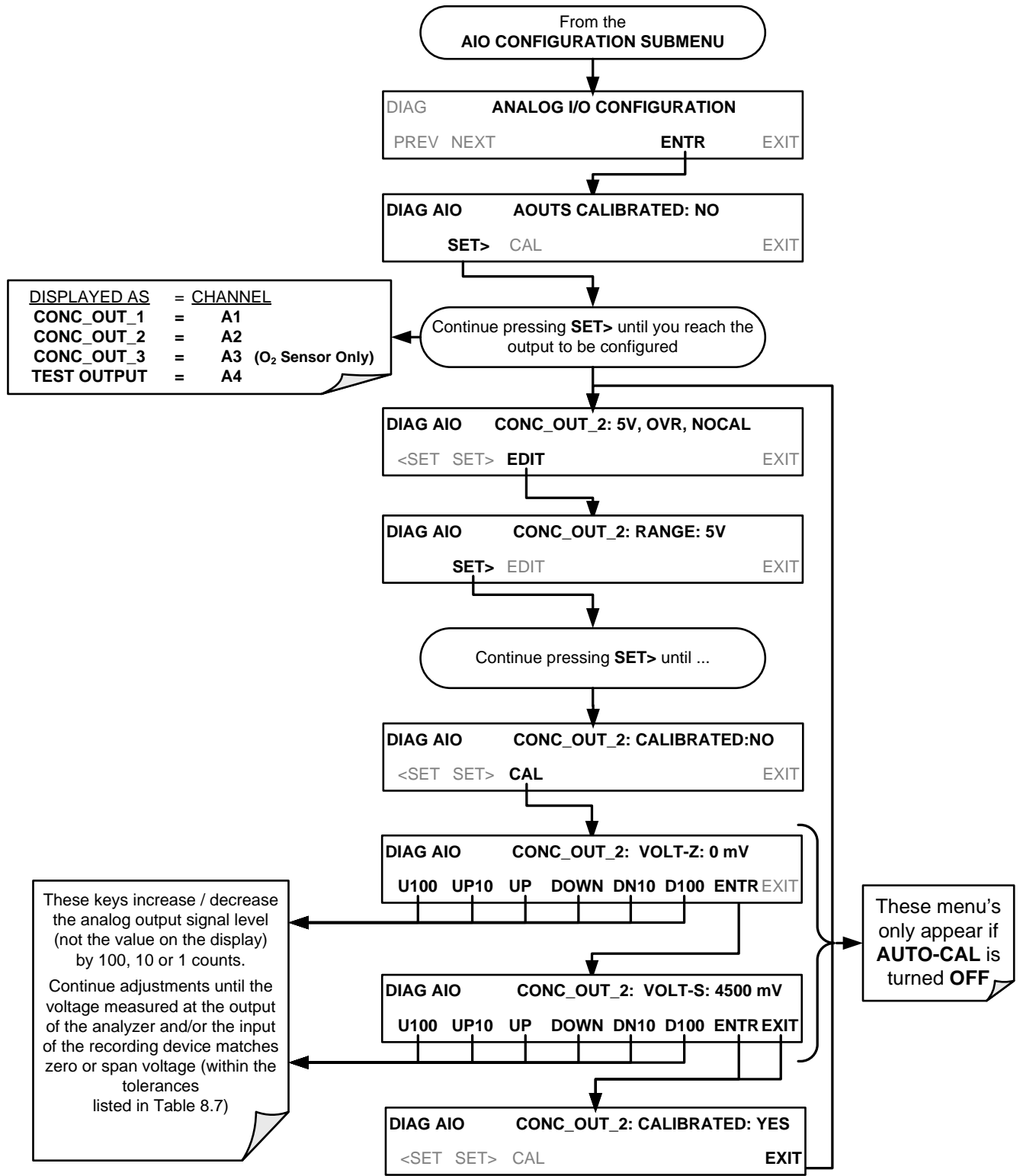

Figure 5-2: Setup for Checking / Calibrating DCV Analog Output Signal Levels

Table 5-5: Voltage Tolerances for the TEST CHANNEL Calibration

FULL SCALE	ZERO TOLERANCE	SPAN VOLTAGE	SPAN TOLERANCE	MINIMUM ADJUSTMENT (1 count)
0.1 VDC	±0.0005V	90 mV	±0.001V	0.02 mV
1 VDC	±0.001V	900 mV	±0.001V	0.24 mV
5 VDC	±0.002V	4500 mV	±0.003V	1.22 mV
10 VDC	±0.004V	4500 mV	±0.006V	2.44 mV

To adjust the signal levels of an analog output channel manually, select the **ANALOG I/O CONFIGURATION** submenu (see Section 5.10.1) then press:



5.10.3.5. MANUALLY ADJUSTING CURRENT LOOP OPTION OUTPUT SPAN AND OFFSET

A current loop option may be purchased for the **A1**, **A2** and **A3** analog outputs of the analyzer. This option places circuitry in series with the output of the A-to-D converter on the motherboard that changes the normal DC voltage output to a 0-20 milliamp signal (See Section 3.3.1.4).

- The outputs can be ordered scaled to any set of limits within that 0-20 mA range, however most current loop applications call for either 0-20 mA or 4-20 mA range spans.
- All current loop outputs have a + 5% over range. Ranges whose lower limit is set above 1 mA also have a 5% under range.

To switch an analog output from voltage to current loop, follow the instructions in Section 5.10.2 (select **CURR** from the list of options on the “Output Range” menu).

Adjustment of the signal zero and span levels of the current loop output is done by raising or lowering the voltage output of the D-to-A converter circuitry on the analyzer’s motherboard. This raises or lowers the signal level produced by the current loop option circuitry.

The software allows this adjustment to be made in 100, 10 or 1 count increments. Since the exact amount by which the current signal is changed per D-to-A count varies from output-to-output and instrument-to-instrument, you will need to measure the change in the signal levels with a separate, current meter placed in series with the output circuit. See Figure 3-7 for pin assignments and diagram of the analog output connector.

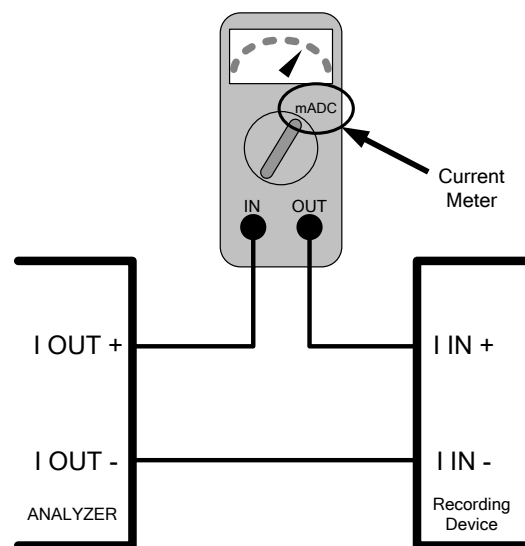

Figure 5-3: Setup for Checking / Calibration Current Output Signal Levels Using an Ammeter



CAUTION - GENERAL SAFETY HAZARD

Do not exceed 60 V peak voltage between current loop outputs and instrument ground.

To adjust the zero and span signal levels of the current outputs, select the **ANALOG I/O CONFIGURATION** submenu (see Section 5.10.1) then press:

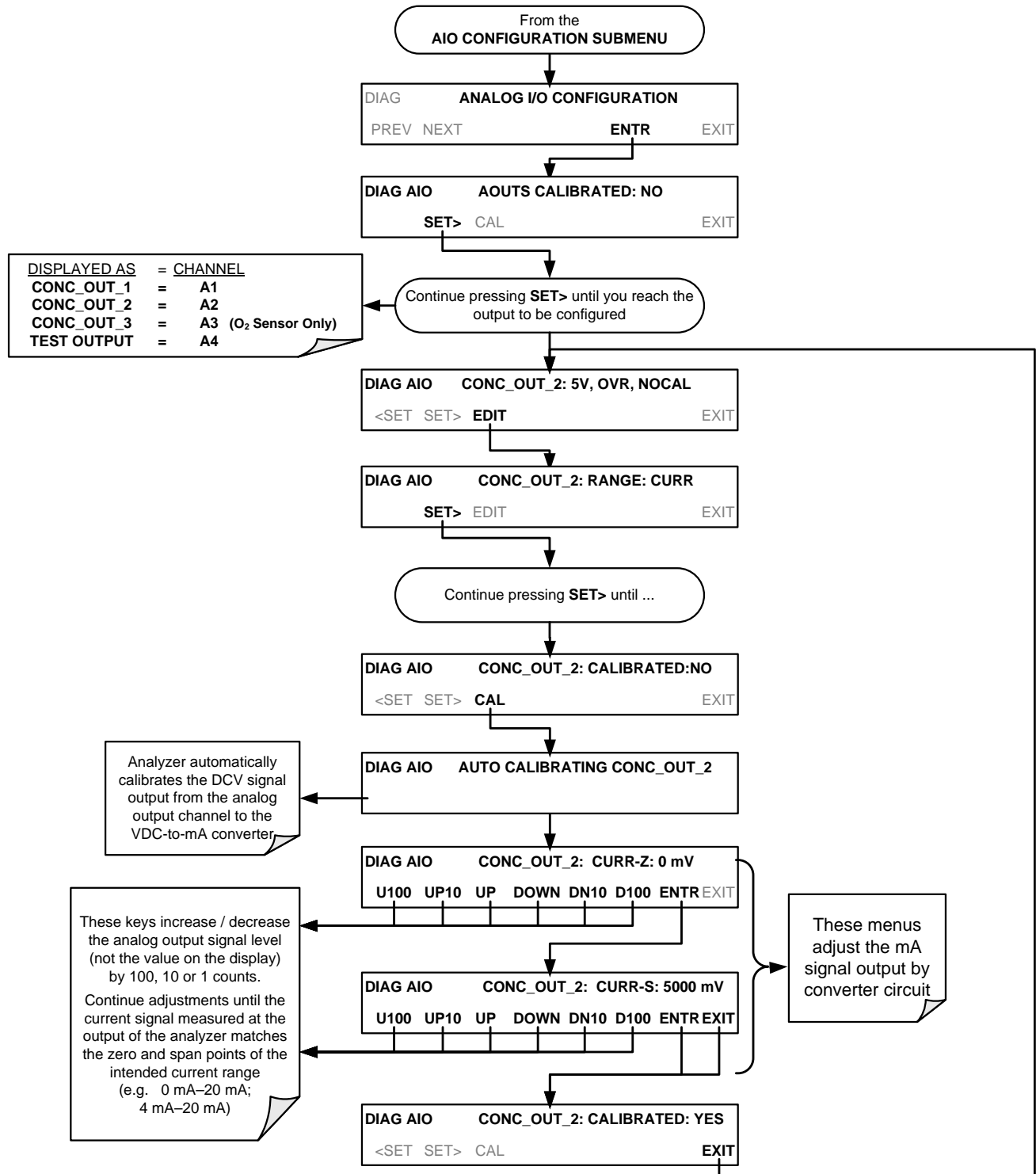

An alternative method for measuring the output of the Current Loop converter is to connect a 250 ohm ±1% resistor across the current loop output in lieu of the

current meter (see Figure 3-7 for pin assignments and diagram of the analog output connector). This allows the use of a voltmeter connected across the resistor to measure converter output as VDC or mVDC.

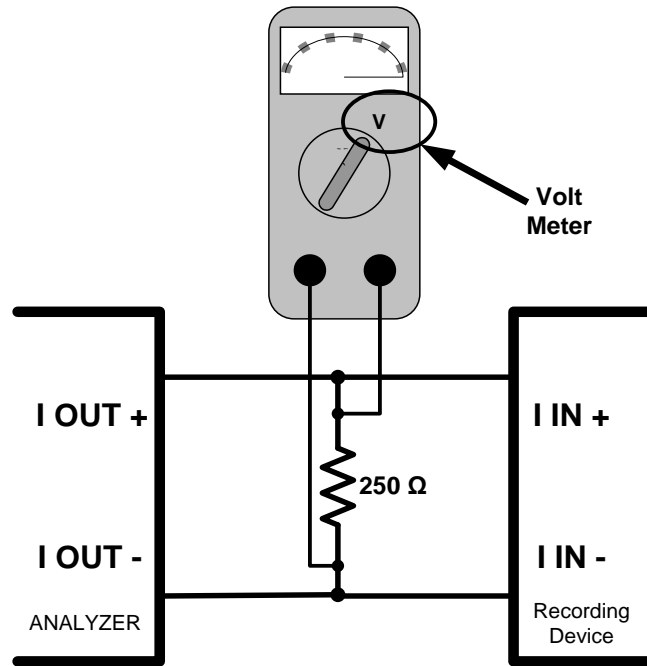

Figure 5-4: Alternative Setup Using 250Ω Resistor for Checking Current Output Signal Levels

In this case, follow the procedure above but adjust the output for the following values:

Table 5-6: Current Loop Output Check

% FS	Voltage across Resistor for 2-20 mA	Voltage across Resistor for 4-20 mA
0	500 mVDC	1000 mVDC
100	5000 mVDC	5000 mVDC

5.10.4. TURNING AN ANALOG OUTPUT OVER-RANGE FEATURE ON/OFF

In its default configuration, a $\pm 5\%$ over-range is available on each of the T803's analog outputs. This over-range can be disabled if your recording device is sensitive to excess voltage or current.

To turn the over-range feature on or off, select the **ANALOG I/O CONFIGURATION** submenu (see Section 5.10.1) then press

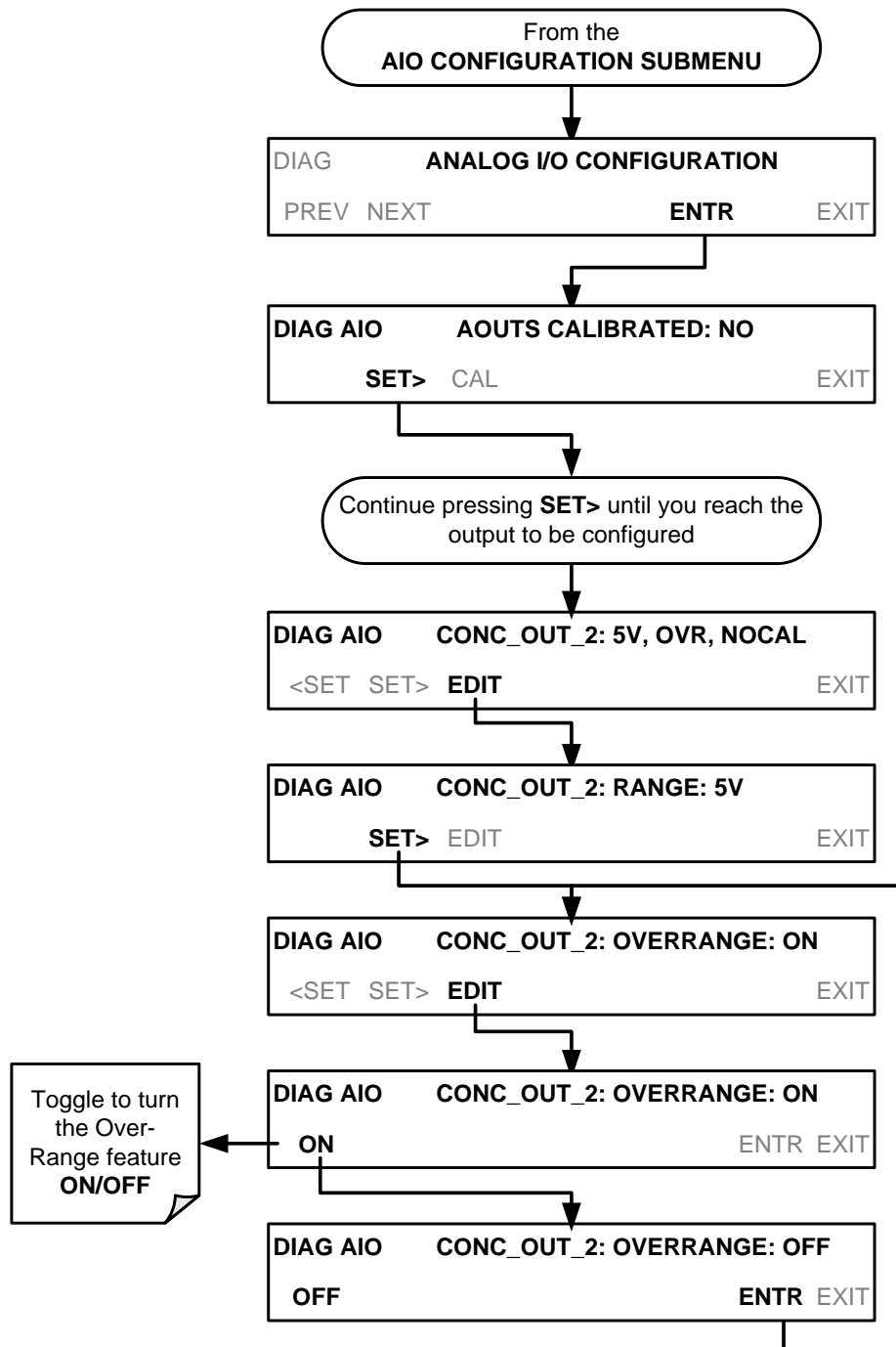

5.10.5. ADDING A RECORDER OFFSET TO AN ANALOG OUTPUT

Some analog signal recorders require that the zero signal be significantly different from the baseline of the recorder in order to record slightly negative readings from noise around the zero point. This can be achieved in the T803 by defining a zero offset, a small voltage (e.g., 10% of span).

To add a zero offset to a specific analog output channel, select the **ANALOG I/O CONFIGURATION** submenu (see Section 5.10.1) then press:

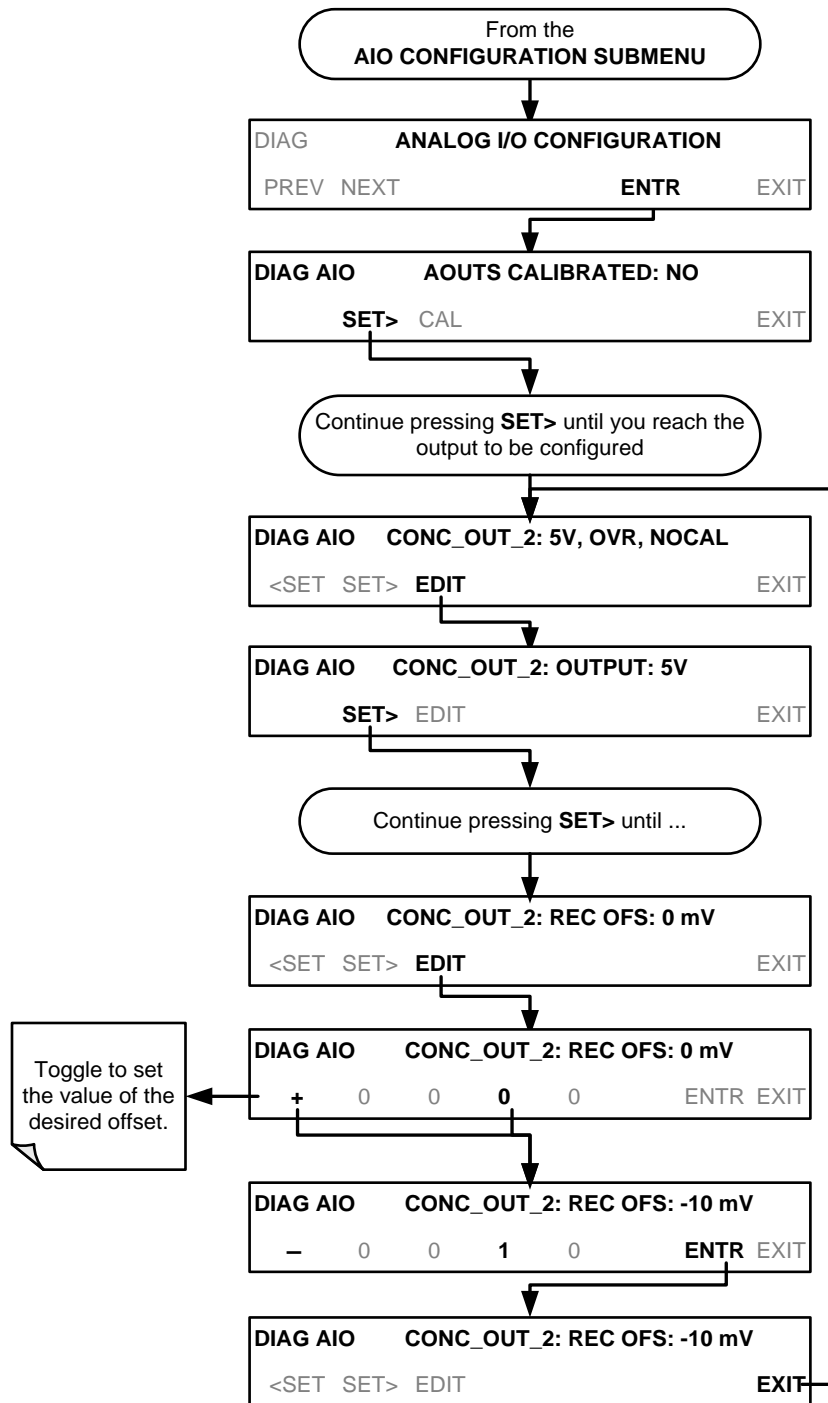

5.10.6. SELECTING A TEST CHANNEL FUNCTION FOR OUTPUT A4

The test functions available to be reported are:

Table 5-7: Test Channels Functions available on the T803's Analog Output

TEST CHANNEL	DESCRIPTION	ZERO	FULL SCALE
NONE	Test Channel is turned off		
SAMPLE PRESSURE	The absolute pressure of the Sample gas as measured by a pressure sensor located inside the sample chamber.	0 "Hg	40 "Hg
SAMPLE FLOW	Sample mass flow rate as measured by the flow rate sensor in the sample gas stream.	0 cm ³ /m	1000 cm ³ /m
CO2 CELL TEMP	The temperature of the gas inside the CO ₂ sensor sample chamber.	0°C	70°C
O2 CELL TEMP	The temperature of the gas inside the O ₂ sensor sample chamber.	0°C	70°C
CHASSIS TEMP	The temperature inside the analyzer chassis.	0°C	70°C

Once a function is selected, the instrument not only begins to output a signal on the analog output, but also adds **TEST** to the list of test functions viewable via the front panel display.

To activate the **TEST** Channel and select a function (in this example **SAMPLE PRESSURE**), press:

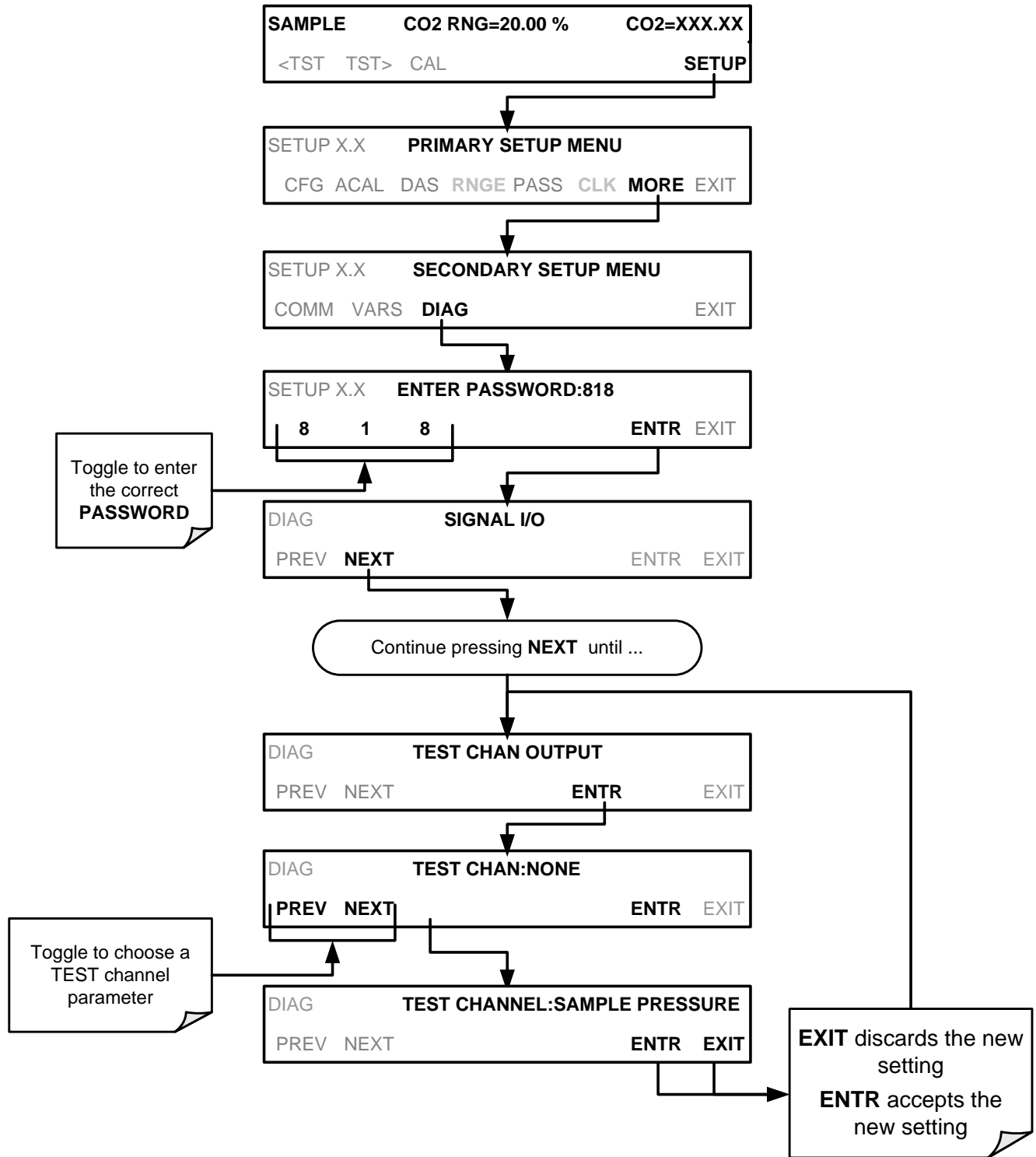

(The ACAL submenu in the Primary Setup Menu is a special configuration; consult factory).

5.10.7. AIN CALIBRATION

This is the sub-menu to conduct a calibration of the T803 analyzer's analog inputs. This calibration should only be necessary after major repair such as a replacement of CPU, motherboard or power supplies.

To perform an analog input calibration, select the **ANALOG I/O CONFIGURATION** submenu (see Section 5.10.1) then press:

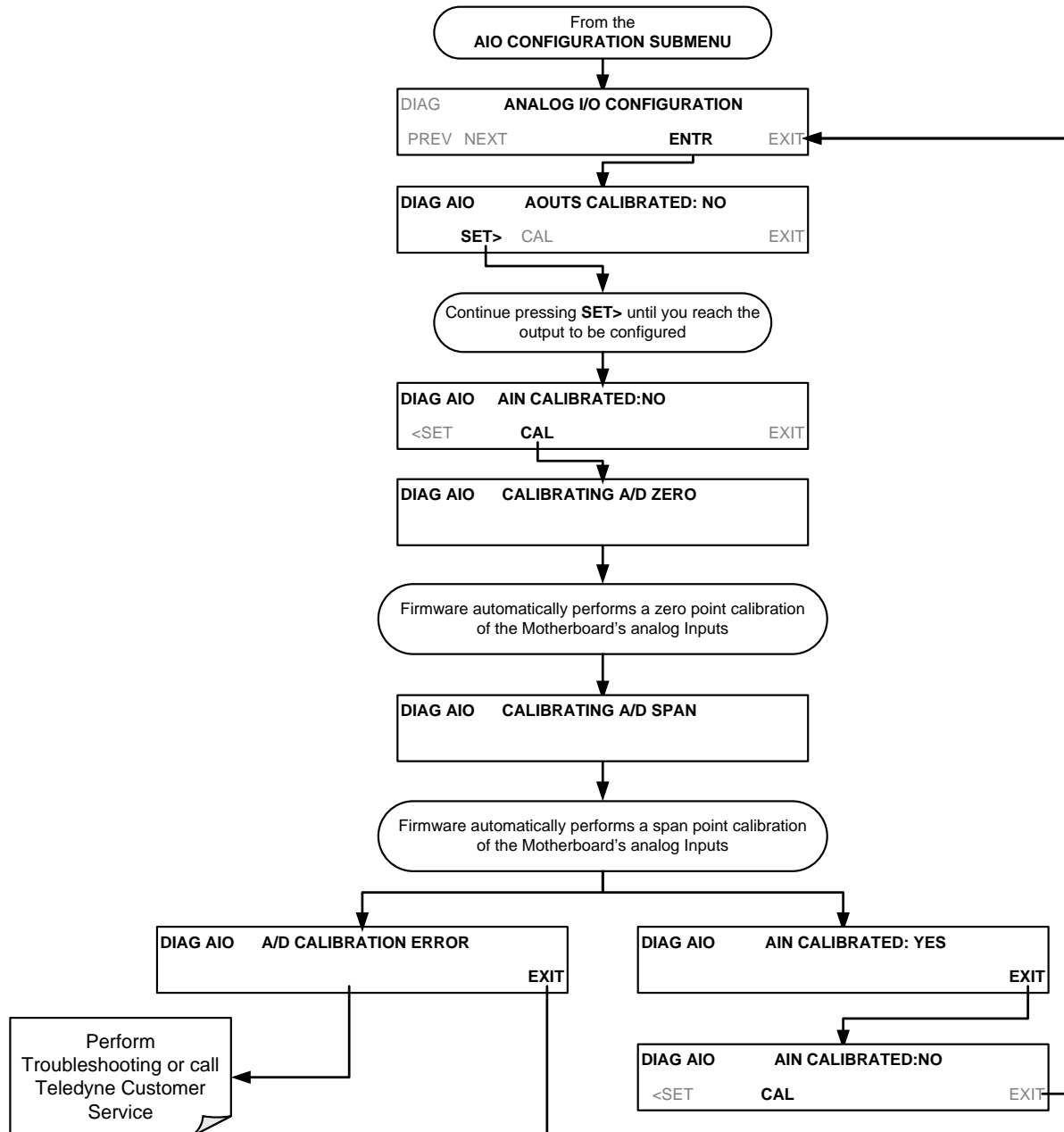

5.10.8. ANALOG INPUTS (XIN1...XIN8) OPTION CONFIGURATION

To configure the analyzer's optional analog inputs, define for each channel:

- gain (number of units represented by 1 volt)
- offset (volts)
- engineering units to be represented in volts (each press of the touchscreen button scrolls the list of alphanumeric characters from A-Z and 0-9)
- whether to display the channel in the Test functions

To adjust settings for the Analog Inputs option parameters press:

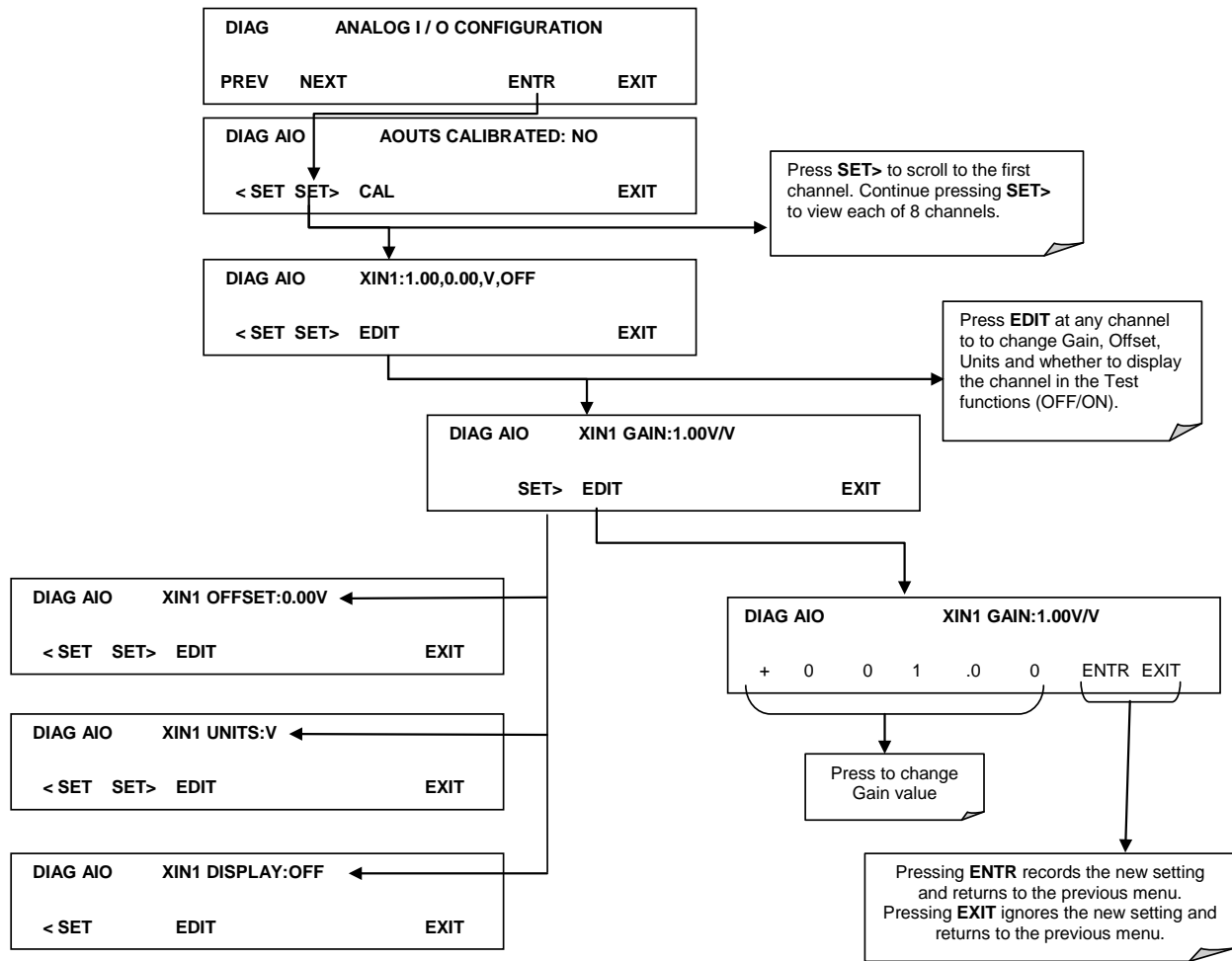

5.11. SETUP → MORE → ALRM: USING THE GAS CONCENTRATION ALARMS (OPTION 61)

The T803 includes two concentration alarms. Each alarm has a user-settable limit, and is associated with an opto-isolated TTL relay accessible via the status output connector on the instrument's back panel (See Section 3.3.1.4). If the concentration measured by the instrument rises above that limit, the alarm's status output relay is closed.

The default settings for **ALM1** and **ALM2** are:

Table 5-8: Concentration Alarm Default Settings

ALARM	STATUS	LIMIT SET POINT
O2 ALARM1	Disabled	10.00 %
O2 ALARM2	Disabled	30.0 %
CO2 ALARM1	Disabled	5.000 %
CO2 ALARM2	Disabled	10.00 %

Note

To prevent the concentration alarms from activating during span calibration operations make sure to press CAL button prior to introducing span gas into the analyzer..

5.11.1. SETTING THE T803 OPTION 61 CONCENTRATION ALARM LIMITS

To enable concentration alarms and set the Limit points, press:

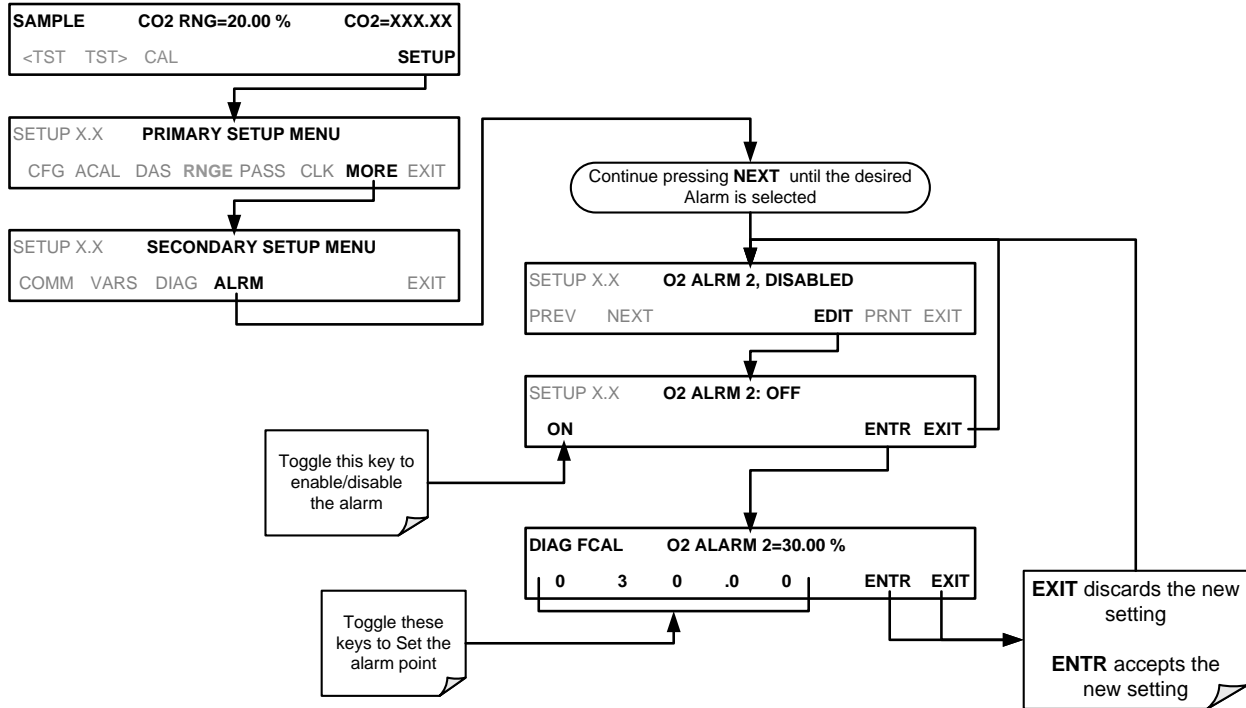

(The ACAL submenu in the Primary Setup Menu is a special configuration; consult factory).

This page intentionally left blank.

6. COMMUNICATIONS SETUP AND OPERATION

The T803 is equipped with an Ethernet port, a USB port and two serial communication (COM) ports (RS232 and COM2) located on the rear panel (see Figure 3-2). Both COM ports operate similarly and give the user the ability to communicate with, issue commands to, and receive data from the analyzer through an external computer system or terminal.

This section provides pertinent information regarding communication equipment, describes the instrument's communications modes, presents configuration instructions for the communications ports, and provides instructions for their use, including communications protocol. Data acquisition is presented in Section 7. By default, both COM ports operate on the RS-232 protocol.

6.1. DATA TERMINAL/COMMUNICATION EQUIPMENT (DTE DCE)

RS-232 was developed for allowing communications between data terminal equipment (DTE) and data communication equipment (DCE). Basic data terminals always fall into the DTE category whereas modems are always considered DCE devices.

Electronically, the difference between the DCE and DTE is the pin assignment of the Data Receive and Data Transmit functions.

- DTE devices receive data on Pin 2 and transmit data on Pin 3.
- DCE devices receive data on Pin 3 and transmit data on Pin 2.

A switch located below the serial ports on the rear panel allows the user to switch between DTE (for use with data terminals) or DCE (for use with modems). Since computers can be either DTE or DCE, check your computer to determine which mode to use.

6.2. COMMUNICATION MODES, BAUD RATE AND PORT TESTING

Use the **SETUP>MORE>COMM** menu to configure COM1 (labeled **RS232** on instrument rear panel) and/or COM2 (labeled **COM2** on instrument rear panel) for communication modes, baud rate and/or port testing for correct connection. If using a USB option communication connection, setup requires downloading the USB driver and configuring per Section 6.4.

6.2.1. COM PORT COMMUNICATION MODES

Each of the analyzer's serial ports can be configured to operate in a number of different modes, listed in Table 6-1. As modes are selected, the analyzer sums the mode ID numbers and displays this combined number on the front panel display. For example, if quiet mode (01), computer mode (02) and Multi-Drop-Enabled mode (32) are selected, the analyzer would display a combined **MODE ID** of **35**.

Table 6-1: COM Port Communication Modes

MODE ¹	ID	DESCRIPTION
QUIET	1	Quiet mode suppresses any feedback from the analyzer (such as warning messages) to the remote device and is typically used when the port is communicating with a computer program where such intermittent messages might cause communication problems. Such feedback is still available but a command must be issued to receive them.
COMPUTER	2	Computer mode inhibits echoing of typed characters and is used when the port is communicating with a computer operated control program.
HESSEN PROTOCOL	16	The Hessen communications protocol is used in some European countries. TELEDYNE API PN 02252 contains more information on this protocol.
E, 8, 1	8192	When turned on this mode switches the COM port settings from <ul style="list-style-type: none"> • NO PARITY; 8 data bits; 1 stop bit to EVEN PARITY; 8 data bits; 1 stop bit.
E, 7, 1	2048	When turned on this mode switches the COM port settings from <ul style="list-style-type: none"> • NO PARITY; 8 DATA BITS; 1 stop bit to EVEN PARITY; 7 DATA BITS; 1 stop bit.
RS-485	1024	Configures the COM2 Port for RS-485 communication. RS-485 mode has precedence over multidrop mode if both are enabled.
SECURITY	4	When enabled, the serial port requires a password before it will respond (see Section 8.2.1.6). The only command that is active is the help screen (? CR).
MULTIDROP PROTOCOL	32	Multidrop protocol allows a multi-instrument configuration on a single communications channel. Multidrop requires the use of instrument IDs.
ENABLE MODEM	64	Enables to send a modem initialization string at power-up. Asserts certain lines in the RS-232 port to enable the modem to communicate.
ERROR CHECKING ²	128	Fixes certain types of parity errors at certain Hessen protocol installations.
XON/XOFF HANDSHAKE ²	256	Disables XON/XOFF data flow control also known as software handshaking.
HARDWARE HANDSHAKE	8	Enables CTS/RTS style hardwired transmission handshaking. This style of data transmission handshaking is commonly used with modems or terminal emulation protocols as well as by Teledyne Instrument's APICOM software.
HARDWARE FIFO	512	Disables the HARDWARE FIFO (First In – First Out), When FIFO is enabled it improves data transfer rate for that COM port.
COMMAND PROMPT	4096	Enables a command prompt when in terminal mode.

¹ Modes are listed in the order in which they appear in the **SETUP → MORE → COM → COM[1 OR 2] → MODE** menu

² The default setting for this feature is **ON**. Do not disable unless instructed to by Teledyne API Technical Support personnel.

Note

Communication Modes for each COM port must be configured independently.

Press the following buttons to select communication modes for one of the COM Ports, such as the following example where **RS-485** mode is enabled:

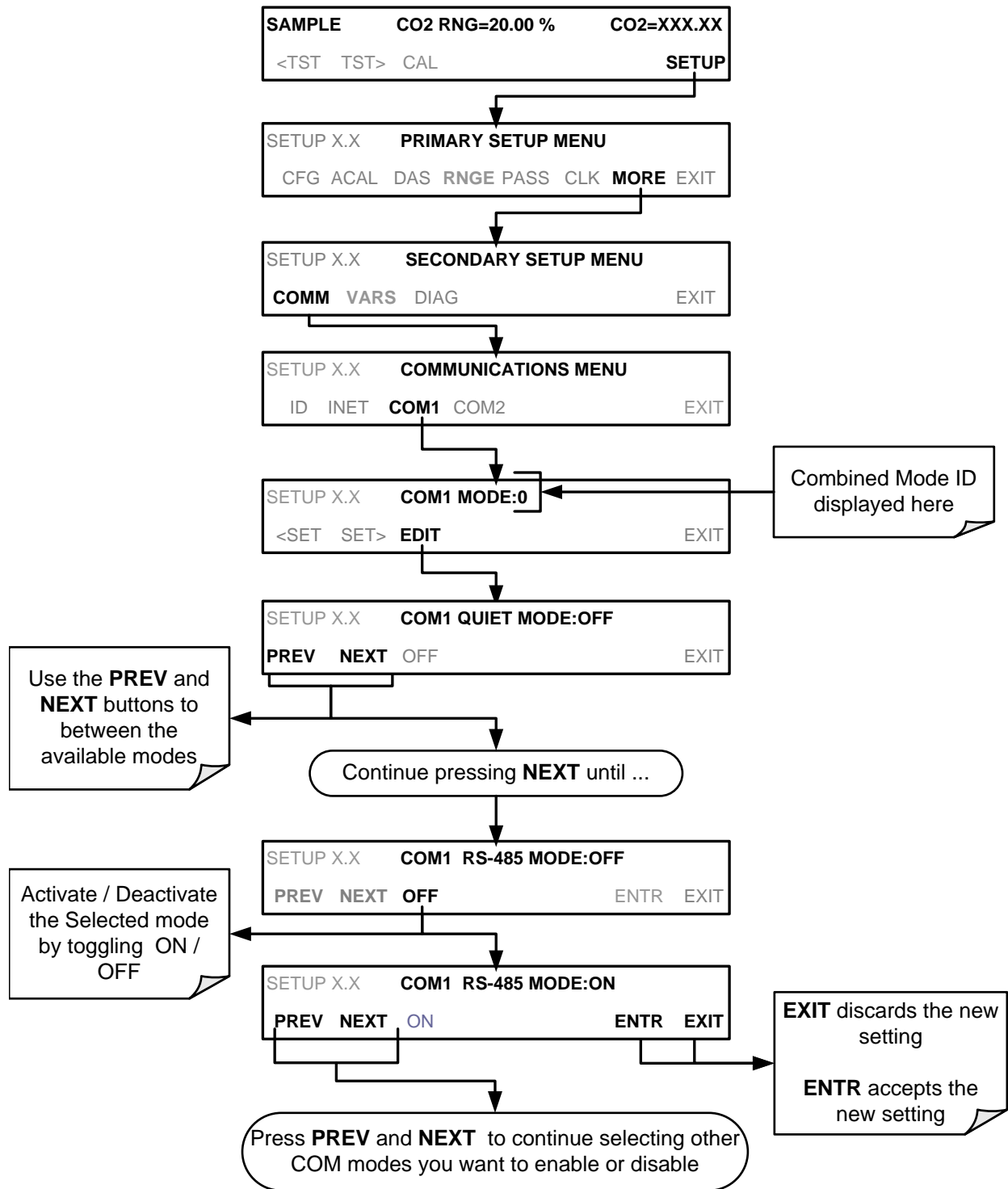

(The ACAL submenu in the Primary Setup Menu is a special configuration; consult factory).

6.2.2. COM PORT BAUD RATE

To select the baud rate of either one of the COM Ports, press:

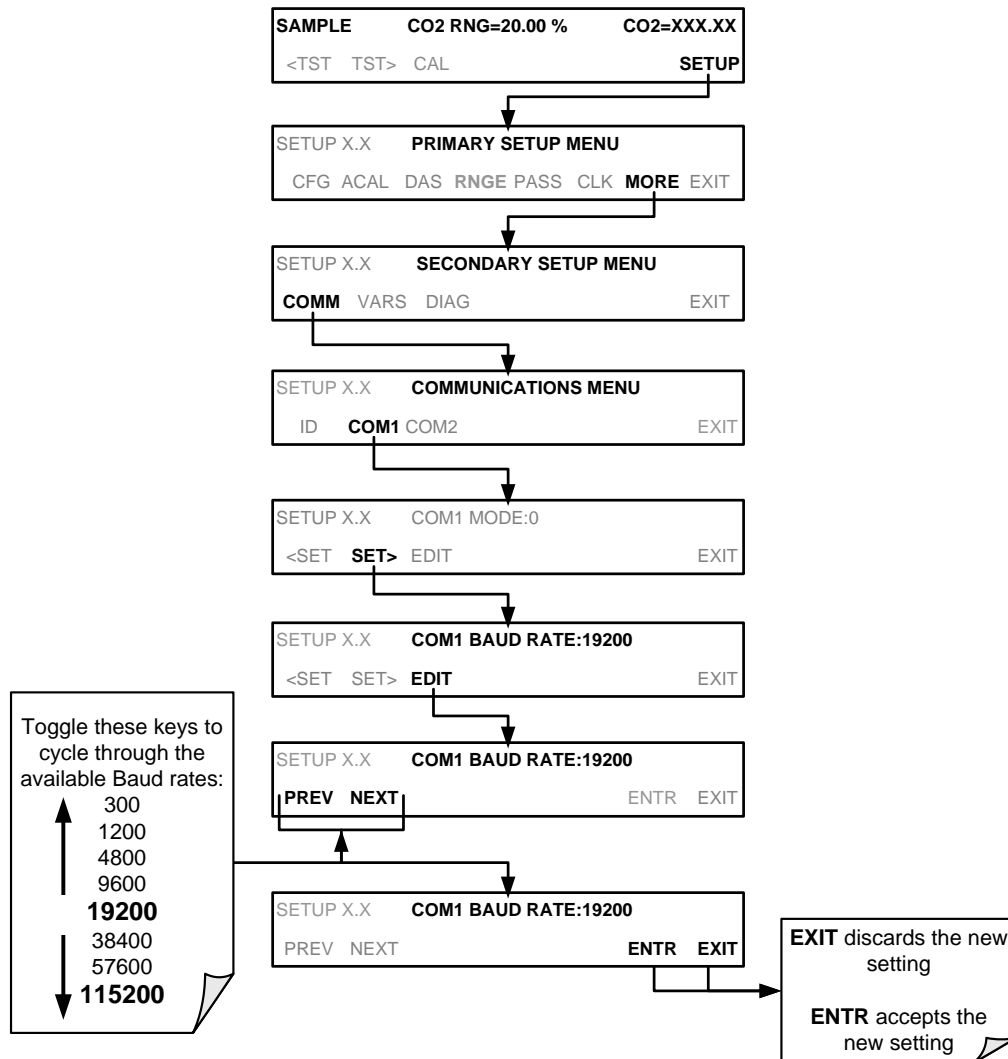

6.2.3. COM PORT TESTING

The serial ports can be tested for correct connection and output in the **COM** menu. This test sends a string of 256 'w' characters to the selected COM port. While the test is running, the red LED on the rear panel of the analyzer should flicker.

To initiate the test press the following button sequence.

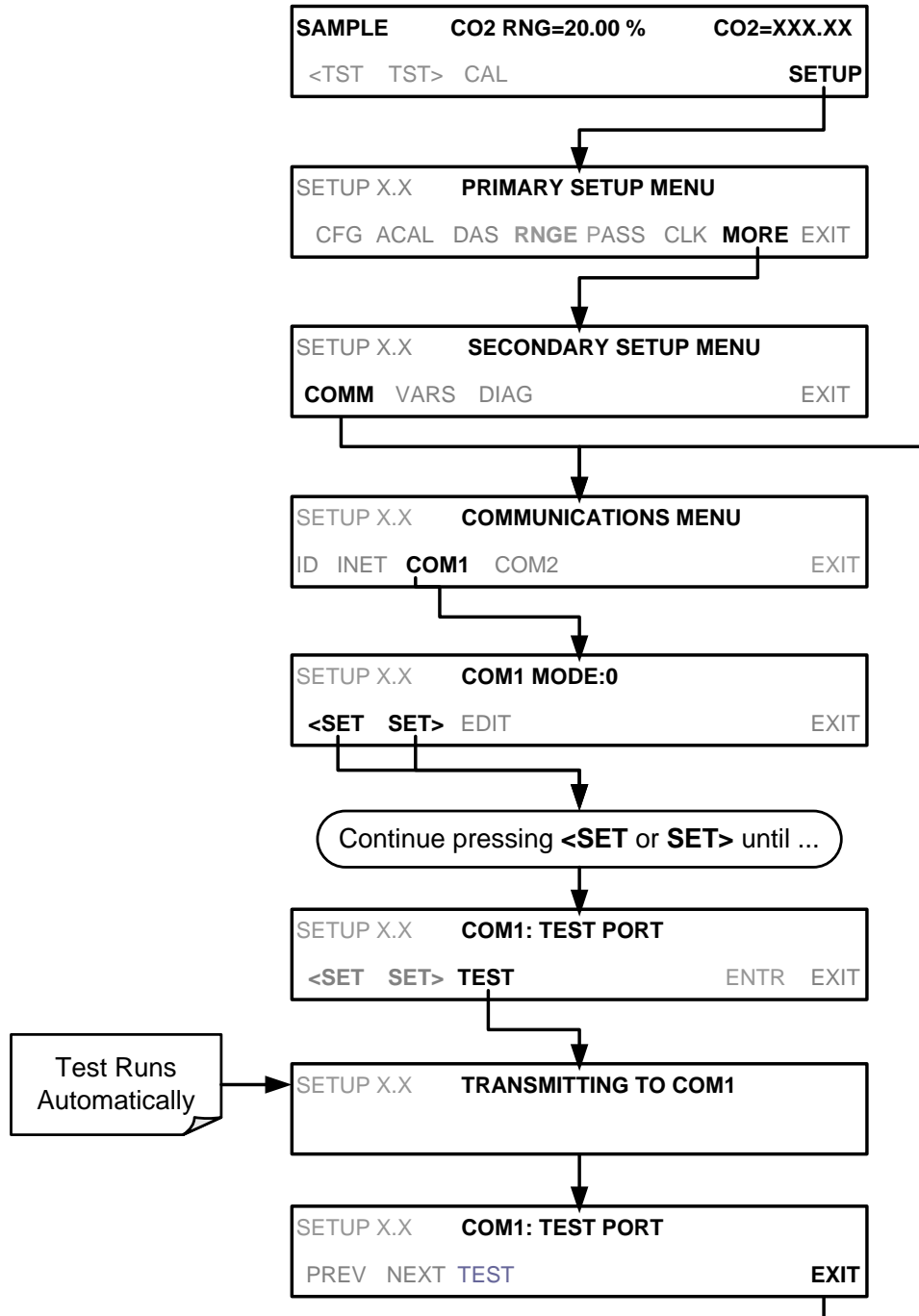

6.2.4. MACHINE ID

Each type of Teledyne API's analyzer is configured with a default **ID** code. The default **ID** code for the T803 analyzers is **803**.

The **ID** number is only important if more than one analyzer is connected to the same communications channel such as when several analyzers are:

- on the same Ethernet LAN (see Section 6.3);
- in a RS-232 multidrop chain (see Section 3.3.1.8) or;
- operating over a RS-485 network (see Section 3.3.1.8).

If two analyzers of the same model type are used on one channel, the **ID** codes of one or both of the instruments needs to be changed.

To edit the instrument's ID code, press:

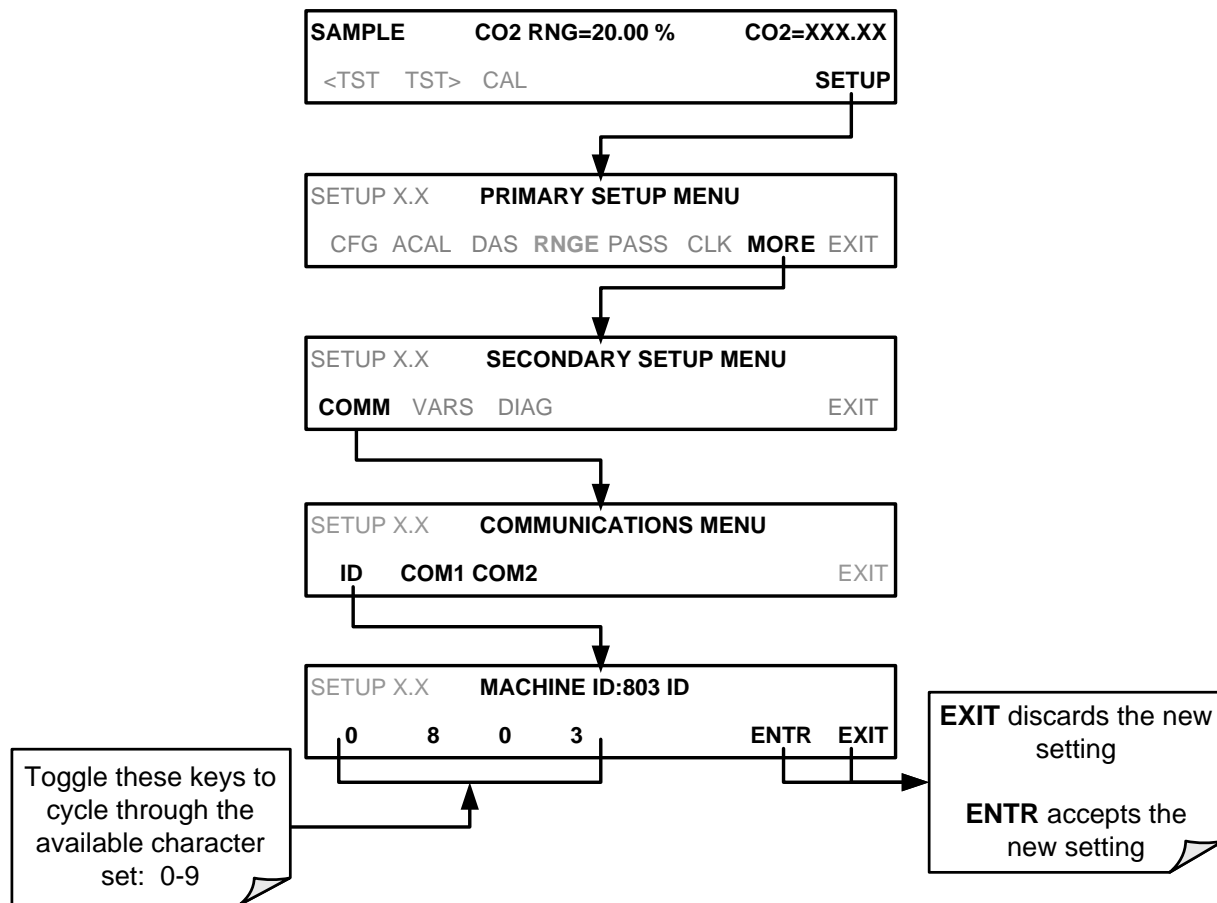

The ID can also be used for to identify any one of several analyzers attached to the same network but situated in different physical locations.

6.3. REMOTE ACCESS VIA THE ETHERNET

For network or Internet communication, the analyzer can be connected to any standard 10BaseT or 100BaseT Ethernet network via low-cost network hubs, switches or routers. The interface operates as a standard TCP/IP device on port 3000. This allows a remote computer to connect through the Internet to the analyzer using APICOM, terminal emulators or other programs.

The Ethernet cable connector on the rear panel has two LEDs indicating the Ethernet's current operating status.

Table 6-2: Ethernet Status Indicators

LED	FUNCTION
amber (link)	On when connection to the LAN is valid.
green (activity)	Flickers during any activity on the LAN.

The analyzer is shipped with DHCP enabled by default. This allows the instrument to be connected to a network or router with a DHCP server. The instrument will automatically be assigned an IP address by the DHCP server. This configuration is useful for quickly getting an instrument up and running on a network. However, for permanent Ethernet connections, a static IP address should be used. Section 6.3.2 details how to configure the instrument with a static IP address.

6.3.1. CONFIGURING THE ETHERNET USING DHCP

The Ethernet for your T803 uses Dynamic Host Configuration Protocol (DHCP) to configure its interface with your LAN automatically. This requires that your network servers also be running DHCP. The analyzer will do this the first time you turn the instrument on after it has been physically connected to your network.

Note

Check the INET settings the first time you power up your analyzer after it has been physically connected to the LAN/Internet to make sure that the DHCP has successfully downloaded the appropriate information from you network server(s). The Ethernet configuration properties (Table 6-3) are viewable via the analyzer's front panel display.

Table 6-3: LAN/Internet Configuration Properties

PROPERTY	DEFAULT STATE	DESCRIPTION
DHCP	ON	This displays whether the DHCP is turned ON or OFF. Press EDIT and toggle ON for automatic configuration after first consulting network administrator.
INSTRUMENT IP ADDRESS		This string of four packets of 1 to 3 numbers each (e.g. 192.168.76.55.) is the address of the analyzer itself.
GATEWAY IP ADDRESS	0.0.0.0	Can only be edited when DHCP is set to OFF. A string of numbers very similar to the Instrument IP address (e.g. 192.168.76.1.) that is the address of the computer used by your LAN to access the Internet.
SUBNET MASK	0.0.0.0	Can only be edited when DHCP is set to OFF. Also a string of four packets of 1 to 3 numbers each (e.g. 255.255.252.0) that identifies the LAN to which the device is connected. All addressable devices and computers on a LAN must have the same subnet mask. Any transmissions sent to devices with different subnets are assumed to be outside of the LAN and are routed through the gateway computer onto the Internet.
TCP PORT¹	3000	This number defines the terminal control port by which the instrument is addressed by terminal emulation software, such as Internet or Teledyne API's APICOM.
HOST NAME	T803	The name by which your analyzer will appear when addressed from other computers on the LAN or via the Internet. To change, see Section 6.3.3.
¹ Do not change the setting for this property unless instructed to by Teledyne API's Technical Support personnel.		

Note If the gateway IP, instrument IP and the subnet mask are all zeroes (e.g. "0.0.0.0"), the DHCP was not successful in which case you may have to configure the analyzer's Ethernet properties manually. See your network administrator.

Note Check the INET settings the first time you power up your analyzer after it has been physically connected to the LAN/Internet, to make sure that the DHCP has successfully downloaded the appropriate information from your network server(s). The Ethernet configuration properties (Table 6-3) are viewable via the analyzer's front panel display.

To view the above properties list in Table 6-3 press:

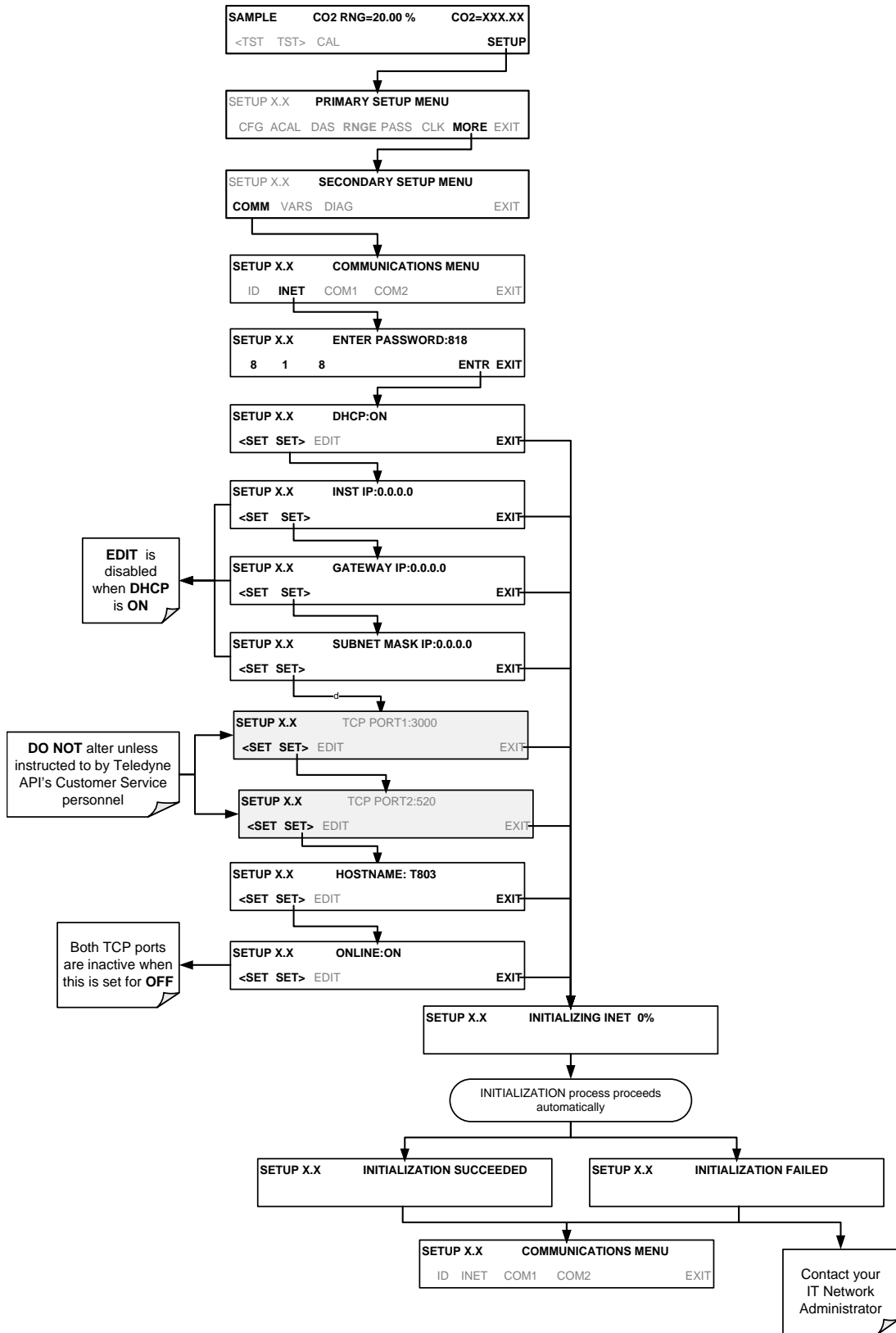

(The ACAL submenu in the Primary Setup Menu is a special configuration; consult factory).

6.3.2. MANUALLY CONFIGURING THE NETWORK IP ADDRESSES

There are several circumstances when you may need to configure the interface settings of the analyzer's Ethernet card manually:

- your LAN is not running a DHCP software package
- the DHCP software is unable to initialize the analyzer's interface
- you wish to create a static IP (recommended)

1. Connect a cable from the analyzer's Ethernet port to a Local Area Network (LAN) or Internet port.
2. Access Ethernet configuration through: SETUP>MORE>COMM>INET.
3. Follow the setup sequence as shown in the illustrations that follow, and edit the Instrument and Gateway IP addresses and Subnet Mask to the desired settings. (From the computer, enter the same information through an application such as HyperTerminal).

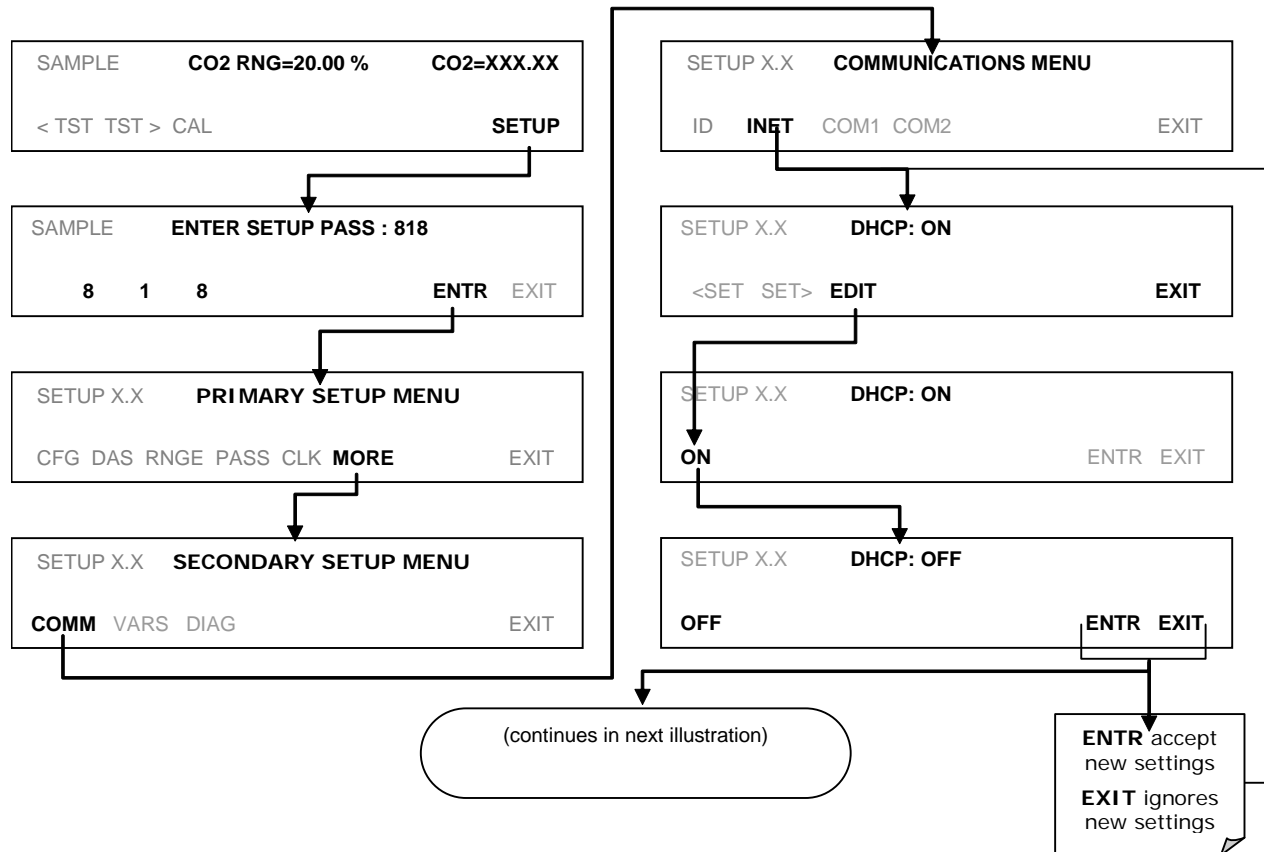

Internet Configuration Touchscreen Functions

BUTTON	FUNCTION
[0]	Press this key to cycle through the range of numerals and available characters ("0 - 9" & ". ")
<CH CH>	Moves the cursor one character left or right.
DEL	Deletes a character at the cursor location.
ENTR	Accepts the new setting and returns to the previous menu.
EXIT	Ignores the new setting and returns to the previous menu.

Buttons appear only as applicable.

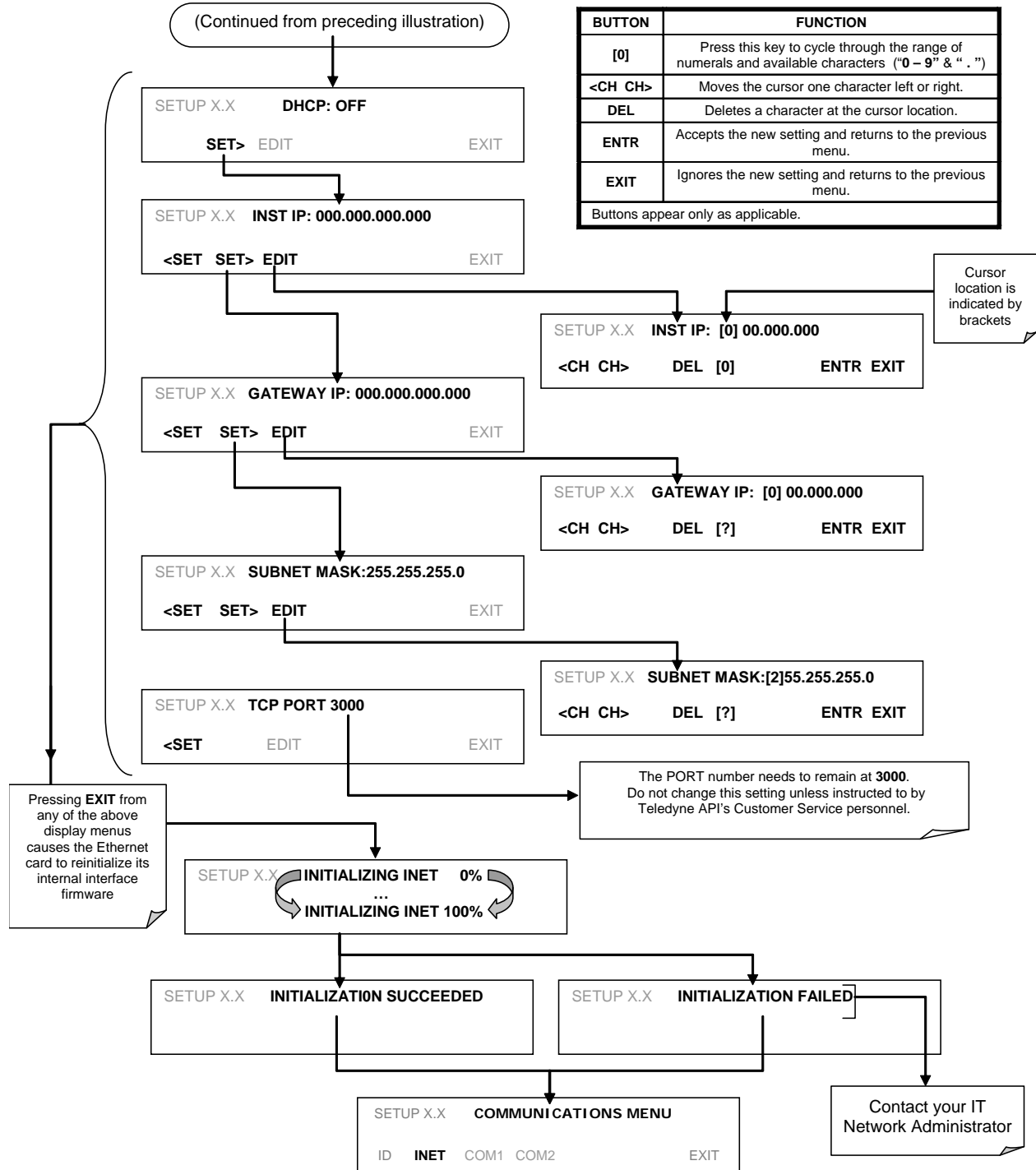

6.3.3. CHANGING THE ANALYZER'S HOSTNAME

The **HOSTNAME** is the name by which the analyzer appears on your network.

- The default name for all Teledyne API T803 analyzers is **T803**.

To change this name (particularly if you have more than one T803 analyzer on your network), press:

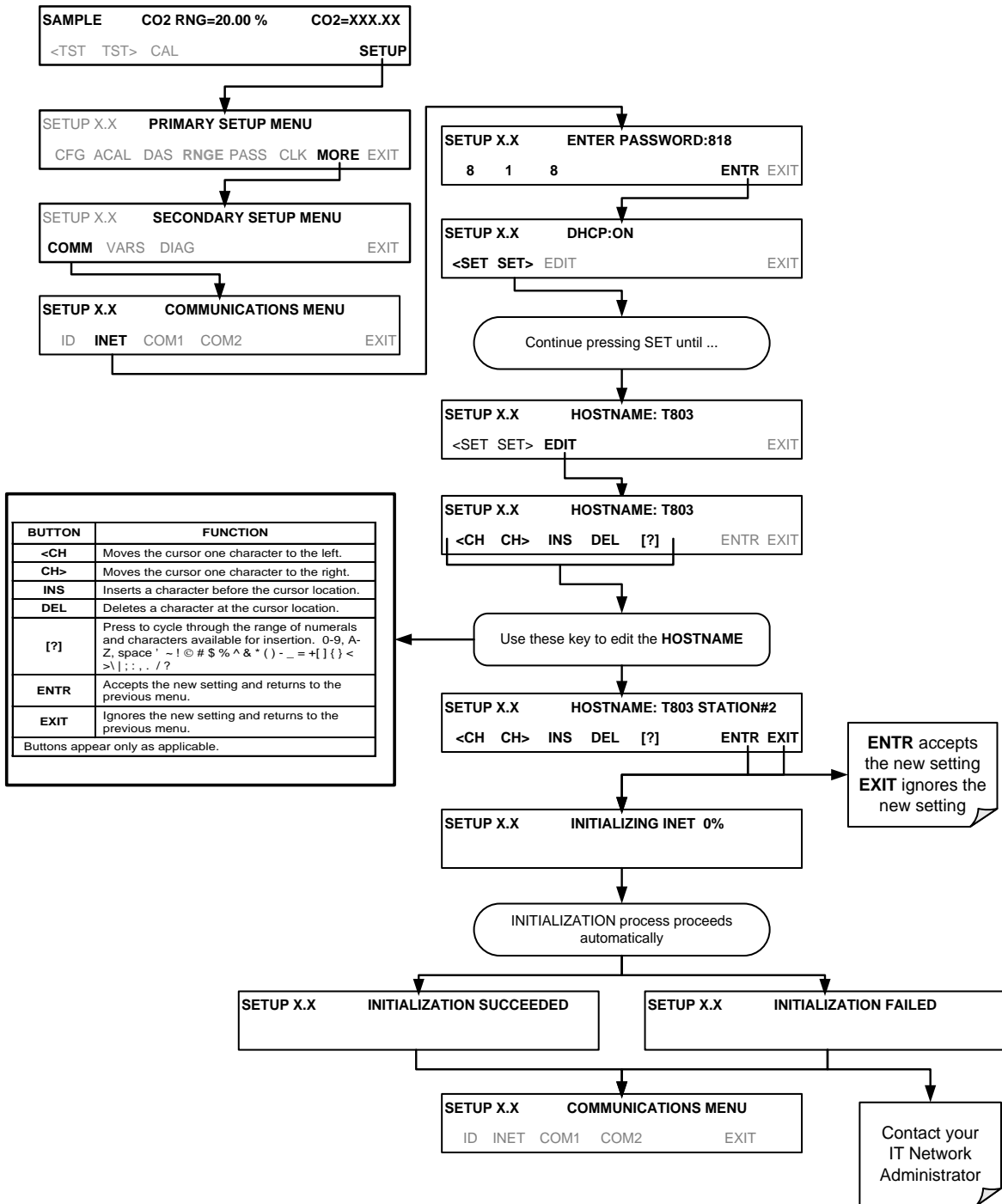

(The ACAL submenu in the Primary Setup Menu is a special configuration; consult factory).

6.4. USB PORT FOR REMOTE ACCESS

The analyzer can be operated through a personal computer by downloading the TAPI USB driver and directly connecting their respective USB ports.

1. Install the Teledyne T-Series USB driver on your computer, downloadable from the Teledyne API website under Help Center>Software Downloads (www.teledyne-api.com/software).
2. Run the installer file: "TAPIVCPInstaller.exe"

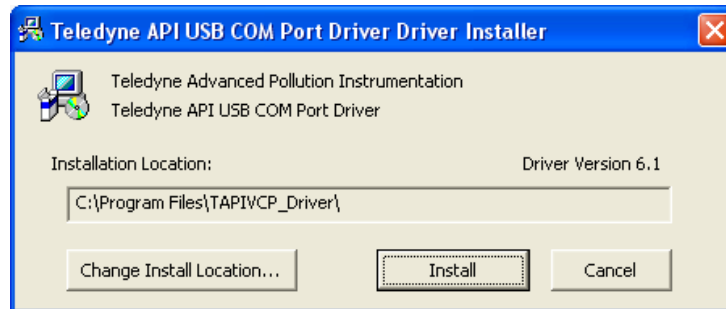

3. Connect the USB cable between the USB ports on your personal computer and your analyzer. The USB cable should be a Type A – Type B cable, commonly used as a USB printer cable.
4. Determine the Windows XP Com Port number that was automatically assigned to the USB connection. (Start → Control Panel → System → Hardware → Device Manager). This is the com port that should be set in the communications software, such as APIcom or Hyperterminal.

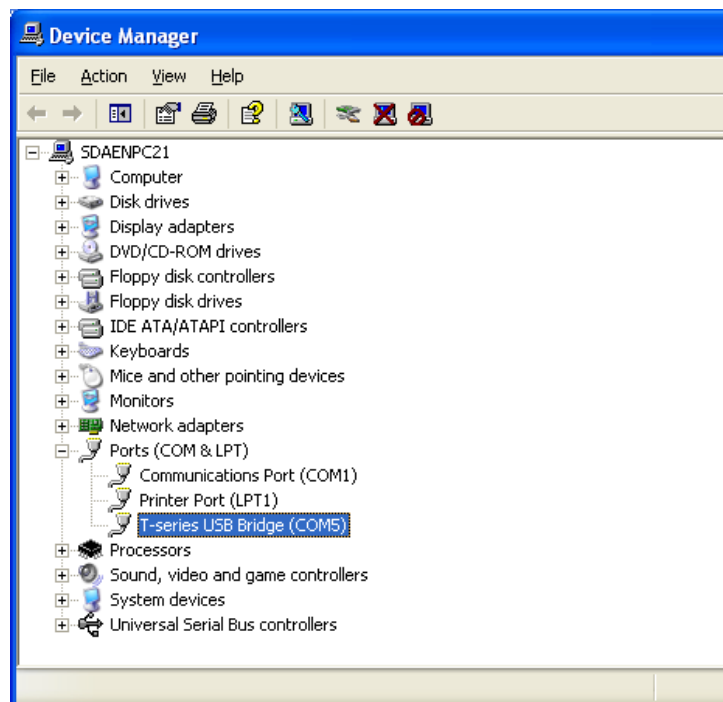

Refer to the Quick Start (*Direct Cable Connection*) section of the Teledyne APIcom Manual, PN 07463.

- In the instrument's SETUP>MORE>COMM>COM2 menu, make the following settings:

Baud Rate: 115200			
COM2 Mode Settings:			
Quiet Mode	ON	SECURITY MODE	OFF
Computer Mode	ON	MULTIDROP MODE	OFF
MODBUS RTU	OFF	ENABLE MODEM	OFF
MODBUS ASCII	OFF	ERROR CHECKING	ON
E,8,1 MODE	OFF	XON/XOFF HANDSHAKE	OFF
E,7,1 MODE	OFF	HARDWARE HANDSHAKE	OFF
RS-485 MODE	OFF	HARDWARE FIFO	ON
		COMMAND PROMPT	OFF

- Next, configure your communications software, such as APIcom. Use the COM port determined in Step 4 and the baud rate set in Step 5. The figures below show how these parameters would be configured in the Instrument Properties window in APIcom when configuring a new instrument. See the APIcom manual (PN 07463) for more details.

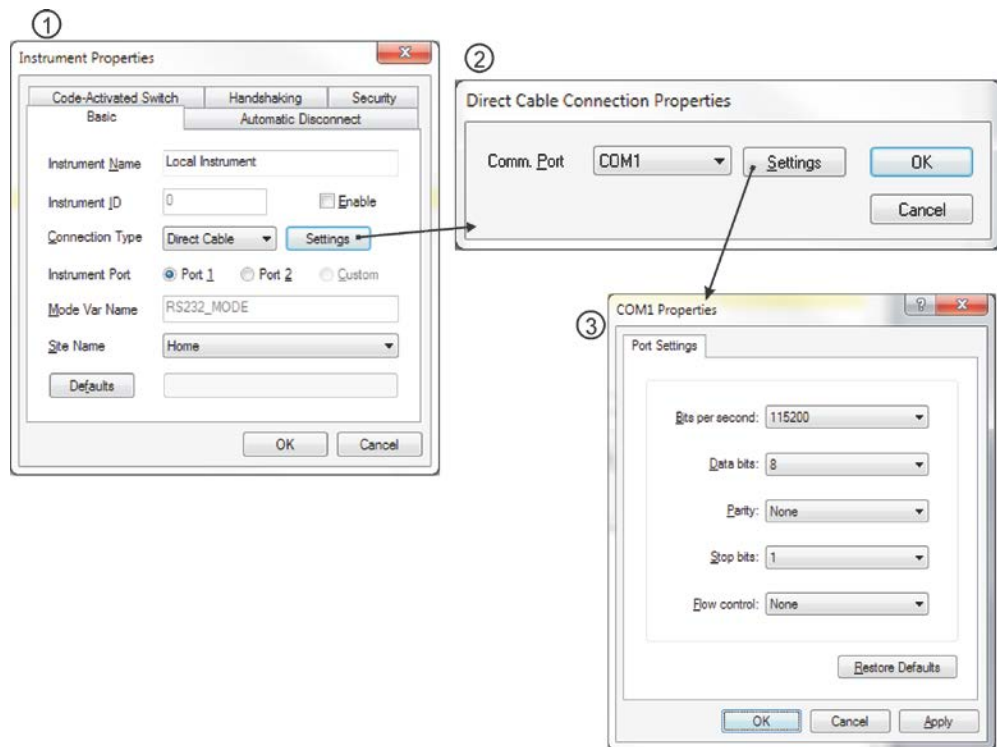

Note

- **USB configuration requires that the baud rates of the instrument and the PC match; check the PC baud rate and change if needed.**
- **Using the USB port disallows use of the rear panel COM2 port except for multidrop communication.**

6.5. COMMUNICATIONS PROTOCOLS

This section presents MODBUS and HESSEN information.

6.5.1. MODBUS SETUP

The following set of instructions assumes that the user is familiar with MODBUS communications, and provides minimal information to get started. For additional instruction, please refer to the Teledyne API MODBUS manual, PN 06276. Also refer to www.modbus.org for MODBUS communication protocols.

Minimum Requirements

- Instrument firmware with MODBUS capabilities installed.
- MODBUS-compatible software (TAPI uses MODBUS Poll for testing; see www.modbustools.com)
- Personal computer
- Communications cable (Ethernet or USB or RS232)
- Possibly a null modem adapter or cable

Actions

Set Com Mode parameters	<p>Comm</p> <p>Ethernet: Using the front panel menu, go to SETUP – MORE – COMM – INET; scroll through the INET submenu until you reach TCP PORT 2 (the standard setting is 502), then continue to TCP PORT 2 MODBUS TCP/IP; press EDIT and toggle the menu button to change the setting to ON, then press ENTR. (Change Machine ID if needed: see “Slave ID”).</p> <p>USB/RS232: Using the front panel menu, go to SETUP – MORE – COMM – COM2 – EDIT; scroll through the COM2 EDIT submenu until the display shows COM2 MODBUS RTU: OFF (press OFF to change the setting to ON. Scroll NEXT to COM2 MODBUS ASCII and ensure it is set to OFF. Press ENTR to keep the new settings. (If RTU is not available with your communications equipment, set the COM2 MODBUS ASCII setting to ON and ensure that COM2 MODBUS RTU is set to OFF. Press ENTR to keep the new settings).</p> <p>Slave ID</p> <p>If your analyzer is connected to a network with at least one other analyzer of the same model, a unique Slave ID must be assigned to each. Using the front panel menu, go to SETUP – MORE – COMM – ID. The MACHINE ID default is the same as the model number. Toggle the menu buttons to change the ID.</p>
Reboot analyzer	For the settings to take effect, power down the analyzer, wait 5 seconds, and power up the analyzer.
Make appropriate cable connections	Connect your analyzer either: <ul style="list-style-type: none"> • via its Ethernet or USB port to a PC (this may require a USB-to-RS232 adapter for your PC; if so, also install the software driver from the CD supplied with the adapter, and reboot the computer if required), or • via its COM2 port to a null modem (this may require a null modem adapter or cable).
Specify MODBUS software settings (examples used here are for MODBUS Poll software)	<ol style="list-style-type: none"> 1. Click Setup / [Read / Write Definition] /. <ol style="list-style-type: none"> a. In the Read/Write Definition window (see example that follows) select a Function (what you wish to read from the analyzer). b. Input Quantity (based on your firmware’s register map). c. In the View section of the Read/Write Definition window select a Display (typically Float Inverse). d. Click OK. 2. Next, click Connection/Connect. <ol style="list-style-type: none"> a. In the Connection Setup window (see example that follows), select the options based on your computer. b. Press OK.
Read the Modbus Poll Register	Use the Register Map to find the test parameter names for the values displayed (see example that follows) If desired, assign an alias for each.

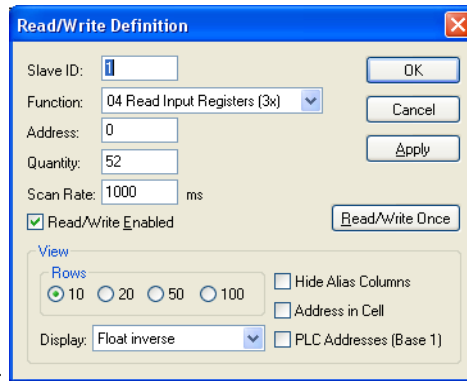

Example Read/Write Definition window:

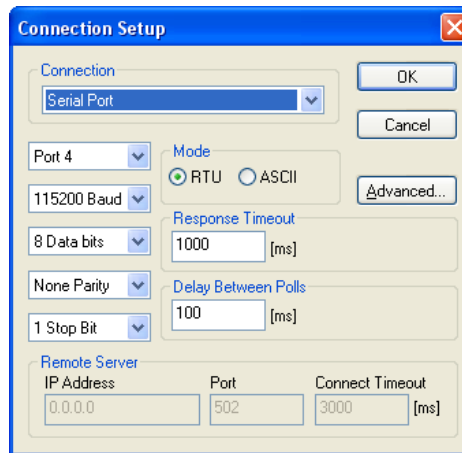

Example Connection Setup window:

Example MODBUS Poll window:

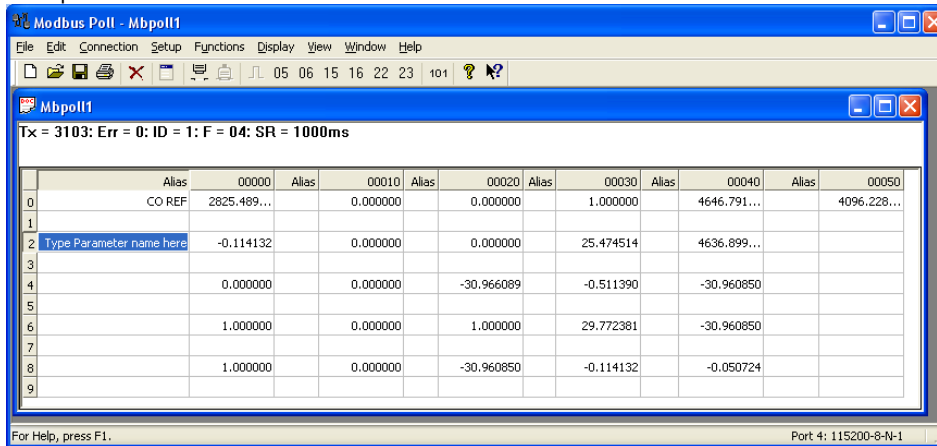

6.5.2. HESSEN

The Hessen protocol is a multidrop protocol, in which several remote instruments are connected via a common communications channel to a host computer. The remote instruments are regarded as slaves of the host computer. The remote instruments are unaware that they are connected to a multidrop bus and never

initiate Hessen protocol messages. They only respond to commands from the host computer and only when they receive a command containing their own unique ID number.

The Hessen protocol is designed to accomplish two things: to obtain the status of remote instruments, including the concentrations of all the gases measured; and to place remote instruments into zero or span calibration or measure mode. API's implementation supports both of these principal features.

The Hessen protocol is not well defined, therefore while API's application is completely compatible with the protocol itself, it may be different from implementations by other companies.

Note

The following sections describe the basics for setting up your instrument to operate over a Hessen Protocol network. For more detailed information as well as a list of host computer commands and examples of command and response message syntax, download the *Manual Addendum for Hessen Protocol* from the Teledyne API web site: <http://www.teledyne-api.com/manuals/>.

6.5.2.1. HESSEN COM PORT CONFIGURATION

Hessen protocol requires the communication parameters of the T803's COM ports to be set differently than the standard configuration as shown in the table below.

Table 6-4: RS-232 Communication Parameters for Hessen Protocol

PARAMETER	STANDARD	HESSEN
Baud Rate	300 – 115200	1200
Data Bits	8	7
Stop Bits	1	2
Parity	None	Even
Duplex	Full	Half

To change the baud rate of the T803's COM ports, See Section 6.2.2.

To change the rest of the COM port parameters listed in the table above, see Section 6.2 and Table 6-1.

Note

Make sure that the communication parameters of the host computer are also properly set.

In addition, rather than issuing commands to the instrument in rapid succession, bear in mind that the instrument software has a 200 ms latency period before it responds to commands issued by the host computer.

6.5.2.2. ACTIVATING HESSEN PROTOCOL

Once the COM port has been properly configured, the next step in configuring the T803 to operate over a Hessen protocol network is to activate the Hessen mode for COM ports and configure the communication parameters for the port(s) appropriately.

Press:

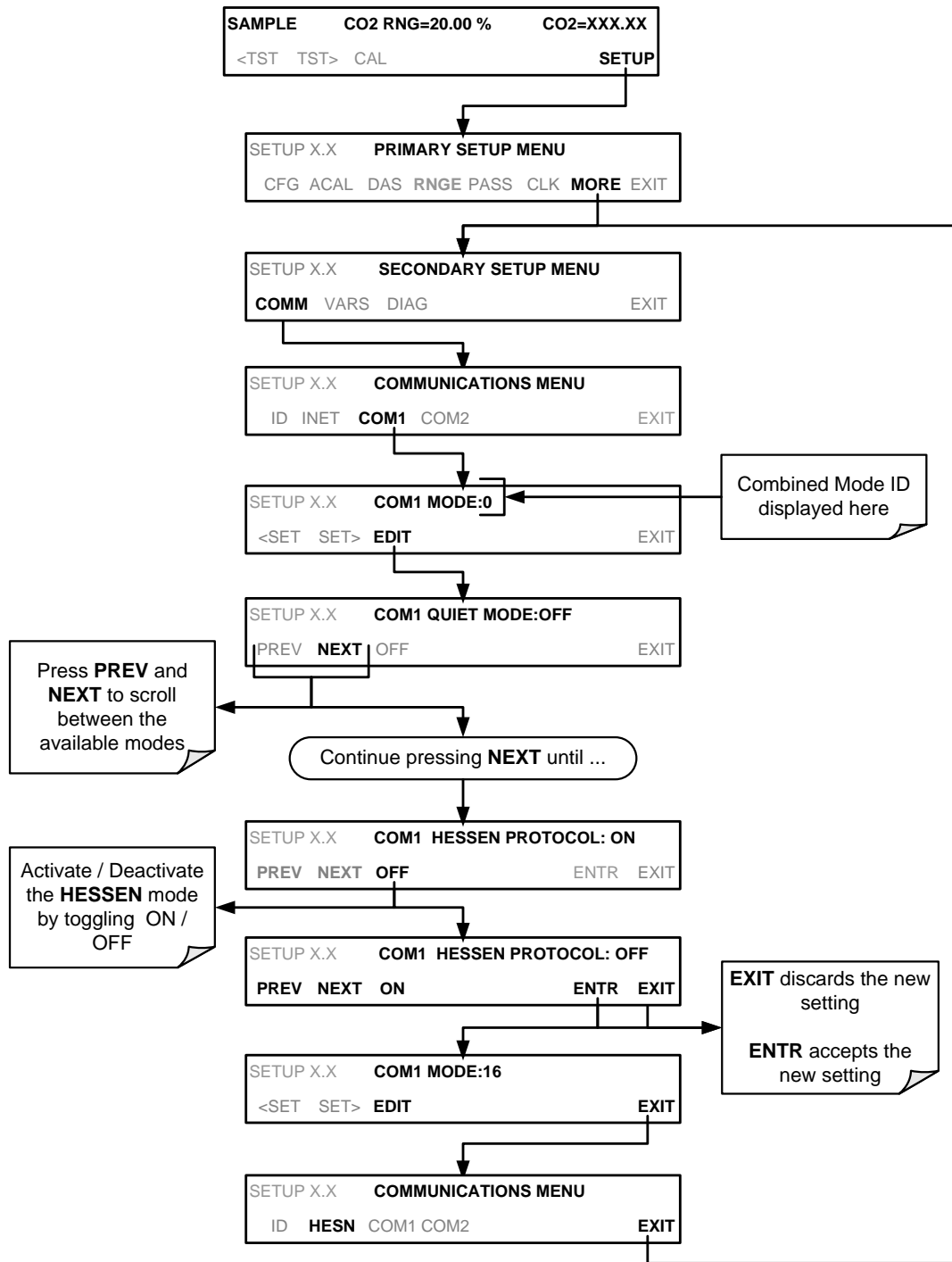

(The ACAL submenu in the Primary Setup Menu is a special configuration; consult factory).

6.5.2.3. SELECTING A HESSEN PROTOCOL TYPE

Currently there are two versions of Hessen Protocol in use. The original implementation, referred to as **TYPE 1**, and a more recently released version,

TYPE 2 that has more flexibility when operating with instruments that can measure more than one type of gas.

For more specific information about the difference between **TYPE 1** and **TYPE 2** download the *Manual Addendum for Hessen Protocol* from the Teledyne API web site: <http://www.teledyne-api.com/manuals/>.

To select a Hessen Protocol Type press:

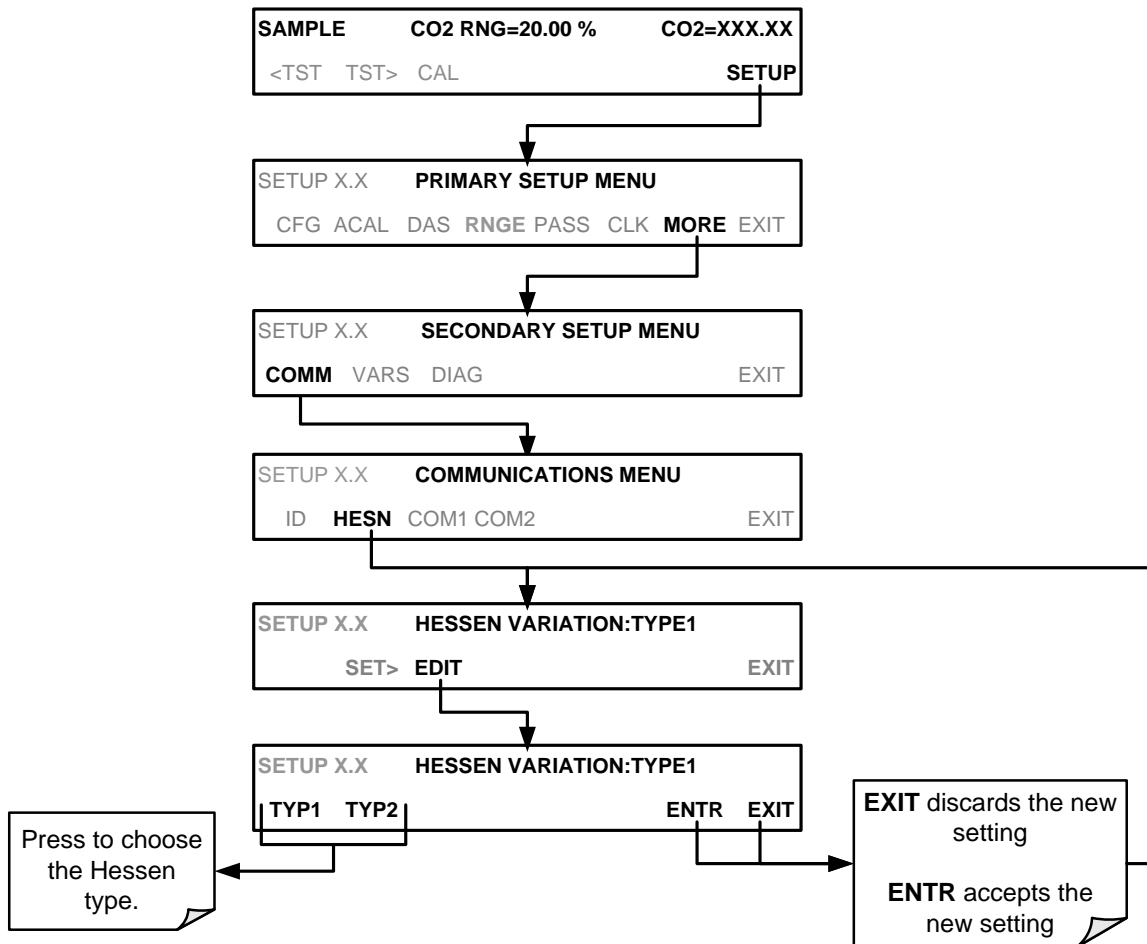

(The ACAL submenu in the Primary Setup Menu is a special configuration; consult factory).

Note

While Hessen Protocol Mode can be activated independently for COM1 and COM2, The TYPE selection affects both ports.

6.5.2.4. SETTING THE HESSEN PROTOCOL RESPONSE MODE

The Teledyne API implementation of Hessen Protocol allows the user to choose one of several different modes of response for the analyzer.

Table 6-5: Teledyne API Hessen Protocol Response Modes

MODE ID	MODE DESCRIPTION
CMD	This is the Default Setting. Responses from the instrument are encoded as the traditional command format. Style and format of responses depend on exact coding of the initiating command.
BCC	Responses from the instrument are always delimited with <STX> (at the beginning of the response, <ETX> (at the end of the response followed by a 2 digit Block Check Code (checksum), regardless of the command encoding.
TEXT	Responses from the instrument are always delimited with <CR> at the beginning and the end of the string, regardless of the command encoding.

To Select a Hessen response mode, press:

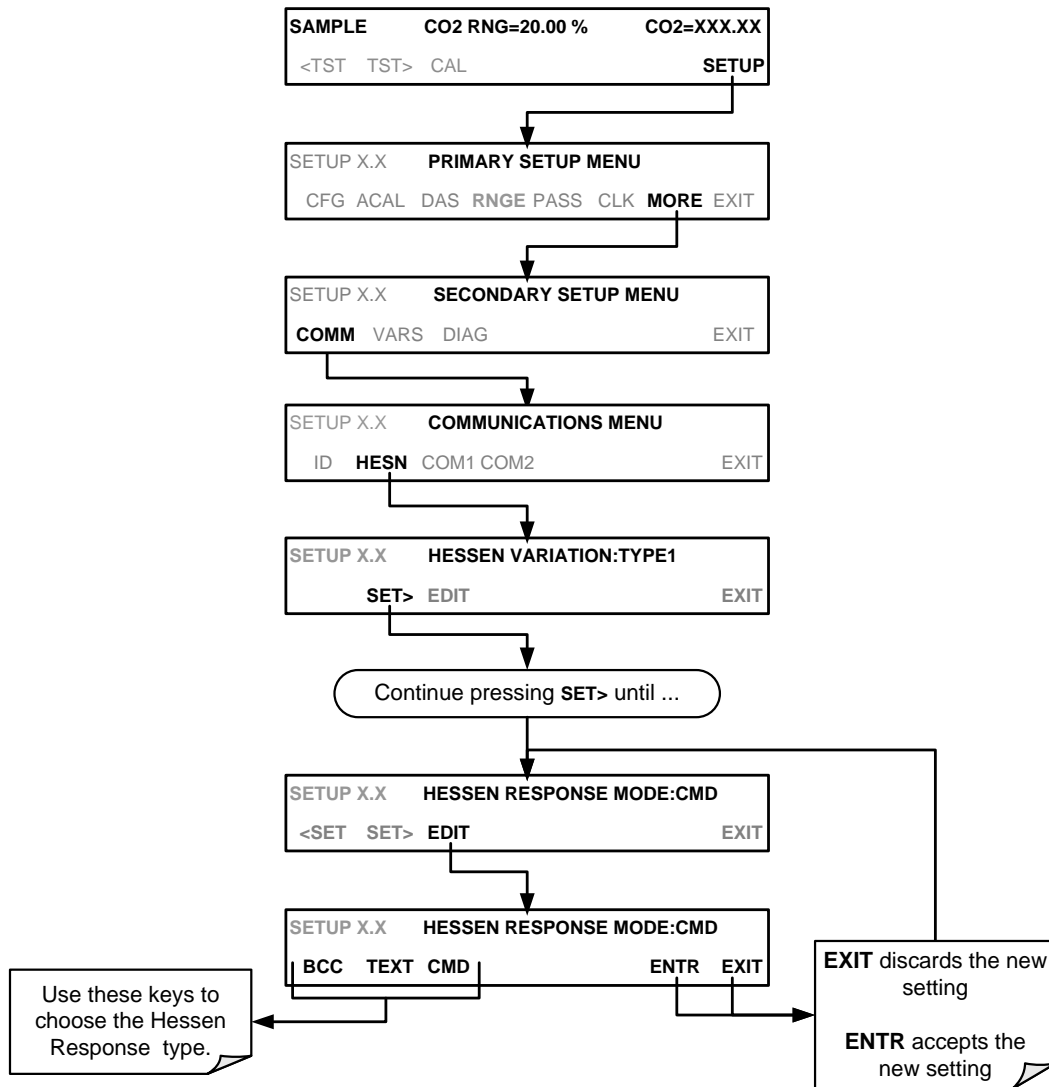

(The ACAL submenu in the Primary Setup Menu is a special configuration; consult factory).

6.5.2.5. GAS LIST ENTRY FORMAT AND DEFINITIONS

The T803 analyzer keeps a list of available gas types. Each entry in this list is of the following format.

[GAS TYPE],[RANGE],[GAS ID],[REPORTED]

WHERE:

GAS TYPE = The type of gas being reported (e.g. O₂, CO₂).

RANGE = The concentration range for this entry in the gas list. This feature permits the user to select which concentration range will be used for this gas list entry. The T803 analyzer has two ranges: **RANGE1** or LOW and **RANGE2** or HIGH (See Section 5.4.1).

0 - The HESSEN protocol to use whatever range is currently active.

1 - The HESSEN protocol will always use **RANGE1** for this gas list entry

2 - The HESSEN protocol will always use **RANGE2** for this gas list entry

3 - Not applicable to the T803 analyzer.

GAS ID = An identification number assigned to a specific gas. In the case of the T803 analyzer in its base configuration, there is only one gas O₂, and its default GAS ID is 110. This ID number should not be modified.

REPORT = States whether this list entry is to be reported or not reported when ever this gas type or instrument is polled by the HESSEN network. If the list entry is not to be reported this field will be blank.

The T803 analyzer measures CO₂ and O₂. The default gas list entries are:

O2, 0, 110, REPORTED

CO2, 0, 111, REPORTED

These default settings cause the instrument to report the concentration value of the currently active range. If you wish to have just concentration value stored for a specific range, this list entry should be edited or additional entries should be added (see Section 6.5.2.6).

EXAMPLE: Changing the above O₂ gas list entry to read:

CO2, 2, 111, REPORTED

would cause only the last CO₂ reading while **RANGE2** (HIGH) range was active to be recorded.

6.5.2.6. EDITING OR ADDING HESSEN GAS LIST ENTRIES

To add or edit an entry to the Hessen Gas List, press:

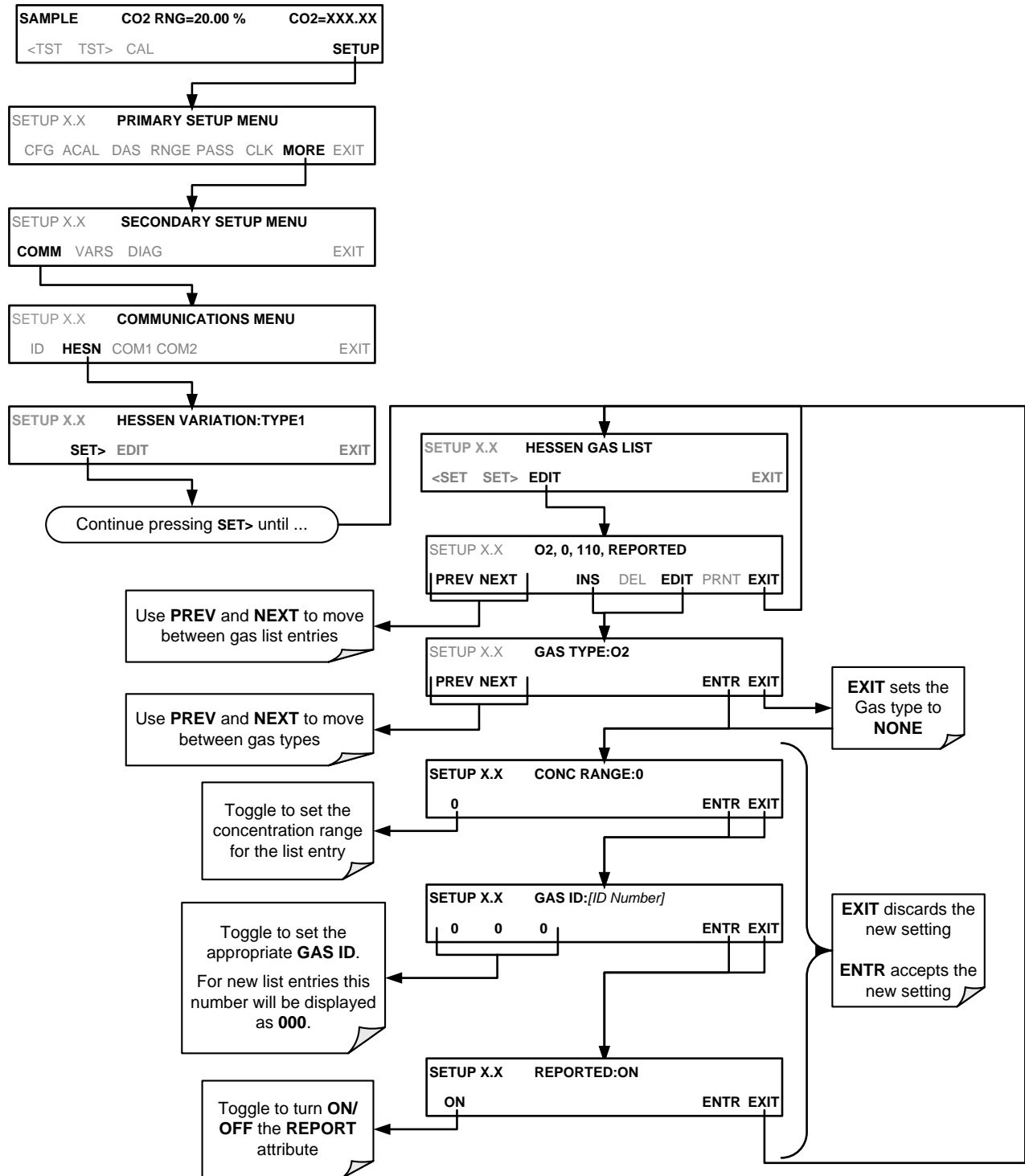

(The ACAL submenu in the Primary Setup Menu is a special configuration; consult factory).

6.5.2.7. DELETING HESSEN GAS LIST ENTRIES

To delete an entry from the Hessen Gas list, press:

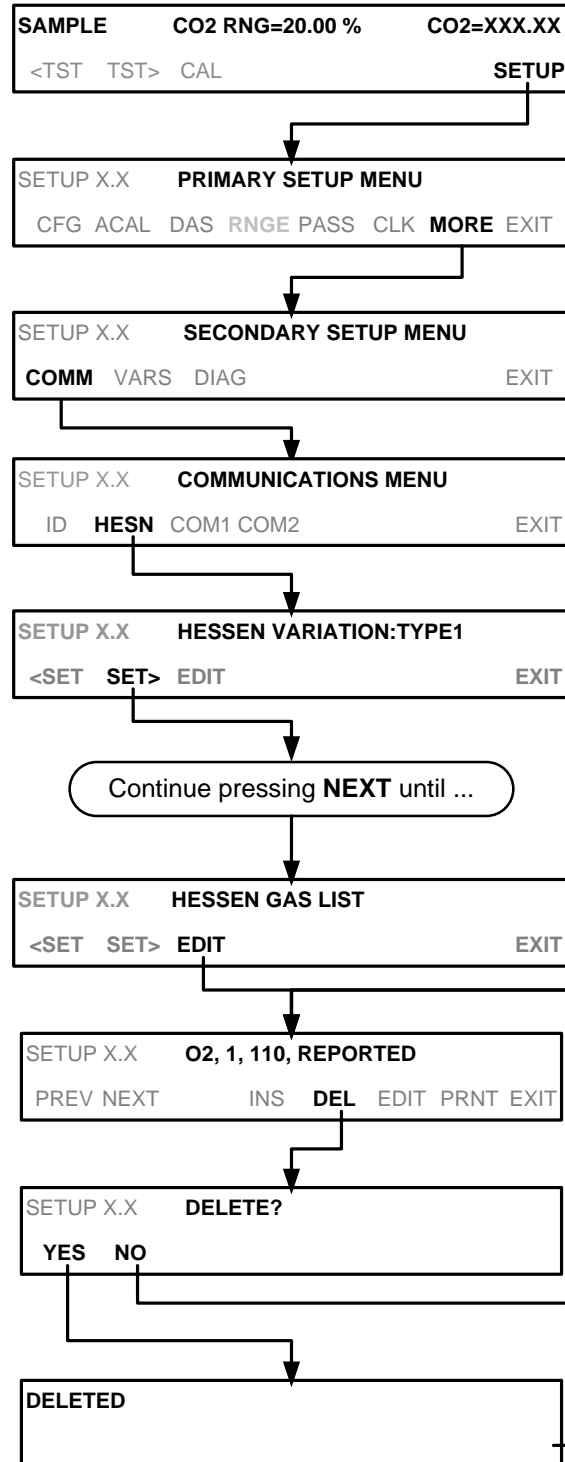

(The ACAL submenu in the Primary Setup Menu is a special configuration; consult factory).

6.5.3. SETTING HESSEN PROTOCOL STATUS FLAGS

Teledyne API's implementation of Hessen protocols includes a set of status bits that the instrument includes in responses to inform the host computer of its condition. Each bit can be assigned to one operational and warning message flag. The default settings for these bit/flags are:

Table 6-6: Default Hessen Status Flag Assignments

STATUS FLAG NAME	DEFAULT BIT ASSIGNMENT
WARNING FLAGS¹	
SAMPLE FLOW WARNING	0001
INVALID CONC (The instrument's front panel display will show the concentration as "Warnings")	0080
OPERATIONAL FLAGS¹	
In MANUAL Calibration Mode	0200
In O ₂ ZERO Calibration Mode ³	0400
In CO ₂ ZERO Calibration Mode ³	0400
In O ₂ SPAN Calibration Mode ³	0800
In CO ₂ SPAN Calibration Mode ³	0800
UNITS OF MEASURE FLAGS⁴	
UGM⁴	0000
MGM⁴	2000
PPB⁴	4000
PPM⁴	6000
SPARE/UNUSED BITS	0001, 0002, 0004, 0008, 0010 0020, 0040, 0100, 1000, 8000
UNASSIGNED FLAGS (0000)	
O2 CELL TEMP WARN	ANALOG CAL WARNING
CO2 CELL TEMP WARN	CAL MP O2
SAMPLE PRESS WARN	CAL MP CO2
RELAY BOARD WARN	REAR BOARD NOT DET
CANNOT DYN SPAN	SYSTEM RESET
CANNOT DYN ZERO	CO2 CONC ALARM 1²
O2 CONC ALARM 1²	CO2 CONC ALARM 2²
O2 CONC ALARM 2²	BOX TEMP WARNING
¹ These status flags are standard for all instruments and should probably not be modified. ² Only applicable if the analyzer is equipped with an alarm option. ³ It is possible to assign more than one flag to the same Hessen status bit. This allows the grouping of similar flags, such as all temperature warnings, under the same status bit. <i>Be careful not to assign conflicting flags to the same bit as each status bit will be triggered if any of the assigned flags is active.</i> ⁴ While these units are assigned flags, they are not applicable in the T803 which reports in %.	

To assign or reset the status flag bit assignments, press:

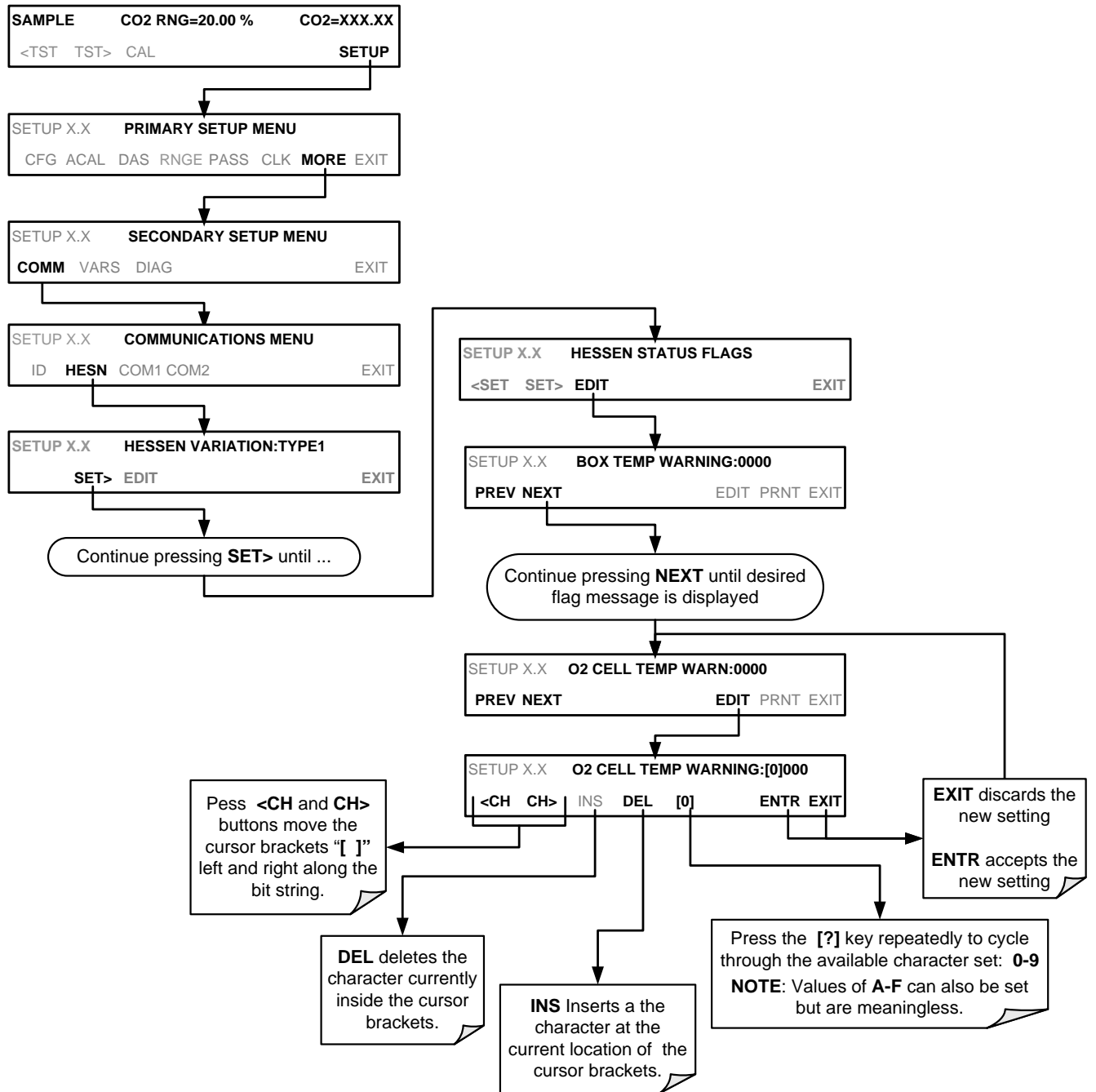

(The ACAL submenu in the Primary Setup Menu is a special configuration; consult factory).

6.5.4. INSTRUMENT ID CODE

Each instrument on a Hessen Protocol network must have a unique ID code. If more than one T803 analyzer is on the Hessen network, you will have to change this code for all but one of the T803 analyzer's on the Hessen network (see Section 6.2.4). The default **ID** code for the T803 analyzers is **803**.

7. DATA ACQUISITION SYSTEM (DAS & APICOM)

The T803 analyzer contains a flexible and powerful, internal data acquisition system (DAS) that enables the analyzer to store concentration and calibration data as well as a host of diagnostic parameters. The DAS of the T803 can store several months of data, depending on how it is configured.. The data are stored in non-volatile memory and are retained even when the instrument is powered off. Data are stored in plain text format for easy retrieval and use in common data analysis programs (such as spreadsheet-type programs).

The DAS is designed to be flexible; users have full control over the type, length and reporting time of the data. The DAS permits users to access stored data through the instrument's front panel or its communication ports.

Note

The DAS can be disabled only by disabling or deleting its individual data channels.

7.1. SETUP → DAS: USING THE DATA ACQUISITION SYSTEM (DAS)

The principal use of the DAS is logging data for trend analysis and predictive diagnostics, which can assist in identifying possible problems before they affect the functionality of the analyzer. The secondary use is for data analysis, documentation and archival in electronic format.

To support the DAS functionality, Teledyne API offers APICOM, a program that provides a visual interface for remote or local setup, configuration and data retrieval of the DAS. The APICOM manual (included with the program), contains a more detailed description of the DAS structure and configuration, which is briefly described here.

The T803 includes a basic DAS configuration, which is enabled by default. New data channels are also enabled by default, but each channel may be turned off for later or occasional use.

IMPORTANT

IMPACT ON READINGS OR DATA

DAS operation is suspended whenever its configuration is edited using the analyzer's front panel and therefore data may be lost. To prevent such data loss, it is recommended to use the APICOM graphical user interface for DAS changes. Please be aware that all stored data will be erased if the analyzer's disk-on-module or CPU board is replaced or if the configuration data stored there is reset..

7.1.1. DAS STATUS

The green SAMPLE LED on the instrument front panel, which indicates the analyzer status, also indicates certain aspects of the DAS status:

Table 7-1: SAMPLE LED Status Indicators for DAS

LED STATE	DAS STATUS
steady off	System is in calibration mode. Data logging can be enabled or disabled for this mode. Calibration data are typically stored at the end of calibration periods, concentration data are typically not sampled, diagnostic data should be collected.
blinking	Instrument is in hold-off mode, a short period after the system exits calibrations. DAS channels can be enabled or disabled for this period. Concentration data are typically disabled whereas diagnostic should be collected.
steady on	Sampling normally.

The DAS can be disabled, as opposed to suspended, only by disabling or deleting its individual data channels.

7.1.2. DAS STRUCTURE

The DAS is designed around the feature of a “record”. A record is a single data point. The type of data recorded in a record is defined by two properties:

- **PARAMETER** type that defines the kind of data to be stored (e.g. the average of gas concentrations measured with three digits of precision). See Section 7.1.5.3.
- A **TRIGGER** event that defines when the record is made (e.g. timer; every time a calibration is performed, etc.). See Section 7.1.5.2.

The specific **PARAMETER** and **TRIGGER** events that describe an individual record are defined in a construct called a **DATA CHANNEL** (see Section 7.1.3). Each data channel relates one or more parameters with a specific trigger event and various other operational characteristics related to the records being made (e.g., the channel’s name, number of records to be made, time period between records, whether or not the record is exported via the analyzer’s RS-232 port, etc.).

The number of DAS objects are limited by the instrument’s finite storage capacity. For information regarding the maximum number of channels, parameters, and records and how to calculate the file size for each data channel, refer to the DAS manual downloadable from the TAPI website at <http://www.teledyne-api.com/manuals/>, under Special Manuals.

7.1.2.1. DAS CHANNELS

The key to the flexibility of the DAS is its ability to store a large number of combinations of triggering events and data parameters in the form of data channels. Users may create up to 50 data channels and each channel can contain one or more parameters. For each channel, the following are selected:

- One triggering event is selected
- Up to 50 data parameters, which can be shared between channels.
- Several other properties that define the structure of the channel and allow the user to make operational decisions regarding the channel.

Table 7-2: DAS Data Channel Properties

PROPERTY	DESCRIPTION	DEFAULT SETTING	SETTING RANGE
NAME	The name of the data channel.	"NONE"	Up to 6 letters or digits ¹ .
TRIGGERING EVENT	The event that triggers the data channel to measure and store the datum	ATIMER	Any available event (see Appendix A-5).
NUMBER AND LIST OF PARAMETERS	A User-configurable list of data types to be recorded in any given channel.	1 (PMTDET)	Any available parameter (see Appendix A-5).
REPORT PERIOD	The amount of time between each channel data point.	000:01:00 (1 hour)	000:00:01 to 366:23:59 (Days:Hours:Minutes)
NUMBER OF RECORDS	The number of reports that will be stored in the data file. Once the limit is exceeded, the oldest data is over-written.	100	Configuration-dependent, limited by available storage space.
RS-232 REPORT	Enables the analyzer to automatically report channel values to the RS-232 ports.	OFF	OFF or ON
CHANNEL ENABLED	Enables or disables the channel. Allows a channel to be temporarily turned off without deleting it.	ON	OFF or ON
CAL HOLD OFF	Disables sampling of data parameters while instrument is in calibration mode ² .	OFF	OFF or ON
¹ More with APICOM, but only the first six are displayed on the front panel). ² When enabled records are not recorded until the DAS HOLDOFF period is passed after calibration mode. DAS HOLDOFF SET in the VAR S menu (see Section 5.5.)			

7.1.3. DEFAULT DAS CHANNELS

CONC: Samples CO₂ and O₂ concentrations at one-minute intervals and stores an average every five minutes with a time and date stamp. Readings during calibration and calibration **HOLD OFF** are not included in the data..

PNUMTC: Collects sample flow and sample pressure data at five-minute intervals and stores an average once a day with a time and date stamp. This data is useful for monitoring the condition of the pump and critical flow orifice (sample flow) and the sample filter (clogging indicated by a drop in sample pressure) over time to predict when maintenance will be required. The last 360 daily averages (about 1 year) are stored.

CALDAT: Data channels log new slopes and offsets of measurements each time an O₂ zero or span calibration is performed and the result changes the value of the slope (triggering event: **SLPCHG**). Although there is a separate data channel for CO₂ (**CALCO2**), this channel could be configured to include both O₂ and CO₂.

- This data channel will store data from the last 200 calibrations and can be used to document analyzer calibration; it also is useful for detecting trends in slope and offset (instrument response) when performing predictive diagnostics as part of a regular maintenance schedule.
- The CALDAT channel collects data based on events (e.g. a calibration operation) rather than a timed interval and therefore does not represent any specific length of time. As with all data channels, a date and time stamp is recorded for every logged data point.

CALCO2: Same as for CALDAT above, but this channel is configured to log data for CO₂.

DETAILED: Samples seven different parameters related to the operating status of the analyzer's. For each parameter:

- A value is logged once every minute;
- An average of the last 60 readings is calculated once every minute.
- The last 480 averages are stored (20 days).

This channel is useful for diagnosing problems that cause the instruments measurements to drift slowly over time

FAST: Almost identical to **DETAILED** except that for each parameter:

- Samples are taken once per minute and reported once per minute, in effect causing the instrument to record an instantaneous reading of each parameter every minute.
- The last 360 readings for each parameter are recorded/reported.

This channel is useful for diagnosing transients; spikes and noise problems.

These default Data Channels can be used as they are, or they can be customized from the front panel to fit a specific application. They can also be deleted to make room for custom user-programmed Data Channels.

Appendix A-5 lists the firmware-specific DAS configuration in plain-text format. This text file either can be loaded into APICOM and then modified and uploaded to the instrument, or can be copied and pasted into a terminal program to be sent to the analyzer.

IMPORTANT**IMPACT ON READINGS OR DATA**

Sending a DAS configuration to the analyzer through its COM ports will replace the existing configuration and will delete all stored data. Back up any existing data and the DAS configuration before uploading new settings.

Triggering Events and Data Parameters/Functions for these default channels are:

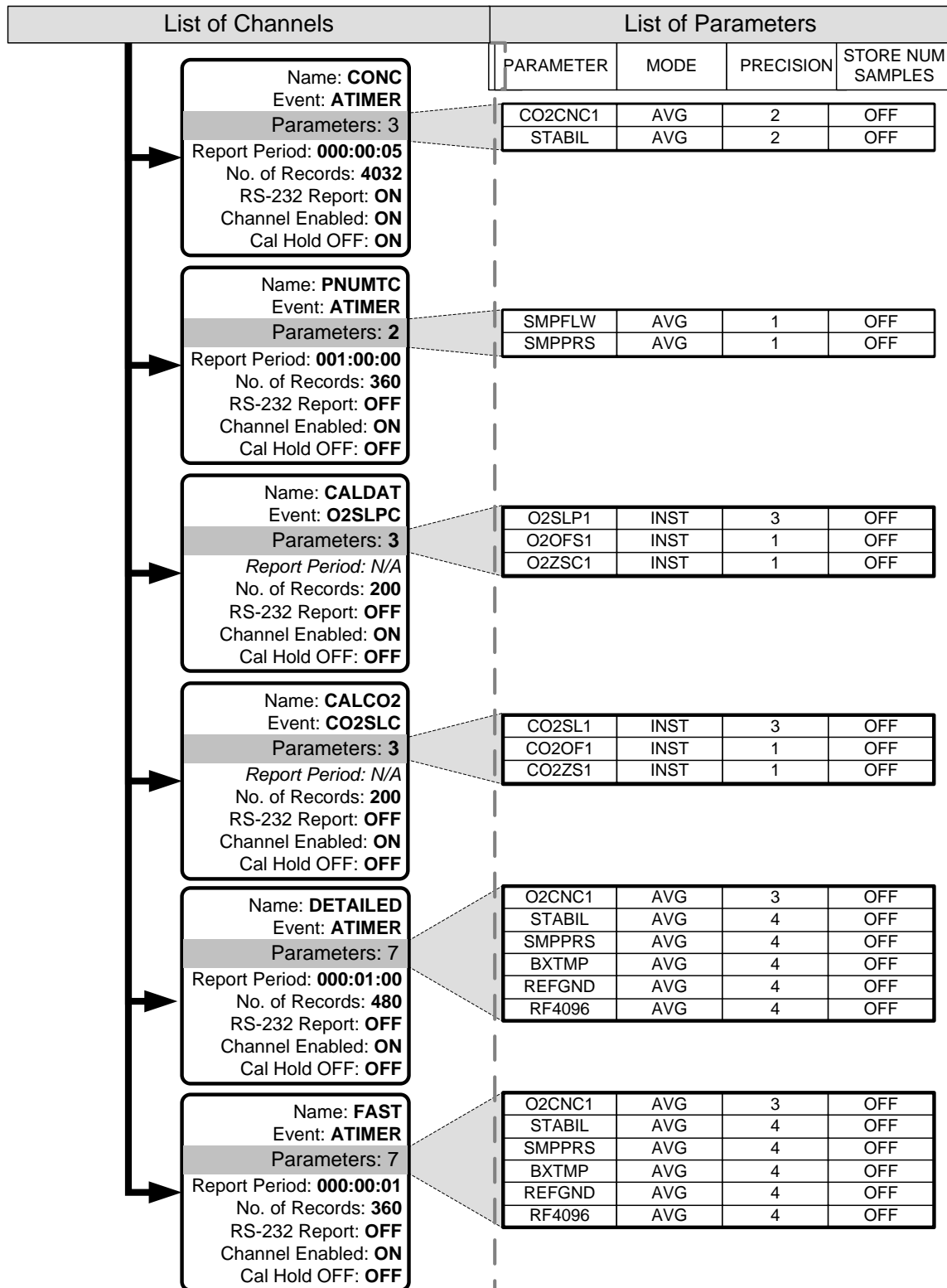
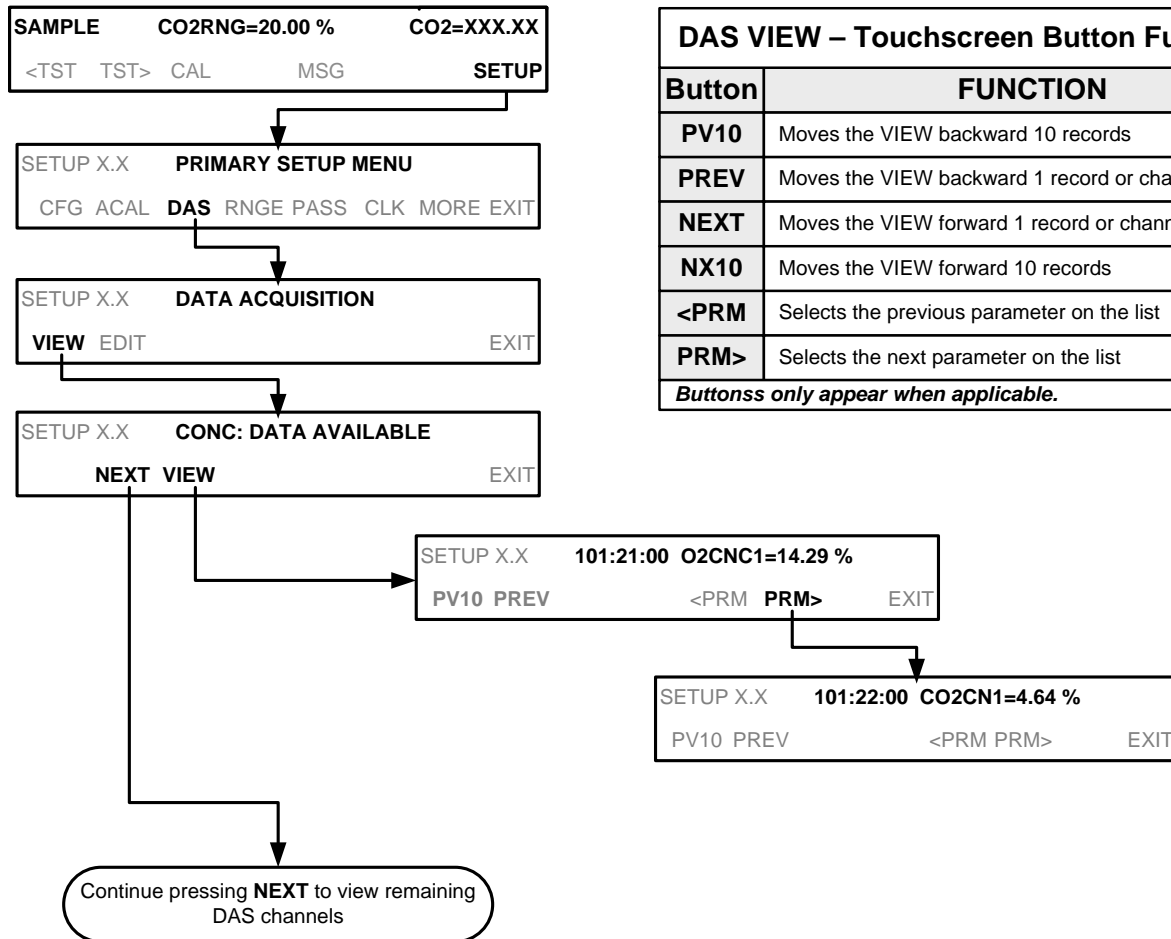

Figure 7-1: Default DAS Channel Setup

7.1.4. SETUP →DAS →VIEW: VIEWING DAS CHANNELS AND INDIVIDUAL RECORDS

DAS data and settings can be viewed on the front panel display through the following touchscreen button sequence:



DAS VIEW – Touchscreen Button Functions	
Button	FUNCTION
PV10	Moves the VIEW backward 10 records
PREV	Moves the VIEW backward 1 record or channel
NEXT	Moves the VIEW forward 1 record or channel
NX10	Moves the VIEW forward 10 records
<PRM	Selects the previous parameter on the list
PRM>	Selects the next parameter on the list
<i>Buttons only appear when applicable.</i>	

(The ACAL submenu in the Primary Setup Menu is a special configuration; consult factory).

7.1.5. SETUP →DAS →EDIT: ACCESSING THE DAS EDIT MODE

DAS configuration is most conveniently done through the APICOM remote control program. The following list of touchscreen buttons shows how to edit using the front panel.

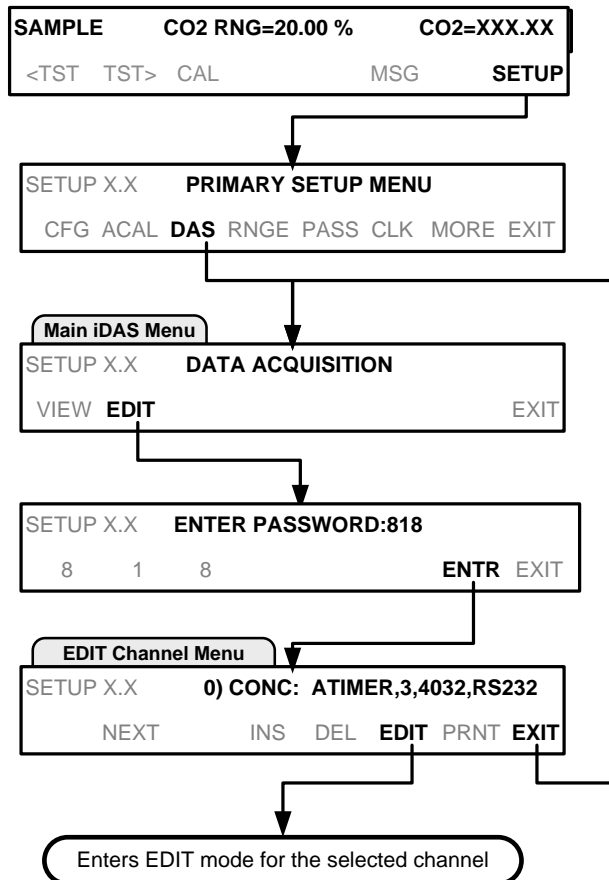

DAS EDIT – Touchscreen Button Functions	
Button	FUNCTION
PREV	Selects the previous data channel in the list
NEXT	Selects the next data channel in the list
INS	Inserts a new data channel into the list BEFORE the selected channel
DEL	Deletes the currently selected data channel
EDIT	Enters EDIT mode
PRINT	Exports the configuration of all data channels to the RS-232 interface
<i>Buttons only appear when applicable</i>	

When editing the data channels, the Param field of the display indicates some of the DAS configuration parameters.

For example, the display line, **0) CONC: ATIMER, 3, 4032, RS232**, translates to the following configuration:

0	Channel No.
CONC	Channel Name
ATIMER	Trigger Event
3	Parameters – number of parameters included in this channel
4032	Event – number of data points this channel is set up to store
RS232	Port via which values automatically reported

7.1.5.1. EDITING DAS DATA CHANNEL NAMES

To edit the name of a DAS data channel, follow the instruction shown in Section 7.1.5 then press:

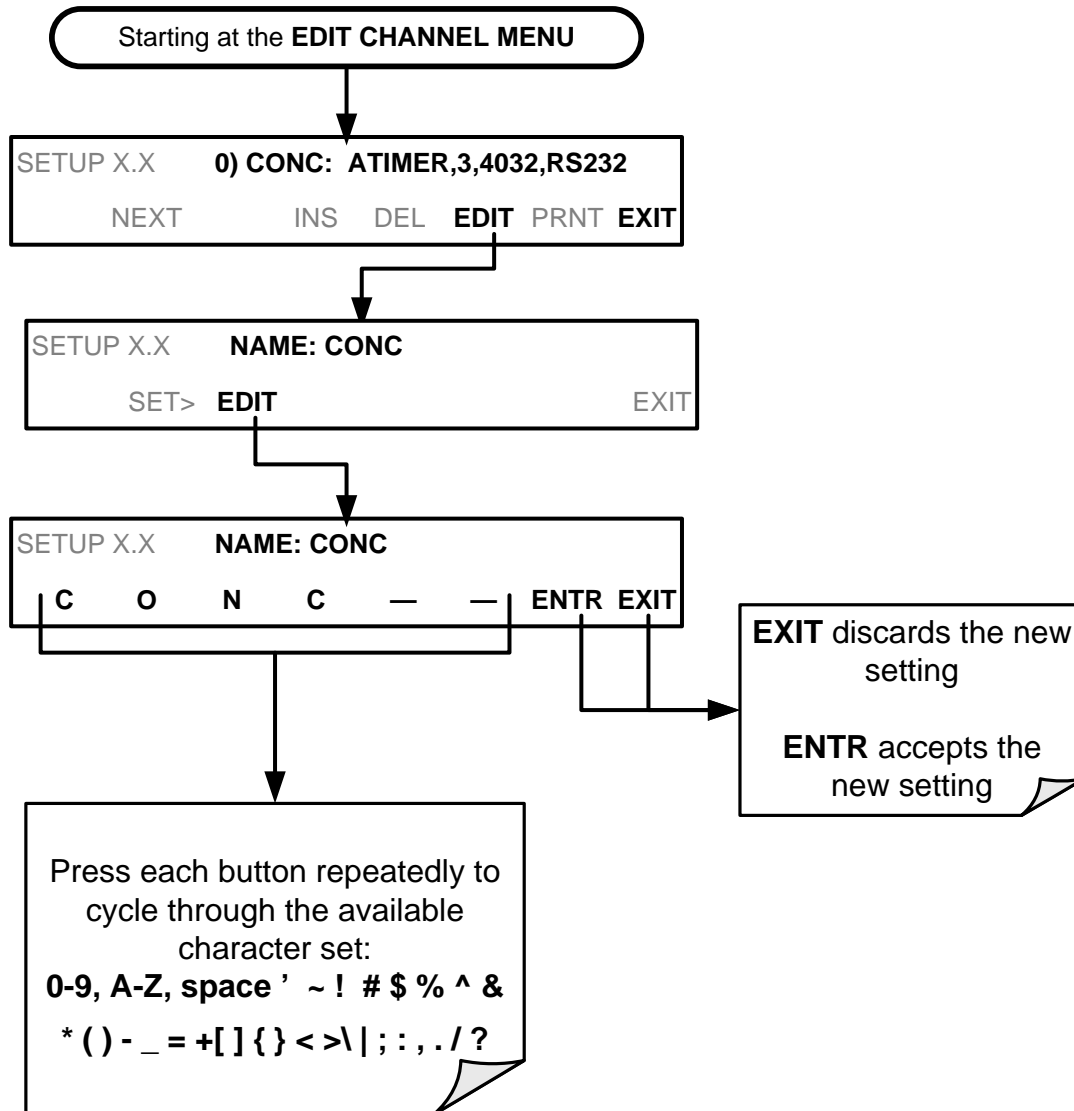

7.1.5.2. EDITING DAS TRIGGERING EVENTS

Triggering events define when and how the DAS records a measurement of any given data channel. The most commonly used triggering events are:

ATIMER: Sampling at regular intervals specified by an automatic timer. Most trending information is usually stored at such regular intervals, which can be instantaneous or averaged.

EXO2ZR, EXO2SP, EXO2MP, O2SLPC (exit O₂ zero, exit O₂ span, O₂ slope change); **EXCO2Z, EXCO2S, EXCO2M, CO2SLC** (exit CO₂ zero, exit CO₂ span, CO₂ slope change); **:** Sampling at the end of (irregularly occurring) calibrations or when the response slope changes. These triggering events create

instantaneous data points, e.g., for the new slope and offset (concentration response) values at the end of a calibration. Zero and slope values are valuable to monitor response drift and to document when the instrument was calibrated.

WARNINGS: Some data may be useful when stored if one of several warning messages appears such as **CO2TMW**, **O2TMPW** (CO₂ or O₂ sensor temperature warning). This is helpful for trouble-shooting by monitoring when a particular warning occurred.

To edit the list of data parameters associated with a specific data channel, follow the instruction shown in Section 7.1.5 then press:

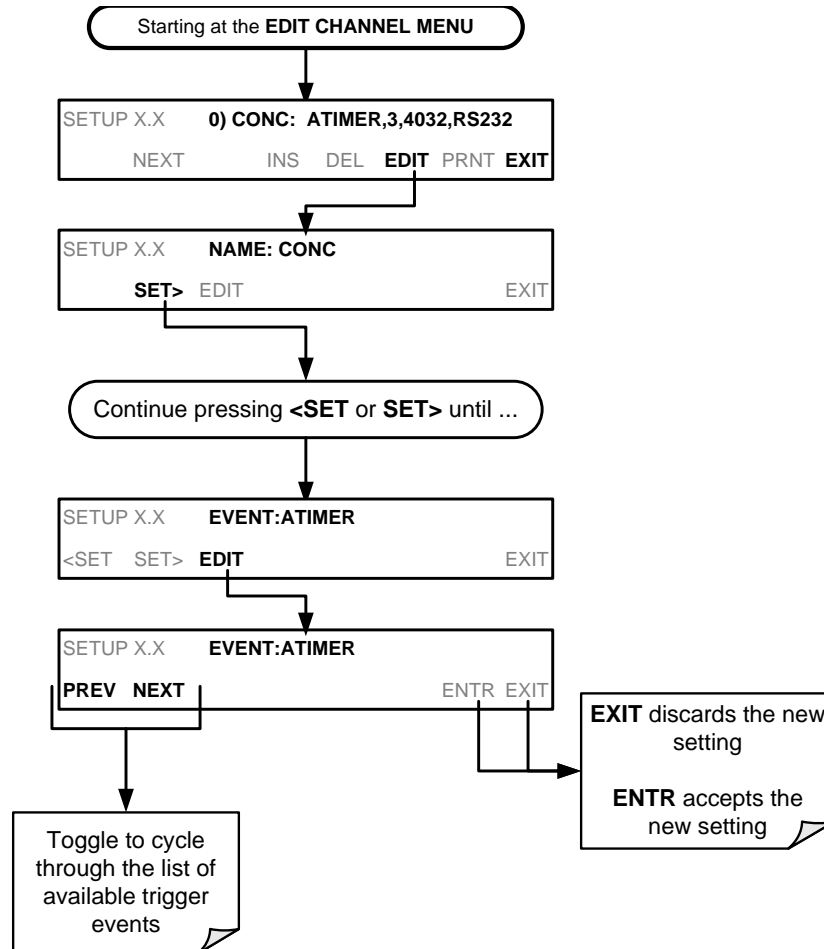

Note

DAS Trigger Events are firmware specific; a list of trigger events can be found in Appendix A-5 of this manual.

7.1.5.3. EDITING DAS PARAMETERS

Data parameters are types of data that may be measured and stored by the DAS. For each Teledyne API analyzer model, the list of available data parameters is different, fully defined and not customizable. Appendix A-5 lists firmware specific data parameters for the T803. DAS parameters include things like CO₂

concentration measurements, temperatures of the various heaters placed around the analyzer, pressures and flows of the pneumatic subsystem and other diagnostic measurements as well as calibration data such as stability, slope and offset.

Most data parameters have associated measurement units, such as mV, ppb, cm³/min, etc., although some parameters have no units (e.g. **SLOPE**). With the exception of concentration readings, none of these units of measure can be changed.

Note

DAS does not keep track of the units (i.e. %) of each concentration value; therefore, DAS data files may contain concentrations data recorded in more than one type of unit if the units of measure was changed during data acquisition.

Each data parameter has user-configurable functions that define how the data are recorded:

Table 7-3: DAS Data Parameter Functions

FUNCTION	EFFECT
PARAMETER	Instrument-specific parameter name.
SAMPLE MODE	INST: Records instantaneous reading. AVG: Records average reading during reporting interval. SDEV: Records the standard deviation of the data points recorded during the reporting interval. MIN: Records minimum (instantaneous) reading during reporting interval. MAX: Records maximum (instantaneous) reading during reporting interval.
PRECISION	0 to 4: Sets the number of digits to the right decimal point for each record. Example: Setting 4; “ 399.9865 % ” Setting 0; “ 400 % ”
STORE NUM. SAMPLES	OFF: Stores only the average (default). ON: Stores the average and the number of samples used to compute the value of the parameter. This property is only useful when the AVG sample mode is used. Note that the number of samples is the same for all parameters in one channel and needs to be specified only for one of the parameters in that channel.

Users can build a channel by selecting desired parameters from the available choices.

Data channels can be edited individually from the front panel without affecting other data channels. However, when editing a data channel, such as during adding, deleting or changing parameters, all data for that particular channel will be lost, because the DAS can store only data of one format (number of parameter columns etc.) for any given channel. In addition, a DAS configuration can only be uploaded remotely as an entire set of channels. Hence, remote update of the DAS will always delete all current channels and stored data.

To modify, add or delete a parameter, follow the instruction shown in Section 7.1.5 then press:

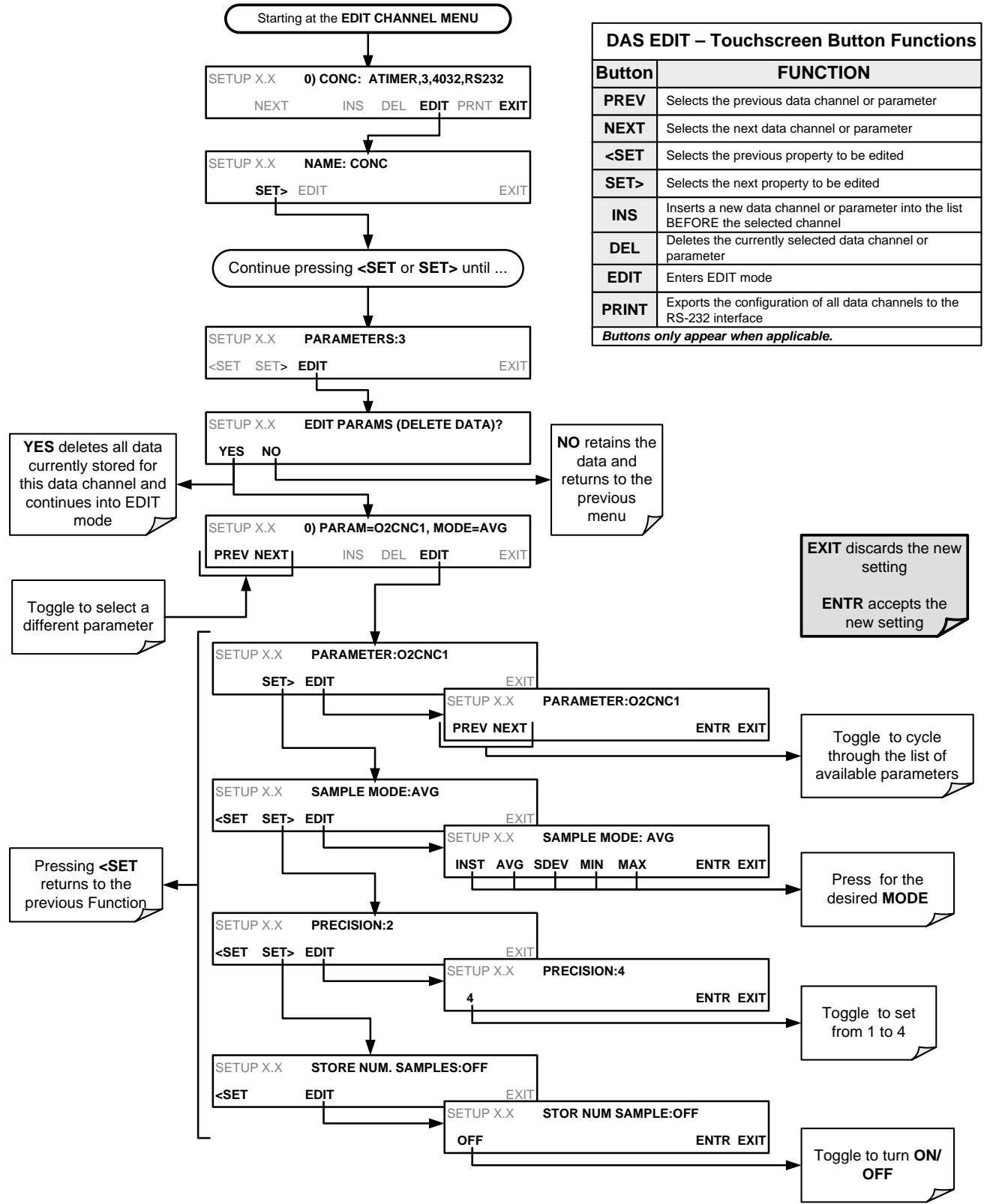

Note

When the STORE NUM SAMPLES feature is turned on, the instrument will store the number of measurements that were used to compute the AVG, SDEV, MIN or MAX value but not the actual measurements themselves.

7.1.5.4. EDITING SAMPLE PERIOD AND REPORT PERIOD

The DAS defines two principal time periods by which sample readings are taken and permanently recorded:

SAMPLE PERIOD: Determines how often DAS temporarily records a sample reading of the parameter in volatile memory. **SAMPLE PERIOD** is only used when the DAS parameter's sample mode is set for **AVG, SDEV, MIN** or **MAX**

The **SAMPLE PERIOD** is set to one minute by default and generally cannot be accessed from the standard DAS front panel menu, but is available via the instrument's communication ports by using APICOM or the analyzer's standard serial data protocol.

REPORT PERIOD: Sets how often the sample readings stored in volatile memory are processed, (e.g. average, minimum or maximum are calculated); the results stored permanently in the instrument's Disk-on-Module as well as transmitted via the analyzer's communication ports. The Report Period may be set from the front panel. If the **INST** sample mode is selected, the instrument stores and reports an instantaneous reading of the selected parameter at the end of the chosen report period.

To define the **REPORT PERIOD**, follow the instruction shown in Section 7.1.5 then press:

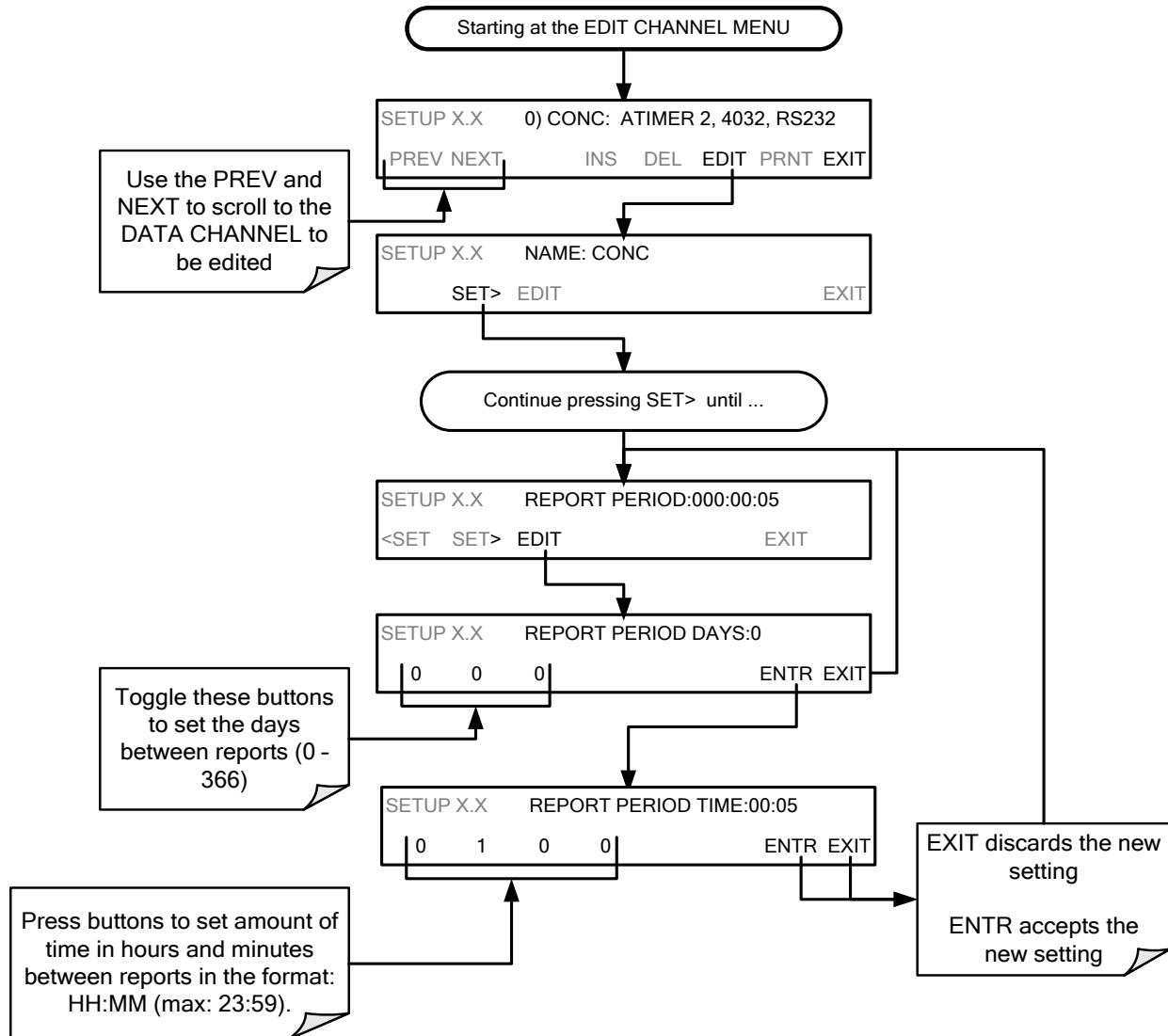

The **SAMPLE PERIOD** and **REPORT PERIOD** intervals are synchronized to the beginning and end of the appropriate interval of the instrument's internal clock.

If **SAMPLE** Period were set for one minute, the first reading would occur at the beginning of the next full minute according to the instrument's internal clock.

If the Report period were set for one hour, the first report activity would occur at the beginning of the next full hour according to the instrument's internal clock.

EXAMPLE:

Given the above settings, if DAS were activated at 7:57:35 the first sample would occur at 7:58 and the first report would be calculated at 8:00 consisting of data points for 7:58, 7:59 and 8:00. During the next hour (from 8:01 to 9:00), the instrument will take a sample reading every minute and include 60 sample readings.

7.1.5.5. REPORT PERIODS IN PROGRESS WHEN INSTRUMENT IS POWERED OFF

If the instrument is powered off in the middle of a **REPORT PERIOD**, the samples accumulated so far during that period are lost. Once the instrument is turned back on, the DAS begins taking samples and temporarily storing them in volatile memory as part of a new **REPORT PERIOD**. At the end of this **REPORT PERIOD**, only the sample readings taken since the instrument was turned back on will be included in any **AVG**, **SDEV**, **MIN** or **MAX** calculation.

Also, the **STORE NUM SAMPLE** feature will report the number of sample readings taken since the instrument was restarted.

7.1.5.6. EDITING THE NUMBER OF RECORDS

The number of data records in the DAS is cumulative across all channels and parameters, filling about one megabyte of space on the disk-on-module; this means that the actual number of records is limited by the total number of parameters and channels and other settings in the DAS configuration. Every additional data channel (up to 20), parameter (up to 50 per channel), number of samples setting etc. will govern the maximum amount of data points.

The DAS will check the amount of available data space and prevent the user from specifying too many records at any given point. If, for example, the DAS memory space can accommodate 375 more data records, the **ENTR** button will disappear when trying to specify more than that number of records. This check for memory space may also make an upload of a DAS configuration with APICOM or a terminal program fail, if the combined number of records would be exceeded. In this case, it is suggested to either try to determine what the maximum number of records available is using the front panel interface or use trial-and-error in designing the DAS script or calculate the number of records using the DAS or APICOM manuals.

To set the **NUMBER OF RECORDS**, follow the instruction shown in Section 7.1.5 then press:

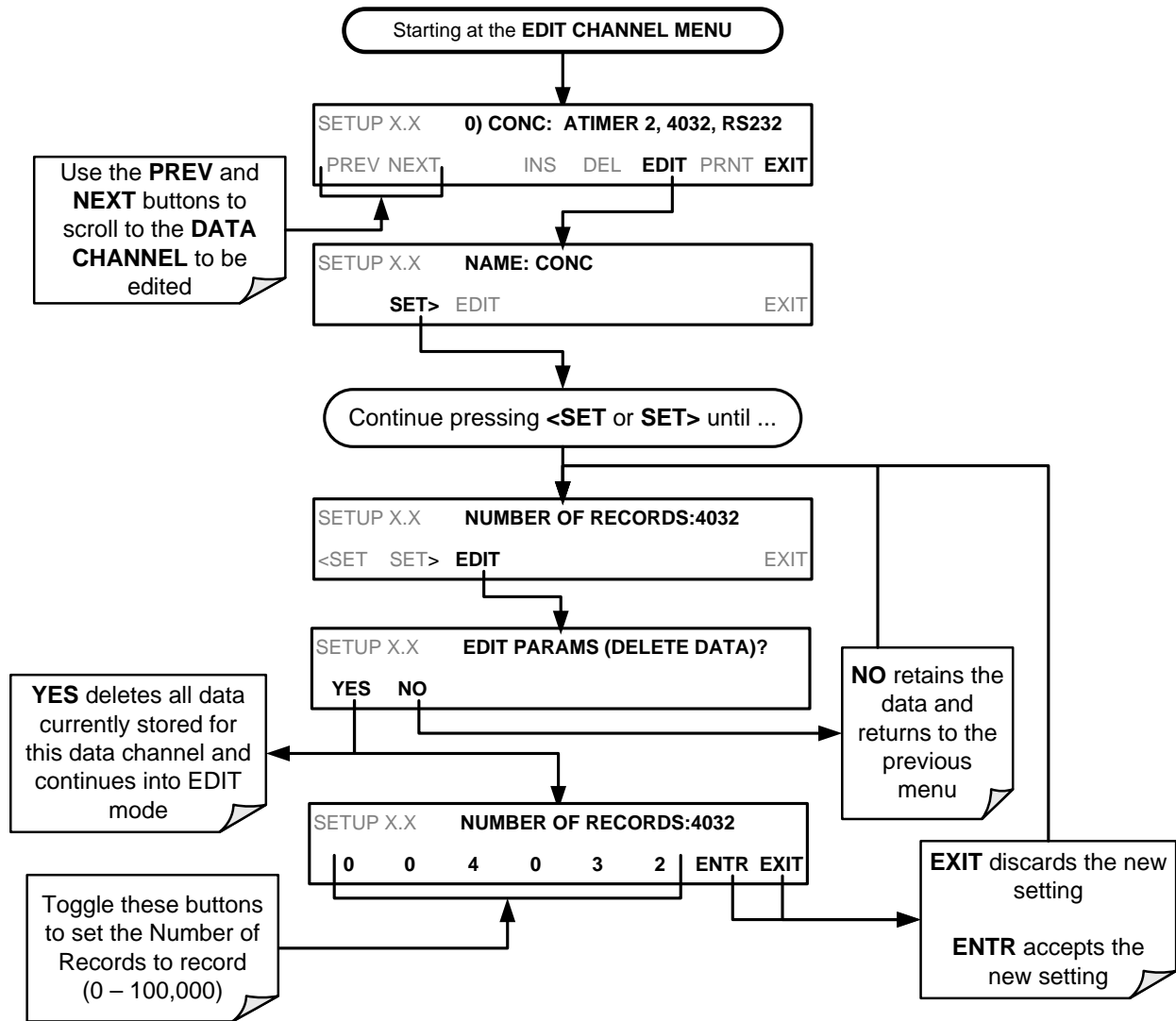

7.1.5.7. RS-232 REPORT FUNCTION

The DAS can automatically report data to the communications ports, where they can be captured with a terminal emulation program or simply viewed by the user using the APICOM software.

To enable automatic **COM** port reporting, follow the instruction shown in Section 7.1.5 then press:

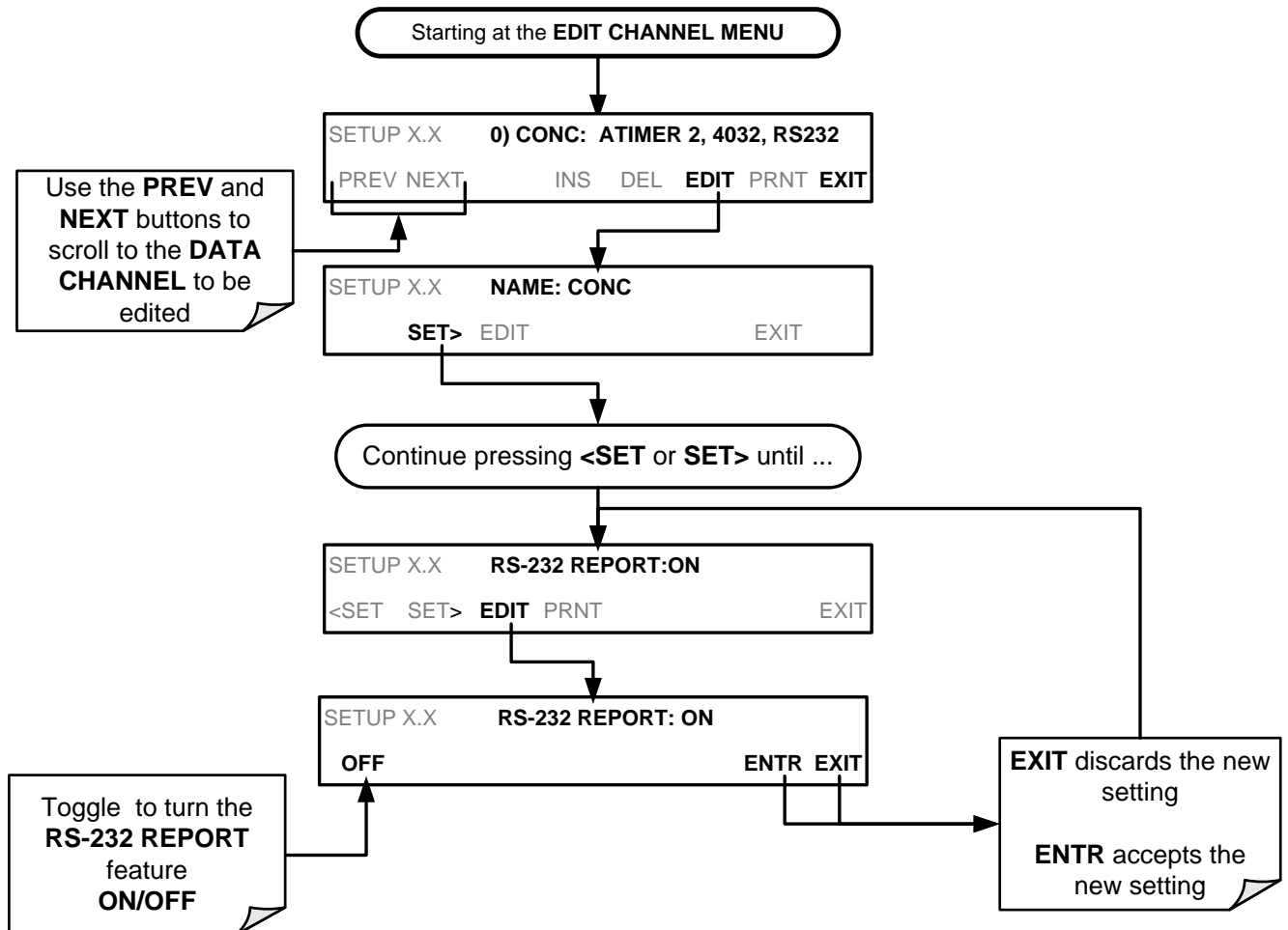

7.1.5.8. ENABLING / DISABLING THE HOLD OFF FEATURE

The DAS **HOLD OFF** feature prevents data collection during calibration operations.

To enable or disable the **HOLD OFF**, follow the instruction shown in Section 7.1.5 then press:

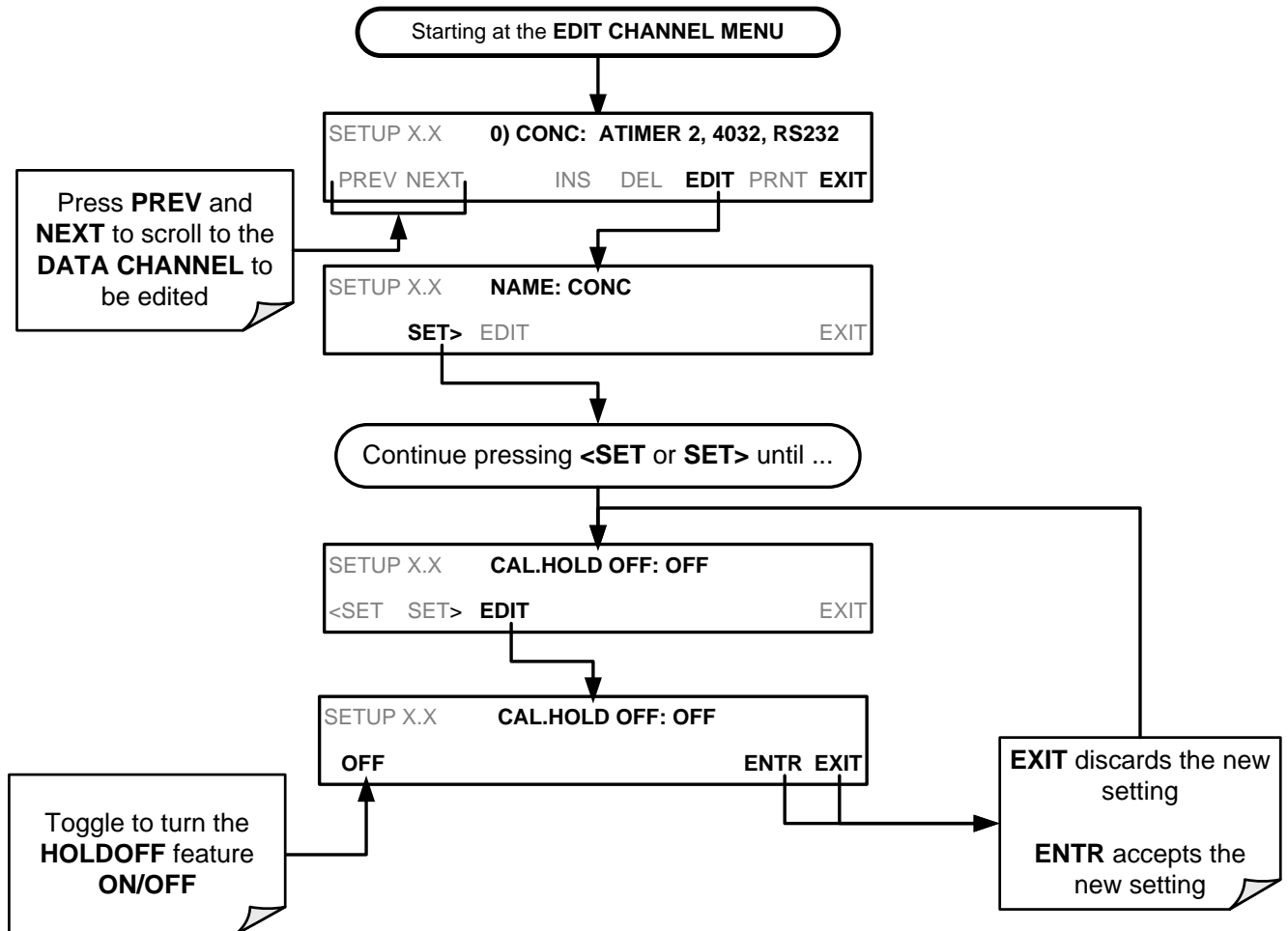

HOLD OFF also prevents DAS measurements from being made at certain times when the quality of the analyzer's O₂ measurements may be suspect (e.g. while the instrument is warming up). In this case, the length of time that the **HOLD OFF** feature is active, is determined by the value of the internal variable (**VAR5**), **DAS_HOLD OFF**.

To set the length of the **DAS_HOLD OFF** period, see Section 11.1.3.

7.1.5.9. THE COMPACT REPORT FEATURE

When enabled, this option avoids unnecessary line breaks on all RS-232 reports. Instead of reporting each parameter in one channel on a separate line, up to five parameters are reported in one line.

The **COMPACT DATA REPORT** generally cannot be accessed from the standard DAS front panel menu, but is available via the instrument's communication ports by using APICOM or the analyzer's standard serial data protocol.

7.1.5.10. THE STARTING DATE FEATURE

This option allows specifying a starting date for any given channel when the user wants to start data acquisition only after a certain time and date. If the **STARTING DATE** is in the past (the default condition), the DAS ignores this setting and begins recording data as defined by the **REPORT PERIOD** setting.

The **STARTING DATE** generally cannot be accessed from the standard DAS front panel menu, but is available via the instrument's communication ports by using APICOM or the analyzer's standard serial data protocol.

7.1.6. DISABLING/ENABLING DATA CHANNELS

Data channels can be temporarily disabled, which can reduce the read/write wear on the disk-on-module.

To disable a data channel, follow the instruction shown in Section 7.1.5 then press:

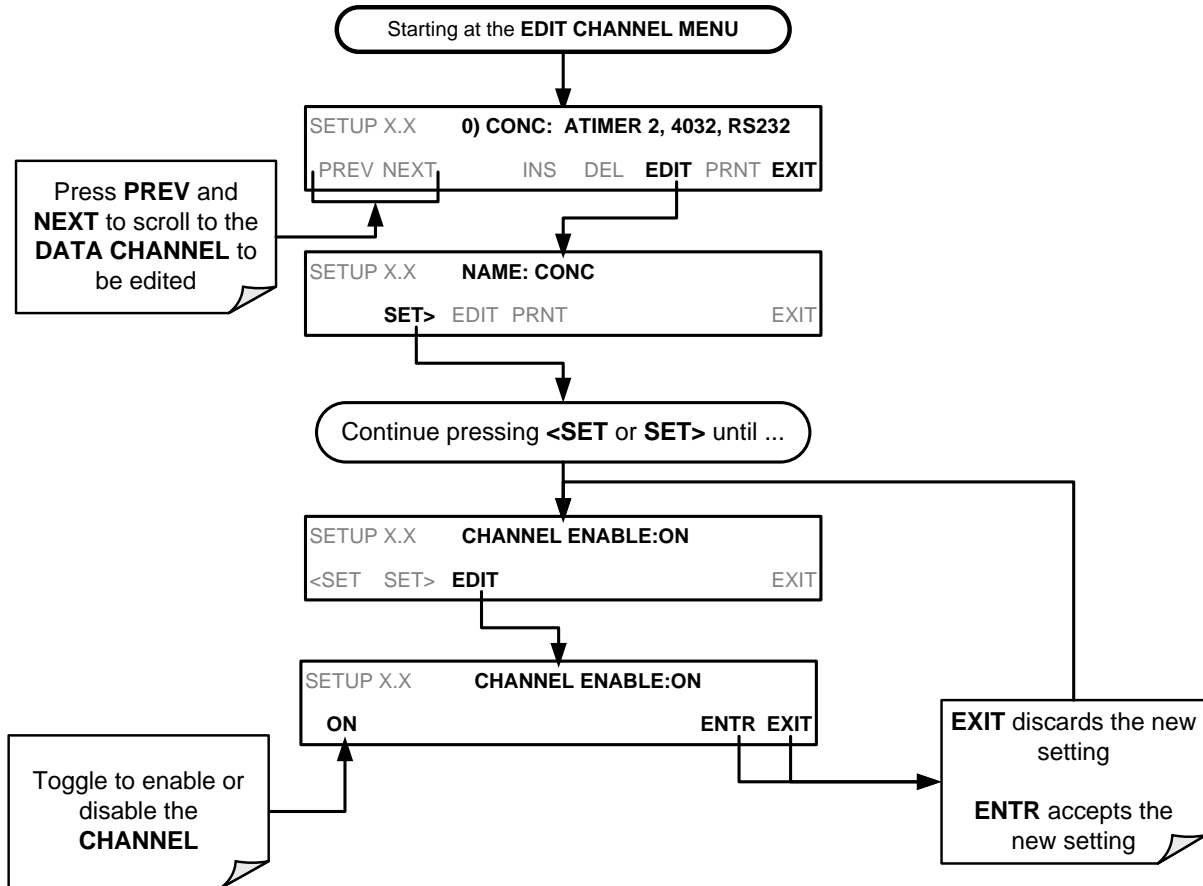

7.2. REMOTE DAS CONFIGURATION

The DAS can be configured and operated remotely via either the APICOM interface or a terminal emulation program. (Refer to Section 8 of this manual for details on remote operation of the T803 analyzer).

7.2.1. DAS CONFIGURATION VIA APICOM

Editing channels, parameters and triggering events as described herein, can be performed via the APICOM remote control program using the graphic interface shown below. Refer to Section 8 of this manual for details on remote operation of the T803 analyzer.

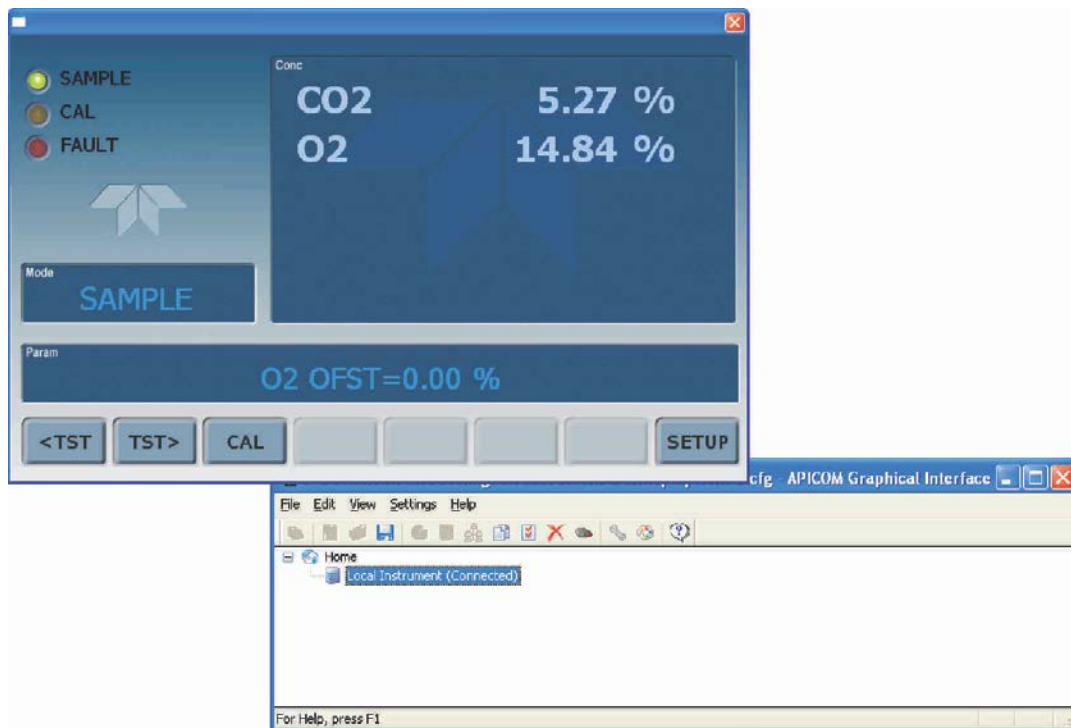

Figure 7-2: APICOM Remote Control Program Interface

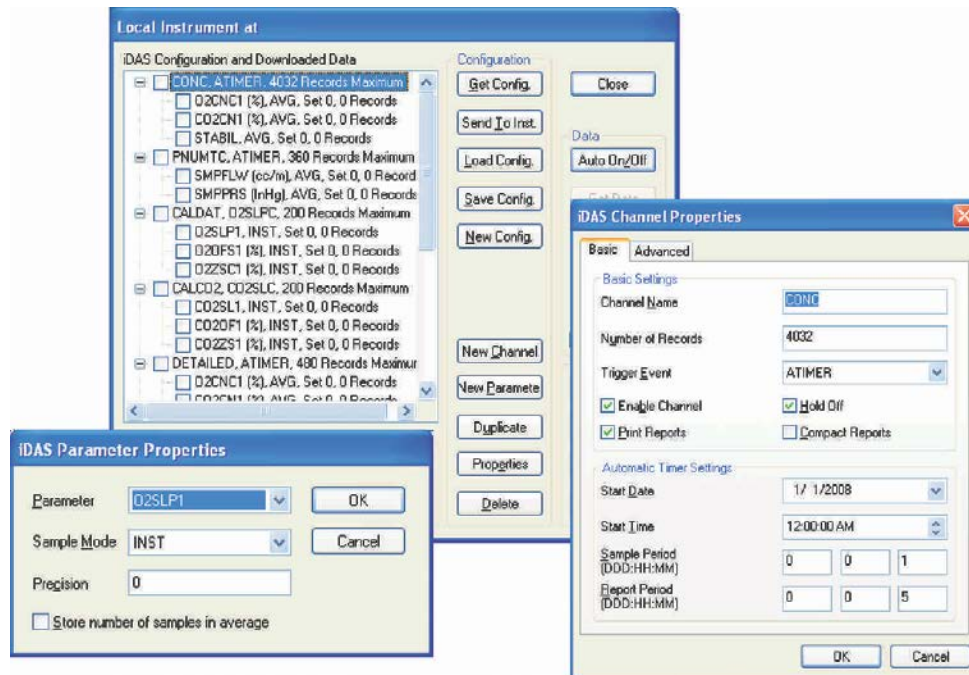

Figure 7-3: APICOM User Interface for Configuring the DAS

Once a DAS configuration is created, it is conveniently saved to your computer and can be uploaded to any instrument; it can be stored on a computer for later review, alteration or documentation and archival. Refer to the APICOM manual for details on these procedures. The APICOM user manual (Teledyne API PN 058130000) is included in the APICOM installation file, which can be downloaded at <http://www.teledyne-api.com/manuals/>.

This page intentionally left blank.

8. REMOTE OPERATION

This section provides information needed when using external digital and serial I/O for remote operation. It assumes that the electrical connections have been made as described in Section 3.3.1.

Your analyzer can be remotely configured, calibrated or queried for stored data through the serial ports, via either **Computer mode** (using a personal computer) or **Interactive mode** (using a terminal emulation program).

8.1. COMPUTER MODE

Computer Mode is used when the analyzer is connected to a computer with a dedicated interface program such as APICOM.

8.1.1. REMOTE CONTROL VIA APICOM

APICOM is an easy-to-use, yet powerful interface program that allows the user to access and control any of Teledyne API's main line of ambient and stack-gas instruments from a remote connection through direct cable, modem or Ethernet. Running APICOM, a user can:

- Establish a link from a remote location to the T803 through direct cable connection via RS-232 modem or Ethernet.
- View the instrument's front panel and remotely access all functions that could be accessed when standing in front of the instrument.
- Remotely edit system parameters and set points.
- Download, view, graph and save data for predictive diagnostics or data analysis.
- Check on system parameters for trouble-shooting and quality control.

APICOM is very helpful for initial setup, data analysis, maintenance, and troubleshooting. Figure 7-2 shows examples of APICOM's main interface, which emulates the look and functionality of the instruments actual front panel. APICOM is included free of cost with the analyzer and the latest versions can also be downloaded at <http://www.teledyne-api.com/software/>.

8.2. INTERACTIVE MODE

Interactive mode is used with a terminal emulation program such as HyperTerminal or a “dumb” computer terminal.

8.2.1.1. HELP COMMANDS IN INTERACTIVE MODE

Table 8-1: Terminal Mode Software Commands

COMMAND	Function
Control-T	Switches the analyzer to terminal mode (echo, edit). If mode flags 1 & 2 are OFF, the interface can be used in interactive mode with a terminal emulation program.
Control-C	Switches the analyzer to computer mode (no echo, no edit).
CR (carriage return)	A carriage return is required after each command line is typed into the terminal/computer. The command will not be sent to the analyzer to be executed until this is done. On personal computers, this is achieved by pressing the ENTER button.
BS (backspace)	Erases one character to the left of the cursor location.
ESC (escape)	Erases the entire command line.
?[ID] CR	This command prints a complete list of available commands along with the definitions of their functionality to the display device of the terminal or computer being used. The ID number of the analyzer is only necessary if multiple analyzers are on the same communications line, such as the multi-drop setup.
Control-P	Restarts the listing of commands.

8.2.1.2. COMMAND SYNTAX

Commands are not case-sensitive, and all arguments within one command (i.e. ID numbers, keywords, data values, etc.) must be separated with a space character.

All Commands follow the syntax:

X [ID] COMMAND <CR>

Where

- X** is the command type (one letter; refer to Table 8-2) that defines the type of command. Allowed designators are listed in Appendix A-6.
- [ID]** is the machine identification number (Section 6.2.4). Example: the Command “? 803” followed by a carriage return would print the list of available commands for the revision of software currently installed in the instrument assigned ID Number 803.

COMMAND is the command designator: This string is the name of the command being issued (LIST, ABORT, NAME, EXIT, etc.). Some commands may have additional arguments that define how the command is to be executed. Press ? <CR> or refer to Appendix A-6 for a list of available command designators

<CR> is a carriage return. All commands must be terminated by a carriage return (usually achieved by pressing the ENTER button on a computer).

Table 8-2: Teledyne API Serial I/O Command Types

COMMAND	COMMAND TYPE
C	Calibration
D	Diagnostic
L	Logon
T	Test measurement
V	Variable
W	Warning

8.2.1.3. DATA TYPES

Data types consist of integers, hexadecimal integers, floating-point numbers, Boolean expressions and text strings.

Integer data: Used to indicate integral quantities such as a number of records, a filter length, etc.

- They consist of an optional plus or minus sign, followed by one or more digits.
- For example, +1, -12, 123 are all valid integers.

Hexadecimal integer data: Used for the same purposes as integers.

- They consist of the two characters "0x," followed by one or more hexadecimal digits (0-9, A-F, a-f), which is the 'C' programming language convention.
- No plus or minus sign is permitted.
- For example, 0x1, 0x12, 0x1234abcd are all valid hexadecimal integers.

Floating-point number: Used to specify continuously variable values such as temperature set points, time intervals, warning limits, voltages, etc.

- They consist of an optional plus or minus sign, followed by zero or more digits, an optional decimal point and zero or more digits.
- At least one digit must appear before or after the decimal point.
- Scientific notation is not permitted.
- For example, +1.0, 1234.5678, -0.1, 1 are all valid floating-point numbers.

Boolean expressions: Used to specify the value of variables or I/O signals that may assume only two values.

- They are denoted by the keywords **ON** and **OFF**.

Text strings: Used to represent data that cannot be easily represented by other data types, such as data channel names, which may contain letters and numbers.

- They consist of a quotation mark, followed by one or more printable characters, including spaces, letters, numbers, and symbols, and a final quotation mark.
- For example, "a", "1", "123abc", and "()[]<>" are all valid text strings.
- It is not possible to include a quotation mark character within a text string.

Some commands allow you to access variables, messages, and other items. When using these commands, you must type the entire name of the item; you cannot abbreviate any names.

8.2.1.4. STATUS REPORTING

Reporting of status messages as an audit trail is one of the three principal uses for the RS-232 interface (the other two being the command line interface for controlling the instrument and the download of data in electronic format). You can effectively disable the reporting feature by setting the interface to quiet mode (Section 6.2.1, Table 6-1).

Status reports include warning messages, calibration and diagnostic status messages. Refer to Appendix A-3 for a list of the possible messages.

8.2.1.5. GENERAL MESSAGE FORMAT

All messages from the instrument (including those in response to a command line request) are in the format:

X DDD:HH:MM [Id] MESSAGE<CRLF>

Where:

X is a command type designator, a single character indicating the message type, as shown in the Table 8-2.

DDD:HH:MM is the time stamp, the date and time when the message was issued. It consists of the Day-of-year (DDD) as a number from 1 to 366, the hour of the day (HH) as a number from 00 to 23, and the minute (MM) as a number from 00 to 59.

[ID] is the analyzer ID, a number with 1 to 4 digits.

MESSAGE is the message content that may contain warning messages, test measurements, variable values, etc.

<CRLF> is a carriage return line feed pair, which terminates the message.

The uniform nature of the output messages makes it easy for a host computer to parse them into an easy structure. Keep in mind that the front panel display does not give any information on the time a message was issued, hence it is useful to log such messages for trouble-shooting and reference purposes. Terminal emulation programs such as HyperTerminal can capture these messages to text files for later review.

8.2.1.6. COM PORT PASSWORD SECURITY

In order to provide security for remote access of the T803, a **LOGON** feature can be enabled to require a password before the instrument will accept commands. This is done by turning on the **SECURITY MODE** (Mode 4, Section 6.2.1).

Once the **SECURITY MODE** is enabled, the following items apply.

- A password is required before the port will respond or pass on commands.
- If the port is inactive for one hour, it will automatically logoff, which can also be achieved with the LOGOFF command.
- Three unsuccessful attempts to log on with an incorrect password will cause subsequent logins to be disabled for 1 hour, even if the correct password is used.
- If not logged on, the only active command is the '?' request for the help screen.
- The following messages will be returned at logon:
 - LOGON SUCCESSFUL - Correct password given
 - LOGON FAILED - Password not given or incorrect
 - LOGOFF SUCCESSFUL - Connection terminated successfully

To log on to the T803 analyzer with **SECURITY MODE** feature enabled, type:

LOGON 940331

Note

940331 is the default password.

To change the default password, use the variable RS-232_PASS issued as follows:

V RS-232_PASS=NNNNNN

Where N is any numeral between 0 and 9.

8.3. REMOTE ACCESS BY MODEM

The T803 can be connected to a modem for remote access. This requires a cable between the analyzer's COM port and the modem, typically a DB-9F to DB-25M cable (available from Teledyne API with PN WR0000024).

Once the cable has been connected, check to make sure:

- The DTE-DCE switch on the rear panel is in the DCE position.
- The T803 COM port is set for a baud rate that is compatible with the modem,
- The Modem is designed to operate with an 8-bit word length with one stop bit.
- The MODEM ENABLE communication mode is turned on (Mode 64, see Section 6.2.1).

Once this is completed, the appropriate setup command line for your modem can be entered into the analyzer. The default setting for this feature is

AT Y0 &D0 &H0 &I0 S0=2 &B0 &N6 &M0 E0 Q1 &W0

This string can be altered to match your modem's initialization and can be up to 100 characters long.

To change this setting press:

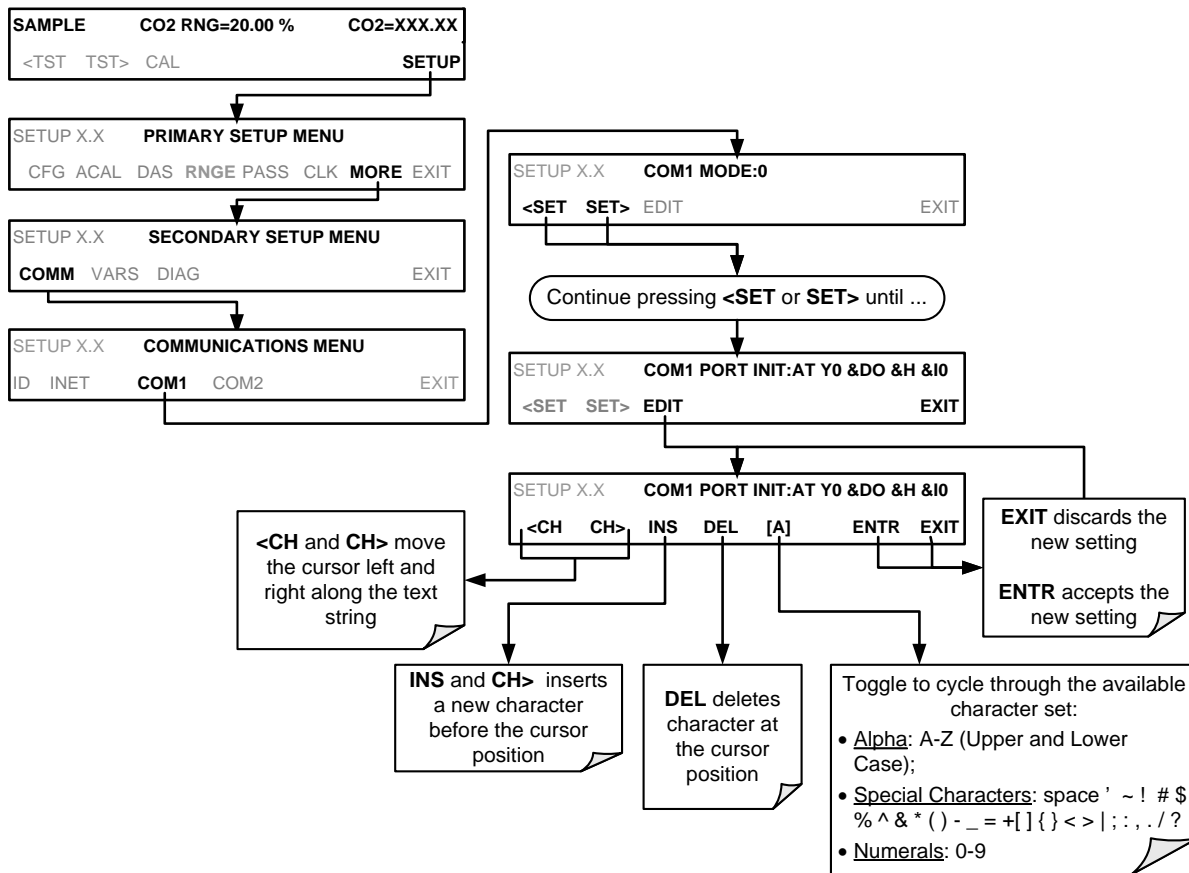

(The ACAL submenu in the Primary Setup Menu is a special configuration; consult factory).

To initialize the modem press:

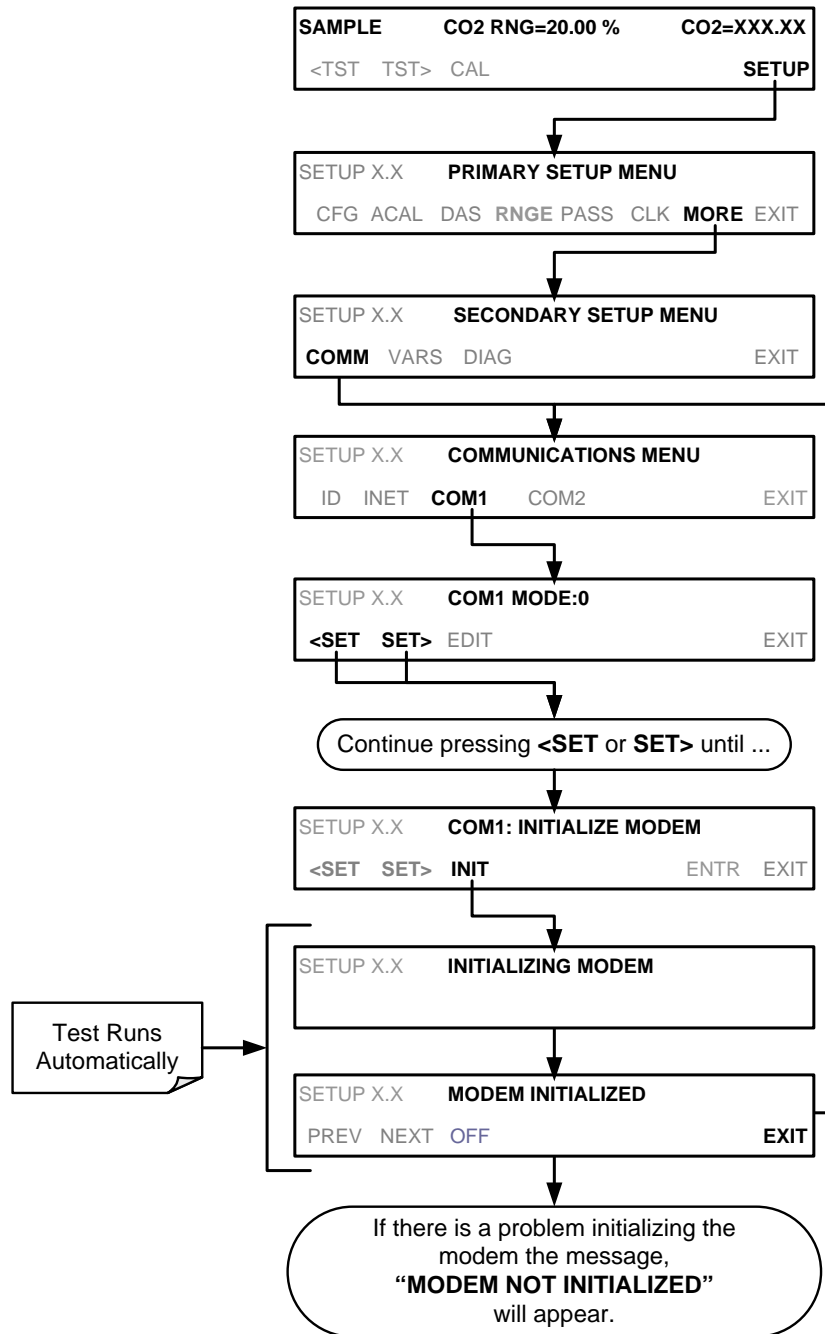

(The ACAL submenu in the Primary Setup Menu is a special configuration; consult factory).

This page intentionally left blank.

9. CALIBRATION PROCEDURES

This section contains a variety of information regarding the various methods for calibrating a T803 as well as other supporting information

This section is organized as follows:

Section 9.1 – Before Calibration

This section contains general information you should know before calibrating the analyzer.

SECTION 9.2 – Manual Calibration Checks and Calibration of the T803 Analyzer

This section describes the procedure for checking the calibration of the T803 and calibrating the instrument. Also included are instructions for selecting the reporting range to be calibrated when the T803 analyzer is set to operate in either the DUAL or AUTO reporting range modes.

SECTION 9.3 – Assessing Calibration Quality

This section describes how to judge the effectiveness of a recently performed calibration.

SECTION 9.4 – Calibration of the T803's Electronic Subsystems

This section describes how to perform calibrations of the T803's electronic systems, including:

- adjusting the analyzers internal flow sensor
- adjusting the analyzers internal pressure sensor

Note

Throughout this Section are various diagrams showing pneumatic connections between this instrument and various other pieces of equipment such as calibrators and zero air sources. These diagrams are only intended to be schematic representations of these connections and do not reflect actual physical locations of equipment and fitting location or orientation. Contact your regional EPA or other appropriate governing agency for more detailed recommendations..

9.1. BEFORE CALIBRATION

The calibration procedures in this section assume that the range mode, analog range and units of measure have already been selected for the analyzer. If this has not been done, please do so before continuing (see Section 5.2 for instructions).

Note

If any problems occur while performing the following calibration procedures, refer to Section 11 for troubleshooting tips.

9.1.1. REQUIRED EQUIPMENT, SUPPLIES, AND EXPENDABLES

Calibration of the T803 analyzer requires a certain amount of equipment and supplies. These include, but are not limited to, the following:

- Zero-air source.
- Span gas source.
- Gas lines - All Gas lines should be Stainless Steel, PTFE (Teflon), glass or electroless nickel.
- A recording device such as a strip-chart recorder and/or data logger (optional). For electronic documentation, the internal data acquisition system can be used.

9.1.2. CALIBRATION GASES

9.1.2.1. ZERO AIR

A gas that is similar in chemical composition to the earth's atmosphere but scrubbed of all components that might affect the analyzer's readings. Teledyne API recommends using pure N₂ when calibrating the zero point of your CO₂ or O₂ sensor except if known interferences are involved (please refer to Section 3.3.2.4).



CAUTION GENERAL SAFETY HAZARD

DO NOT vent calibration gases into enclosed areas. Rapid release of pure N₂ gas into an enclosed space can displace oxygen, and therefore represents an asphyxiation hazard. This may happen with few warning symptoms.

9.1.2.2. SPAN GAS

A gas specifically mixed to match the chemical composition of the type of gas being measured at near full scale of the desired measurement range. In this case, O₂ measurements made with the T803 analyzer, Teledyne API recommends using 21% O₂ in N₂ when calibrating the span point of the O₂ sensor and 16% CO₂ in N₂ when calibrating the span point of the CO₂ sensor..

Cylinders of both calibrated O₂ and CO₂ gas traceable to NIST-Standard Reference Material specifications (also referred to as SRMs or EPA protocol calibration gases) are commercially available.

Table 9-1: NIST SRM's Available for Traceability of O₂ Calibration Gases

NIST-SRM	Type	Nominal Concentration
2657a	O ₂ in N ₂	2%
2658a	O ₂ in N ₂	10 %
2659a	O ₂ in N ₂	21%
2619a	CO ₂ in N ₂	0.5%
2620a	CO ₂ in N ₂	1%
2622a	CO ₂ in N ₂	2%
2624a	CO ₂ in N ₂	3%
2744b	CO ₂ in N ₂	7%
2745 ¹	CO ₂ in N ₂	16%

Note

For span point calibration it is generally a good idea to use 80% of the reporting range for that channel. For instance, if the reporting range of the instrument is set for 5%, the proper span gas would be 4%.

9.1.3. DATA RECORDING DEVICES

A strip chart recorder, data acquisition system or digital data acquisition system should be used to record data from the serial or analog outputs of the T803.

- If analog readings are used, the response of the recording system should be checked against a NIST traceable voltage source or meter.
- Data recording devices should be capable of bi-polar operation so that negative readings can be recorded.
- For electronic data recording, the T803 provides an internal data acquisition system (DAS), which is described in detail in Section 7.1

APICOM, a remote control program, is also provided as a convenient and powerful tool for data handling, download, storage, quick check and plotting (see Section 8.1.1).

9.2. MANUAL CALIBRATION CHECKS AND CALIBRATION OF THE T803 ANALYZER

IMPORTANT

IMPACT ON READINGS OR DATA

ZERO/SPAN CALIBRATION CHECKS VS. ZERO/SPAN CALIBRATION

Pressing the ENTR button during the following procedure resets the stored values for OFFSET and SLOPE and alters the instrument's Calibration. This should **ONLY BE DONE** during an actual calibration of the T803.

NEVER press the ENTR button if you are only *checking* calibration.

9.2.1. SETUP FOR CALIBRATION CHECKS AND CALIBRATION

Connect the Sources of Zero Air and Span Gas as shown below.

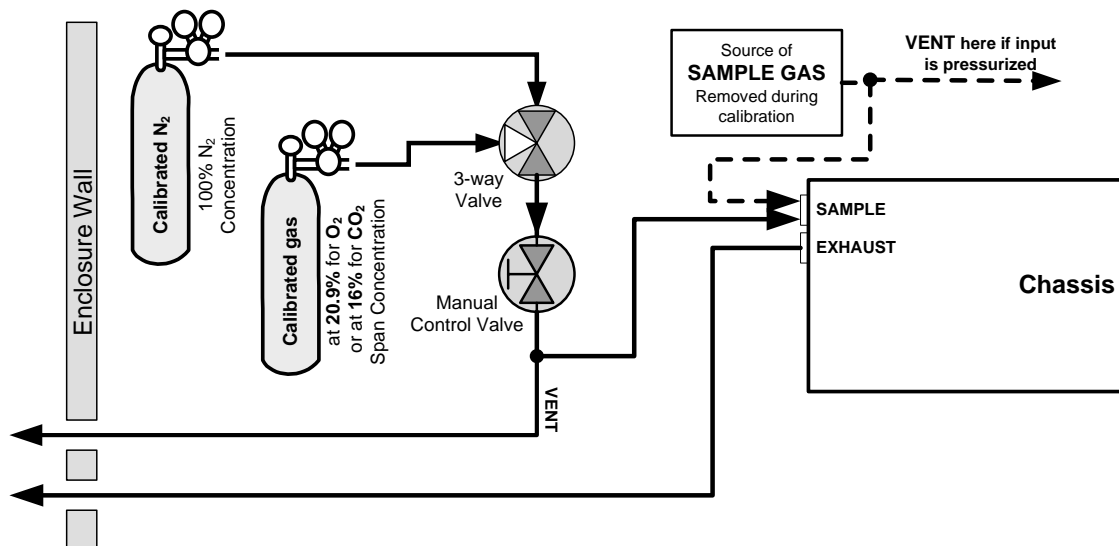
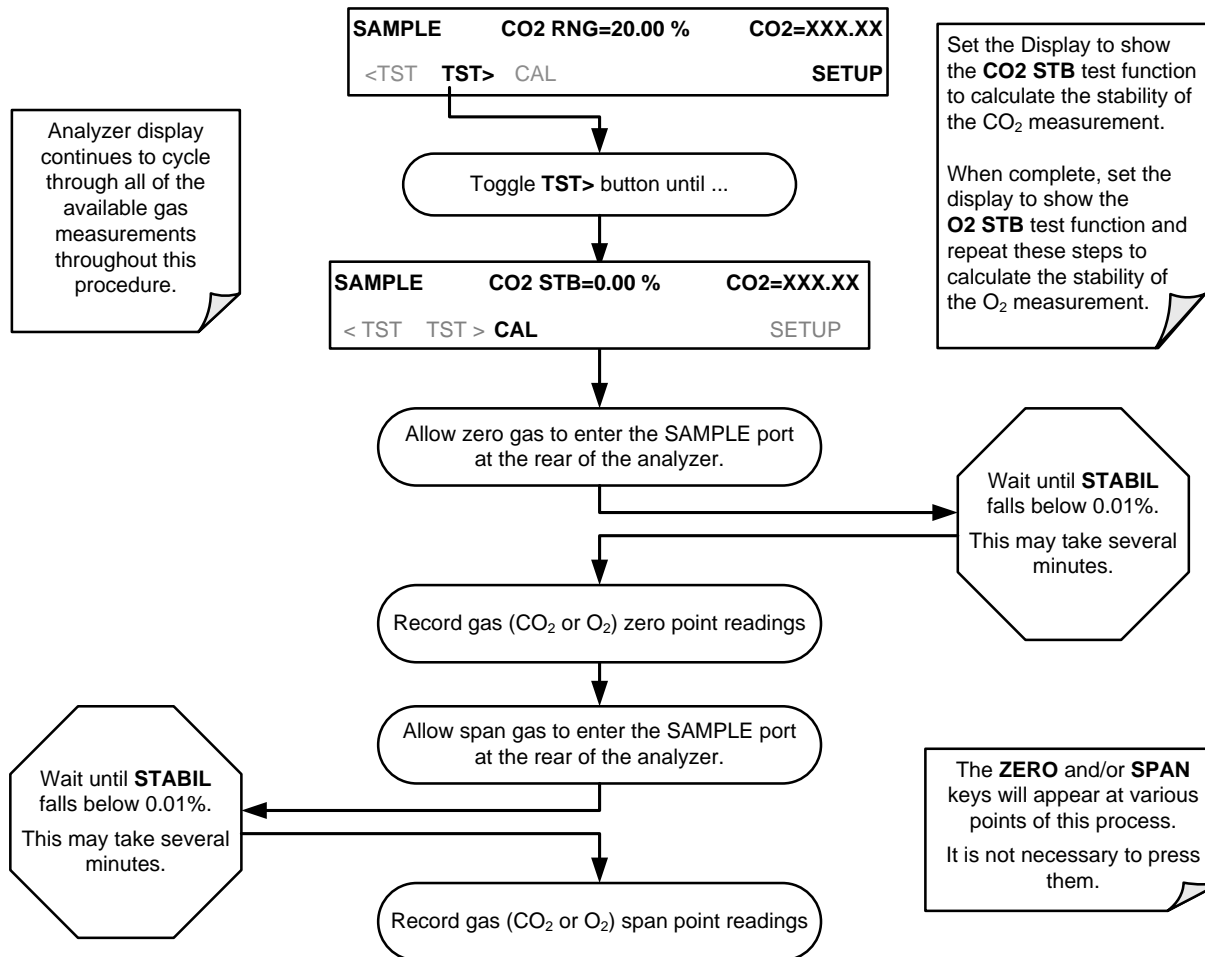

Figure 9-1: Pneumatic Connections Using Bottled Span Gas

9.2.2. PERFORMING A MANUAL CALIBRATION CHECK



Note

If the **ZERO** or **SPAN** menu buttons are not displayed, the measurement made during this cal check is out of the allowable range allowed for a reliable calibration. See Section 11 for troubleshooting tips.

9.2.3. PERFORMING A MANUAL CALIBRATION

The following section describes the basic method for manually calibrating the T803.

If the analyzer's reporting range is set for the **DUAL** or **AUTO** range modes, a step will appear for selecting which range is to be calibrated: **RNG1** (LOW) or **RNG2** (HIGH).

Each of these two ranges **MUST** be calibrated separately.

9.2.3.1. SETTING THE EXPECTED SPAN GAS CONCENTRATION

NOTE
When setting expected concentration values, consider impurities in your span gas.

The expected CO₂ span gas concentration should be 80% of the reporting range of the instrument (see Section 5.4.1)

The default factory setting is 16% for CO₂ or 20.95 % for O₂. To set the span gas concentration, press:

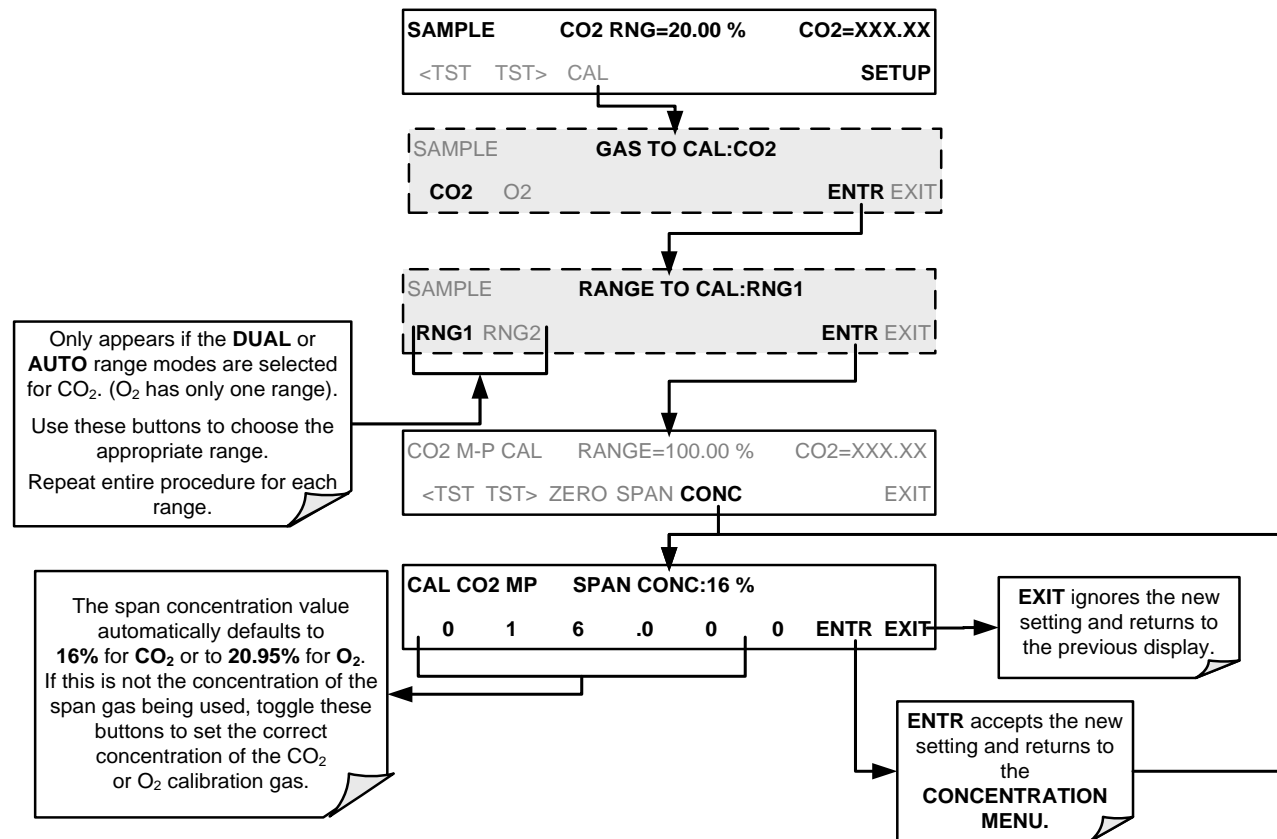

Note

For this Initial Calibration it is important to independently verify the PRECISE Concentration Value of the SPAN gas. If the source of the Span Gas is from a calibrated bottle, use the exact concentration value printed on the bottle.

9.2.3.2. ZERO/SPAN POINT CALIBRATION PROCEDURE

To perform the zero/span calibration procedure:

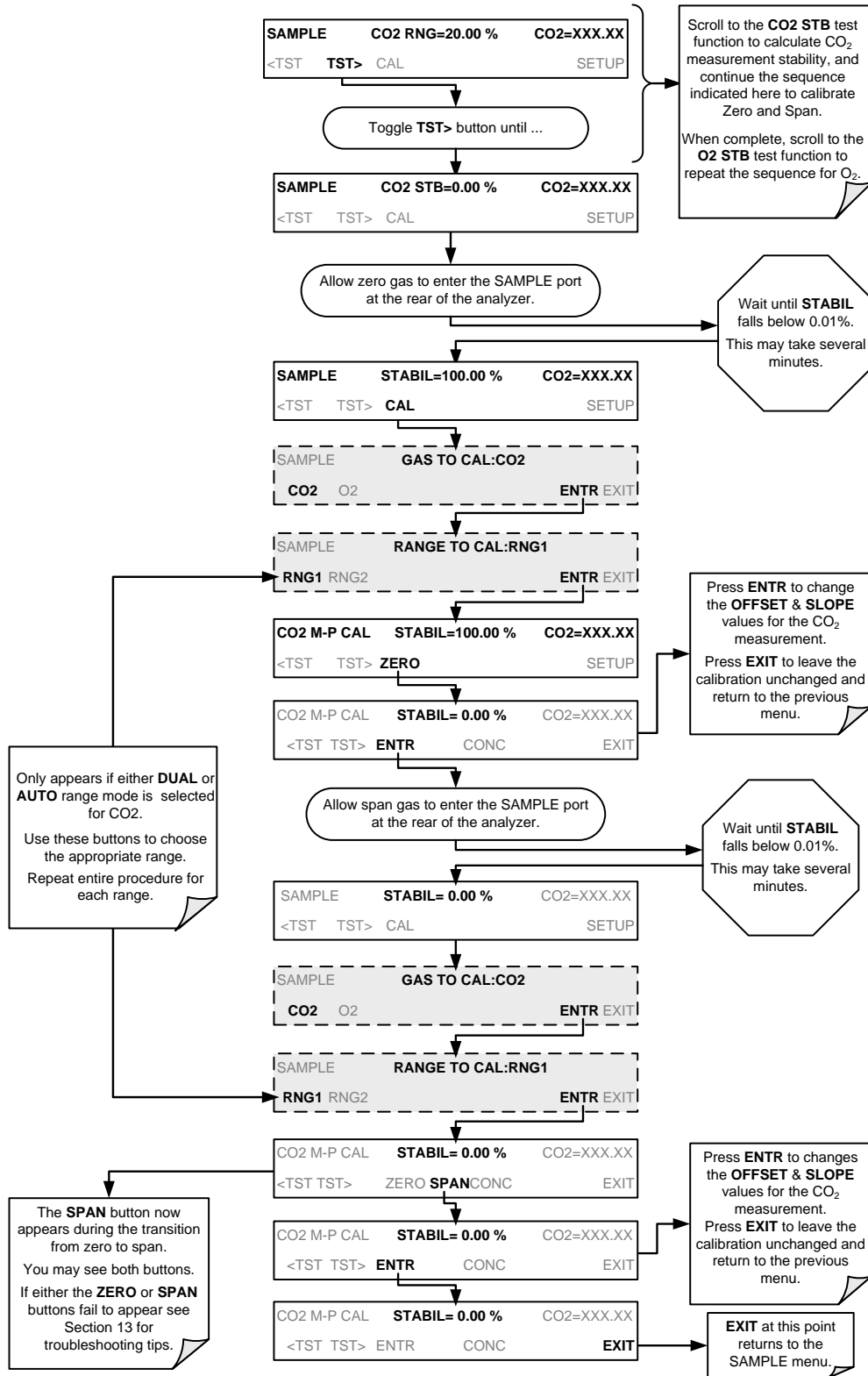

9.3. ASSESSING CALIBRATION QUALITY

After completing one of the calibration procedures described above, it is important to evaluate the analyzer's calibration **SLOPE** and **OFFSET** parameters. These values describe the linear response curve of the analyzer. The values for these terms, both individually and relative to each other, indicate the quality of the calibration.

To perform this quality evaluation, you will need to record the values of both test functions (Section 3.5.1 or Appendix A-3), all of which are automatically stored in the DAS channel CALDAT for data analysis, documentation and archival.

Make sure that these parameters are within the limits listed below and frequently compare them to those values on the *Final Test and Checkout Sheet* (PN 068360000) that came attached to your manual, which should not be significantly different. If they are, refer to troubleshooting in Section 11.

Table 9-2: Calibration Data Quality Evaluation

FUNCTION	MINIMUM VALUE	OPTIMUM VALUE	MAXIMUM VALUE
SLOPE	0.700	1.000	1.300
OFFSET	-0.500	0.000	0.500

These values should not be significantly different from the values recorded on the Teledyne API *Final Test and Validation Data Sheet* that was shipped with your instrument.

If they are, refer to troubleshooting in Section 11.

The default DAS configuration records all calibration values in channel **CALDAT** as well as all calibration check (zero and span) values in its internal memory.

- Up to 200 data points are stored for up 4 years of data (on weekly calibration checks) and a lifetime history of monthly calibrations.
- Review these data to see if the zero and span responses change over time.
- These channels also store the **STABIL** values (standard deviation of the CO₂ and the O₂ concentrations) to evaluate if the analyzer response has properly leveled off during the calibration procedure.

9.4. CALIBRATION OF THE T803'S ELECTRONIC SUBSYSTEMS

9.4.1. PRESSURE CALIBRATION

A sensor in the sample path continuously measures the pressure of the sample gas. This data is used to compensate the measured CO₂ and O₂ concentrations for changes in atmospheric pressure and is stored in the CPU's memory as the test function PRES (also viewable via the front panel).

To carry out this adjustment, the current ambient atmospheric pressure must be known.

Before performing the following pressure calibration, ensure that the pressure being measured by the analyzer's internal sensor is equal to ambient atmospheric pressure by disconnecting:

- The sample gas pump and;
- The sample gas-line vent from the sample gas inlet on the instrument's rear panel.

To cause the analyzer to measure and record a value for PRES, press.

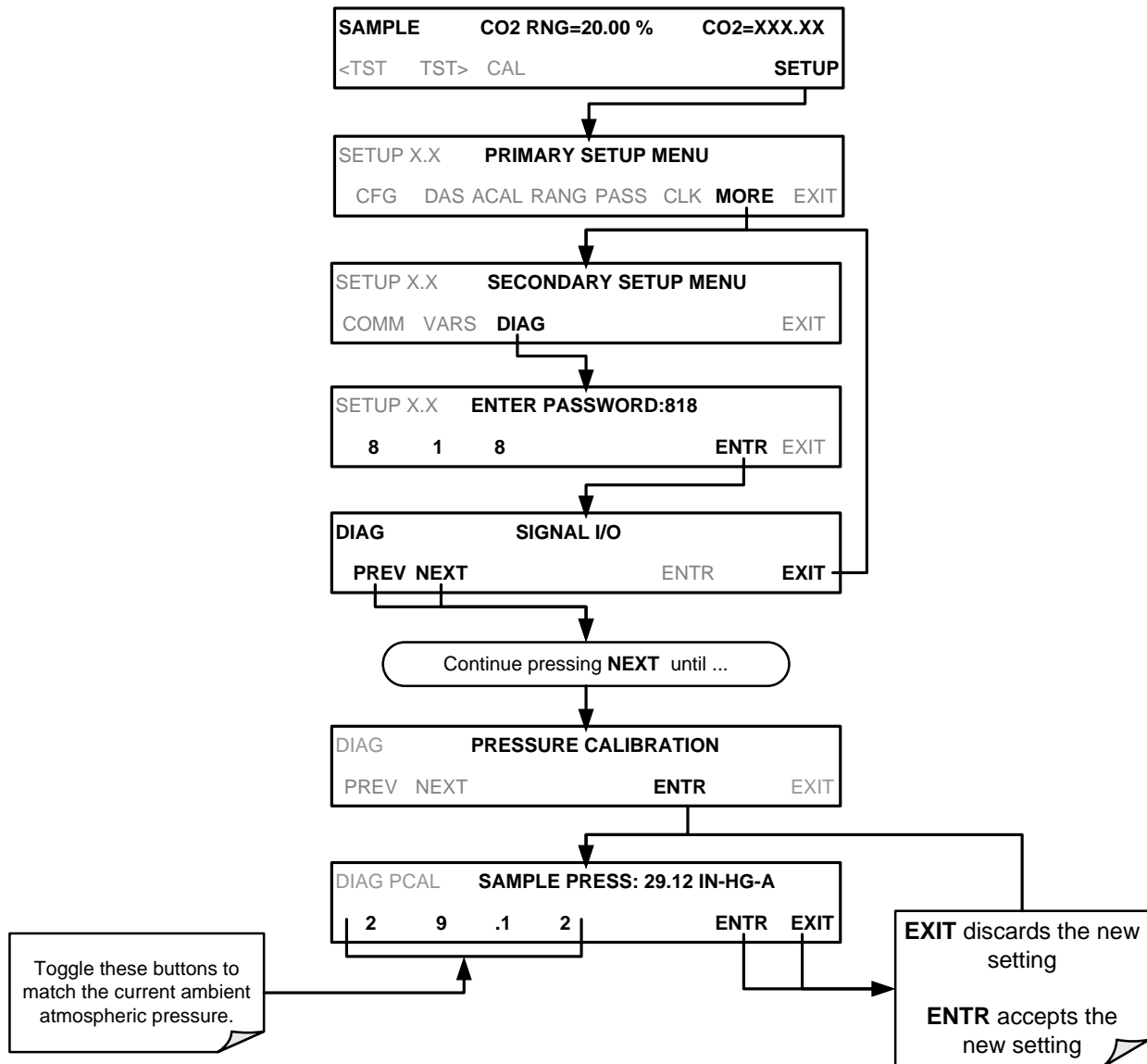

(The ACAL submenu in the Primary Setup Menu is a special configuration; consult factory).

9.4.2. FLOW CALIBRATION

The flow calibration allows the user to adjust the values of the sample flow rates as they are displayed on the front panel and reported through COM ports to match the actual flow rate measured at the SAMPLE inlet. This does not change the hardware measurement of the flow sensors, only the software-calculated values.

To carry out this adjustment, connect an external, sufficiently accurate flow meter to the sample inlet. Once the flow meter is attached and is measuring actual gas flow, press:

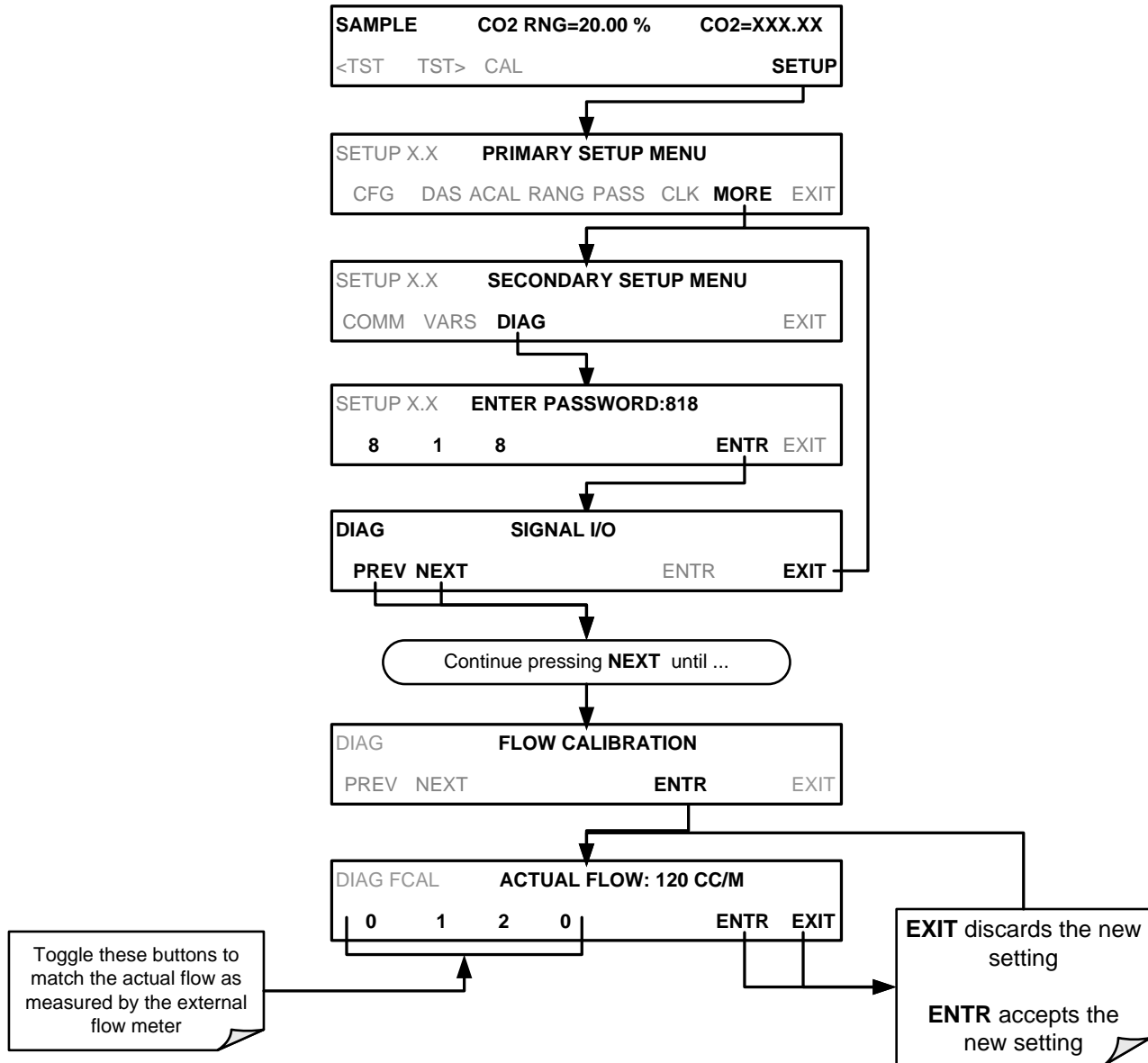

(The ACAL submenu in the Primary Setup Menu is a special configuration; consult factory).

This page intentionally left blank

10. MAINTENANCE SCHEDULE & PROCEDURES

The T803 Analyzer utilizes technologies that are non-depleting and require very little maintenance. However, there are a minimal number of simple procedures that when performed regularly will ensure that the analyzer continues to operate accurately and reliably over its lifetime. Repairs and troubleshooting are covered in Section 11 of this manual.

10.1. MAINTENANCE SCHEDULE

Table 10-1 shows a typical maintenance schedule for the analyzer. Please note that in certain environments (i.e. dusty, very high ambient pollutant levels) some maintenance procedures may need to be performed more often than shown.

Note

A Span and Zero Calibration Check (see CAL CHECK REQ'D Column of Table 10-1) must be performed following certain of the maintenance procedure listed below.



HAZARD – OXYGEN IS A STRONG OXIDIZER.

Before working with the casing open, be sure to turn off power supply, and perform air or N₂ gas purging of not only the analyzer inside, but also the sample gas line.

In addition, carefully prevent oil and grease from adhering to any piping. Otherwise, poisoning, fire or explosion may be caused due to gas leakage, etc.



**CAUTION
GENERAL SAFETY HAZARD**

Risk of electrical shock. Disconnect power before performing any of the following operations that require entry into the interior of the analyzer.



**CAUTION
QUALIFIED PERSONNEL**

The operations outlined in this Section are to be performed by qualified maintenance personnel only.

This page intentionally left blank.

Table 10-1: T803 Maintenance Schedule

ITEM	ACTION	FREQ	CAL CHECK REQ'D.	MANUAL	DATE PERFORMED									
Particulate Filter	Replace	Weekly or as needed	No	10.3.1										
Verify Test Functions	Record and analyze	Weekly or after any Maintenance or Repair	No	11.1.2										
Pump Diaphragm	Replace	Annually	Yes	10.3.2										
Perform Flow Check	Check Flow	Annually	No	10.3.4										
Perform Leak Check	Verify Leak Tight	Annually or after any Maintenance or Repair	No	10.3.3										
Pneumatic lines	Examine and clean	As needed	Yes if cleaned	n/a										
Chassis	Wipe down	As needed	Only if cover removed	n/a										

Table 10-2: T803 Test Function Record

FUNCTION	OPERATING MODE*	DATE RECORDED											
STABIL	O2 ZERO CAL												
STABIL	CO2 ZERO CAL												
PRES	SAMPLE												
CO2 SLOPE	SPAN CAL												
CO2 OFFSET	ZERO CAL												
O2 SLOPE	SPAN CAL												
O2 OFFSET	ZERO CAL												

10.2. PREDICTIVE DIAGNOSTICS

The Test Functions can be used to predict failures by looking at how their values change over time. Initially it may be useful to compare the state of these Test Functions to the values recorded on the printed record of the final calibration performed on your instrument at the factory. Table 10-3 can be used as a basis for taking action as these values change with time. The internal data acquisition system (DAS) is a convenient way to record and track these changes. Use APICOM to download and review this data from a remote location.

Table 10-3: Predictive uses for Test Functions

FUNCTION	CONDITION	BEHAVIOR	INTERPRETATION
STABIL	CO ₂ Zero Cal O ₂ Zero Cal	Increasing	<ul style="list-style-type: none"> • Pneumatic Leaks – instrument & sample system
PRES	Sample	Increasing > 1"	<ul style="list-style-type: none"> • Pneumatic Leak between sample inlet and Sample Cell • Change in sampling manifold
		Decreasing > 1"	<ul style="list-style-type: none"> • Dirty particulate filter • Pneumatic obstruction between sample inlet and sensor • Obstruction in sampling manifold
OFFSET	Zero Cal	Increasing	<ul style="list-style-type: none"> • Pneumatic Leaks • Contaminated zero gas
		Decreasing	<ul style="list-style-type: none"> • Contaminated zero gas
SLOPE	Span Cal	Increasing	<ul style="list-style-type: none"> • Pneumatic Leaks – instrument & sample system • Calibration system deteriorating
		Decreasing	<ul style="list-style-type: none"> • Calibration system deteriorating

10.3. MAINTENANCE PROCEDURES

The following procedures are to be performed periodically as part of the standard maintenance of the T803.

10.3.1. REPLACING THE SAMPLE PARTICULATE FILTER

The particulate filter should be inspected often for signs of plugging or contamination. We recommend that when you change the filter; handle it and the wetted surfaces of the filter housing as little as possible. Do not touch any part of the housing, filter element, PTFE retaining ring, glass cover and the o-ring.

To change the filter:

1. Turn OFF the analyzer to prevent drawing debris into the instrument.
2. Open the T803's hinged front panel and unscrew the knurled retaining ring on the filter assembly.

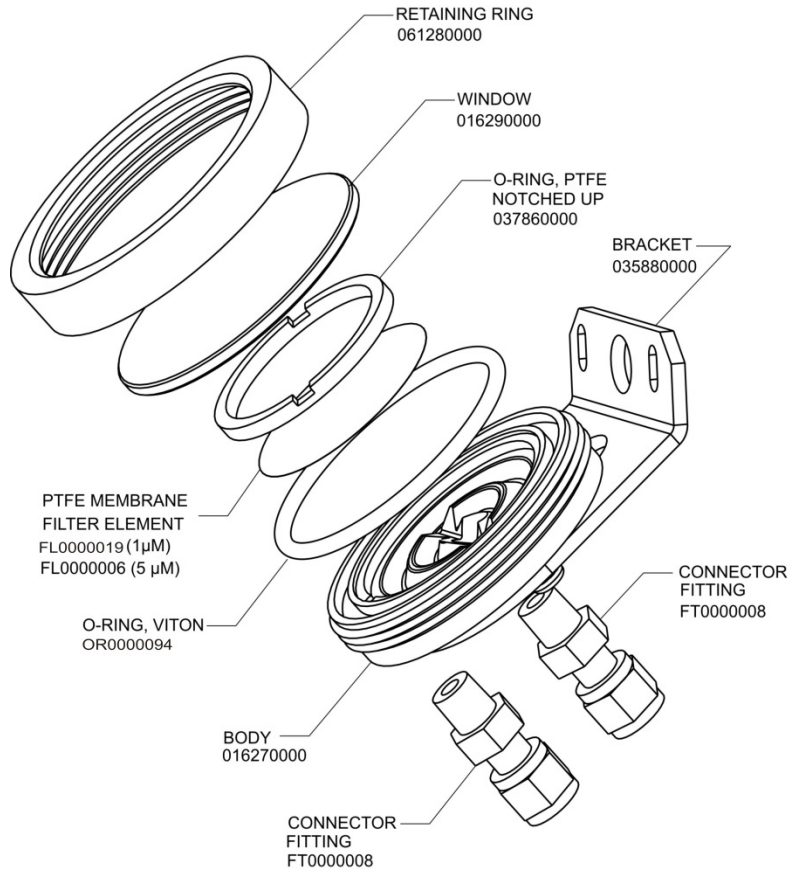

Figure 10-1: Sample Particulate Filter Assembly

3. Carefully remove the retaining ring, PTFE o-ring, glass filter cover and filter element.
4. Replace the filter, being careful that the element is fully seated and centered in the bottom of the holder.
5. Re-install the PTFE o-ring (with the notches up), the glass cover, then screw on the retaining ring and hand tighten. Inspect the seal between the edge of filter and the o-ring to assure a proper seal.
6. Re-start the analyzer.

10.3.2. REBUILDING THE SAMPLE PUMP

The diaphragm in the sample pump periodically wears out and must be replaced. A sample rebuild kit is available – see Appendix B of this manual for the part number of the pump rebuild kit. Instructions and diagrams are included with the kit.

Always perform a Flow and Leak Check after rebuilding the Sample Pump.

10.3.3. PERFORMING LEAK CHECKS



HAZARD
STRONG OXIDIZER

OXYGEN IS A STRONG OXIDIZER.

ONLY Perform Leak Checks using N₂ gas and after thoroughly purging the analyzer's internal pneumatics.

Leaks are the most common cause of analyzer malfunction; Section 10.3.3.1 presents a simple leak check procedure. Section 10.3.3.2 details a more thorough procedure.

10.3.3.1. VACUUM LEAK CHECK AND PUMP CHECK

This method is easy and fast. It detects, but does not locate most leaks. It also verifies that the sample pump is in good condition.

1. Turn the analyzer ON, and allow enough time for flows to stabilize.
2. Cap the SAMPLE inlet port.
3. After several minutes, when the pressures have stabilized, note the following. In the **TEST** menu, note the SAMPLE PRESSURE reading.
4. If the reading is < 10 in-Hg, the pump is in good condition and there are no large leaks.
5. Check the sample gas flow. If the flow is <10 cm³/min and stable, there are no large leaks in the instrument's pneumatics.

10.3.3.2. PRESSURE LEAK CHECK

If you can't locate the leak by the above procedure, use the following procedure. Obtain a leak checker similar to the Teledyne API PN 01960, which contains a small pump, shut-off valve and pressure gauge. Alternatively, a convenient source of low-pressure gas is a tank of span gas, with the two-stage regulator adjusted to less than 15 psi with a shutoff valve and pressure gauge.



CAUTION
GENERAL SAFETY HAZARD

Do not use bubble solution with vacuum applied to the analyzer. The solution may contaminate the instrument. Do not exceed 15 PSI pressure.

1. Turn OFF power to the instrument.
2. Install a leak checker or tank of gas as described above on the SAMPLE inlet at the rear panel.
3. Remove the instrument cover and locate the inlet side of the sample pump. Remove the flow assembly from the pump and plug it with the appropriate gas-tight fitting.
4. Pressurize the instrument with the leak checker, allowing enough time to fully pressurize the instrument through the critical flow orifice. Do not exceed 15 psi pressure. Check each fitting with soap bubble solution, looking for bubbles. Once the fittings have been wetted with soap solution, do not re-apply vacuum, as it will suck soap solution into the instrument and contaminate it. Wipe down and thoroughly dry all parts first.
5. Once the leak has been located and repaired, the leak-down rate should be < 1 in-Hg (0.4 psi) in 5 minutes after the pressure is shut off.

10.3.4. PERFORMING A SAMPLE FLOW CHECK



CAUTION
GENERAL SAFETY HAZARD

Always use a separate calibrated flow meter capable of measuring flows in the 0 – 1000 cm³/min range to measure the gas flow rate through the analyzer.

DO NOT use the built in flow measurement viewable from the Front Panel of the instrument. This measurement is only for detecting major flow interruptions such as clogged or plugged gas lines.

1. Attach the Flow Meter to the SAMPLE inlet port on the rear panel (Figure 3-4). Ensure that the inlet to the Flow Meter is at atmospheric pressure.
2. Sample flow should be 120 cm³/min ± 10%.
3. Once an accurate measurement has been recorded by the method described above, adjust the analyzer's internal flow sensors (See Section 9.4.2).

Low flows indicate blockage somewhere in the pneumatic pathway, typically a plugged sintered filter or critical flow orifice in one of the analyzer's flow control assemblies. High flows indicate leaks downstream of the Flow Control Assembly.

10.3.5. CLEANING EXTERIOR SURFACES OF THE T803

If necessary, the exterior surfaces of the T803 can be cleaned with a clean damp cloth. Do NOT submerge any part of the instrument and do NOT use any cleaning solution.

11. TROUBLESHOOTING AND SERVICE

This section describes a variety of methods for identifying the source of performance problems with the analyzer. Also included here are procedures that are used to repair the instrument.

	HAZARD STRONG OXIDIZER OXYGEN IS A STRONG OXIDIZER.
	<p>Before working with the casing open, be sure to turn off power supply, and perform air or N₂ gas purging of not only the analyzer inside, but also the sample gas line.</p> <p>In addition, carefully prevent oil and grease from adhering to any piping. Otherwise, poisoning, fire or explosion may be caused due to gas leakage, etc.</p>

	NOTE QUALIFIED PERSONNEL
	<p>The operations outlined in this Section must be performed by qualified maintenance personnel only.</p>

	CAUTION RISK OF ELECTRICAL SHOCK
	<ul style="list-style-type: none">•Some operations need to be carried out with the instrument open and running.•Exercise caution to avoid electrical shocks and electrostatic or mechanical damage to the analyzer.•Do not drop tools into the analyzer or leave them after your procedures.•Do not shorten or touch electric connections with metallic tools while operating inside the analyzer.•Use common sense when operating inside a running analyzer.

11.1. GENERAL TROUBLESHOOTING

The T803 CO₂/O₂ analyzer has been designed so that problems can be rapidly detected, evaluated and repaired. During operation, it continuously performs diagnostic tests and provides the ability to evaluate its key operating parameters without disturbing monitoring operations.

A systematic approach to troubleshooting will generally consist of the following five steps:

1. Note any **WARNING MESSAGES** and take corrective action as necessary.
2. Examine the values of all TEST functions and compare them to factory values. Note any major deviations from the factory values and take corrective action.
3. Use the internal electronic status LEDs to determine whether the electronic communication channels are operating properly.

Verify that the DC power supplies are operating properly by checking the voltage test points on the relay PCA.

Note that the analyzer's DC power wiring is color-coded and these colors match the color of the corresponding test points on the relay PCA.

4. **SUSPECT A LEAK FIRST!**

Technical Support data indicate that the majority of all problems are eventually traced to leaks in the internal pneumatics of the analyzer or the diluent gas and source gases delivery systems.

Check for gas flow problems such as clogged or blocked internal/external gas lines, damaged seals, punctured gas lines, a damaged / malfunctioning pumps, etc.

5. Follow the procedures defined in Section 11.6 to confirm that the analyzer's vital functions are working (power supplies, CPU, relay PCA, etc.).

See Figure 3-5 for the general layout of components and sub-assemblies in the analyzer.

See the wiring interconnect diagram and interconnect list in Appendix D.

11.1.1. FAULT DIAGNOSIS WITH WARNING MESSAGES

The most common and/or serious instrument failures will result in a warning message being displayed on the front panel. Table 11-1 lists warning messages, along with their meaning and recommended corrective action.

It should be noted that if more than two or three warning messages occur at the same time, it is often an indication that some fundamental analyzer sub-system (power supply, relay board, motherboard) has failed rather than indication of the of the specific failures referenced by the warnings. In this case, it is recommended that proper operation of power supplies (See Section 11.6.2), the relay board (See Section 11.6.6), and the A/D Board (See Section 11.6.9.1) be confirmed before addressing the specific warning messages.

The analyzer will alert the user that a Warning Message is active by flashing the FAULT LED, displaying the Warning message in the Param field along with the CLR button (press to clear Warning message). The MSG button displays if there is more than one warning in queue or if you are in the TEST menu and have not yet cleared the message. The following display/touchscreen examples provide an illustration of each:



Top: the CLR button is available to clear the warning message displayed in the Param field.

Bottom: the MSG button indicates that at least one warning message has not yet been cleared.

The analyzer will also alert the user via the Serial I/O COM port(s).

To view or clear the various warning messages press:

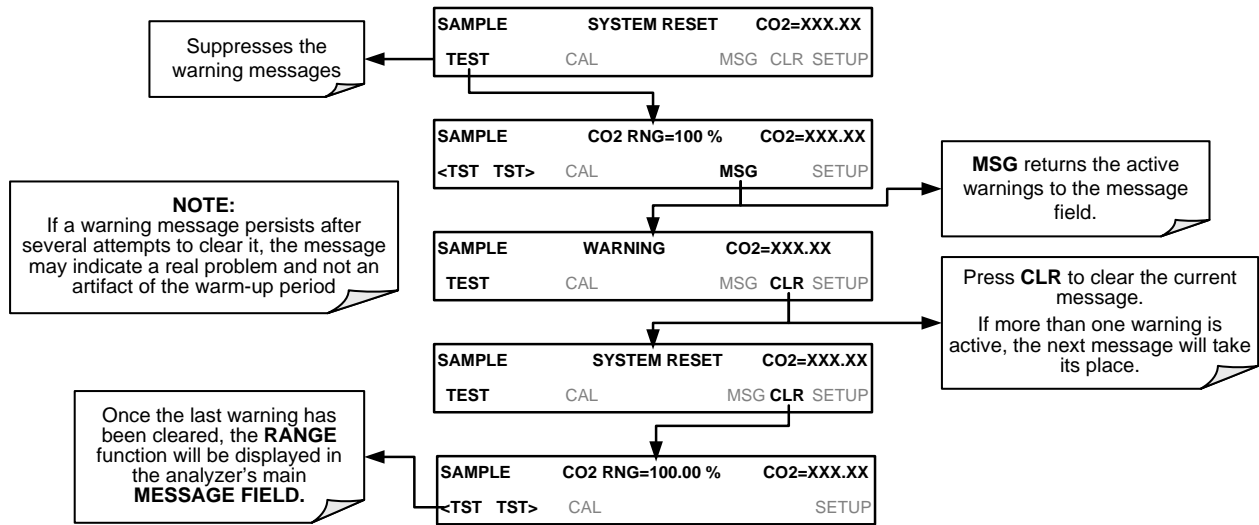

Figure 11-1: Viewing and Clearing Warning Messages

Table 11-1: Warning Messages - Indicated Failures

WARNING MESSAGE	FAULT CONDITION	POSSIBLE CAUSES
O ₂ CELL TEMP WARN	Sensor cell temperature is outside specified warning limits	Bad bench heater Bad bench temperature sensor Bad relay controlling the bench heater Entire relay board is malfunctioning I ² C bus malfunction
CO ₂ CELL TEMP WARN	Sensor cell temperature is outside specified warning limits	Bad bench heater Bad bench temperature sensor Bad relay controlling the bench heater Entire relay board is malfunctioning I ² C bus malfunction
BOX TEMP WARNING	Box Temp is < 8 °C or > 50 °C.	NOTE: Box temperature typically runs ~7°C warmer than ambient temperature. Poor/blocked ventilation to the analyzer. Stopped exhaust-fan Ambient temperature outside of specified range
CANNOT DYN SPAN	Dynamic Span operation failed	Measured concentration value is too high or low. Concentration slope value to high or too low
CANNOT DYN ZERO	Dynamic Zero operation failed	Measured concentration value is too high. Concentration offset value to high.
CONFIG INITIALIZED	Configuration and Calibration data reset to original Factory state.	Failed disk on module User erased data
DATA INITIALIZED	Data Storage in DAS was erased	Failed Disk on Module User cleared data
REAR BOARD NOT DET	Motherboard not detected on power up.	Warning only appears on serial I/O COM port(s) Front panel display will be frozen, blank or will not respond. Massive failure of motherboard

WARNING MESSAGE	FAULT CONDITION	POSSIBLE CAUSES
RELAY BOARD WARN	The CPU cannot communicate with the Relay Board.	I ² C bus failure Failed relay board Loose connectors/wiring
SAMPLE FLOW WARN	Sample flow rate is < 80 cm ³ /min or > 180 cm ³ /min	Failed sample pump Blocked sample inlet/gas line Dirty particulate filter Leak downstream of critical flow orifice Failed flow sensor/circuitry
SAMPLE PRES WARN	Sample Pressure is <15 in-Hg or > 35 in-Hg Normally 29.92 in-Hg at sea level decreasing at 1 in-Hg per 1000 ft of altitude (with no flow – pump disconnected).	If sample pressure is < 15in-Hg: Blocked particulate filter Blocked sample inlet/gas line Failed pressure sensor/circuitry If sample pressure is > 35 in-Hg: Pressurized sample gas. Install vent Blocked vent line on pressurized sample/zero/span gas supply Bad pressure sensor/circuitry
SYSTEM RESET	The computer has rebooted.	This message occurs at power on. If you have not cycled the power on your instrument: Failed +5 VDC power, Fatal error caused software to restart Loose connector/wiring

11.1.2. FAULT DIAGNOSIS WITH TEST FUNCTIONS

In addition to being useful as predictive diagnostic tools, the test functions viewable from the front panel can be used to isolate and identify many operational problems when combined with a thorough understanding of the analyzer's theory of operation (Section 12).

The acceptable ranges for these test functions are listed in the "Nominal Range" column of the analyzer Final Test and Validation Data Sheet (PN 068360000) shipped with the instrument. Values outside these acceptable ranges indicate a failure of one or more of the analyzer's subsystems. Functions whose values are still within the acceptable range but have significantly changed from the measurement recorded on the factory data sheet may also indicate a failure.

Note

A worksheet has been provided in Appendix C to assist in recording the value of these test functions. This worksheet also includes expected values for the various test functions.

The following table contains some of the more common causes for these values to be out of range.

Table 11-2: Test Functions - Indicated Failures

TEST FUNCTIONS (As Displayed)	INDICATED FAILURE(S)
TIME	Time of day clock is too fast or slow To adjust See Section 5.6. Battery in clock chip on CPU board may be dead.
RANGE	Incorrectly configured measurement range(s) could cause response problems with a Data logger or chart recorder attached to one of the analog output. If the Range selected is too small, the recording device will over range. If the Range is too big, the device will show minimal or no apparent change in readings.
STABIL	Indicates noise level of instrument or concentration of sample gas (See Section 11.3 for causes).
PRES	See Table 11-1 for SAMPLE PRES WARN
SAMPLE FL	Check for gas flow problems (see Section 11.3).
O2 CELL TEMP	Temperatures outside of the specified range or oscillating temperatures are cause for concern
BOX TEMP	If the box temperature is out of range, check fan in the power supply module. Areas to the side and rear of instrument should allow adequate ventilation. See Table 11-1 for BOX TEMP WARNING .
O2 SLOPE	Values outside range indicate Contamination of the zero air or span gas supply Instrument is miscalibrated Blocked gas flow Bad/incorrect span gas concentration due.
O2 OFFSET	Values outside range indicate contamination of the zero air supply

11.1.3. DIAG → SIGNAL I/O: USING THE DIAGNOSTIC SIGNAL I/O FUNCTION

The signal I/O diagnostic mode allows access to the digital and analog I/O in the analyzer. Some of the digital signals can be controlled through the touchscreen. These signals, combined with a thorough understanding of the instruments Theory of Operation (found in Section 12), are useful for troubleshooting in three ways:

- The technician can view the raw, unprocessed signal level of the analyzer’s critical inputs and outputs.
- Many of the components and functions that are normally under algorithmic control of the CPU can be manually exercised.
- The technician can directly control the signal level Analog and Digital Output signals.

This allows the technician to observe systematically the effect of directly controlling these signals on the operation of the analyzer. The following flowchart shows an example of how to use the Signal I/O menu to view the raw voltage of an input signal or to control the state of an output voltage or control signal.

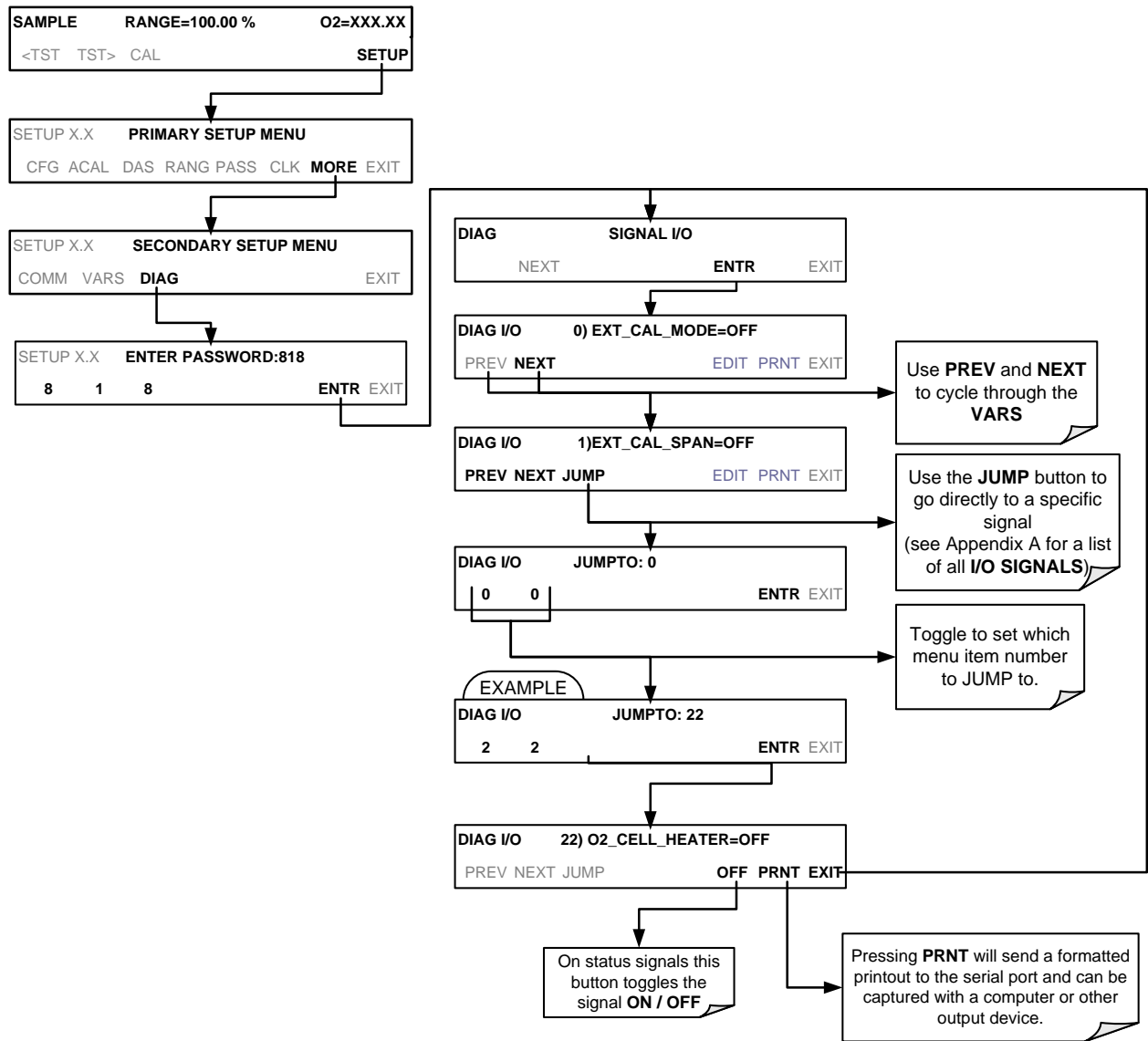

Figure 11-2: Example of Signal I/O Function

(The ACAL submenu in the Primary Setup Menu is a special configuration; consult factory).

Note

Any I/O signals changed while in the signal I/O menu will remain in effect ONLY until signal I/O menu is exited. The Analyzer regains control of these signals upon exit.

11.2. USING THE INTERNAL ELECTRONIC STATUS LEDES

Several LEDs are located inside the instrument to assist in determining if the analyzer’s CPU, I²C bus and relay board are functioning properly.

11.2.1. CPU STATUS INDICATOR

DS5, a red LED, that is located on upper portion of the motherboard, just to the right of the CPU board, flashes when the CPU is running the main program loop. After power-up, approximately 30 to 60 seconds, DS5 should flash on and off. If characters are written to the front panel display but DS5 does not flash, then the program files have become corrupted. If after 30 – 60 seconds neither the DS5 is flashing or no characters have been written to the front panel display, then the CPU is bad and must be replaced.

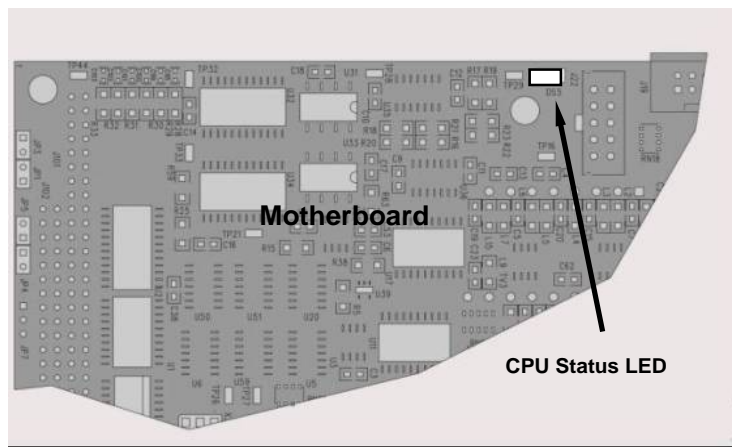

Figure 11-3: CPU Status Indicator

11.2.2. RELAY PCA STATUS INDICATORS

There are sixteen status indicator LEDs located on the Relay PCA. Some are not used on this model.

11.2.2.1. I²C BUS WATCHDOG STATUS LEDES

The most important is D1 (which indicates the health of the I²C bus).

Table 11-3: Relay PCA Watchdog LED Failure Indications

LED	Function	Fault Status	Indicated Failure(s)
D1 (Red)	I ² C bus Health (Watchdog Circuit)	Continuously ON or Continuously OFF	Failed/Halted CPU Faulty Motherboard, Keyboard or Relay PCA Faulty Connectors/Wiring between Motherboard, Keyboard or Relay PCA Failed/Faulty +5 VDC Power Supply (PS1)

If D1 is blinking, then the other LEDs can be used in conjunction with **DIAG** Menu Signal I/O to identify hardware failures of the relays and switches on the Relay PCA.

11.2.2.2. RELAY PCA STATUS LED S

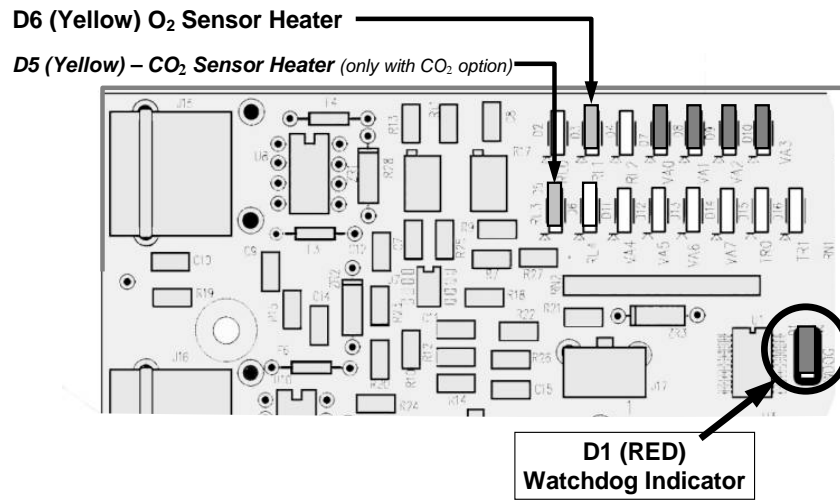

Figure 11-4: Relay PCA Status LEDs Used for Troubleshooting

Table 11-4: Relay PCA Status LED Failure Indications

LED	Color	Function	Status When LED Lit (Energized State)	Status When LED Unlit (Default State)
D1	Red	Watchdog Circuit	Cycles ON/OFF every 3 Seconds under direct control of the analyzer's CPU.	
D2-D4	SPARE			
D5	Yellow	CO ₂ Sensor Cell heater	Heating	Not Heating
D6	Yellow	O ₂ Sensor heater	Heating	Not Heating
D7 ²	Green			
D8 ²	Green			
D9 ²	Green			
D10 ²	Green			
D11 - 16	SPARE			

² Not Used

11.3. GAS FLOW PROBLEMS

When troubleshooting flow problems, it is a good idea to first confirm that the actual flow and not the analyzer’s flow sensor and software are in error, or the flow meter is in error. Use an independent flow meter to perform a flow check as described in Section 10.3.4. If this test shows the flow to be correct, check the pressure sensors as described in Section 11.6.8.

In general, flow problems can be divided into three categories:

- Flow is too high
- Flow is greater than zero, but is too low, and/or unstable
- Flow is zero (no flow)

When troubleshooting flow problems, it is crucial to confirm the actual flow rate without relying on the analyzer’s flow display. The use of an independent, external flow meter to perform a flow check as described in Section 10.3.4 is essential.

The flow diagrams found in a variety of locations within this manual depicting the T803 in its standard configuration and with options installed, can help in trouble-shooting flow problems. For your convenience the diagrams are collected here.

11.3.1. T803 INTERNAL GAS FLOW DIAGRAMS

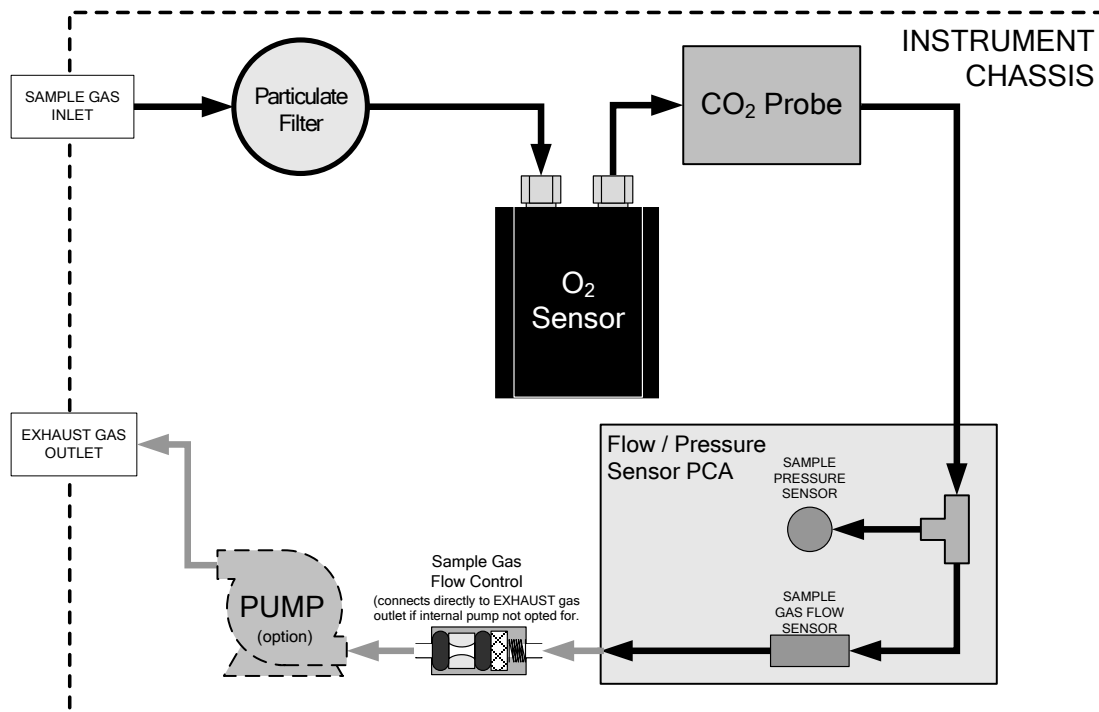

Figure 11-5: T803 – Internal Gas Flow

11.3.2. TYPICAL SAMPLE GAS FLOW PROBLEMS

11.3.2.1. FLOW IS ZERO

The unit displays a **SAMPLE FLOW** warning message on the front panel display or the **SAMPLE FLOW** test function reports a zero or very low flow rate.

Confirm that the sample pump is operating (turning). If not, use an AC voltmeter to make sure that power is being supplied to the pump. If no power is present at the electrical leads of the pump, take the following steps:

1. If AC power is being supplied to the pump, but it is not turning, replace the pump.
2. If the pump is operating but the unit reports no gas flow, perform a flow check as described in Section 10.3.4.
3. If no independent flow meter is available:
 - Disconnect the gas lines from both the sample inlet and the exhaust outlet on the rear panel of the instrument.
 - Make sure that the unit is in basic **SAMPLE Mode**.
 - Place a finger over a Sample inlet on the rear panel of the instrument.
 - If gas is flowing through the analyzer, you will feel a vacuum suction at the inlet.
4. If gas flows through the instrument when it is disconnected from its sources of zero air, span gas or sample gas, the flow problem is most likely not internal to the analyzer. Check to ensure that:
 - All calibrators/generators are turned on and working correctly.
 - Gas bottles are not empty or low.
 - Valves, regulators and gas lines are not clogged or dirty.

11.3.2.2. LOW FLOW

1. Check if the pump diaphragm is in good condition. If not, rebuild the pump (See Section 10.3.2). Check the Spare Parts List for information on pump rebuilding kits.
2. Check for leaks as described in Section 10.3.3. Repair the leaking fitting, line and re-check.
3. Check for the sample filter and the orifice filter for dirt. Replace filters (See 10.3.1).
4. Check for partially plugged pneumatic lines. Clean or replace them.
5. Check for plugged or dirty critical flow orifices. Replace them.

11.3.2.3. HIGH FLOW

The most common cause of high flow is a leak in the sample flow control. If no leaks or loose connections are found in the fittings or the gas line between the orifice and the pump, replace the critical flow orifice inside the sample flow control assembly.

11.3.2.4. DISPLAYED FLOW WARNINGS

This warning means that there is inadequate gas flow. There are four conditions that might cause this:

- A leak upstream or downstream of the flow sensor
- A flow obstruction upstream or downstream of the flow sensor
- Bad Flow Sensor Board
- Bad pump

To determine which condition is causing the flow problem, view the sample pressure and sample flow functions on the front panel display. If the sample pressure is reading abnormally low, then the cause is likely a flow obstruction upstream of the flow sensor. First, check the sample filter and make sure it is not plugged and then systematically check all the other components upstream of the orifice to ensure that they are not obstructed.

If the sample pressure is reading normal but the sample flow is reading low, then it is likely that the pump diaphragm is worn or there is an obstruction downstream of the flow sensor.

11.3.2.5. ACTUAL FLOW DOES NOT MATCH DISPLAYED FLOW

If the actual flow measured does not match the displayed flow, but is within the limits of 110-130 cm³/min, adjust the calibration of the flow measurement as described in Section 10.3.4.

11.3.2.6. SAMPLE PUMP

The sample pump should start immediately after the front panel power switch is turned ON. With the SAMPLE inlet plugged the test function PRES should read less than 10”-Hg for a pump in good condition. Readings above 10” Hg indicate that the pump needs rebuilding. If the test function SAMP FL is greater than 10 cm³/min there is a leak in the pneumatic lines.

11.4. CALIBRATION PROBLEMS

11.4.1. MISCALIBRATED

There are several symptoms that can be caused by the analyzer being miscalibrated. Miscalibration is indicated by out-of-range Slopes and Offsets as displayed through the test functions and is frequently caused by the following:

- Bad span gas: This can cause a large error in the slope and a small error in the offset. Delivered from the factory, the T803's slope is within $\pm 15\%$ of nominal. Bad span gas will cause the analyzer to be calibrated to the wrong value. If in doubt have the span gas checked by an independent lab.
- Contaminated zero gas: Excess H₂O can cause a positive or negative offset and will indirectly affect the slope.
- Dilution calibrator not set up correctly or is malfunctioning: This will also cause the slope, but not the zero, to be incorrect. Again the analyzer is being calibrated to the wrong value.
- Too many analyzers on the manifold: This can cause either a slope or offset error because ambient gas with its pollutants will dilute the zero or span gas.

11.4.2. NON-REPEATABLE ZERO AND SPAN

As stated earlier, leaks both in the T803 and in the external system are a common source of unstable and non-repeatable readings.

1. Check for leaks in the pneumatic systems as described in Section 10.3.3. Don't forget to consider pneumatic components in the gas delivery system outside the T803. Such as:
 - A change in zero air source such as ambient air leaking into zero air line, or;
 - A change in the span gas concentration due to zero air or ambient air leaking into the span gas line.
2. Once the instrument passes a leak check, do a flow check (See Section 10.3.4) to make sure adequate sample is being delivered to the sensor assembly.
3. Confirm the sample pressure, sensor temperatures, and sample flow readings are correct and have steady readings.
4. Disconnect the exhaust line from the optical bench near the rear of the instrument and plug this line into the SAMPLE inlet creating a pneumatic loop. The concentration (either zero or span) now must be constant. If readings become quiet, the problem is in the external pneumatics supplies for sample gas, span gas or zero air.

11.4.3. INABILITY TO SPAN – NO SPAN BUTTON

1. Confirm that the oxygen span gas source is accurate; this can be done by opening the analyzer's SAMPLE inlet to ambient air. If the concentration is not displayed as ~20.9%, there is a problem with the span gas.
2. Check for leaks in the pneumatic systems as described in Section 10.3.3.
3. Make sure that the expected span gas concentration entered into the instrument during calibration, is the correct span gas concentration and not too different from expected span value. This can be viewed via the CONC submenu of the Sample displays.
4. Check to make sure that there is no ambient air or zero air leaking into span gas line.

11.4.4. INABILITY TO ZERO – NO ZERO BUTTON

1. Confirm that there is a good source of zero air. Dilute a tank of span gas with the same amount of zero air from two different sources. If the O₂ concentration of the two measurements is different, there is a problem with one of the sources of zero air.
2. Check for leaks in the pneumatic systems as described in 10.3.3.
3. Check to make sure that there is no ambient air leaking into zero air line.

11.5. OTHER PERFORMANCE PROBLEMS

Dynamic problems (i.e. problems which only manifest themselves when the analyzer is monitoring sample gas) can be the most difficult and time consuming to isolate and resolve. The following provides an itemized list of the most common dynamic problems with recommended troubleshooting checks and corrective actions.

11.5.1. TEMPERATURE PROBLEMS

Individual control loops are used to maintain the set point of the temperatures to both sensors.. If any of these temperatures are out of range or are poorly controlled, the T803 will perform poorly.

BOX TEMPERATURE

The box temperature sensor is mounted to the motherboard and cannot be disconnected to check its resistance. Rather check the **BOX TEMP** signal using the SIGNAL I/O function under the **DIAG** Menu (See Section 5.9). This parameter will vary with ambient temperature, but at ~30°C (6-7° above room temperature) the signal should be ~1450 mV.

11.6. SUBSYSTEM CHECKOUT

Section 10 discussed a variety of methods for identifying possible sources of failures or performance problems within the analyzer. In most cases this included a list of possible causes. This describes how to determine individually determine if a certain component or subsystem is actually the cause of the problem being investigated.

11.6.1. AC MAINS CONFIGURATION

The analyzer is correctly configured for the AC mains voltage in use if:

1. The Sample Pump is running.
2. If incorrect power is suspected, check that the correct voltage and frequency is present at the line input on the rear panel.
 - If the unit is set for 230 VAC and is plugged into 115VAC, or 100VAC the sample pump will not start, and the heaters will not come up to temperature.
 - If the unit is set for 115 or 100 VAC and is plugged into a 230 VAC circuit, the circuit breaker built into the ON/OFF Switch on the Front Panel will trip to the OFF position immediately after power is switched on.

11.6.2. DC POWER SUPPLY

If you have determined that the analyzer's AC mains power is working, but the unit is still not operating properly, there may be a problem with one of the instrument's switching power supplies. The supplies can have two faults, namely no DC output, and noisy output.

To assist tracing DC Power Supply problems, the wiring used to connect the various printed circuit assemblies and DC Powered components and the associated test points on the relay board follow a standard color-coding scheme as defined in the following table.

Table 11-5: DC Power Test Point and Wiring Color Codes

NAME	TEST POINT#	TP AND WIRE COLOR
Dgnd	1	Black
+5V	2	Red
Agnd	3	Green
+15V	4	Blue
-15V	5	Yellow
+12V Ret (ground)	6	Purple
+12V	7	Orange

A voltmeter should be used to verify that the DC voltages are correct per the values in the table below, and an oscilloscope, in AC mode, with band limiting turned on, can be used to evaluate if the supplies are producing excessive noise (> 100 mV p-p).

Table 11-6: DC Power Supply Acceptable Levels

POWER SUPPLY ASSY	VOLTAGE	CHECK RELAY BOARD TEST POINTS				MIN V	MAX V
		FROM TEST POINT		TO TEST POINT			
		NAME	#	NAME	#		
PS1	+5	Dgnd	1	+5	2	4.85	5.25
PS1	+15	Agnd	3	+15	4	13.5	16V
PS1	-15	Agnd	3	-15V	5	-13.5V	-16V
PS1	Agnd	Agnd	3	Dgnd	1	-0.05	0.05
PS1	Chassis	Dgnd	1	Chassis	N/A	-0.05	0.05
PS2	+12	+12V Ret	6	+12V	7	11.75	12.5
PS2	Dgnd	+12V Ret	6	Dgnd	1	-0.05	0.05

11.6.3. I²C BUS

Operation of the I²C bus can be verified by observing the behavior of D1 on the Relay Board in conjunction with the performance of the front panel display. Assuming that the DC power supplies are operating properly and the wiring is intact, the I²C bus is operating properly if:

- D1 on the relay board is flashing, or;
- D1 is not flashing but pressing a button on the touchscreen results in a change to the display.

11.6.4. TOUCHSCREEN INTERFACE

Verify the functioning of the touchscreen by observing the display when pressing a touchscreen control button. Assuming that there are no wiring problems and that the DC power supplies are operating properly, if pressing a control button on the display does not change the display, any of the following may be the problem:

- The touchscreen controller may be malfunctioning.
- The internal USB bus may be malfunctioning.

You can verify this failure by logging on to the instrument using APICOM or a terminal program to any of the communications ports. If the analyzer responds to remote commands and the display changes accordingly, the touchscreen interface may be faulty.

11.6.5. LCD DISPLAY MODULE

Verify the functioning of the front panel display by observing it when power is applied to the instrument. Assuming that there are no wiring problems and that the DC power supplies are operating properly, the display screen should light and show the splash screen with logo and other indications of its state as the CPU goes through its initialization process.

11.6.6. RELAY BOARD

The relay board PCA (04135) can be most easily checked by observing the condition of the its status LEDs on the relay board, as described in Section 12.6.3.1, and the associated output when toggled on and off through signal I/O function in the diagnostic menu, See Section 11.1.3.

1. If the front panel display responds to key presses and D1 on the relay board is NOT flashing then either the wiring between the Keyboard and the relay board is bad, or the relay board is bad.
2. If D1 on the relay board is flashing and the status indicator for the output in question (heater power etc.) toggles properly using the signal I/O function, then the associated control device on the relay board is bad. (Several of the control devices are in sockets and can be easily replaced).

11.6.7. SENSOR ASSEMBLY

Both the CO₂ and O₂ sensors have no user serviceable parts.

11.6.8. PRESSURE/FLOW SENSOR ASSEMBLY

The pressure/flow sensor PCA can be checked with a Voltmeter using the following procedure which, assumes that the wiring is intact, and that the motherboard and the power supplies are operating properly:

1. For Pressure related problems:

- Measure the voltage across C1 it should be 5 ± 0.25 VDC.
 - ⚠ If not then the board is bad.
- Measure the voltage across TP4 and TP1.
 - ⚠ With the sample pump disabled it should be $4500 \text{ mV} \pm 250 \text{ mV}$.
 - ⚠ With the pump energized it should be approximately 200 mV less. If not, then S1, the pressure transducer is bad, the board is bad, or there is a pneumatic failure preventing the pressure transducer from sensing the absorption cell pressure properly.

2. For flow related problems:

- Measure the voltage across TP2 and TP1 it should be 10 ± 0.25 VDC.
 - ⚠ If not then the board is bad.
 - ⚠ With flow stopped (sample inlet blocked) the voltage should be approximately 1V.
 - ⚠ If the voltage is incorrect, the flow sensor is bad, the board is bad or there is a leak upstream of the sensor.

11.6.9. MOTHERBOARD

11.6.9.1. A/D FUNCTIONS

The simplest method to check the operation of the A-to-D converter on the motherboard is to use the Signal I/O function under the **DIAG** menu to check the two A/D reference voltages and input signals that can be easily measured with a voltmeter.

1. Use the Signal I/O function (See Section 11.1.3 and Appendix A) to view the value of REF_4096_MV and REF_GND.
 - If both are within 3 mV of nominal (4096 and 0), and are stable, ± 0.2 mV then the basic A/D is functioning properly. If not then the motherboard is bad.
2. Choose a parameter in the Signal I/O function such as SAMPLE_PRESSURE or SAMPLE_FLOW.
 - Compare these voltages at their origin (see interconnect drawing PN 06407 and interconnect list PN 06294 in Appendix D) with the voltage displayed through the signal I/O function.
 - If the wiring is intact but there is a large difference between the measured and displayed voltage (± 10 mV) then the motherboard is bad.

11.6.9.2. ANALOG OUTPUTS: CURRENT LOOP

To verify that the analog outputs with the optional current mode output are working properly, connect a 250 ohm resistor across the outputs and use a voltmeter to measure the output as described in Section 5.10.3.4.

For each step the output should be within 1% of the nominal value listed in the table below.

Table 11-7: Analog Output Test Function - Nominal Values Current Outputs

		OUTPUT RANGE			
		2 -20		4 -20	
		NOMINAL OUTPUT VALUES			
STEP	%	CURRENT	V(250 OHMS)	CURRENT	V(250 OHMS)
1	0	2 mA	0.5V	4	1
2	20	5.6	1.4	7.2	1.8
3	40	9.2	2.3	10.4	2.6
4	60	12.8	3.2	13.6	3.4
5	80	16.4	4.1	16.8	4.2
6	100	20	5	20	5

11.6.9.3. STATUS OUTPUTS

The procedure below can be used to test the Status outputs:

1. Connect a jumper between the “D” pin and the “▽” pin on the status output connector.
2. Connect a 1000 ohm resistor between the “+” pin and the pin for the status output that is being tested.
3. Connect a voltmeter between the “▽” pin and the pin of the output being tested (see table below).

Under the **DIAG** → SIGNAL I/O menu (See Section 11.1.3), scroll through the inputs and outputs until you get to the output in question. Alternately turn on and off the output noting the voltage on the voltmeter, it should vary between 0 volts for ON and 5 volts for OFF.

Table 11-8: Status Outputs Check

PIN (LEFT TO RIGHT)	STATUS
1	SYSTEM OK / ALARM
2	CONC VALID / CONC WARNING
3	CALIBRATION MODE / MEASURE MODE
4	SPAN / ZERO CAL
5	RNG2 / RNG1 CAL
6	CO ₂ / O ₂ SENSOR CAL
7	SPARE
8	SPARE

11.6.10. CPU

There are two major types of failures associated with the CPU board: complete failure and a failure associated with the Disk-On-Module (DOM) on the CPU board. If either of these failures occurs, contact the factory.

For complete failures, assuming that the power supplies are operating properly and the wiring is intact, the CPU is faulty if on power-on, the watchdog LED on the motherboard is not flashing.

In some rare circumstances, this failure may be caused by a bad IC on the motherboard, specifically U57, the large, 44 pin device on the lower right hand side of the board. If this is true, removing U57 from its socket will allow the instrument to start up but the measurements will be invalid.

If the analyzer stops during initialization (the front panel display shows a fault or warning message), it is likely that the DOM, the firmware or the configuration and data files have been corrupted.

11.6.11. RS-232 COMMUNICATIONS

11.6.11.1. GENERAL RS-232 TROUBLESHOOTING

Teledyne API analyzers use the RS-232 communications protocol to allow the instrument to be connected to a variety of computer-based equipment. RS-232 has been used for many years and as equipment has become more advanced, connections between various types of hardware have become increasingly difficult. Generally, every manufacturer observes the signal and timing requirements of the protocol very carefully.

Problems with RS-232 connections usually center around four general areas:

1. Incorrect cabling and connectors. See 3.3.1.8 for connector and pin-out information.
2. The BAUD rate and protocol are incorrectly configured. See Section 6.2.2.
3. If a modem is being used, additional configuration and wiring rules must be observed. See Section 8.3
4. Incorrect setting of the DTE – DCE Switch is set correctly. See 6.1.
5. Verify that cable (03596) that connects the serial COM ports of the CPU to J12 of the motherboard is properly seated

11.6.11.2. TROUBLESHOOTING ANALYZER/MODEM OR TERMINAL OPERATION

These are the general steps for troubleshooting problems with a modem connected to a Teledyne API analyzer.

1. Check cables for proper connection to the modem, terminal or computer.
2. Check to make sure the DTE-DCE is in the correct position as described in Section 6.1.
3. Check to make sure the set up command is correct (See Section 8.3)
4. Verify that the Ready to Send (RTS) signal is at logic high. The T803 sets pin 7 (RTS) to greater than 3 volts to enable modem transmission.
5. Make sure the BAUD rate, word length, and stop bit settings between modem and analyzer match, See Section 8.3.
6. Use the RS-232 test function to send “w” characters to the modem, terminal or computer; See Section 8.3.
7. Get your terminal, modem or computer to transmit data to the analyzer (holding down the space bar is one way); the green LED should flicker as the instrument is receiving data.
8. Make sure that the communications software or terminal emulation software is functioning properly.

Further help with serial communications is available in a separate manual “RS-232 Programming Notes” Teledyne API PN 013500000.

11.6.12. CO₂ SENSOR STATUS LED'S

There are Two LEDs located on the CO₂ sensor PCA.

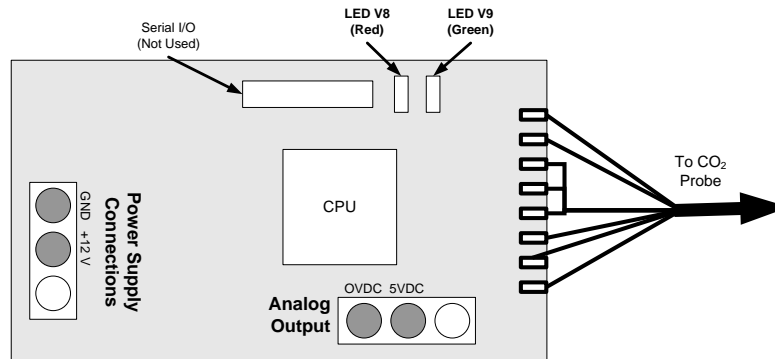

Figure 11-6: Location of Diagnostic LEDs on CO₂ Sensor PCA

- Normal Operation: V8 is not lit – V9 is Blinking
- Error State: Both LEDs are blinking.

Check to make sure that the cable to the CO₂ sensor is properly connected.

11.7. REPAIR PROCEDURES

This contains procedures that might need to be performed on rare occasions when a major component of the analyzer requires repair or replacement.

11.7.1. REPAIRING SAMPLE FLOW CONTROL ASSEMBLY

The critical flow orifice is housed in the flow control assembly (Teledyne API PN 001760400) located on the top of the optical bench. A sintered filter protects the jewel orifice so it is unusual for the orifice to need replacing, but if it does, or the filter needs replacement please use the following procedure (see the Spare Parts list in Appendix B for part numbers and kits):

1. Turn off power to the analyzer.
2. Locate the assembly attached to the sample pump, see Figure 3-5.
3. Disconnect the pneumatic connection from the flow assembly and the assembly from the pump.
4. Remove the fitting and the components as shown in the exploded view below.
5. Replace the o-rings (PN OR0000001) and the sintered filter (PN FL0000001).
6. If replacing the critical flow orifice itself (PN 000940700), make sure that the side with the colored window (usually red) is facing downstream to the flow gas flow.
7. Apply new Teflon[®] tape to the male connector threads
8. Re-assemble in reverse order.

9. After reconnecting the power and pneumatic lines, flow check the instrument as described in the Section 10.3.4.

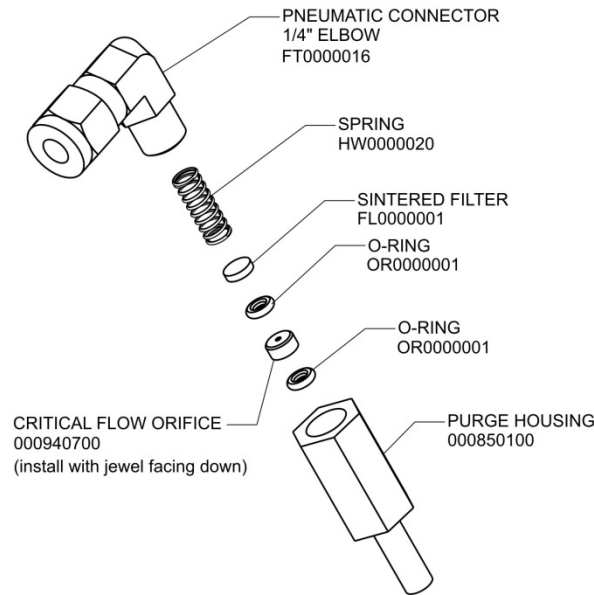

Figure 11-7: Critical Flow Restrictor Assembly / Disassembly

11.7.2. DISK-ON-MODULE REPLACEMENT PROCEDURE

ATTENTION

COULD DAMAGE INSTRUMENT AND VOID WARRANTY

Servicing of circuit components requires electrostatic discharge protection, i.e. ESD grounding straps, mats and containers. Failure to use ESD protection when working with electronic assemblies will void the instrument warranty. For more information on preventing ESD damage, refer to the manual, *Fundamentals of ESD, A Primer on Electro-Static Discharge*, downloadable from our website.

Replacing the Disk-on-Module (DOM) will cause loss of all DAS data; it may also cause loss of some instrument configuration parameters unless the replacement DOM carries the exact same firmware version. Whenever changing the version of installed software, the memory must be reset. Failure to ensure that memory is reset can cause the analyzer to malfunction, and invalidate measurements. After the memory is reset, the A/D converter must be re-calibrated, and all information collected in Step 1 below must be re-entered before the instrument will function correctly. Also, zero and span calibration should be performed.

1. Document all analyzer parameters that may have been changed, such as range, auto-cal, analog output, serial port and other settings before replacing the DOM
2. Turn off power to the instrument, fold down the rear panel by loosening the mounting screws.

3. When looking at the electronic circuits from the back of the analyzer, locate the Disk-on-Module in the right-most socket of the CPU board.
4. The DOM should carry a label with firmware revision, date and initials of the programmer.
5. Remove the nylon standoff clip that mounts the DOM over the CPU board, and lift the DOM off the CPU. Do not bend the connector pins.
6. Install the new Disk-on-Module, making sure the notch at the end of the chip matches the notch in the socket.
7. It may be necessary to straighten the pins somewhat to fit them into the socket. Press the chip all the way in.
8. Close the rear panel and turn on power to the machine.
9. If the replacement DOM carries a firmware revision, re-enter all of the setup information.

11.8. FREQUENTLY ASKED QUESTIONS (FAQ'S)

The following is a list from the Teledyne API's Technical Support Department of the most commonly asked questions relating to the analyzer.

QUESTION	ANSWER
Why does the ENTR button sometimes disappear on the Front Panel Display?	During certain types of adjustments or configuration operations, the ENTR button will disappear if you select a setting that is nonsensical (such as trying to set the 24-hour clock to 25:00:00) or out of the allowable range for that parameter (such as selecting a DAS HOLD OFF period of more than 20 minutes). Once you adjust the setting in question to an allowable value, the ENTR button will re-appear.
Why is the ZERO or SPAN button not displayed during calibration?	The analyzer disables these buttons when the expected span or zero value entered by the users is too different from the gas concentration actual measured value. This is to prevent the accidental recalibration of the analyzer to an out-of-range response curve. EXAMPLE: The span set point is 16% but gas concentration being measured is only 5%.
How do I enter or change the value of my Span Gas?	Press the CONC button found under the CAL button of the main SAMPLE display menus to enter the expected CO ₂ span concentration. See Section 9.2.3.1 or for more information.
Why does the analyzer not respond to span gas?	Section 11.4 has some possible answers to this question.
What shall I do if the concentration on the instrument's front panel display does not match the value recorded or displayed on my data logger even if both instruments are properly calibrated?	This most commonly occurs for one of the following reasons: - A difference in circuit ground between the analyzer and the data logger - A wiring problem or a scale problem with the input to the data logger. The analog outputs can be manually adjusted to compensate for either or both of these effects, see Section 5.10.5; - The analog outputs are not calibrated, which can happen after a firmware upgrade. - Both the electronic scale and offset of the analog outputs can be adjusted (see 5.10.3). Alternately, use the data logger itself as the metering device during calibrations procedures.
How do I perform a leak check?	See Section 10.3.3.

QUESTION	ANSWER
How do I measure the sample flow?	Sample flow is measured by attaching a calibrated rotameter, wet test meter, or other flow-measuring device to the sample inlet port when the instrument is operating. The sample flow should be 120 cm ³ /min ±10%. See Section 9.4.2.
What is the averaging time for this instrument?	The default averaging time, optimized for ambient pollution monitoring, is 60 seconds for stable concentrations and 10 seconds for rapidly changing concentrations; See 12.6.10 for more information.

11.9. TECHNICAL ASSISTANCE

If this manual and its troubleshooting / repair sections do not solve your problems, technical assistance may be obtained from:

Teledyne API, Technical Support
9970 Carroll Canyon Road
San Diego, California 92131-1106 USA

Phone: 800-324-5190 (toll free in North America)

Phone: +1 858-657-9800 (direct)

Fax: +1 858-657-9816

Email: sda_techsupport@teledyne.com

Website: <http://www.teledyne-api.com/>

Before you contact Teledyne API's Technical Support, fill out the problem report form in Appendix C, which is also available online for electronic submission at <http://www.teledyne-api.com/forms/>

12. PRINCIPLES OF OPERATION

The T803 analyzer is a microprocessor-controlled analyzer that determines the percent concentration of carbon dioxide (CO₂) and molecular oxygen (O₂) in a sample gas drawn through the instrument. It uses a paramagnetic sensor that relies on the relatively high reactivity of O₂ molecules to magnetic fields to generate a current that is proportional to the amount of O₂ present in the sensor chamber. The carbon dioxide measurement is achieved using infrared absorption technology.

Calibration of the instrument is performed in software and does not require physical adjustments to the instrument. During calibration the microprocessor measures the current state of both Sensor outputs and various other physical parameters of the instrument and stores them in memory. The microprocessor uses these calibration values, measurements made on the sample gas along with data regarding the current temperature and pressure of the gas to calculate the final concentrations.

12.1. O₂ SENSOR

12.1.1. MAGNETIC PROPERTIES OF O₂ GAS

Molecular oxygen, O₂, displays a particularly strong susceptibility to the effect of magnetic fields. This is due to the behavior of the electrons of the two oxygen atoms that make up the O₂ molecule.

When the electrons in an orbital are paired, they spin in opposite directions from each other thereby canceling any magnetic field effects. On the other hand, unpaired electrons, such as those of an O₂ molecule, spin in the same direction as each other, increasing the aggregate magnetic field.

12.1.2. PARAMAGNETIC MEASUREMENT OF O₂

The type of paramagnetic sensor used in the T803 analyzer is called a magneto-mechanical sensor. This type of sensor consists of a small dumbbell-shaped body (a sphere on either end) made of glass and filled with a gas of negative paramagnetic characteristic (in this case, N₂). The dumbbell body is suspended on a platinum fiber within the magnetic field of a permanent magnet, in such a way that it is free to rotate. Because the N₂ inside the spheres has a small opposite magnetic charge from the field of the permanent magnet, the dumbbell's resting (neutral) position is slightly deflected away from the strong point of the field.

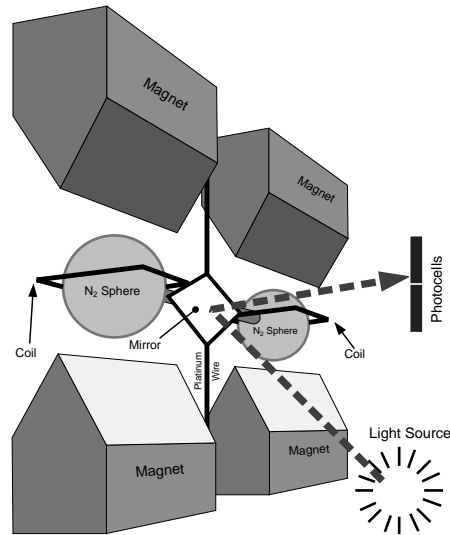

Figure 12-1: Paramagnetic O₂ Sensor Design

When sample gas containing oxygen flows into the magneto-mechanical sensor, the O₂ molecules are drawn toward the strong point of the magnetic field. This causes the N₂ filled spheres to deflect even more so that the suspended dumbbell body pivots on the platinum wire. The more O₂ present the further the dumbbell body is deflected from its neutral position.

The position of the dumbbell is detected by a pair of photocells that receive a light beam reflected from a mirror attached to the center of the dumbbell body. As the dumbbell body pivots, the angle of the reflected light beam on the photocells changes. The resulting potential difference creates a current.

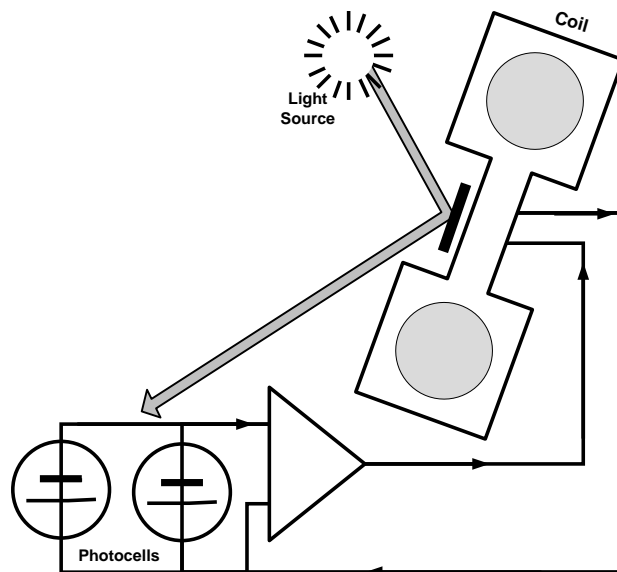

Figure 12-2: Paramagnetic O₂ Sensor Block Diagram

This current is passed to a feedback loop, which generates a second current to a wire winding (in effect, a small DC electric motor) mounted on the suspended mirror. The more O₂ present, the more the dumbbell and its attached mirror moves and the more current is needed to move the dumbbell back to its zero position. Finally, sensor measures the amount of current generated by the feedback control loop which is directly proportional to the concentration of oxygen within the sample gas mixture.

12.2. CO₂ SENSOR

12.2.1. NDIR MEASUREMENT OF CO₂

The CO₂ sensor is a silicon based Non-Dispersive Infrared (NDIR) sensor. It uses a single-beam, dual wavelength measurement method.

An infrared source at one end of the measurement chamber emits IR radiation into the sensor's measurement chamber where light at the 4.3 μm wavelength is partially absorbed by any CO₂ present. A special light filter called a Fabry-Perot Interferometer (FPI) is electronically tuned so that only light at the absorption wavelength of CO₂ is allowed to pass and be detected by the sensor's IR detector.

A reference measurement is made by electronically shifting the filter band pass wavelength so that no IR at the CO₂ absorption wavelength is let through.

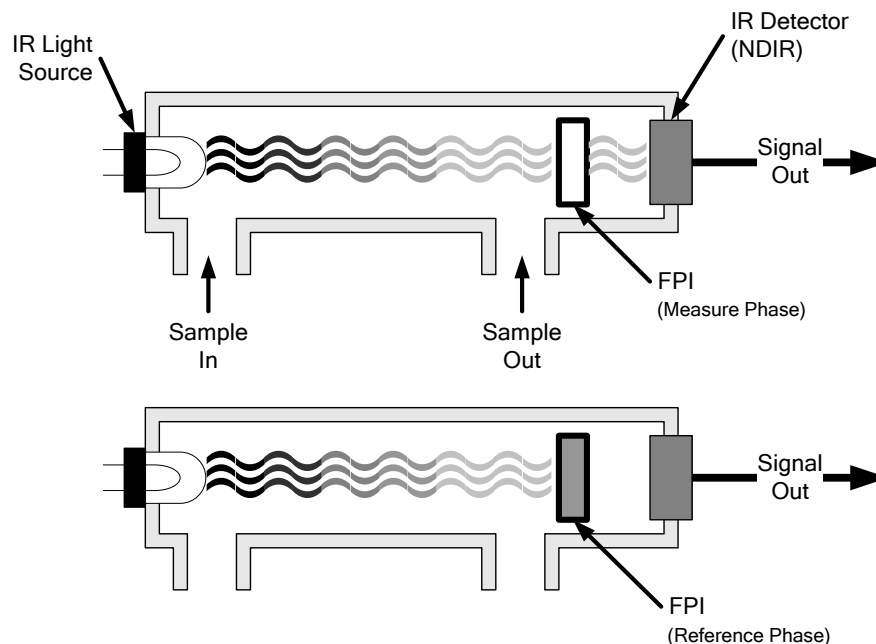

Figure 12-3. CO₂ Sensor Theory of Operation

The sensor computes the ratio between the reference signal and the measurement signal to determine the degree of light absorbed by CO₂ present in the sensor

chamber. This dual wavelength method of measuring CO₂ allows the instrument to compensate for ancillary effects like sensor aging and contamination.

12.3. OPERATION WITHIN THE T803 ANALYZER

Operationally, both the CO₂ and O₂ sensors are transparently integrated into the core analyzer operation. All functions can be viewed or accessed through the front panel.

- The CO₂ concentration is displayed in the upper right-hand corner, alternating with O₂ concentration.
- Test functions for the slope and offset of CO₂ and of O₂ are viewable from the front panel along with the analyzer's other test functions.
- Calibration of each sensor is performed via the front panel **CAL**. See Section 9 for more details.

Stability of each sensor can be viewed via the front panel (see Section 9).

12.3.1.1. ELECTRONIC OPERATION OF THE CO₂ SENSOR

The CO₂ PCA is powered by 12 VDC from the analyzer via the relay card, which outputs a 0-5 VDC analog signal to the analyzer's CPU via the motherboard that corresponds to the concentration of CO₂ measured by the probe.

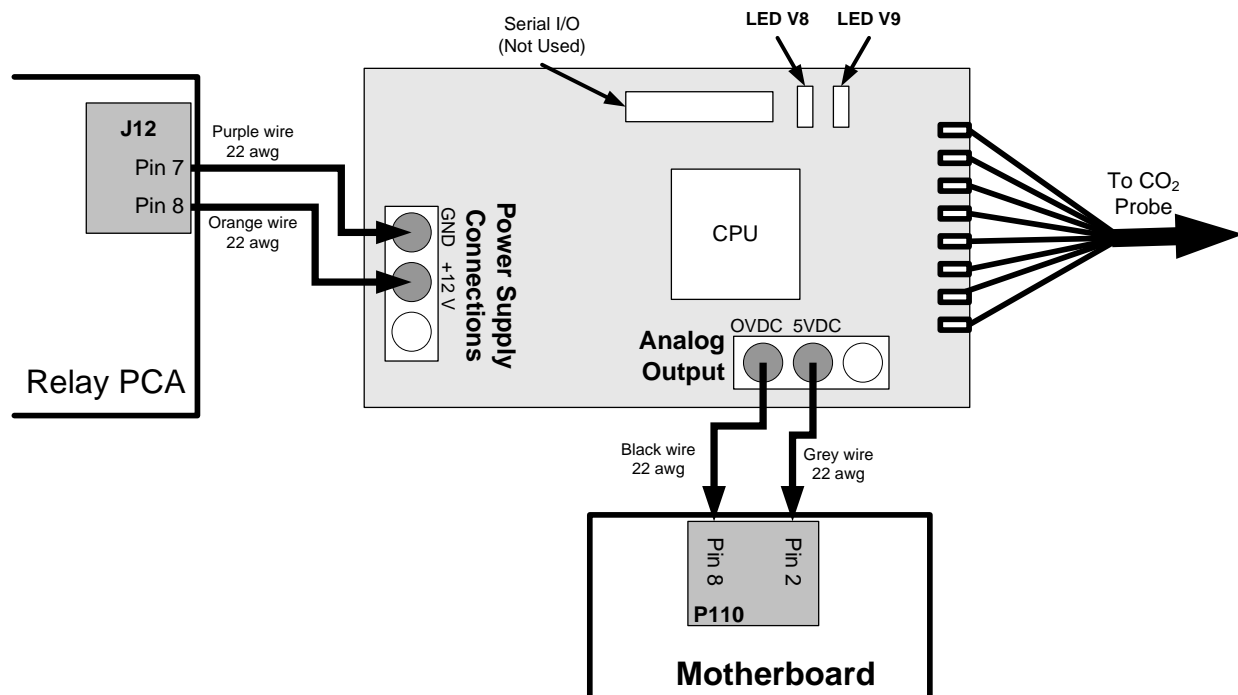

Figure 12-4. CO₂ Sensor PCA Layout and Electronic Connections

12.4. PNEUMATIC OPERATION



CAUTION

GENERAL SAFETY HAZARD

IT IS IMPORTANT THAT THE SAMPLE AIRFLOW SYSTEM IS BOTH LEAK-TIGHT AND NOT PRESSURIZED OVER AMBIENT PRESSURE.

Regular leak checks should be performed on the analyzer as described in the maintenance schedule, 10.1.

Procedures for correctly performing leak checks can be found in Section 10.3.3

In pneumatic operation an internal pump creates a vacuum that draws sample gas into the analyzer. Normally the analyzer is operated with its inlet near ambient pressure either because the sample is directly drawn at the inlet or a small vent is installed at the inlet when the sample is delivered under pressure. There are several advantages to this “pull through” configuration.

- First the pumping process heats and compresses the sample complicating the measurement process. Both heat and pressure affect the accuracy of gas measurements.
- Additionally, certain physical parts of the pump itself are made of materials that might chemically react with the sample gas.

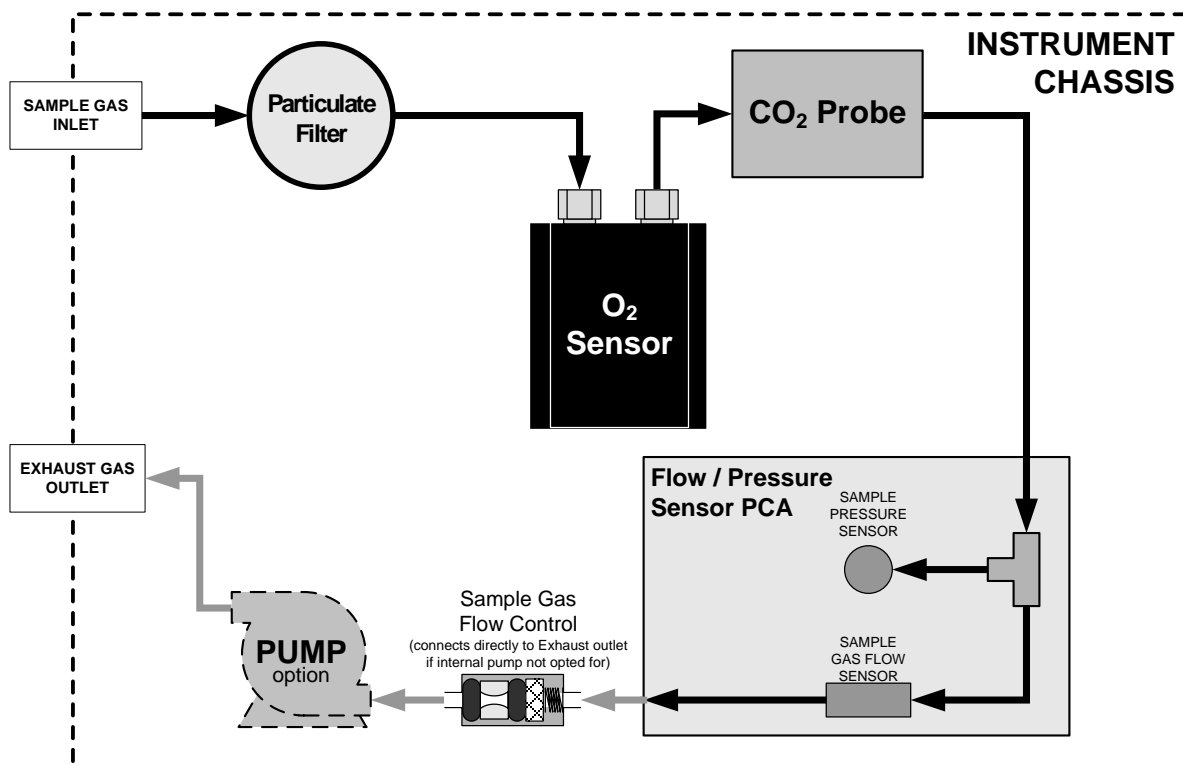

Figure 12-5: Internal Pneumatic Flow

12.5. FLOW RATE CONTROL

To maintain a constant flow rate of the sample gas through the instrument, the T803 uses a special flow control assembly located in the exhaust gas line just before the optional internal pump or connected to the rear panel if using an external pump. These assemblies consist of:

- A critical flow orifice.
- Two o-rings: Located just before and after the critical flow orifice, the o-rings seal the gap between the walls of assembly housing and the critical flow orifice.
- A spring: Applies mechanical force needed to form the seal between the o-rings, the critical flow orifice and the assembly housing.
- A sintered filter: Removes particulates to prevent clogging the orifice

12.5.1. CRITICAL FLOW ORIFICE

The most important component of this flow control assembly is the critical flow orifice.

Critical flow orifices are a remarkably simple way to regulate stable gas flow rates. They operate without moving parts by taking advantage of the laws of fluid dynamics. By restricting the flow of gas through the orifice, a pressure differential is created. This pressure differential combined with the action of the analyzer's pump draws the gas through the orifice.

As the pressure on the downstream side of the orifice (the pump side) continues to drop, the speed that the gas flows through the orifice continues to rise. Once the ratio of upstream pressure to downstream pressure is greater than 2:1, the velocity of the gas through the orifice reaches the speed of sound. As long as that ratio stays at least 2:1 the gas flow rate is unaffected by any fluctuations, surges, or changes in downstream pressure because such variations only travel at the speed of sound themselves and are therefore cancelled out by the sonic shockwave at the downstream exit of the critical flow orifice.

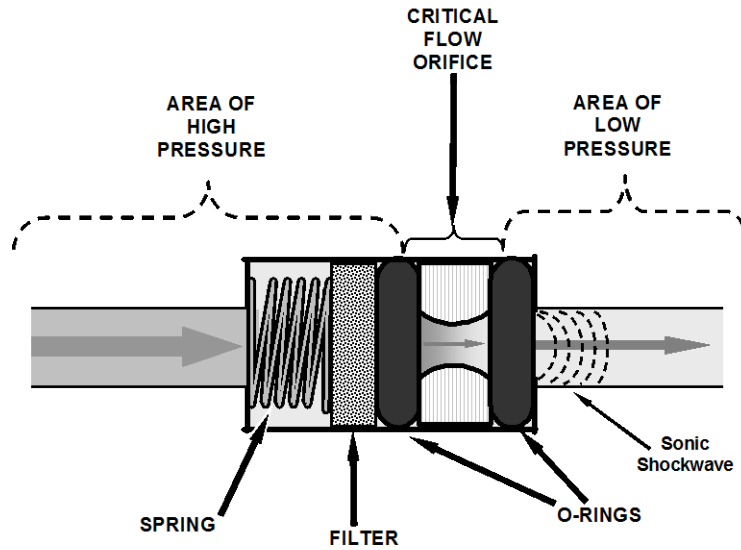

Figure 12-6: Flow Control Assembly & Critical Flow Orifice

The actual flow rate of gas through the orifice (volume of gas per unit of time), depends on the size and shape of the aperture in the orifice. The larger the hole, the more gas molecules, moving at the speed of sound, pass through the orifice. Because the flow rate of gas through the orifice is only related to the minimum 2:1 pressure differential and not absolute pressure the flow rate of the gas is also unaffected by degradations in pump efficiency due to age.

The critical flow orifice used in the T803 is designed to provide a flow rate of 120 cm³/min.

12.5.2. PARTICULATE FILTER

The T803 Analyzer comes equipped with a 47 mm diameter, Teflon, particulate filter with a 1 micron pore size. The filter is accessible through the front panel, which folds down to allow access, and should be changed according to the suggested maintenance schedule described in

12.5.3. PNEUMATIC SENSORS

12.5.3.1. SAMPLE PRESSURE SENSOR

An absolute value pressure transducer plumbed to the outlet of the sample chamber is used to measure sample pressure. The output of the sensor is used to compensate the concentration measurement for changes in ambient air pressure. This sensor is mounted to a printed circuit board with the sample flow sensor on the sample chamber; see the following section and Figure 3-5.

12.5.3.2. SAMPLE FLOW SENSOR

A thermal-mass flow sensor is used to measure the sample flow through the analyzer. The sensor is calibrated at the factory with ambient air or N₂, but can be calibrated to operate with samples consisting of other gases such as O₂. This

sensor is mounted to a printed circuit board with the Sample Pressure sensor on the sample chamber; see the previous section and Figure 3-5.

12.6. ELECTRONIC OPERATION

12.6.1. OVERVIEW

Figure 10-9 shows a block diagram of the major electronic components of the T803.

The core of the analyzer is a microcomputer (CPU) that controls various internal processes, interprets data, makes calculations, and reports results using specialized firmware developed by Teledyne API. It communicates with the user as well as receives data from and issues commands to a variety of peripheral devices via a separate printed circuit assembly called the motherboard.

The motherboard collects data, performs signal conditioning duties and routes incoming and outgoing signals between the CPU and the analyzer's other major components.

A variety of sensors report the physical and operational status of the analyzer's major components, again through the signal processing capabilities of the motherboard. These status reports are used as data for the gas concentration calculation and as trigger events for certain control commands issued by the CPU. They are stored in memory by the CPU and in most cases can be viewed but the user via the front panel display.

The CPU communicates with the user and the outside world in several ways

- Through the analyzer's touchscreen and LCD display over a clocked, digital, serial I/O bus (using a protocol called I²C);
- RS-232 & RS-485 Serial I/O channels via Ethernet, Modbus[®], APICOM or a terminal emulation program;
- Various DCV and DCA analog outputs, and
- Several sets of Digital I/O channels.

Finally, the CPU issues commands via a series of relays and switches (also over the I²C bus) located on a separate printed circuit assembly to control the function of key electromechanical devices such as heaters.

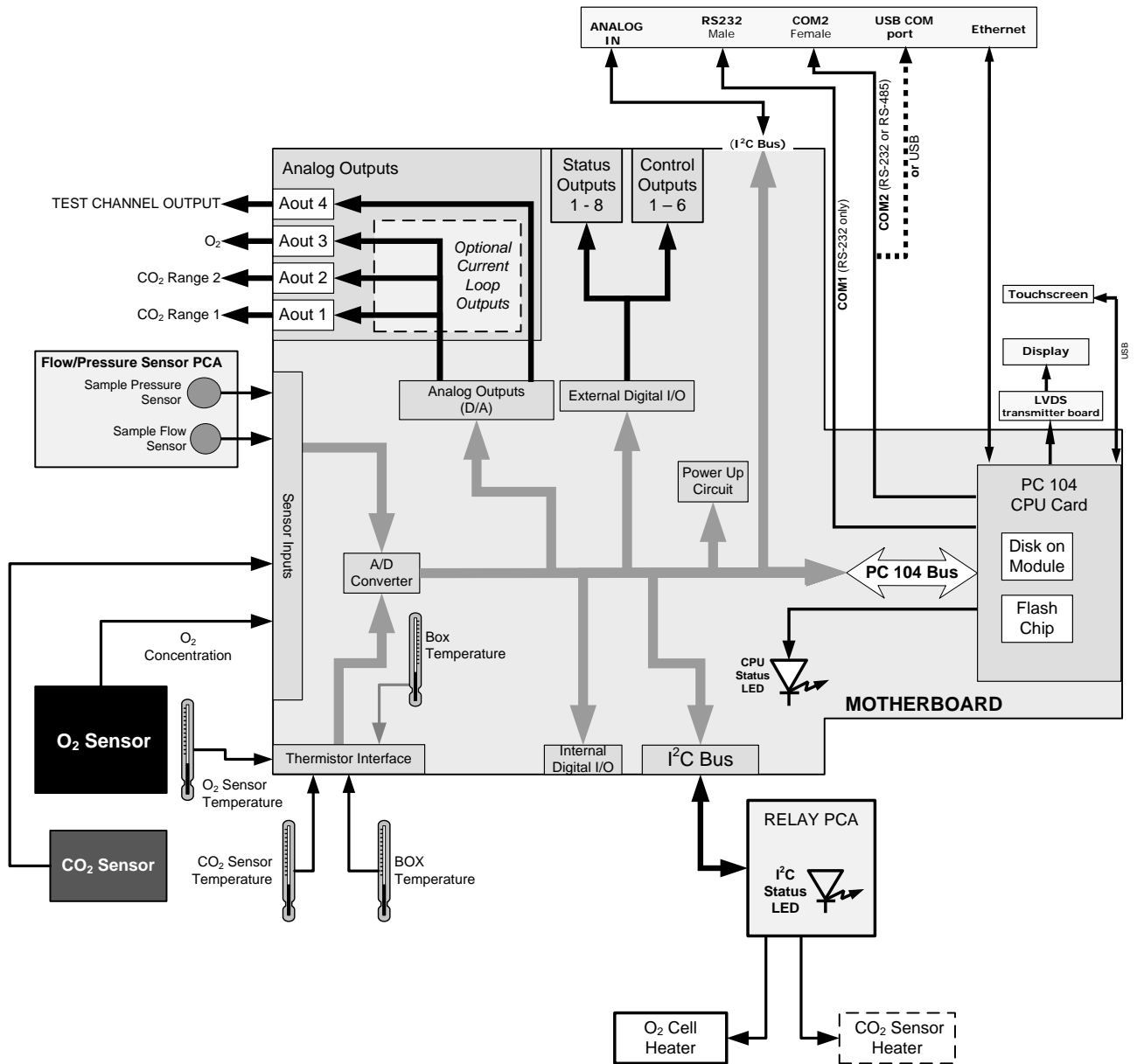

Figure 12-7: T803 Electronic Block Diagram

12.6.2. CENTRAL PROCESSING UNIT (CPU)

The unit’s CPU card (Figure 12-8) is installed on the motherboard located inside the rear panel. It is a low power (5 VDC, 720mA max), high performance, Vortex 86SX-based microcomputer running Windows CE. Its operation and assembly conform to the PC/104 specification.

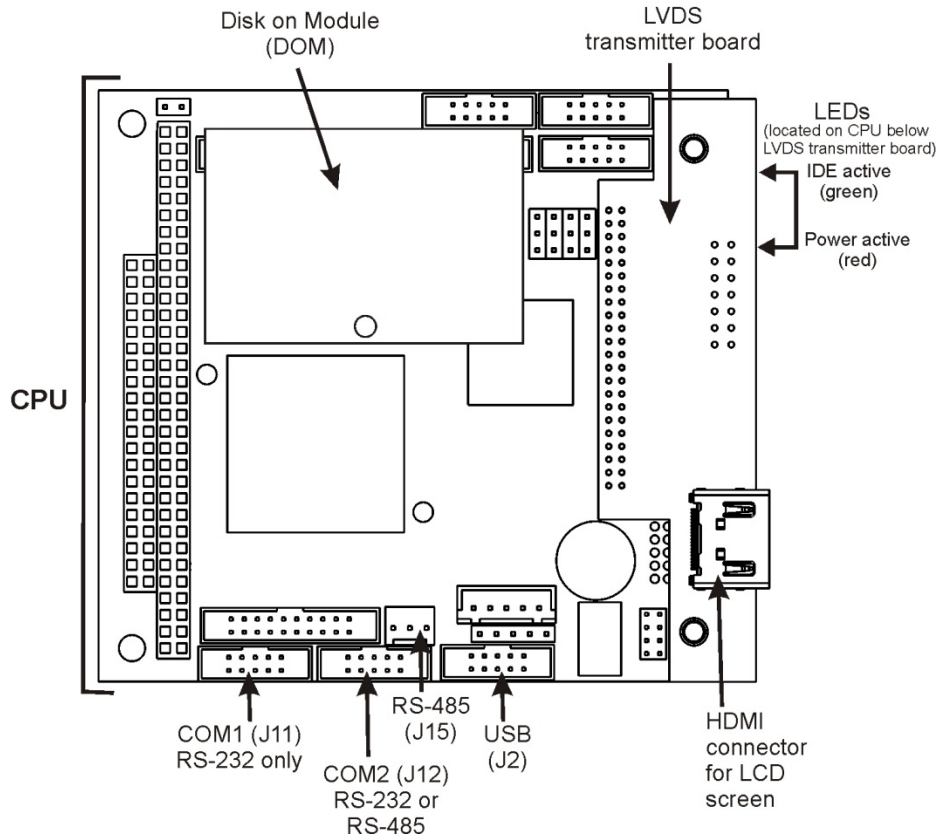

Figure 12-8. CPU Card

The CPU includes two types of non-volatile data storage: an embedded 2MB flash chip and a Disk on Module (DOM).

12.6.2.1. DISK-ON-MODULE (DOM)

The DOM is a 44-pin IDE flash disk with a storage capacity up to 128MB. It is used to store the computer's operating system, the Teledyne API firmware, and most of the operational data generated by the analyzer's internal data acquisition system (DAS - Section 7.1). The LEDs on the DOM indicate power and reading/writing to or from the DOM.

12.6.2.2. FLASH CHIP

This non-volatile, embedded flash chip includes 2MB of storage for calibration data as well as a backup of the analyzer configuration. Storing these key data on a less heavily accessed chip significantly decreases the chance of data corruption.

In the unlikely event that the flash chip should fail, the analyzer will continue to operate with just the DOM. However, all configuration information will be lost, requiring the unit to be recalibrated.

12.6.3. RELAY BOARD

The CPU issues commands via a series of relays and switches located on a separate printed circuit assembly, called the relay PCA, to control the function of key electromechanical devices such as heaters. The relay PCA receives instructions in the form of digital signals over the I²C bus, interprets these digital instructions and activates its various switches and relays appropriately.

The relay PCA is located in the right-rear quadrant of the analyzer and is mounted vertically on the backside of the same bracket as the instrument's DC power supplies.

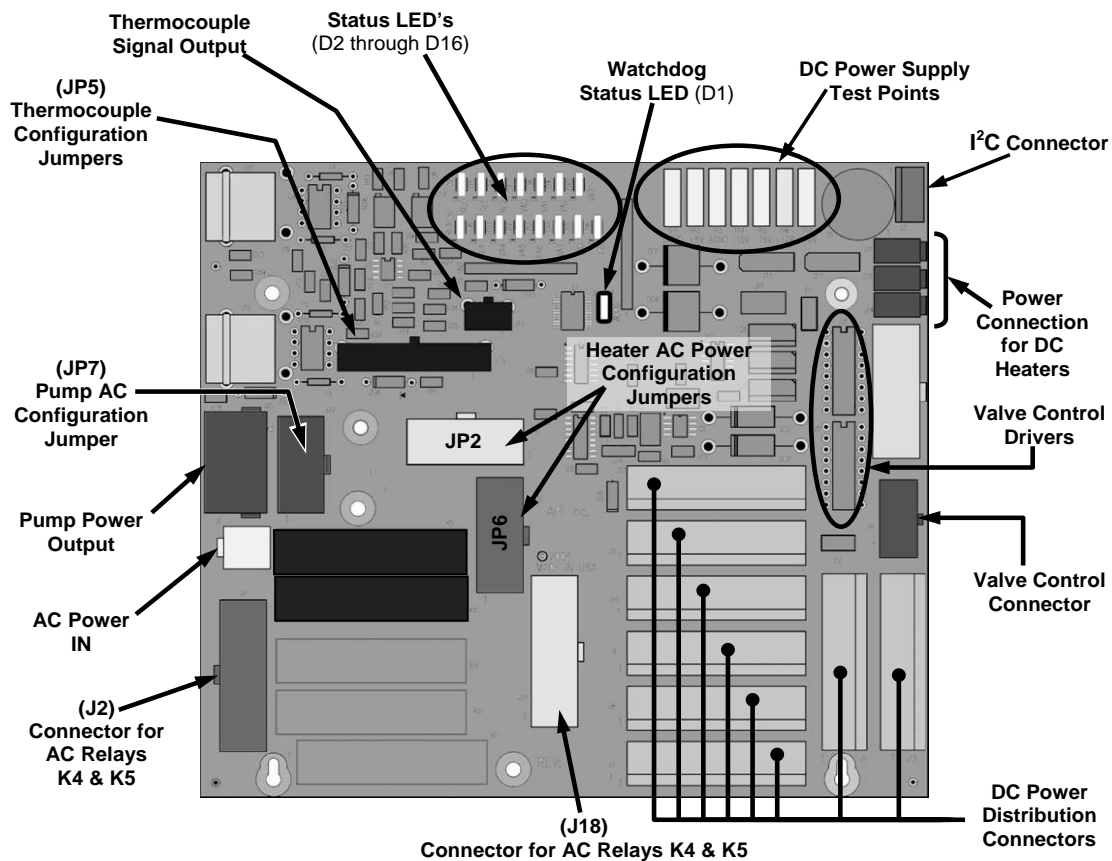

Figure 12-9: Relay PCA Layout (PN 04135)

CAUTION

ELECTRICAL SHOCK HAZARD



Only those relays actually required by the configuration of the T803 are populated.

A protective retainer plate is installed over the AC power relays to keep them securely seated in their sockets and prevent accidental contact with those sockets that are not populated see Figure 12-10).

Never remove this retainer while the instrument is plugged in and turned on. The contacts of the AC relay sockets beneath the shield carry high AC voltages even when no relays are present.

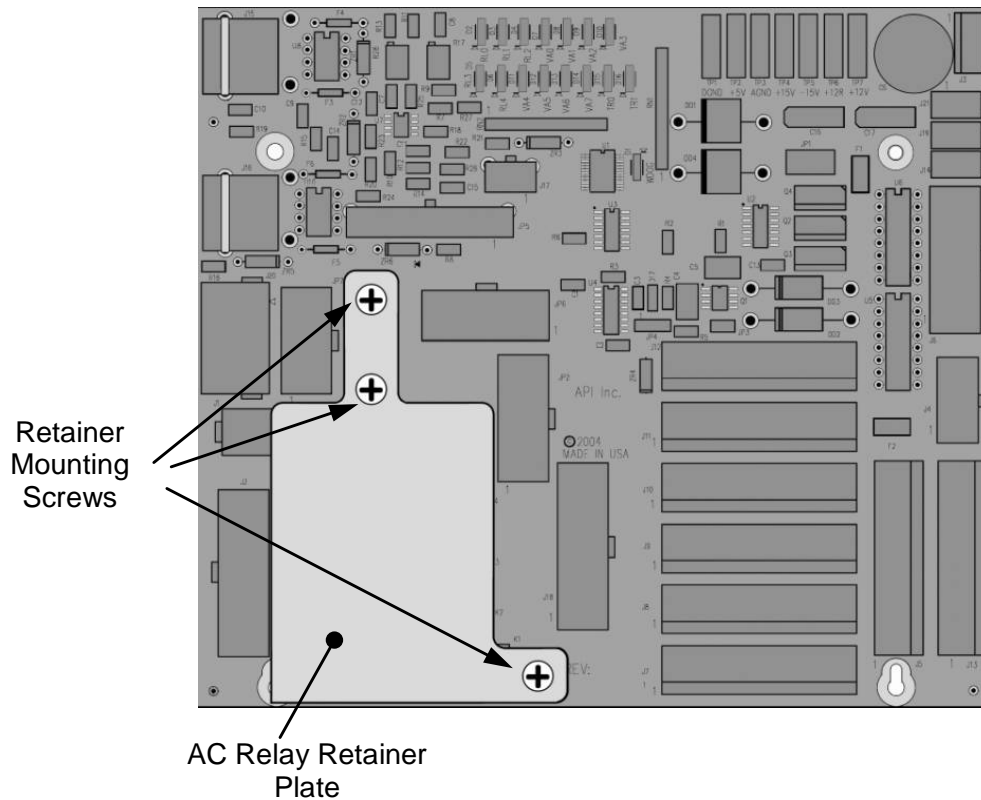

Figure 12-10: Relay PCA with AC Relay Retainer in Place

12.6.3.1. STATUS LEDs

LEDs located on the Analyzer's relay PCA, show the current status of various control functions performed by the relay PCA. The three that are used in the T803 are described in Table 12-1, and their locations are illustrated in Figure 12-11.

Table 12-1: Relay PCA Status LEDs

LED	Color	Function	Status When LED Lit (Energized State)	Status When LED Unlit (Default State)
D1	Red	Watchdog Circuit	Cycles ON/OFF every 3 Seconds under direct control of the analyzer's CPU.	
D2-D4	SPARE			
D5	Yellow	CO ₂ Sensor Cell heater	Heating	Not Heating
D6	Yellow	O ₂ Sensor heater	Heating	Not Heating
D7 ²	Green			
D8 ²	Green			
D9 ²	Green			
D10 ²	Green			
D11 - 16	SPARE			

² Not Used.

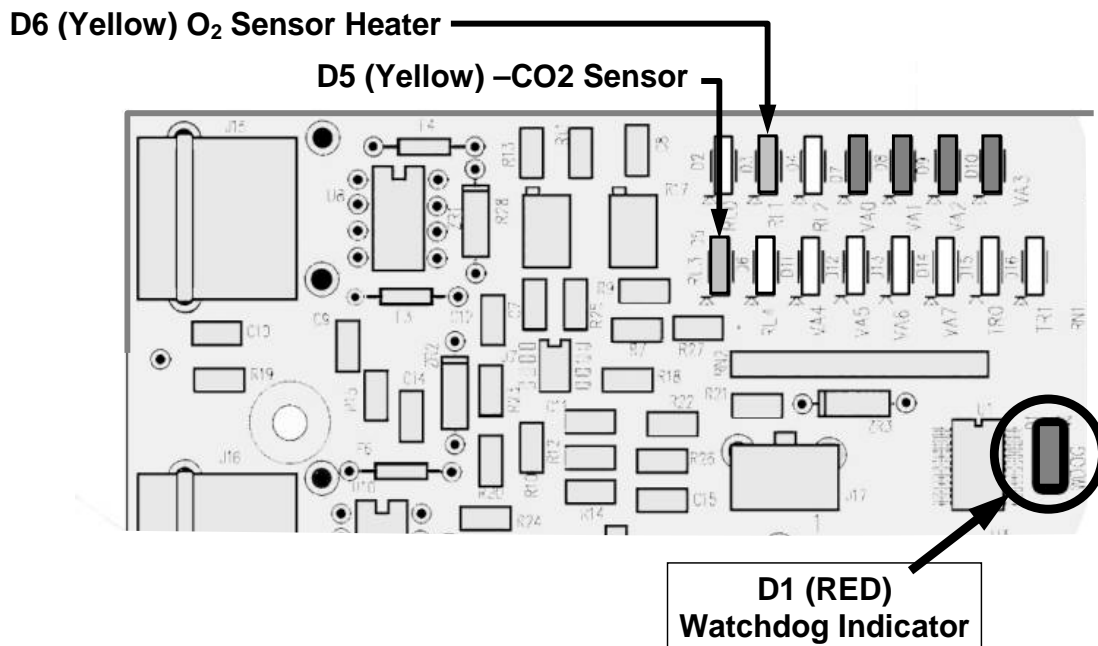

Figure 12-11: Status LED Locations – Relay PCA

12.6.3.2. WATCHDOG CIRCUITRY

The most important of the status LEDs on the relay board is the red I²C Bus watch-dog LED. It is controlled directly by the analyzer's CPU over the I²C Bus. Special circuitry on the relay PCA watches the status of D1. Should this LED ever stay ON or OFF for 30 seconds, indicating that the CPU or I²C bus has stopped functioning, this Watchdog Circuit automatically shuts off all heaters.

12.6.4. HEATER CONTROL

12.6.4.1. TEMPERATURE CONTROL

At low magnetic field strengths levels, paramagnetic molecules follow Curie's law to good approximation, which indicates that the susceptibility of paramagnetic materials is inversely proportional to their temperature.

To minimize the effects of temperature variations on the O₂ concentration measurement the parametric sensor is raised to a high temperature level, 50°C. A cartridge heater implanted into the sensor is the heat source. The temperature of the sensor is measured by a thermistor also inserted into the sensor body.

12.6.5. MOTHERBOARD

This printed circuit assembly provides a multitude of functions including, A/D conversion, digital input/output, PC-104 to I²C translation, temperature sensor signal processing, and serves as a pass-through for the RS-232 and RS-485 signals.

12.6.5.1. A TO D CONVERSION

Analog signals, such as the voltages received from the analyzer's various sensors, are converted into digital signals that the CPU can understand and manipulate by the analog to digital converter (A/D). Under the control of the CPU, this functional block selects a particular signal input (e.g. BOX TEMP) and then converts the selected voltage into a digital word.

The A/D consists of a voltage-to-frequency (V-F) converter, a programmable logic device (PLD), three multiplexers, several amplifiers and some other associated devices. The V-F converter produces a frequency proportional to its input voltage. The PLD counts the output of the V-F during a specified time period, and sends the result of that count, in the form of a binary number, to the CPU.

The A/D can be configured for several different input modes and ranges but in the T803 the A/D is used in uni-polar mode with a +5 V full scale. The converter includes a 1% over and under-range. This allows signals from -0.05 V to +5.05 V to be fully converted.

For calibration purposes, two reference voltages are supplied to the A/D converter: Reference Ground and +4.096 VDC. During calibration, the device measures these two voltages, outputs their digital equivalent to the CPU. The CPU uses these values to compute the converter's offset and slope and uses these factors for subsequent conversions.

See Section 5.10.3 for instructions on performing this calibration.

12.6.5.2. SENSOR INPUTS

The key analog sensor signals are coupled to the A/D through the master multiplexer from two connectors on the motherboard. 100K terminating resistors on each of the inputs prevent cross talk from appearing on the sensor signals.

SAMPLE PRESSURE AND FLOW

These are analog signals from two sensors that measure the pressure and flow rate of the gas stream at the outlet of the sample chamber. This information is used in two ways. First, the sample pressure is used by the CPU to calculate O₂ Concentration. Second, the pressure and flow rate are monitored as a test function to assist the user in predicting and troubleshooting failures.

12.6.5.3. THERMISTOR INTERFACE

This circuit provides excitation, termination and signal selection for several negative-coefficient, thermistor temperature sensors located inside the analyzer; there is a thermistor for the O₂ sample chamber housing, which reports the current temperature of the chamber housing to the CPU as part of the bench heater control loop. Another thermistor, attached to the motherboard, measures the analyzer's inside temperature (box temperature). This information is stored by the CPU and can be viewed by the user for troubleshooting purposes via the front panel display (See Section 11.1.2).

12.6.5.4. ANALOG OUTPUTS

The analyzer comes equipped with four analog outputs: **A1**, **A2**, **A3** and **A4**. The type of data and electronic performance of these outputs are configurable by the user. (see Section 5.10). All four analog outputs are connected back to the A/D converter through a Loop-back circuit. This permits the voltage outputs to be calibrated by the CPU without need for any additional tools or fixtures.

12.6.5.5. EXTERNAL DIGITAL I/O

This External Digital I/O performs status outputs and control inputs.

STATUS OUTPUTS

Logic-Level voltages are output through an optically isolated 8-pin connector located on the rear panel of the analyzer. These outputs convey good/bad and on/off information about certain analyzer conditions. They can be used to interface with certain types of programmable devices (See Section 3.3.1.4).

CONTROL INPUTS

By applying +5VDC power supplied from an external source such as a PLC or Data logger (See Section 3.3.1.6), Zero and Span calibrations can be initiated by contact closures on the rear panel.

12.6.6. I²C DATA BUS

An I²C data bus is used to communicate data and commands between the CPU and the touchscreen interface and the relay board. I²C is a two-wire, clocked, digital serial I/O bus that is used widely in commercial and consumer electronic systems. A transceiver on the motherboard converts data and control signals from the PC-104 bus to I²C. The data is then fed to the keyboard/display interface and finally onto the relay board.

Interface circuits on the keyboard/display interface and relay boards convert the I²C data to parallel inputs and outputs. An additional, interrupt line from the keyboard to the motherboard allows the CPU to recognize and service key presses on the keyboard.

POWER UP CIRCUIT

This circuit monitors the +5V power supply during start-up and sets the Analog outputs, external digital I/O ports, and I²C circuitry to specific values until the CPU boots and the instrument software can establish control.

12.6.7. POWER SUPPLY / CIRCUIT BREAKER

The analyzer operates on 100 VAC, 115 VAC or 230 VAC power at either 50Hz or 60Hz. Individual units are set up at the factory to accept any combination of these five attributes. As illustrated in Figure 12-12, power enters the analyzer through a standard IEC 320 power receptacle located on the rear panel of the instrument. From there it is routed through the On/Off switch located in the lower right corner of the Front Panel. A 6.75 Amp circuit breaker is built into the ON/OFF Switch.

AC power is distributed directly to the sample gas pump.

AC Line power is stepped down and converted to DC power by two DC power supplies. One supplies +12 VDC, while a second supply provides +5 VDC and ± 15 VDC for logic and analog circuitry. All DC voltages are distributed via the relay board.



CAUTION GENERAL SAFETY HAZARD

Should the AC power circuit breaker trip, investigate and correct the condition causing this situation before turning the analyzer back on.

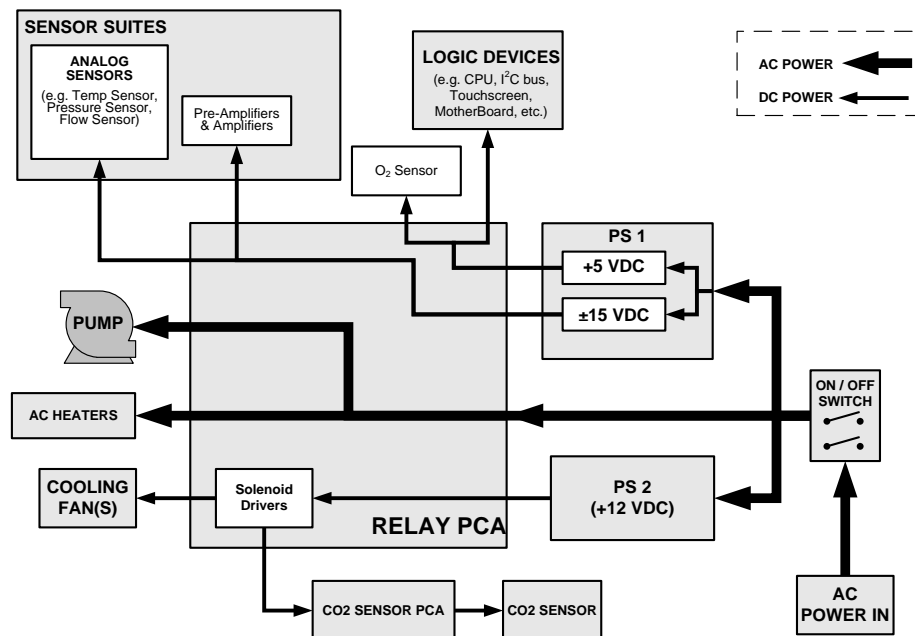

Figure 12-12: Power Distribution Block Diagram

12.6.8. FRONT PANEL TOUCHSCREEN/DISPLAY INTERFACE

Users can input data and receive information directly through the front panel touchscreen display. The LCD display is controlled directly by the CPU board. The touchscreen is interfaced to the CPU by means of a touchscreen controller that connects to the CPU via the internal USB bus and emulates a computer mouse.

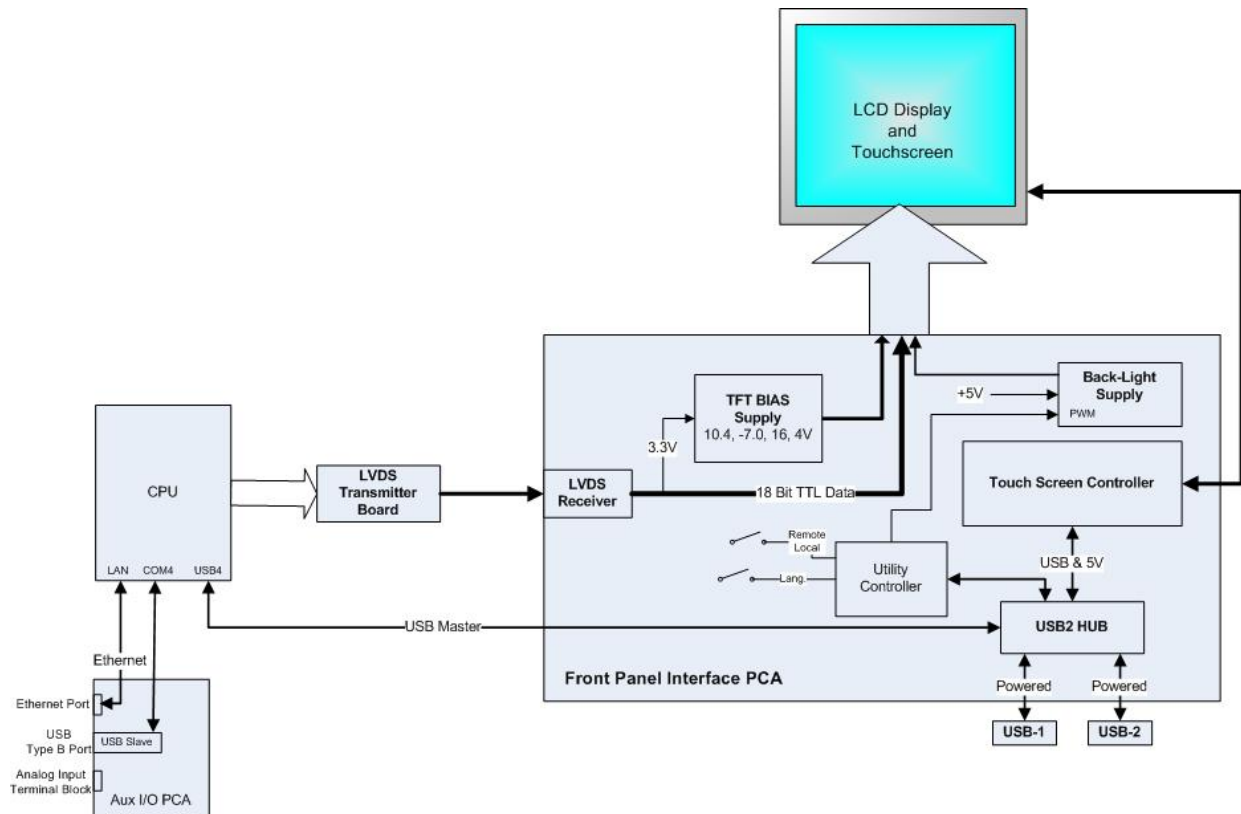

Figure 12-13: Front Panel and Display Interface Block Diagram

12.6.8.1. LVDS TRANSMITTER BOARD

The LVDS (low voltage differential signaling) transmitter board converts the parallel display bus to a serialized, low voltage, differential signal bus in order to transmit the video signal to the LCD interface PCA.

12.6.8.2. FRONT PANEL TOUCHSCREEN/DISPLAY INTERFACE PCA

The front panel touchscreen/display interface PCA controls the various functions of the display and touchscreen. For driving the display it provides connection between the CPU video controller and the LCD display module. This PCA also contains:

- power supply circuitry for the LCD display module
- a USB hub that is used for communications with the touchscreen controller and the two front panel USB device ports
- the circuitry for powering the display backlight

12.6.9. SOFTWARE OPERATION

The T803 Analyzer is at its heart a high performance, 386-based microcomputer running MS-DOS. Inside the DOS shell, special software developed by Teledyne API interprets user commands via the various interfaces, performs procedures and tasks, stores data in the CPU's various memory devices and calculates the concentration of the sample gas.

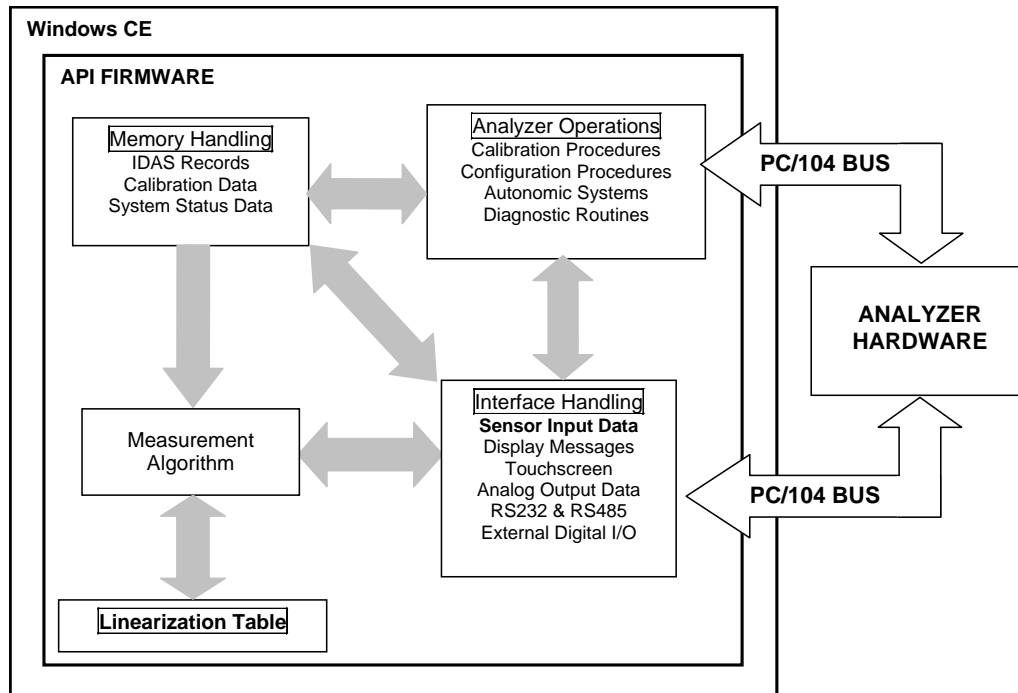

Figure 12-14: Basic Software Operation

12.6.10. ADAPTIVE FILTER

Unlike other analyzers that average the output signal over a fixed time period, the T803 averages over a set number of samples, where each sample is 1 second. This technique is known as boxcar averaging. During operation, the software automatically switches between two different length filters based on the conditions at hand. Once triggered, the short filter remains engaged for a fixed time period to prevent chattering.

Two conditions must be simultaneously met to switch to the short filter. First, the instantaneous concentration must exceed the average in the long filter by a fixed amount. Second, the instantaneous concentration must exceed the average in the long filter by a portion, or percentage, of the average in the long filter.

If necessary, these boxcar lengths as well as the threshold levels can be altered but with corresponding tradeoffs in rise time and signal-to-noise ratio (contact Teledyne API Technical Support for more information).

12.6.11. CALIBRATION - SLOPE AND OFFSET

Calibration of the analyzer is performed exclusively in software.

During instrument calibration the user enters expected values for span via the front panel touchscreen; values are not entered during a zero operation, commanding the instrument to make readings of calibrated sample gases for both levels. The readings taken are adjusted, linearized, and compared to the expected values. With this information the software computes values for instrument slope and offset and stores these values in memory for use in calculating concentrations of the sample gas.

The instrument slope and offset values recorded during the last calibration are available for viewing from the front panel (See Section 3.5.1)

12.6.12. TEMPERATURE AND PRESSURE COMPENSATION

Changes in ambient pressure can have a noticeable effect on the CO₂ and O₂ concentration calculations. To account for this, the T803 software includes a feature which allows the instrument to compensate both CO₂ and O₂ calculations based on changes in ambient pressure. Both sensors are housed inside temperature controlled manifolds. This minimizes temperature effects on the measured concentrations.

12.6.13. INTERNAL DATA ACQUISITION SYSTEM (DAS)

The DAS is designed to implement predictive diagnostics that stores trending data for users to anticipate when an instrument will require service. Large amounts of data can be stored in non-volatile memory and retrieved in plain text format for further processing with common data analysis programs. The DAS has a consistent user interface in all Teledyne API analyzers. New data parameters and triggering events can be added to the instrument as needed.

Depending on the sampling frequency and the number of data parameters the DAS can store several months of data, which are retained even when the instrument is powered off or a new firmware is installed. The DAS permits users to access the data through the instrument's front panel or the remote interface. The latter can automatically download stored data for further processing. For information on using the DAS, refer to Section 7.1

This page intentionally left blank.

GLOSSARY

Note: Some terms in this glossary may not occur elsewhere in this manual.

Term	Description/Definition
10BaseT	an Ethernet standard that uses twisted ("T") pairs of copper wires to transmit at 10 megabits per second (Mbps)
100BaseT	same as 10BaseT except ten times faster (100 Mbps)
APICOM	name of a remote control program offered by Teledyne-API to its customers
ASSY	<i>Assembly</i>
CAS	<i>Code-Activated Switch</i>
CD	<i>Corona Discharge</i> , a frequently luminous discharge, at the surface of a conductor or between two conductors of the same transmission line, accompanied by ionization of the surrounding atmosphere and often by a power loss
CE	<i>Converter Efficiency</i> , the percentage of light energy that is actually converted into electricity
CEM	<i>Continuous Emission Monitoring</i>
Chemical formulas that may be included in this document:	
CO ₂	carbon dioxide
C ₃ H ₈	propane
CH ₄	methane
H ₂ O	water vapor
HC	general abbreviation for hydrocarbon
HNO ₃	nitric acid
H ₂ S	hydrogen sulfide
NO	nitric oxide
NO ₂	nitrogen dioxide
NO _x	nitrogen oxides, here defined as the sum of NO and NO ₂
NO _y	nitrogen oxides, often called odd nitrogen: the sum of NO _x plus other compounds such as HNO ₃ (definitions vary widely and may include nitrate (NO ₃), PAN, N ₂ O and other compounds as well)
NH ₃	ammonia
O ₂	molecular oxygen
O ₃	ozone
SO ₂	sulfur dioxide

Term	Description/Definition
cm ³	metric abbreviation for <i>cubic centimeter</i> (replaces the obsolete abbreviation "cc")
CPU	<i>Central Processing Unit</i>
DAC	<i>Digital-to-Analog Converter</i>
DAS	<i>Data Acquisition System</i>
DCE	<i>Data Communication Equipment</i>
DFU	<i>Dry Filter Unit</i>
DHCP	<i>Dynamic Host Configuration Protocol</i> . A protocol used by LAN or Internet servers to automatically set up the interface protocols between themselves and any other addressable device connected to the network
DIAG	<i>Diagnostics</i> , the diagnostic settings of the analyzer.
DOM	<i>Disk On Module</i> , a 44-pin IDE flash drive with up to 128MB storage capacity for instrument's firmware, configuration settings and data
DOS	<i>Disk Operating System</i>
DRAM	<i>Dynamic Random Access Memory</i>
DR-DOS	<i>Digital Research DOS</i>
DTE	<i>Data Terminal Equipment</i>
EEPROM	also referred to as a FLASH chip or drive
ESD	<i>Electro-Static Discharge</i>
ETEST	<i>Electrical Test</i>
Ethernet	a standardized (IEEE 802.3) computer networking technology for local area networks (LANs), facilitating communication and sharing resources
FEP	<i>Fluorinated Ethylene Propylene</i> polymer, one of the polymers that Du Pont markets as <i>Teflon</i> [®]
Flash	non-volatile, solid-state memory
FPI	<i>Fabry-Perot Interferometer</i> a special light filter typically made of a transparent plate with two reflecting surfaces or two parallel, highly reflective mirrors
GFC	<i>Gas Filter Correlation</i>
I ² C bus	a clocked, bi-directional, serial bus for communication between individual analyzer components
IC	<i>Integrated Circuit</i> , a modern, semi-conductor circuit that can contain many basic components such as resistors, transistors, capacitors etc in a miniaturized package used in electronic assemblies
IP	<i>Internet Protocol</i>

Term	Description/Definition
IZS	<i>Internal Zero Span</i>
LAN	<i>Local Area Network</i>
LCD	<i>Liquid Crystal Display</i>
LED	<i>Light Emitting Diode</i>
LPM	<i>Liters Per Minute</i>
MFC	<i>Mass Flow Controller</i>
M/R	<i>Measure/Reference</i>
MOLAR MASS	<p>the mass, expressed in grams, of 1 mole of a specific substance. Conversely, one mole is the amount of the substance needed for the molar mass to be the same number in grams as the atomic mass of that substance.</p> <p>EXAMPLE: The atomic weight of Carbon is 12 therefore the molar mass of Carbon is 12 grams. Conversely, one mole of carbon equals the amount of carbon atoms that weighs 12 grams.</p> <p>Atomic weights can be found on any Periodic Table of Elements.</p>
NDIR	<i>Non-Dispersive Infrared</i>
NIST-SRM	<i>National Institute of Standards and Technology - Standard Reference Material</i>
PC	<i>Personal Computer</i>
PCA	<i>Printed Circuit Assembly, the PCB with electronic components, ready to use</i>
PC/AT	<i>Personal Computer / Advanced Technology</i>
PCB	<i>Printed Circuit Board, the bare board without electronic component</i>
PFA	<i>Per-Fluoro-Alkoxy, an inert polymer; one of the polymers that Du Pont markets as Teflon[®]</i>
PLC	<i>Programmable Logic Controller, a device that is used to control instruments based on a logic level signal coming from the analyzer</i>
PLD	<i>Programmable Logic Device</i>
PLL	<i>Phase Lock Loop</i>
PMT	<i>Photo Multiplier Tube, a vacuum tube of electrodes that multiply electrons collected and charged to create a detectable current signal</i>
P/N (or PN)	<i>Part Number</i>
PSD	<i>Prevention of Significant Deterioration</i>
PTFE	<i>Poly-Tetra-Fluoro-Ethylene, a very inert polymer material used to handle gases that may react on other surfaces; one of the polymers that Du Pont markets as Teflon[®]</i>
PVC	<i>Poly Vinyl Chloride, a polymer used for downstream tubing</i>

Term	Description/Definition
Rdg	Reading
RS-232	specification and standard describing a serial communication method between DTE (Data Terminal Equipment) and DCE (Data Circuit-terminating Equipment) devices, using a maximum cable-length of 50 feet
RS-485	specification and standard describing a binary serial communication method among multiple devices at a data rate faster than RS-232 with a much longer distance between the host and the furthest device
SAROAD	<i>Storage and Retrieval of Aerometric Data</i>
SLAMS	<i>State and Local Air Monitoring Network Plan</i>
SLPM	<i>Standard Liters Per Minute</i> of a gas at standard temperature and pressure
STP	<i>Standard Temperature and Pressure</i>
TCP/IP	<i>Transfer Control Protocol / Internet Protocol</i> , the standard communications protocol for Ethernet devices
TEC	<i>Thermal Electric Cooler</i>
TPC	<i>Temperature/Pressure Compensation</i>
USB	<i>Universal Serial Bus</i> : a standard connection method to establish communication between peripheral devices and a host controller, such as a mouse and/or keyboard and a personal computer or laptop
VARS	<i>Variables</i> , the variable settings of the instrument
V-F	<i>Voltage-to-Frequency</i>
Z/S	<i>Zero / Span</i>

INDEX

A

AC Power 60 Hz, 31
AIN, 94
ALRM, 58, 96
ANALOG CAL WARNING, 49
Analog Inputs, 94
Analog Outputs, 32, 33, 57, 58, 60, 61, 76
 Ain Calibration, 94
 CONC1, 51
 CONC2, 51
 Configuration & Calibration, 58, 81, 82, 83, 84, 86, 88, 90, 91, 94
 Automatic, 25, 57, 84
 Manual-Current Loop, 87, 89
 Manual-Voltage, 85
 Electrical Connections, 32
 Electronic Range Selection, 80
 Output Loop Back, 213
 Over-Range Feature, 90
 Pin Assignments, 32
 Recorder Offset, 91
 Reporting Range, 57
 Test Channel, 92
 Chassis Temp, 92
 NONE, 92
 SAMPLE FLOW, 92
 SAMPLE PRESS, 92
Analyzer Operating Modes, 54
APICOM, 100, 125, 145, 147, 157, 171
 and DAS System, 127, 142, 144, 145
 configuration failure, 138
 front panel edit, 131
 Interface Example, 144
 Software Download, 145, 147
 user manual, 145
ATIMER, 127, 131, 132
AUTO, 62
AutoCal, 54, 56, 82

B

Baud Rate, 115
BOX TEMP, 49, 56, 180, 188
BOX TEMP WARNING, 49, 178

C

Cal Gas Line, 46
CAL HOLD OFF, 35, 74, 127, 141
CAL Mode
 Remote, 36
CALDAT, 128
Calibration
 AIN, 94
 Analog Outputs, 25, 57, 84
 Analog Outputs

 Current Loop, 87, 89
 Voltage, 85
Calibration Checks, 155, 158
Calibration Current Meter, 87
Calibration Gases, 156
 Span Gas, 160
 Standard Reference Materials (SRM's)
 CO Span Gas, 45
 Zero Air, 44, 156
Calibration Voltmeter, 85
CANNOT DYN SPAN, 49, 122, 178
CANNOT DYN ZERO, 49, 122, 178
Clock, 71
CLOCK_ADJ, 74
CO₂, 56, 119, 157
 AUTO MODE, 66
CO₂ CAL
 Remote, 36
CO₂ CELL TEMP, 56
CO₂ CELL TEMP WARNING, 49
CO₂ CONC ALRM1 WARNING, 49
CO₂ CONC ALRM2 WARNING, 49
CO₂ OFFSET, 56
CO₂ Sensor, 78, 201, 202
 operation, 202
 Troubleshooting, 195
CO₂ SLOPE, 56
COMM Ports, 99, 100, 115
 and DAS System, 140
 Baud Rate, 102
 COM1, 117
 Default Settings, 39
 COM2, 40, 100, 117
 Default Settings, 39
 Communication Modes, 99, 100
 DCE – DTE, 99
 Machine ID, 43, 104
 Parity, 100, 115
 RS-485, 101
 Security, 151
 testing, 103
Communication
 External, 58
CONC, 127, 131
CONC ALRM1 WARNING, 122
CONC ALRM2 WARNING, 122
CONC Key, 74
CONC VALID, 193
CONC_PRECISION, 74
CONC1, 51
CONC2, 51
Concentration Alarms, 96, 97
Concentration Field, 25
CONFIG INITIALIZED, 49, 178
Continuous Emission Monitoring (CEM), 67
Control Inputs
 Electrical Connections, 35
Control Inputs

Pin Assignments, 36
 Control Inputs, 54
 Control Inputs, 213
 CPU, 176, 179, 180, 182, 193, 194, 206, 212, 213, 216
 AIN Calibration, 94
 Analog to Digital Converter, 49, 78
 and Relay Board, 209
 AOUTS Calibration Values, 78
 CLOCK_ADJ, 71
 COMM Port Connections, 39
 DAS, 60, 125
 Pressure Calibration, 163
 Status LED, 182
 Watchdog LED, 183, 210
 Critical Flow Orifice, 127, 174, 179, 185, 195, 204, 205
 Current Loop Outputs, 33, 87, 88, 89
 Manual Calibration, 87

D

DAS
 disabling, 126
 DAS System, 25, 49, 51, 57, 60, 74, 125, 157, 162, 171, 178, 208, 217
 and APICOM, 144
 Channel Enabled, 127
 Channel Names, 132
 Channel setup, 129
 Channels, 126
 CALDAT, 128
 CONC, 127
 DETAIL, 128
 FAST, 128
 PNUNTC, 127
 Compact Data Report, 142
 HOLD OFF, 35, 74, 127, 141
 Number of Records, 127
 Parameters, 126, 127, 129, 133
 CONC, 131
 NXCNC1, 131
 PMTDET, 127
 Precision, 134
 Predictive Diagnostics, 128
 Report Period, 127, 138, 142
 Report Period editing, 136
 Sample Mode
 AVG, 134, 136, 138
 INST, 134, 136, 138
 MAX, 134
 MIN, 134, 136, 138
 SDEV, 134, 136, 138
 Sample Period editing, 136
 setting number of records, 139
 setup, 57
 Starting Date, 142
 Store Number of Samples, 134, 136, 138
 time stamp, 56
 Trigger, 126
 Triggering Events, 127, 129, 132
 ATIMER, 127, 131, 132
 EXITZR, 132
 SLPCHG, 128, 132
 Triggering Events, 133

DAS_HOLD_OFF, 74
 DATA INITIALIZED, 178
 Warning, 49
 DB-25M, 17, 152
 DB-9F, 17, 152
 DC Power, 36
 DCE – DTE Switch, 27
DEFAULT SETTINGS
 DAS System, 127
 Ethernet, 106
 Hessen Protocol, 118, 122
 VARS, 74
 DHCP, 50, 105
 DIAG AIO, 76
 DIAG AOUT, 76
 DIAG FCAL, 76
 DIAG I/O, 76
DIAG Menu
 password, 70
 DIAG Mode, 54
 DIAG TCHN, 76
 Diagnostic Menu (DIAG), 58, 69
 Ain Calibrated, 78, 94
 Analog I/O
 AOUT Calibration Configuration, 78, 83
 Conc_Out_1, 78
 Conc_Out_2, 78
 Conc_Out_3, 78
 Analog I/O Configuration, 76, 79, 80, 81, 82, 83, 84, 86, 88, 90, 91, 94
 Analog Output Step Test, 76
 Flow Calibration, 76
 Pressure Calibration, 76
 Signal I/O, 180
 SIGNAL I/O, 76, 182
 Test Chan Output, 76
 Test Output, 78
 diagnostic tools, 76
 Dilution Ratio (Option), 67
 Display Precision, 74
 DUAL, 62, 64, 65, 155

E

EEPROM
 Disk on Module, 136
 Electrical Connections
 AC Power, 30
 Analog Outputs, 32
 Current Loop, 87
 Voltage Ranges, 85
 Analog Outputs pin assignments, 61
 Control Inputs, 35
 Ethernet, 105
 Modem, 152
 MULTIDROP, 44
 Status Outputs, 34
 Electro-Static Discharge, 41
 ENTR Key, 58, 138
 Environmental Protection Agency(EPA), 157
 Ethernet, 104, 105
 Configuration, 105–10
 Property Defaults, 106

- using DHCP, 105
- DHCP, 50, 105
- HOSTNAME, 110
- Exhaust Gas, 28, 204
- Exhaust Gas Outlet**, 28, 47
- EXIT Key, 58
- EXITZR, 132
- External Pump, 16

F

- features, T803, 15
- Final Test and Validation Data Sheet, 51, 162
- Flash Chip, 208
- Flow Rate
 - Zero Air, 46
- FlowRate
 - Span Gas, 46
- Front Panel, 23
 - Concentration Field, 25
 - Display, 48, 76, 92
 - Keypad Definition Field, 25
 - Message Field, 25
 - Mode Field, 25
 - Status LED's, 25

G

- Gas Inlets
 - Sample, 28
 - Span**, 28
 - ZERO AIR**, 28
- Gas Outlets
 - Exhaust, 28, 47

H

- Heaters, 183, 209, 210, 211
- Hessen Protocol, 100, 114, 115, 116, 117, 118, 122
 - Activation, 115
 - and Reporting Ranges, 119
 - Default Settings, 118
 - Gas List, 120, 121
 - ID Code, 124
 - Latency Period, 115
 - response Mode, 118
 - Setup Parameters, 115
 - Status Flag
 - Default Settings, 122
 - Modes, 122
 - Unassigned Flags, 122
 - Unused Bits, 122
 - Warnings, 122
 - Status Flags, 122
 - types, 116
- Hostname, 110

I

- I²C, 182, 209
 - Status LED, 182
- I²C bus, 178, 179, 182, 189, 206, 211, 213

- Power Up Circuit, 213
- iDAS
 - configuration
 - Remote, 144
- Infrared Radiation (IR), 199, 201
- interference
 - Other Gases, 45
- Internal Pneumatics, 47
 - Basic Model 803E, 184
- Internal Pump, 48, 127, 163, 172, 173, 174, 179, 185, 186, 188, 191, 195, 203, 204, 205, 214
- Internal Pump Exhaust, 45

K

- Keypad Definition Field, 25

L

- Local Area Network (LAN), 50, 104, 105, 106, 108

M

- Machine ID, 43, 104
- magnetic field, 199, 200
- magneto-mechanical sensor, 199, 200
- Menu access
 - passwords, 69
- Menu Keys
 - CONC, 74
 - ENTR, 58, 138
 - EXIT, 58
- MENUS
 - AUTO, 66, 155
 - AUTO, auto range, 62
 - DUAL, 64, 65, 155
 - DUAL, dual range, 62
 - SNGL, 63
 - SNGL, single range, 62
- Message Field, 25
- Mode Field, 25
- modem, 39, 40, 100, 147, 152, 153, 194
- Modem, 152
 - Troubleshooting, 194
- Motherboard, 78, 87, 182
- Multidrop, 100, 104, 114

N

- National Institute of Standards and Technology (NIST)
 - Standard Reference Materials (SRM), 45, 157
 - CO₂, 157

O

- O₂, 56, 119, 155, 157, 160, 162, 163
 - paramagnetic sensor, 201
- O₂ CELL TEMP, 56, 180
- O₂ CELL TEMP WARNING, 49, 178
- O₂ CONC ALRM1 WARNING, 49
- O₂ CONC ALRM2 WARNING, 49
- O₂ M-P CAL, 54

O₂ OFFSET, 56, 180
 O₂ RANGE #1
 AUTO, 66
 O₂ RANGE #2
 AUTO, 66
 O₂ sensor, 56, 156
 zero cal, 44
 O₂ SLOPE, 56, 180
 OFFSET, 87, 91, 170, 171
 Operating Modes, 76
 Calibration Mode, 122
 Calibration Mode
 O₂ M-P CAL, 54
 SPAN CAL [type], 54
 ZERO CAL [type], 54
 DIAG Mode, 54
 Diagnostic Mode (DIAG), 76
 SAMPLE A1, 54
 Sample Mode, 25, 54, 74
 Secondary Setup, 58
 SETUP [X.X], 54
 Outlet, 47

P

paramagnetic, 15, 190, 199, 211
 paramagnetic sensor, 199, 200
 Particulate Filter, 171, 179, 205
 Password
 menu access, 69
 photocells, 200
 Pneumatic Set Up
 Basic Model 803E
 Bottled Gas, 158
 Bottled Gas, 46
 Calibration Gases, 44
 PNUMTC, 127
 Predictive Diagnostics, 147
 PRES, 56, 170, 171, 173, 180
 PTFE, 171, 172

R

RANGE, 56, 78, 119, 180
 RANGE1, 56, 119
 RANGE2, 56, 119
 RANGE2 CAL
 Remote, 36
 REAR BOARD NOT DET, 49, 122, 178
 Rear Panel
 Analog Outputs, 61
 Basic T803, 27
 Recorder Offset, 91
 Relay Board
 Troubleshooting, 190
 Relay Board Warning, 49, 179
 relay PCA, 209, 211
 Relay PCA, 210
 Status LED's, 182, 183, 210, 211
 Troubleshooting, 182, 183
 Reporting Range
 Upper Span Limit, 63
 Reporting Range, 57, 60

Configuration, 57, 60
 Modes
 SNGL, 63
 Reporting Range
 Upper Span Limit
 Dual, 65
 Reporting Range, 66
 Reporting Range
 Configuration
 AUTO, 66
 Reporting Range
 Dilution Feature (Option), 67
 Reporting Range Configuration
 DUAL, 64
 SNGL, 63
 RJ45, 17
 RS-232
 DCE – DTE, 27, 99
 RS-232, 40
 RS-232, 42
 RS-232, 99
 RS-232
 Troubleshooting, 194
 RS-232, 206
 RS-485, 100, 101, 104, 206

S

Safety Messages
 Electric Shock, 30, 209
 General, 21, 31, 44, 45, 87, 156, 175
 Qualified Personnel, 175
 Strong Oxidizer, 167, 173, 175
 SAMPLE A1, 54
 SAMPLE FL, 56, 180
 Sample Flow Sensor, 205
 Sample Flow Warning, 49, 179
 Sample Flow Warning, 122
 Sample Gas
 Venting, 46
 Sample Gas Line, 46
Sample Inlet, 28
 Sample Mode, 25, 53, 54, 74
 Sample Press Warning, 49, 179, 180
 Sample Pressure Sensor, 205
 Sensor Inputs, 191, 212
 Sample Pressure And Flow, 212
 Thermistor Interface, 212
 Serial I/O Ports
 Modem, 152
 Multidrop, 100, 104
 RS-232, 40, 127, 147
 RS-485, 100
 SETUP [X.X], 54
 Setup Mode, 53
 SLOPE, 170, 171
 SLPCHG, 128, 132
 SNGL, 62, 63
 SPAN, 36
 SPAN CAL, 170, 193
 SPAN CAL [type], 54
 Span Gas
 Concentration, 157, 160

Flow Rate, 46
 Initial Cal, 51
 Pressure Leak Check, 173
 Troubleshooting, 179, 180, 185, 186, 187
 Venting, 46
 with Alarm Options, 96
Span Inlet, 28
 Specifications, 19
 STABIL, 56, 170, 171, 180
 STABIL_GAS, 74
 Status
 CAL MODE, 35
 CO₂ Output, 35
 CONC VALID, 35
 RANGE2 CAL, 35
 SPAN CAL, 35
 SYSTEM OK, 35
 Status LED's
 I²C, 182
 Relay PCA, 182, 210, 211
 Watchdog, 182, 183, 210, 211
 Status LED's
 CO₂ Sensor, 195
 CPU, 182
 Status Outputs, 66, 213
 Electrical Connections, 34
 Pin Assignments, 35
 System
 Default Settings, 127
 SYSTEM OK, 193
 SYSTEM RESET, 179
 System Reset Warning, 49

T

Teledyne Contact Information
 Email Address, 16, **20**, 198
 Fax, 16, **20**, 198
Phone, **20**, 198
 Phone, direct, 16
 Phone, toll free, 16
 Technical Assistance, iii, 198
 Website, 16, 198
 Terminal Mode, 148
 Command Syntax, 148
 Computer mode, 100
 Interactive mode, 148
 Test Channel, 76, 78, 92
 Chassis Temp, 92
 NONE, 92
 SAMPLE FLOW, 92
 SAMPLE PRESS, 92
 Test Function
 RANGE, 78, 119
Test Functions, 55, 78, 92
 BOX TEMP, 56, 180, 188
 CO₂ CELL TEMP, 56
 CO₂ OFFSET, 56
 CO₂ SLOPE, 56
 Defined, 56
 O₂ CELL TEMP, 56, 180
 O₂ OFFSET, 56, 180
 O₂ RANGE #1

AUTO, 66
 O₂ RANGE #2
 AUTO, 66
 O₂ SLOPE, 56, 180
 OFFSET, 170, 171
 PRES, 56, 170, 171, 173, 180
 RANGE, 56, 119, 180
 RANGE1, 56, 119
 RANGE2, 56, 119
 SAMPLE FL, 56, 180
 SLOPE, 170, 171
 STABIL, 56, 170, 171, 180
 TIME, 56, 180
 TIME, 56, 180
 Touch screen Interface Electronics
 Troubleshooting, 190

V

VARS Menu, 58, 69, 73, 74, 127
 clock adjust, 71
 password, 70
VARIABLE DEFAULT VALUES, 74
 Variable Names
 CLOCK_ADJ, 74
 CONC_PRECISION, 74
 DAS_HOLD_OFF, 74
 STABIL_GAS, 74
 Ventilation Clearance, 23
 Venting, 46
 Exhaust Line, 47
 Sample Gas, 46
 Span Gas, 46
 Zero Air, 46

W

Warm-up Period, 49
 Warnings
 ANALOG CAL WARNING, 49
 BOX TEMP WARNING, 49, 178
 CANNOT DYN SPAN, 49, 122, 178
 CANNOT DYN ZERO, 49, 122, 178
 CO₂ CELL TEMP WARNING, 49
 CO₂ CONC ALRM1 WARNING, 49
 CO₂ CONC ALRM2 WARNING, 49
 CONC ALRM1 WARNING, 122
 CONC ALRM2 WARNING, 122
 CONFIG INITIALIZED, 49, 178
 DATA INITIALIZED, 49, 178
 O₂ CELL TEMP WARNING, 49, 178
 O₂ CONC ALRM1 WARNING, 49
 O₂ CONC ALRM2 WARNING, 49
 REAR BOARD NOT DET, 49, 122, 178
 RELAY BOARD WARN, 49, 179
 SAMPLE FLOW WARN, 49, 122, 179
 SAMPLE PRESS WARN, 49, 179, 180
 SYSTEM RESET, 49, 122, 179
 Warranty, 19
 Watchdog Circuit, 182
 Status LED, 182, 183, 210

Z

Zero Air, 44, 155, 156
Flow Rate, 46
Initial Cal, 51

Troubleshooting, 171, 180, 185, 186, 187
Venting, 46
ZERO AIR Inlet, 28
ZERO CAL, 170, 193
ZERO CAL [type], 54

APPENDIX A – Version Specific Software Documentation

NOTE: Appendix A-2 through Appendix A-7 include parameters for all models in the 800 Series; the footnotes in each table clarify differences among the models.

APPENDIX A-1: Models T801, 801E Menu Trees, Software Versions 1.0.3 (T-Series)/A.3 (E-Series).....	3
APPENDIX A-2: Setup Variables For Serial I/O, Software Versions 1.0.3 (T-Series)/A.3 (E-Series)	9
APPENDIX A-3: Warnings and Test Measurements, Software Versions 1.0.3 (T-Series)/A.3 (E-Series)	10
APPENDIX A-4: Signal I/O Definitions, Software Versions 1.0.3 (T-Series)/A.3 (E-Series).....	13
APPENDIX A-5: DAS Triggering Events, Parameters, Software Versions 1.0.3 (T-Series)/A.3 (E-Series)	17
APPENDIX A-6: Terminal Command Designators, Software Versions 1.0.3 (T-Series)/A.3 (E-Series)	20
APPENDIX A-7: MODBUS [®] Register Map, Software Versions 1.0.3 (T-Series)/A.3 (E-Series)	22

This page intentionally left blank.

APPENDIX A-1: Models T80X, 80XE Menu Trees, Software Versions 1.0.3 (T-Series)/A.3 (E-Series)

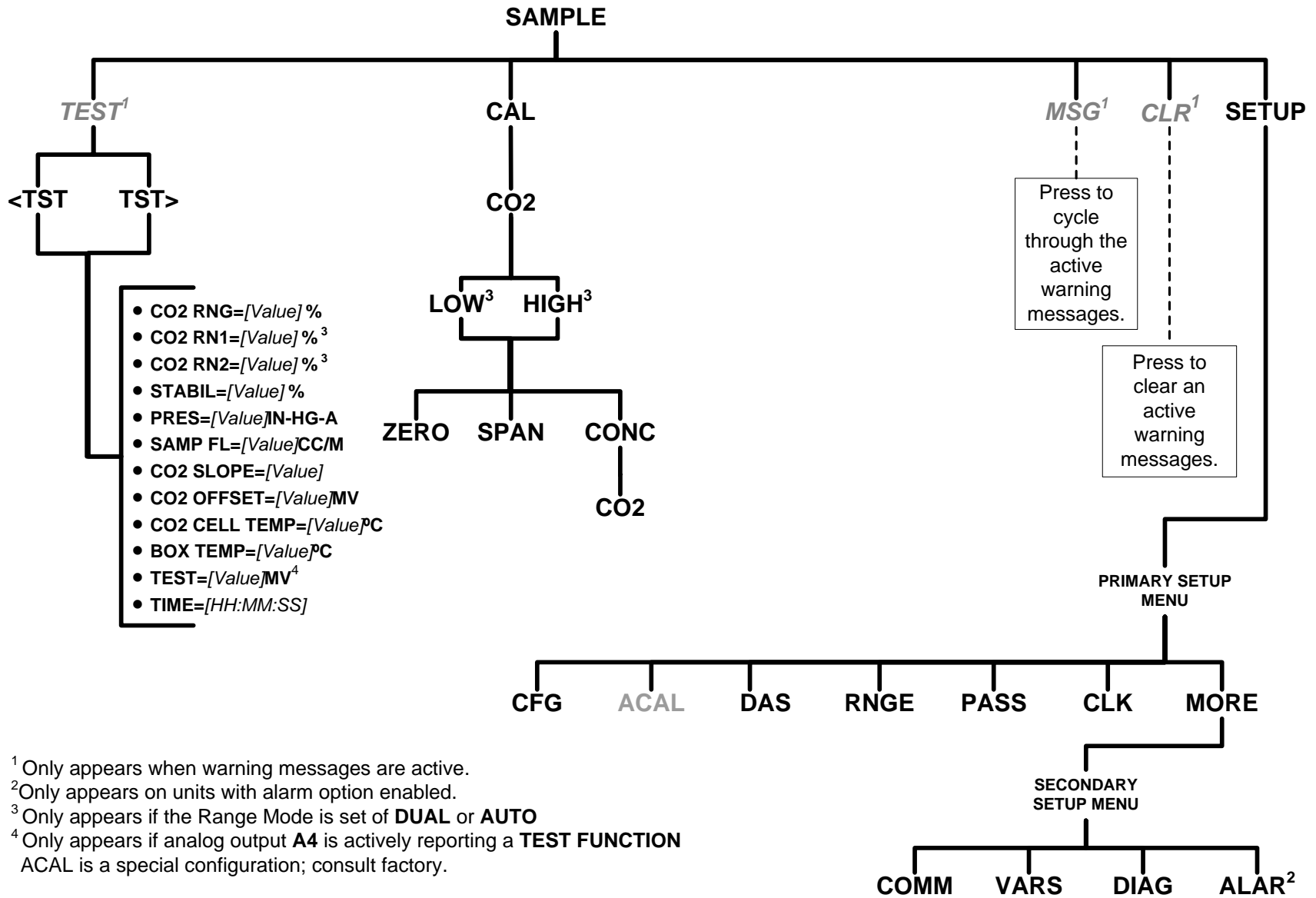

¹ Only appears when warning messages are active.
² Only appears on units with alarm option enabled.
³ Only appears if the Range Mode is set of **DUAL** or **AUTO**
⁴ Only appears if analog output **A4** is actively reporting a **TEST FUNCTION**
 ACAL is a special configuration; consult factory.

Figure A-1: Basic Sample Display Menu

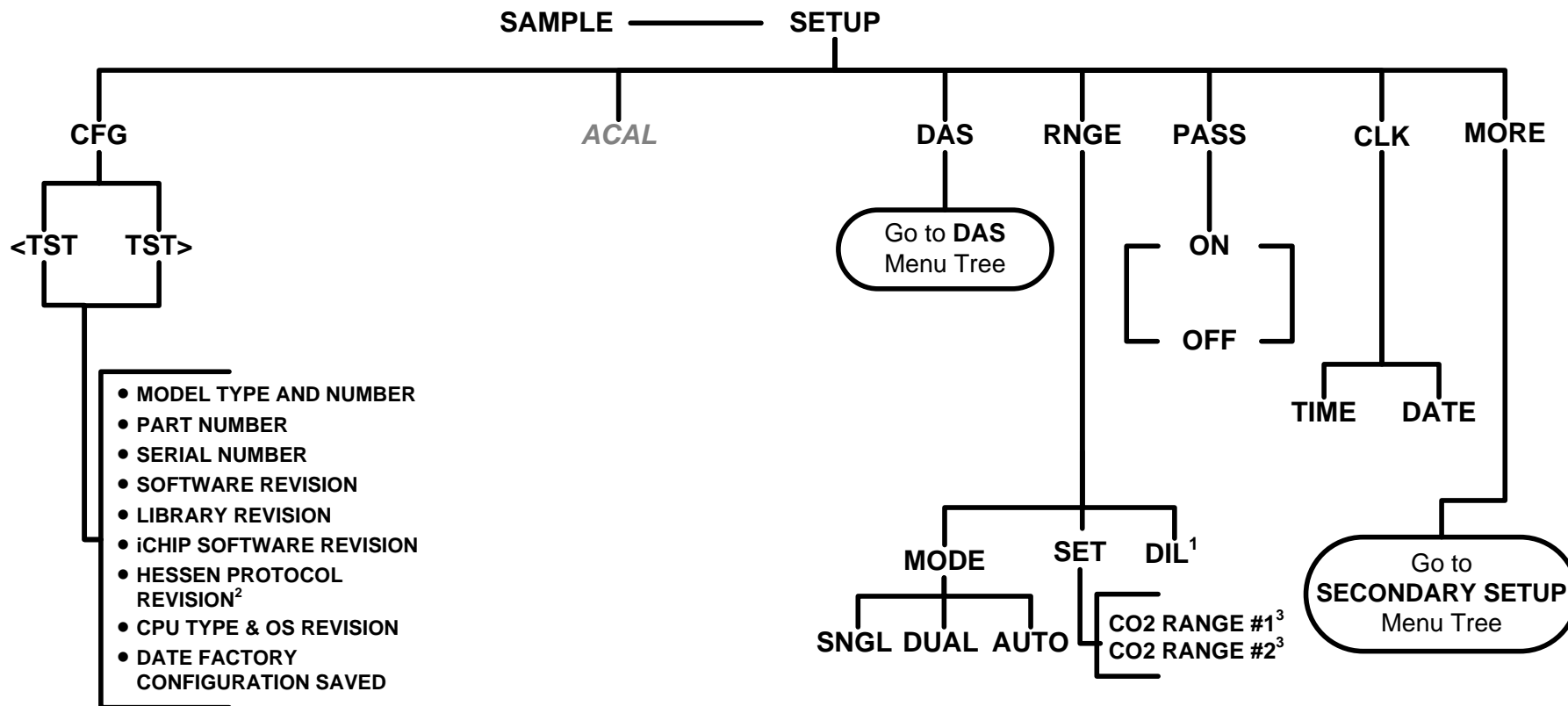

¹ Only appears if Dilution option is active.
² Only appears if Hessen protocol is active.
³ Only appears if the **DUAL** or **AUTO** range modes are selected.
 ACAL is a special configuration; consult factory.

Figure A-2: Primary Setup Menu (Except DAS)

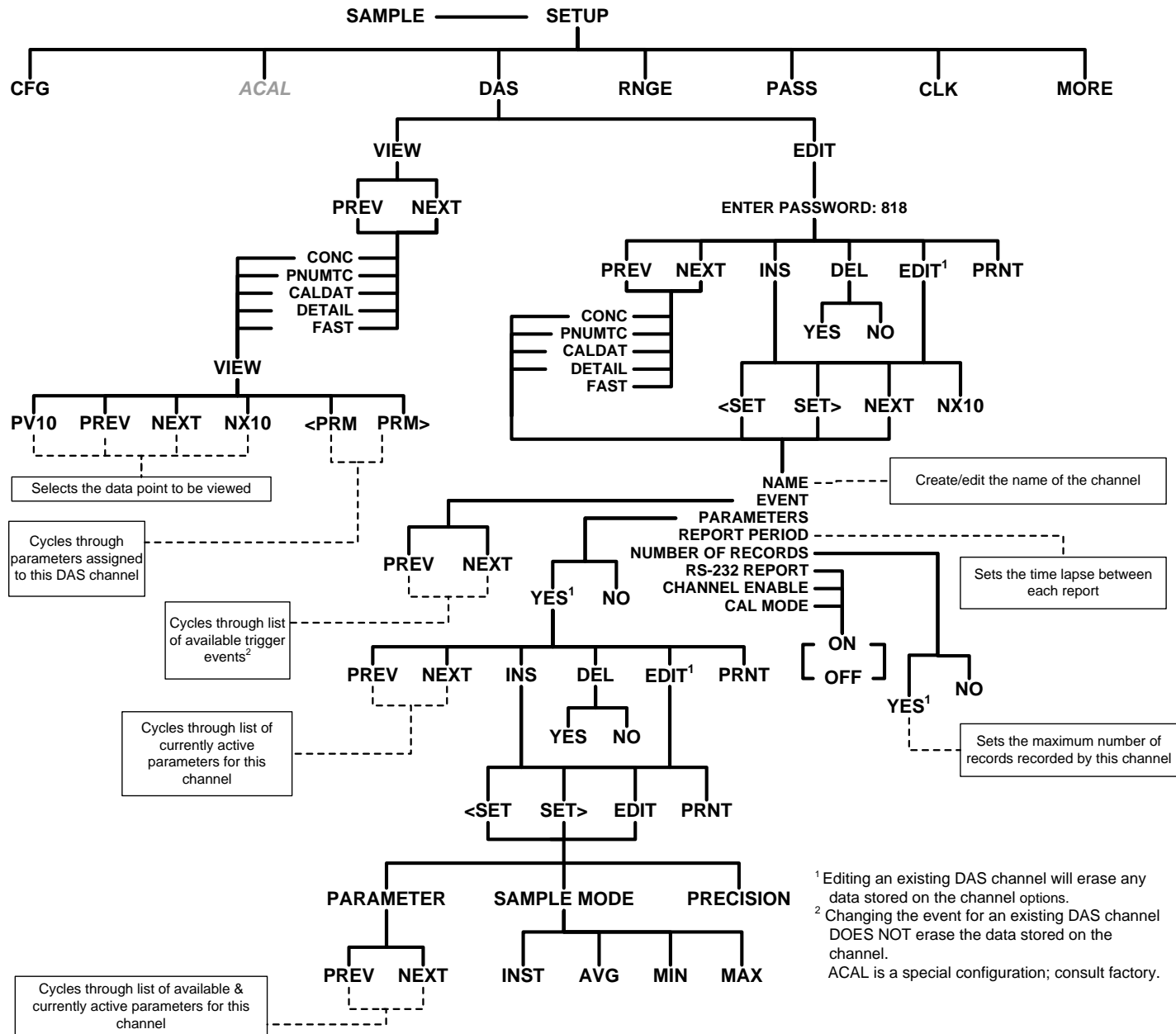

Figure A-4: Primary Setup Menu (DAS)

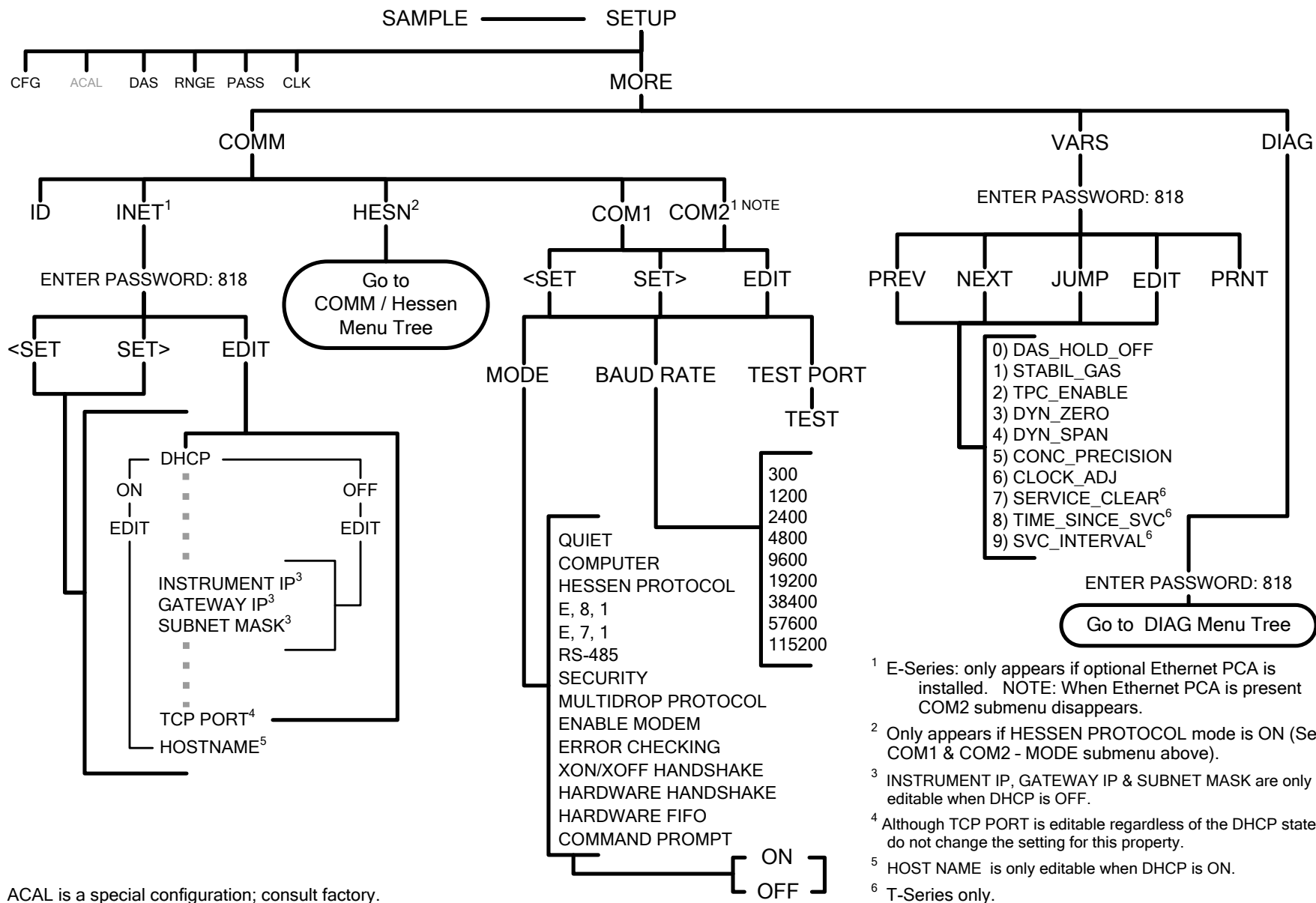

Figure A-5: Secondary Setup Menu (COMM & VARS)

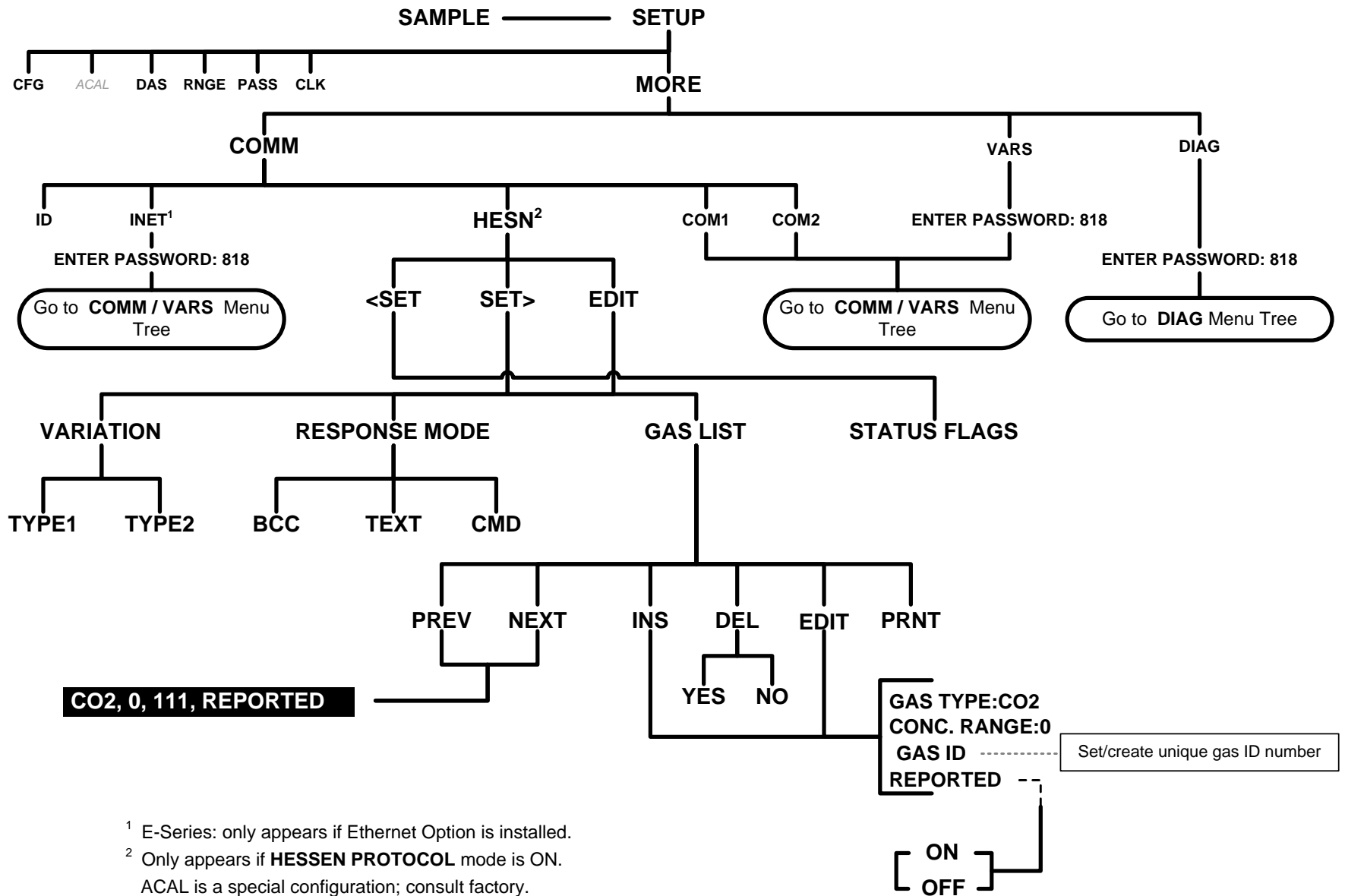

Figure A-6: Secondary Setup Menu - HESSEN Submenu

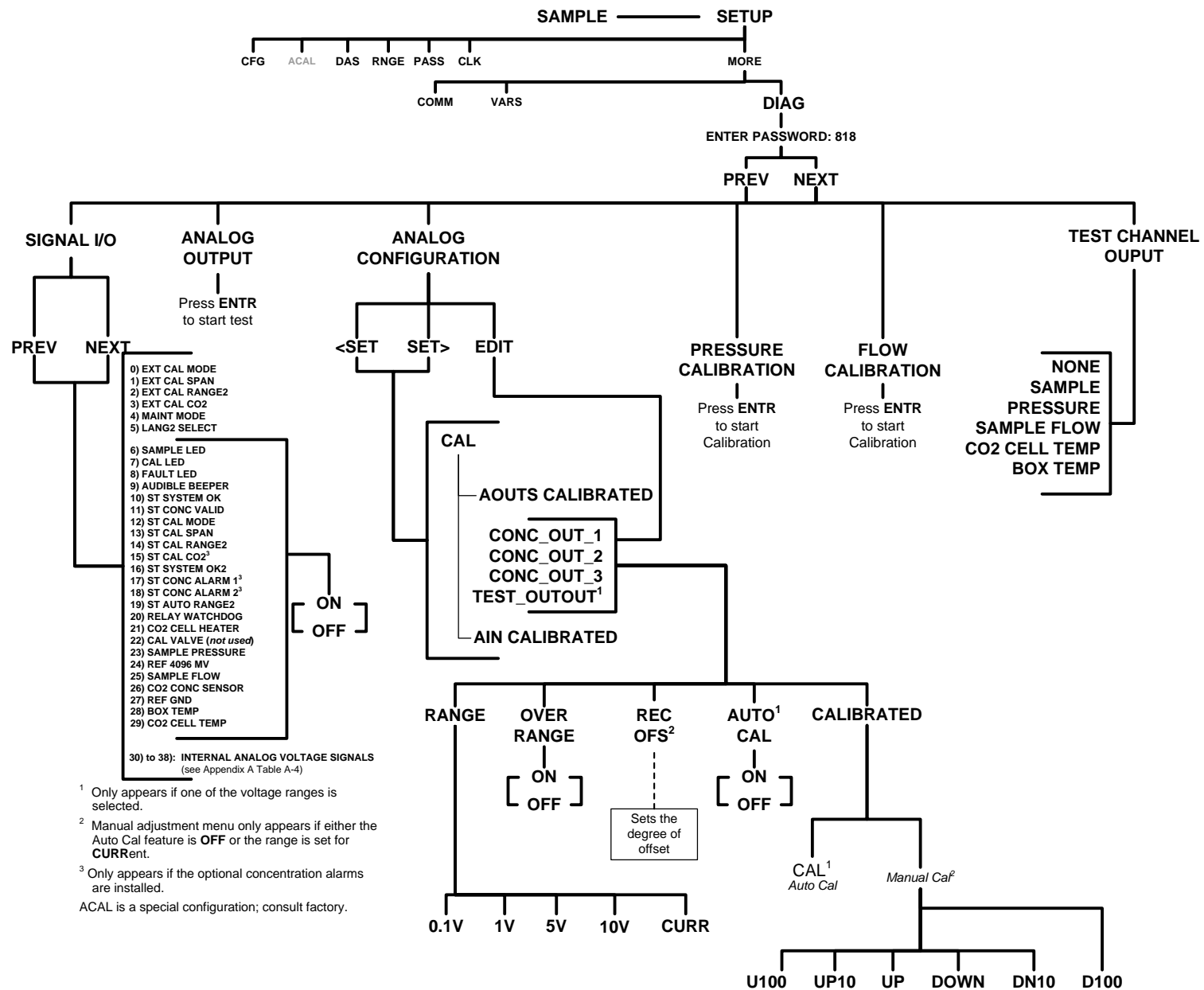

Figure A-7: Secondary Setup Menu (DIAG)

APPENDIX A-2: Setup Variables For Serial I/O, Software Versions 1.0.3 (T-Series)/A.3 (E-Series)

Table A-1: Setup Variables

Setup Variable	Numeric Units	Default Value	Value Range	Description
DAS_HOLD_OFF	Minutes	15	0.5–20	Duration of DAS hold off period.
STABIL_GAS	—	O ₂ ⁵ CO ₂ ⁴	O ₂ ³ , CO ₂ ¹	Selects gas for stability measurement. Enclose value in double quotes (") when setting from the RS-232 interface.
TPC_ENABLE	—	ON	OFF, ON	ON enables temperature and pressure compensation; OFF disables it.
DYN_ZERO	—	OFF	OFF, ON	ON enables contact closure dynamic zero; OFF disables it.
DYN_SPAN	—	OFF	OFF, ON	ON enables contact closure dynamic span; OFF disables it.
CONC_PRECISION	—	AUTO	AUTO, 0, 1, 2, 3, 4	Number of digits to display to the right of the decimal point for concentrations on the display. Enclose value in double quotes (") when setting from the RS-232 interface.
CLOCK_ADJ	Sec./Day	0	-60–60	Time-of-day clock speed adjustment.
SERVICE_CLEAR ¹⁰	—	OFF	OFF ON	ON resets the service interval timer.
TIME_SINCE_SVC ¹⁰	Hours	0	0–500000	Time since last service.
SVC_INTERVAL ¹⁰	Hours	0	0–100000	Sets the interval between service reminders.
¹ 801 , 803 or 802 with CO ₂ option. ² 802 with CO ₂ option or 803. ³ 802 or 803. ⁴ 801 or 803. ⁵ 802 only. ⁶ T Series external analog input optn. ⁷ E Series internet option. ⁸ 802 with CO ₂ option only. ⁹ 803 only. ¹⁰ T-Series only.				

APPENDIX A-3: Warnings and Test Measurements, Software Versions 1.0.3 (T-Series)/A.3 (E-Series)**Table A-2: Warning Messages**

Name ¹	Message Text	Description
Warnings		
WSYSRES	SYSTEM RESET	Instrument was power-cycled or the CPU was reset.
WDATAINIT	DATA INITIALIZED	Data storage was erased.
WCONFIGINIT	CONFIG INITIALIZED	Configuration storage was reset to factory configuration or erased.
WO2ALARM1 ³	O2 ALARM 1 WARN	O ₂ concentration alarm limit #1 exceeded
WO2ALARM2 ³	O2 ALARM 2 WARN	O ₂ concentration alarm limit #2 exceeded
WCO2ALARM1 ²	CO2 ALARM 1 WARN	CO ₂ concentration alarm limit #1 exceeded
WCO2ALARM2 ²	CO2 ALARM 2 WARN	CO ₂ concentration alarm limit #2 exceeded
WSAMPFLOW	SAMPLE FLOW WARN	Sample flow outside of warning limits.
WSAMPPRESS	SAMPLE PRESS WARN	Sample pressure outside of warning limits.
WBOXTEMP	BOX TEMP WARNING	Chassis temperature outside of warning limits.
WO2CELLTEMP ³	O2 CELL TEMP WARN	O ₂ sensor cell temperature outside of warning limits.
WCO2CELLTEMP ²	CO2 CELL TEMP WARN	CO ₂ sensor cell temperature outside of warning limits.
WDYNZERO	CANNOT DYN ZERO	Contact closure zero calibration failed while <i>DYN_ZERO</i> was set to <i>ON</i> .
WDYNSPAN	CANNOT DYN SPAN	Contact closure span calibration failed while <i>DYN_SPAN</i> was set to <i>ON</i> .
WREARBOARD	REAR BOARD NOT DET	Rear board was not detected during power up.
WRELAYBOARD	RELAY BOARD WARN	Firmware is unable to communicate with the relay board.
WFRONTPANEL	FRONT PANEL WARN	Firmware is unable to communicate with the front panel.
WANALOGCAL	ANALOG CAL WARNING	The A/D or at least one D/A channel has not been calibrated.
<p>¹ The name is used to request a message via the RS-232 interface, as in "T BOXTEMP".</p> <p>² T-Series/E-Series: 801, 803 or 802 with CO₂ option.</p> <p>³ T-Series/E-Series: 802 or 803.</p> <p>⁴ T-Series/E-Series: 801 or 803.</p> <p>⁵ T-Series/E-Series: 802 only.</p> <p>⁶ T-Series/E-Series: 803 only.</p> <p>⁷ T-Series/E-Series: 802 with CO₂ option.</p> <p>⁸ T-Series/E-Series: 801 or 802 without CO₂ option.</p> <p>¹⁰ External analog input option.</p>		

Table A-3: Test Measurements

Name ¹	Message Text	Description
Test Measurements		
O2RANGE ⁵ CO2RANGE ⁴	O2 RNG=500.0 % CO2 RNG = 500.0 %	D/A range in single or auto-range modes.
O2RANGE1 ⁵ CO2RANGE1 ⁴	O2 RN1=500.0 % CO2 RN1=500.0 %	D/A 1 range in independent range mode.
O2RANGE2 ⁵ CO2RANGE2 ⁴	O2 RN2=500.0 % CO2 RN2=500.0 %	D/A 2 range in independent range mode.
O2RANGE ⁶ CO2RANGE ⁷	O2 RNG=100 % CO2 RNG=100 %	D/A 3 range.
STABILITY	STABIL=0.0 % ⁸ O2 STB=0.0 % ² or CO2 STB=0.0 % ²	Concentration stability.
SAMPPRESS	PRES=29.9 IN-HG-A	Sample pressure.
SAMPFLOW	SAMP FL=100 CC/M	Sample flow rate.
O2SLOPE ³	O2 SLOPE=0.980	O ₂ slope, computed during zero/span calibration.
O2OFFSET ³	O2 OFST=1.79 %	O ₂ offset, computed during zero/span calibration.
CO2SLOPE ²	CO2 SLOPE=1.0000	CO ₂ slope, computed during zero/span calibration.
CO2OFFSET ²	CO2 OFST=0.00 %	CO ₂ offset, computed during zero/span calibration.
O2CELLTEMP ³	O2 CELL TEMP=50.2 C	O ₂ sensor cell temperature.
CO2CELLTEMP ²	CO2 CELL TEMP=50.2 C	CO ₂ sensor cell temperature.
BOXTEMP	BOX TEMP=35.5 C	Internal chassis temperature.
O2 ³	O2=0.00 %	O ₂ concentration.
CO2 ²	CO2=0.00 %	CO ₂ concentration.
TESTCHAN	TEST=3721.1 MV	Value output to <i>TEST_OUTPUT</i> analog output.
XIN1 ¹⁰	AIN1=37.15 EU	External analog input 1 value in engineering units.
XIN2 ¹⁰	AIN2=37.15 EU	External analog input 2 value in engineering units.
XIN3 ¹⁰	AIN3=37.15 EU	External analog input 3 value in engineering units.
XIN4 ¹⁰	AIN4=37.15 EU	External analog input 4 value in engineering units.
XIN5 ¹⁰	AIN5=37.15 EU	External analog input 5 value in engineering units.
XIN6 ¹⁰	AIN6=37.15 EU	External analog input 6 value in engineering units.
XIN7 ¹⁰	AIN7=37.15 EU	External analog input 7 value in engineering units.
XIN8 ¹⁰	AIN8=37.15 EU	External analog input 8 value in engineering units.

Name ¹	Message Text	Description
Test Measurements		
CLOCKTIME	TIME=10:38:27	Current instrument time of day clock.
<p>¹ The name is used to request a message via the RS-232 interface, as in "T BOXTEMP".</p> <p>² T-Series/E-Series: 801, 803, or 802 with CO₂ option.</p> <p>³ T-Series/E-Series: 802 or 803.</p> <p>⁴ T-Series/E-Series: 801 or 803.</p> <p>⁵ T-Series/E-Series: 802 only.</p> <p>⁶ T-Series/E-Series: 803 only.</p> <p>⁷ T-Series/E-Series: 802 with CO₂ option.</p> <p>⁸ T-Series/E-Series: 801 or 802 without CO₂ option.</p> <p>¹⁰ External analog input option.</p>		

APPENDIX A-4: Signal I/O Definitions, Software Versions 1.0.3 (T-Series)/A.3 (E-Series)

Table A-4: Signal I/O Definitions

Signal Name	Bit or Channel Number	Description
Internal inputs, U7, J108, pins 9–16 = bits 0–7, default I/O address 322 hex		
	0–7	Spare
Internal outputs, U8, J108, pins 1–8 = bits 0–7, default I/O address 322 hex		
	0–5	Spare
I2C_RESET	6	1 = reset I ² C peripherals 0 = normal
I2C_DRV_RST	7	0 = hardware reset 8584 chip 1 = normal
Control inputs, U11, J1004, pins 1–6 = bits 0–5, default I/O address 321 hex		
EXT_CAL_MODE	0	0 = go into calibration mode 1 = exit calibration mode and go into measure mode
EXT_CAL_SPAN	1	0 = calibrate span 1 = calibrate zero
EXT_CAL_RANGE2	2	0 = calibrate range #2 1 = calibrate range #1
EXT_CAL_CO2 ¹	3	0 = calibrate CO ₂ 1 = calibrate O ₂
	4–5	Spare
	6–7	Always 1
Control inputs, U14, J1006, pins 1–6 = bits 0–5, default I/O address 325 hex		
	0–5	Spare
	6–7	Always 1
Control outputs, U17, J1008, pins 1–8 = bits 0–7, default I/O address 321 hex		
	0–7	Spare
Control outputs, U21, J1008, pins 9–12 = bits 0–3, default I/O address 325 hex		
	0–3	Spare
Alarm outputs, U21, J1009, pins 1–12 = bits 4–7, default I/O address 325 hex		
ST_SYSTEM_OK2, MB_RELAY_36 ³	4	1 = system OK 0 = any alarm condition or in diagnostics mode Controlled by MODBUS coil register
ST_CONC_ALARM_1, MB_RELAY_37 ³	5	1 = conc. limit 1 exceeded 0 = conc. OK Controlled by MODBUS coil register
ST_CONC_ALARM_2, MB_RELAY_38 ³	6	1 = conc. limit 2 exceeded 0 = conc. OK Controlled by MODBUS coil register
ST_AUTO_RANGE2, MB_RELAY_39 ³	7	1 = auto-range 2 in use 0 = auto-range 1 in use Controlled by MODBUS coil register

Signal Name	Bit or Channel Number	Description
A status outputs, U24, J1017, pins 1–8 = bits 0–7, default I/O address 323 hex		
ST_SYSTEM_OK	0	0 = system OK 1 = any alarm condition
ST_CONC_VALID	1	0 = conc. valid 1 = warnings or other conditions that affect validity of concentration
ST_CAL_MODE	2	0 = in calibration mode 1 = in measure mode
ST_CAL_SPAN	3	0 = calibrating span 1 = calibrating zero
ST_CAL_RANGE2	4	0 = calibrating range 2 1 = calibrating range 1
ST_CAL_CO2 ¹	5	0 = calibrating CO ₂ 1 = calibrating O ₂
	6–7	Spare
B status outputs, U27, J1018, pins 1–8 = bits 0–7, default I/O address 324 hex		
	0–7	Spare
Front panel I²C keyboard, default I²C address 4E hex		
MAINT_MODE	5 (input)	0 = maintenance mode 1 = normal mode
LANG2_SELECT	6 (input)	0 = select second language 1 = select first language (English)
SAMPLE_LED	8 (output)	0 = sample LED on 1 = off
CAL_LED	9 (output)	0 = cal. LED on 1 = off
FAULT_LED	10 (output)	0 = fault LED on 1 = off
AUDIBLE_BEEPER	14 (output)	0 = beeper on (for diagnostic testing only) 1 = off
Relay board digital output (PCF8575), default I²C address 44 hex		
RELAY_WATCHDOG	0	Alternate between 0 and 1 at least every 5 seconds to keep relay board active
	1–3	Spare
CO2_CELL_HEATER ²	4	0 = CO ₂ sensor cell heater on 1 = off
O2_CELL_HEATER ⁴	5	0 = O ₂ sensor cell heater on 1 = off
CAL_VALVE ⁶	6	0 = let cal. gas in 1 = let sample gas in
O2_SPAN_VALVE ^{4,6}	7	0 = let O ₂ span gas in 1 = let zero gas in

Signal Name	Bit or Channel Number	Description
CO2_SPAN_VALVE ^{2,6}	8	0 = let CO ₂ span gas in 1 = let zero gas in
VENT_VALVE ⁶	9	0 = open vent valve 1 = close vent valve
	10–15	Spare
Rear board primary MUX analog inputs		
	0–3	Spare
	4	Temperature MUX
	5	Spare
O2_CONC_SENSOR ⁴	6	O ₂ concentration sensor
SAMPLE_PRESSURE	7	Sample pressure
	8	Spare
REF_4096_MV	9	4.096V reference from MAX6241
SAMPLE_FLOW	10	Sample flow rate
CO2_CONC_SENSOR ²	11	CO ₂ concentration sensor
	12–13	Spare (thermocouple input?)
	14	DAC MUX
REF_GND	15	Ground reference
Rear board temperature MUX analog inputs		
BOX_TEMP	0	Internal box temperature
	1	Spare
CO2_CELL_TEMP ²	2	CO ₂ sensor cell temperature
	3	Spare
O2_CELL_TEMP ⁴	4	O ₂ sensor cell temperature
	5–7	Spare
Rear board DAC MUX analog inputs		
DAC_CHAN_1	0	DAC channel 0 loopback
DAC_CHAN_2	1	DAC channel 1 loopback
DAC_CHAN_3	2	DAC channel 2 loopback
DAC_CHAN_4	3	DAC channel 3 loopback
Rear board analog outputs		
CONC_OUT_1, DATA_OUT_1	0	Concentration output #1, Data output #1
CONC_OUT_2, DATA_OUT_2	1	Concentration output #2, Data output #2
CONC_OUT_3 ¹ , DATA_OUT_3	2	Concentration output #3, Data output #3
TEST_OUTPUT, DATA_OUT_4	3	Test measurement output, Data output #4

Signal Name	Bit or Channel Number	Description
External analog input board, default I²C address 5C hex		
XIN1 ⁷	0	External analog input 1
XIN2 ⁷	1	External analog input 2
XIN3 ⁷	2	External analog input 3
XIN4 ⁷	3	External analog input 4
XIN5 ⁷	4	External analog input 5
XIN6 ⁷	5	External analog input 6
XIN7 ⁷	6	External analog input 7
XIN8 ⁷	7	External analog input 8
¹ T-Series/E-Series: 803 or 802 with CO ₂ option. ² T-Series/E-Series: 801 or 803. ³ MODBUS option. ⁴ T-Series/E-Series: 802 or 803. ⁵ future ⁶ Future valve option. ⁷ T-Series: External analog input option.		

APPENDIX A-5: DAS Triggering Events, Parameters, Software Version s 1.0.3 (T-Series)/A.3 (E-Series)**Table A-5: DAS Trigger Events**

Name	Description
ATIMER	Automatic timer expired
EXO2ZR ³	Exit O ₂ zero calibration mode
EXO2SP ³	Exit O ₂ span calibration mode
EXO2MP ³	Exit O ₂ multi-point calibration mode
O2SLPC ³	O ₂ slope and offset recalculated
EXCO2Z ¹	Exit CO ₂ zero calibration mode
EXCO2S ¹	Exit CO ₂ span calibration mode
EXCO2M ¹	Exit CO ₂ multi-point calibration mode
CO2SLC ¹	CO ₂ slope and offset recalculated
EXITDG	Exit diagnostic mode
CONC1W	Concentration limit 1 exceeded
CONC2W	Concentration limit 2 exceeded
O2TMPW ³	O ₂ sensor cell temperature warning
CO2TMW ¹	CO ₂ sensor cell temperature warning
SFLOWW	Sample flow warning
SPRESW	Sample pressure warning
BTEMPW	Box temperature warning
¹ T-Series/E-Series: 801, 803 or 802 with CO ₂ option.	
² future.	
³ T-Series/E-Series: 802 or 803.	

Table A-6: DAS Parameters

Name	Description	Units
O2SLP1 ²	O ₂ slope for range #1	—
O2SLP2 ⁴	O ₂ slope for range #2	—
O2OFS1 ²	O ₂ offset for range #1	%
O2OFS2 ⁴	O ₂ offset for range #2	%
CO2SL1 ¹	CO ₂ slope for range #1	—
CO2SL2 ³	CO ₂ slope for range #2	—
CO2OF1 ¹	CO ₂ offset for range #1	%
CO2OF2 ³	CO ₂ offset for range #2	%
O2ZSC1 ²	O ₂ concentration for range #1 during zero/span calibration, just before computing new slope and offset	%
O2ZSC2 ⁴	O ₂ concentration for range #2 during zero/span calibration, just before computing new slope and offset	%
CO2ZS1 ¹	CO ₂ concentration for range #1 during zero/span calibration, just before computing new slope and offset	%
CO2ZS2 ³	CO ₂ concentration for range #2 during zero/span calibration, just before computing new slope and offset	%
O2CNC1 ²	O ₂ concentration for range #1	%
O2CNC2 ⁴	O ₂ concentration for range #2	%
CO2CN1 ¹	CO ₂ concentration for range #1	%
CO2CN2 ³	CO ₂ concentration for range #2	%
STABIL	Concentration stability #1	%
O2TEMP ²	O ₂ sensor cell temperature	°C
O2DUTY ²	O ₂ sensor cell temperature controller duty cycle	Fraction (0.0 = off, 1.0 = on full)
CO2TMP ¹	CO ₂ sensor cell temperature	°C
CO2DTY ¹	CO ₂ sensor cell temperature controller duty cycle	Fraction (0.0 = off, 1.0 = on full)
SMPFLW	Sample flow	cc/m
SMPPRS	Sample pressure	"Hg
BOXTMP	Internal box temperature	°C
REFGND	Ground reference (REF_GND)	mV
RF4096	4096 mV reference (REF_4096_MV)	mV

Name	Description	Units
XIN1 ⁵	External analog input 1 value	Volts
XIN1SLPE ⁵	External analog input 1 slope	eng unit / V
XIN1OFST ⁵	External analog input 1 value	eng unit
XIN2 ⁵	External analog input 2 value	Volts
XIN2SLPE ⁵	External analog input 2 slope	eng unit / V
XIN2OFST ⁵	External analog input 2 value	eng unit
XIN3 ⁵	External analog input 3 value	Volts
XIN3SLPE ⁵	External analog input 3 slope	eng unit / V
XIN3OFST ⁵	External analog input 3 value	eng unit
XIN4 ⁵	External analog input 4 value	Volts
XIN4SLPE ⁵	External analog input 4 slope	eng unit / V
XIN4OFST ⁵	External analog input 4 value	eng unit
XIN5 ⁵	External analog input 5 value	Volts
XIN5SLPE ⁵	External analog input 5 slope	eng unit / V
XIN5OFST ⁵	External analog input 5 value	eng unit
XIN6 ⁵	External analog input 6 value	Volts
XIN6SLPE ⁵	External analog input 6 slope	eng unit / V
XIN6OFST ⁵	External analog input 6 value	eng unit
XIN7 ⁵	External analog input 7 value	Volts
XIN7SLPE ⁵	External analog input 7 slope	eng unit / V
XIN7OFST ⁵	External analog input 7 value	eng unit
XIN8 ⁵	External analog input 8 value	Volts
XIN8SLPE ⁵	External analog input 8 slope	eng unit / V
XIN8OFST ⁵	External analog input 8 value	eng unit
¹ T-Series/E-Series: 801, 803 or 802 with CO ₂ option. ² T-Series/E-Series: 802 or 803. ³ T-Series/E-Series: 801 or 803. ⁴ T-Series/E-Series: 802 only. ⁵ T-Series: External analog input option.		

APPENDIX A-6: Terminal Command Designators, Software Versions 1.0.3 (T-Series)/A.3 (E-Series)

Table A-7: Terminal Command Designators

COMMAND	ADDITIONAL COMMAND SYNTAX	DESCRIPTION
? [ID]		Display help screen and commands list
LOGON [ID]	password	Establish connection to instrument
LOGOFF [ID]		Terminate connection to instrument
T [ID]	SET ALL name hexmask	Display test(s)
	LIST [ALL name hexmask] [NAMES HEX]	Print test(s) to screen
	name	Print single test
	CLEAR ALL name hexmask	Disable test(s)
W [ID]	SET ALL name hexmask	Display warning(s)
	LIST [ALL name hexmask] [NAMES HEX]	Print warning(s)
	name	Clear single warning
	CLEAR ALL name hexmask	Clear warning(s)
C [ID]	ZERO LOWSPAN SPAN [1 2]	Enter calibration mode
	ASEQ number	Execute automatic sequence
	COMPUTE ZERO SPAN	Compute new slope/offset
	EXIT	Exit calibration mode
	ABORT	Abort calibration sequence
D [ID]	LIST	Print all I/O signals
	name[=value]	Examine or set I/O signal
	LIST NAMES	Print names of all diagnostic tests
	ENTER name	Execute diagnostic test
	EXIT	Exit diagnostic test
	RESET [DATA] [CONFIG] [exitcode]	Reset instrument
	PRINT ["name"] [SCRIPT]	Print DAS configuration
	RECORDS ["name"]	Print number of DAS records
	REPORT ["name"] [RECORDS=number] [FROM=<start date>][TO=<end date>][VERBOSE COMPACT HEX] (Print DAS records)(date format: MM/DD/YYYY(or YY) [HH:MM:SS])	Print DAS records
CANCEL	Halt printing DAS records	
V [ID]	LIST	Print setup variables
	name[=value [warn_low [warn_high]]]	Modify variable
	name="value"	Modify enumerated variable
	CONFIG	Print instrument configuration
	MAINT ON OFF	Enter/exit maintenance mode
	MODE	Print current instrument mode
	DASBEGIN [<data channel definitions>] DASEND	Upload DAS configuration
	CHANNELBEGIN propertylist CHANNELEND	Upload single DAS channel
	CHANNELDELETE ["name"]	Delete DAS channels

The command syntax follows the command type, separated by a space character. Strings in [brackets] are optional designators. The following key assignments also apply.

Table A-8: Terminal Key Assignments

TERMINAL KEY ASSIGNMENTS	
ESC	Abort line
CR (ENTER)	Execute command
Ctrl-C	Switch to computer mode
COMPUTER MODE KEY ASSIGNMENTS	
LF (line feed)	Execute command
Ctrl-T	Switch to terminal mode

APPENDIX A-7: MODBUS[®] Register Map, Software Versions 1.0.3 (T-Series)/A.3 (E-Series)

MODBUS Register Address (dec., 0-based)	Description	Units
MODBUS Floating Point Input Registers (32-bit IEEE 754 format; read in high-word, low-word order; read-only)		
0 ⁴	O ₂ slope for range 1	—
2 ⁶	O ₂ slope for range 2	—
4 ⁴	O ₂ offset for range 1	%
6 ⁶	O ₂ offset for range 2	%
8 ⁴	O ₂ concentration for range 1 during zero/span calibration, just before computing new slope and offset	%
10 ⁶	O ₂ concentration for range 2 during zero/span calibration, just before computing new slope and offset	%
12 ⁴	O ₂ concentration for range 1	%
14 ⁶	O ₂ concentration for range 2	%
16 ⁴	O ₂ sensor cell temperature	°C
18 ⁴	O ₂ sensor cell temperature control duty cycle	Fraction
20	Concentration stability	%
22	Sample flow	cc/m
24	Sample pressure	"Hg
26	Internal box temperature	°C
28	Ground reference (REF_GND)	mV
30	4096 mV reference (REF_4096_MV)	mV
100 ¹	CO ₂ slope for range 1	—
102 ⁵	CO ₂ slope for range 2	—
104 ¹	CO ₂ offset for range 1	%
106 ⁵	CO ₂ offset for range 2	%
108 ¹	CO ₂ concentration for range 1 during zero/span calibration, just before computing new slope and offset	%
110 ⁵	CO ₂ concentration for range 2 during zero/span calibration, just before computing new slope and offset	%
112 ¹	CO ₂ concentration for range 1	%
114 ⁵	CO ₂ concentration for range 2	%
116 ¹	CO ₂ sensor cell temperature	°C
118 ¹	CO ₂ sensor cell temperature control duty cycle	Fraction

MODBUS Register Address (dec., 0-based)	Description	Units
130 ⁷	External analog input 1 value	Volts
132 ⁷	External analog input 1 slope	eng unit /V
134 ⁷	External analog input 1 offset	eng unit
136 ⁷	External analog input 2 value	Volts
138 ⁷	External analog input 2 slope	eng unit /V
140 ⁷	External analog input 2 offset	eng unit
142 ⁷	External analog input 3 value	Volts
144 ⁷	External analog input 3 slope	eng unit /V
146 ⁷	External analog input 3 offset	eng unit
148 ⁷	External analog input 4 value	Volts
150 ⁷	External analog input 4 slope	eng unit /V
152 ⁷	External analog input 4 offset	eng unit
154 ⁷	External analog input 5 value	Volts
156 ⁷	External analog input 5 slope	eng unit /V
158 ⁷	External analog input 5 offset	eng unit
160 ⁷	External analog input 6 value	Volts
162 ⁷	External analog input 6 slope	eng unit /V
164 ⁷	External analog input 6 offset	eng unit
166 ⁷	External analog input 7 value	Volts
168 ⁷	External analog input 7 slope	eng unit /V
170 ⁷	External analog input 7 offset	eng unit
172 ⁷	External analog input 8 value	Volts
174 ⁷	External analog input 8 slope	eng unit /V
176 ⁷	External analog input 8 offset	eng unit
MODBUS Floating Point Holding Registers (32-bit IEEE 754 format; read/write in high-word, low-word order; read/write)		
0 ⁴	Maps to O2_TARG_SPAN1 variable; target conc. for range 1	%
2 ⁶	Maps to O2_TARG_SPAN2 variable; target conc. for range 2	%
100 ¹	Maps to CO2_TARG_SPAN1 variable; target conc. for range 1	%
102 ⁵	Maps to CO2_TARG_SPAN2 variable; target conc. for range 2	%

MODBUS Register Address (dec., 0-based)	Description	Units
MODBUS Discrete Input Registers (single-bit; read-only)		
0	Box temperature warning	
1 ⁴	O ₂ cell temperature warning	
2	Sample flow warning	
3	Sample pressure warning	
4	System reset warning	
5	Rear board communication warning	
6	Relay board communication warning	
7	Front panel communication warning	
8	Analog calibration warning	
9	Dynamic zero warning	
10	Dynamic span warning	
11	Invalid concentration	
12 ⁴	In O ₂ zero calibration mode	
13 ⁴	In O ₂ span calibration mode	
14 ⁴	In O ₂ multi-point calibration mode	
15	System is OK (same meaning as <i>SYSTEM_OK</i> I/O signal)	
16	O ₂ concentration alarm limit #1 exceeded	
17	O ₂ concentration alarm limit #2 exceeded	
18	In Hessen manual mode	
100 ¹	CO ₂ cell temperature warning	
101 ¹	In CO ₂ zero calibration mode	
102 ¹	In CO ₂ span calibration mode	
103 ¹	In CO ₂ multi-point calibration mode	
104 ¹	CO ₂ concentration alarm limit #1 exceeded	
105 ¹	CO ₂ concentration alarm limit #2 exceeded	

MODBUS Register Address (dec., 0-based)	Description	Units
MODBUS Coil Registers (single-bit; read/write)		
0	Maps to relay output signal 36 (<i>MB_RELAY_36</i> in signal I/O list)	
1	Maps to relay output signal 37 (<i>MB_RELAY_37</i> in signal I/O list)	
2	Maps to relay output signal 38 (<i>MB_RELAY_38</i> in signal I/O list)	
3	Maps to relay output signal 39 (<i>MB_RELAY_39</i> in signal I/O list)	
20 ^{3,4}	Triggers O ₂ zero calibration of range 1 (on enters cal.; off exits cal.)	
21 ^{3,4}	Triggers O ₂ span calibration of range 1 (on enters cal.; off exits cal.)	
22 ^{6,4}	Triggers O ₂ zero calibration of range 2 (on enters cal.; off exits cal.)	
23 ^{6,4}	Triggers O ₂ span calibration of range 2 (on enters cal.; off exits cal.)	
24 ^{1,3}	Triggers CO ₂ zero calibration of range 1 (on enters cal.; off exits cal.)	
25 ^{1,3}	Triggers CO ₂ span calibration of range 1 (on enters cal.; off exits cal.)	
26 ^{5,3}	Triggers CO ₂ zero calibration of range 2 (on enters cal.; off exits cal.)	
27 ^{5,3}	Triggers CO ₂ span calibration of range 2 (on enters cal.; off exits cal.)	
¹ T-Series/E-Series: 801, 803 or 802 with CO ₂ option. ² future. ³ Set <i>DYN_ZERO</i> or <i>DYN_SPAN</i> variables to <i>ON</i> to enable calculating new slope or offset. Otherwise a calibration check is performed. ⁴ T-Series/E-Series: 802 or 803. ⁵ T-Series/E-Series: 801 or 803. ⁶ T-Series/E-Series: 802 only. ⁷ T-Series: External analog input option.		

This page intentionally left blank.

APPENDIX B - Spare Parts

Note Use of replacement parts other than those supplied by Teledyne Advanced Pollution Instrumentation (TAPI) may result in non-compliance with European standard EN 61010-1.

Note Due to the dynamic nature of part numbers, please refer to the TAPI Website at <http://www.teledyne-api.com> or call Customer Service at 800-324-5190 for more recent updates to part numbers.

This page intentionally left blank.

T80X Spare Parts List

(Ref: 072690000A DCN6431, 2012 April 12)

PARTNUMBER	DESCRIPTION
000940700	CD, ORIFICE, .005 YELLOW
001763500	ASSY, FLOW CTL, 110CC, 1/4" ELBOW-B
003290000	THERMISTOR, BASIC (VENDOR ASSY)(KB)
009690200	AKIT, TFE FLTR ELEM (FL19,100=1) 47mm
009690300	AKIT, TFE FLTR ELEM (FL19, 30=1) 47mm
016290000	WINDOW, SAMPLE FILTER, 47MM (KB)
016300800	ASSY, SAMPLE FILTER, 47MM, ANG BKT, 1UM
037860000	ORING, TEFLON, RETAINING RING, 47MM (KB)
040010000	ASSY, FAN REAR PANEL (B/F)
040030100	PCA, PRESS SENSORS (1X), w/FM4
042410500	ASSY, PUMP, INT
043420000	ASSY, HEATER/THERM, O2 SEN
045230200	PCA, RELAY CARD
055100200	ASSY, OPTION, PUMP, 240V *
058021100	PCA, MOTHERBD, GEN 5-ICOP
066970000	PCA, INTRF. LCD TOUCH SCRNB, F/P
067240000	CPU, PC-104, VSX-6154E, ICOP *(KB)
067300000	PCA, AUX-I/O BD, ETHERNET, ANALOG & USB
067300100	PCA, AUX-I/O BOARD, ETHERNET
067300200	PCA, AUX-I/O BOARD, ETHERNET & USB
067900000	LCD MODULE, W/TOUCHSCREEN(KB)
068810000	PCA, LVDS TRANSMITTER BOARD
069500000	PCA, SERIAL & VIDEO INTERFACE BOARD
072150000	ASSY. TOUCHSCREEN CONTROL MODULE
072740000	MANUAL, T801, OPERATORS
072750000	MANUAL, T802, OPERATORS
072760000	MANUAL, T803, OPERATORS
073770100	DOM, w/SOFTWARE, STD, T801 *
073780100	DOM, w/SOFTWARE, STD, T802 *
073790100	DOM, w/SOFTWARE, STD, T803 *
CN0000073	POWER ENTRY, 120/60 (KB)
CN0000458	PLUG, 12, MC 1.5/12-ST-3.81 (KB)
CN0000520	PLUG, 10, MC 1.5/10-ST-3.81 (KB)
FL0000001	FILTER, SS (KB)
FM0000004	FLOWMETER (KB)
HE0000017	HTR, 12W/120V (50W/240V), CE AP (KB)
HW0000005	FOOT
HW0000020	SPRING
HW0000036	TFE TAPE, 1/4" (48 FT/ROLL)
HW0000101	ISOLATOR
HW0000453	SUPPORT, CIRCUIT BD, 3/16" ICOP
HW0000685	LATCH, MAGNETIC, FRONT PANEL
KIT000219	AKIT, 4-20MA CURRENT OUTPUT
KIT000253	ASSY & TEST, SPARE PS37
KIT000254	ASSY & TEST, SPARE PS38
OP0000030	OXYGEN TRANSDUCER, PARAMAGNETIC

T80X Spare Parts List

(Ref: 072690000A DCN6431, 2012 April 12)

OR0000001	ORING, 2-006VT *(KB)
OR0000094	ORING, 2-228V, 50 DURO VITON(KB)
PU0000022	REBUILD KIT, FOR PU20 & 04241 (KB)
RL0000015	RELAY, DPDT, (KB)
SW0000006	SWITCH, THERMAL, 60 C (KB)
SW0000025	SWITCH, POWER, CIRC BREAK, VDE/CE *(KB)
SW0000059	PRESSURE SENSOR, 0-15 PSIA, ALL SEN
WR0000008	POWER CORD, 10A(KB)

Appendix C
Warranty/Repair Questionnaire
T80X, M80XE
 (06532C DCN 5798)



TELEDYNE
 ADVANCED POLLUTION INSTRUMENTATION
 A Teledyne Technologies Company

CUSTOMER: _____ PHONE: _____

CONTACT NAME: _____ FAX NO. _____

SITE ADDRESS: _____

MODEL TYPE: _____ SERIAL NO.: _____ FIRMWARE REVISION: _____

Are there any failure messages? _____

_____ (Continue on back if necessary)

PLEASE COMPLETE THE FOLLOWING TABLE:

PARAMETER	RECORDED VALUE	ACCEPTABLE VALUE
O2 RANGE ¹	%	0-100%
O2 CELL TEMP ¹	°C	50 ± 5
O2 SLOPE ¹		1.0 ± 0.3
O2 OFFSET ¹		-10 to 10%
CO2 RANGE ¹	%	0 to 20%
CO2 CELL TEMP ¹	°C	50 ± 5
CO2 SLOPE ¹		1.0 ± 0.3
CO2 OFFSET ¹		-10 to 10%
STABIL	%	≤ 0.2% with zero air
PRESS	in-Hg-A	ambient ± 1
SAMPLE FLOW	cm ³ /min	120 ± 20
BOX TEMP	°C	ambient ± 5°C
<i>following values are under the signal i/o submenu</i>		
REF_4096_MV	mV	4096mV ±2 mV and Must be Stable
REF_GND	mV	0± 0.5 and Must be Stable

¹ Not all models are equipped with both an O₂ and a CO₂ sensor.

Cap the SAMPLE inlet and record the flow rate and pressure readings:

What is PRESS _____ in-Hg-A

What is the SAMPLE FLOW _____ cc/min

What are the failure symptoms? _____

What test have you done trying to solve the problem? _____

TELEDYNE API TECHNICAL SUPPORT
 EMAIL: sda_techsupport@teledyne.com
 PHONE: +1 (858) 657-9800 TOLL FREE: (800) 324-5190 FAX: +1 (858) 657-9816

APPENDIX D – Interconnect Wiring Diagram

This page intentionally left blank.

REVISIONS

REV	DESCRIPTION	DATE	DCN	APPROVED
01	PROTOTYPE RELEASE	2/12/11		KV
A	INITIAL RELEASE	4/2/12	6418	TN

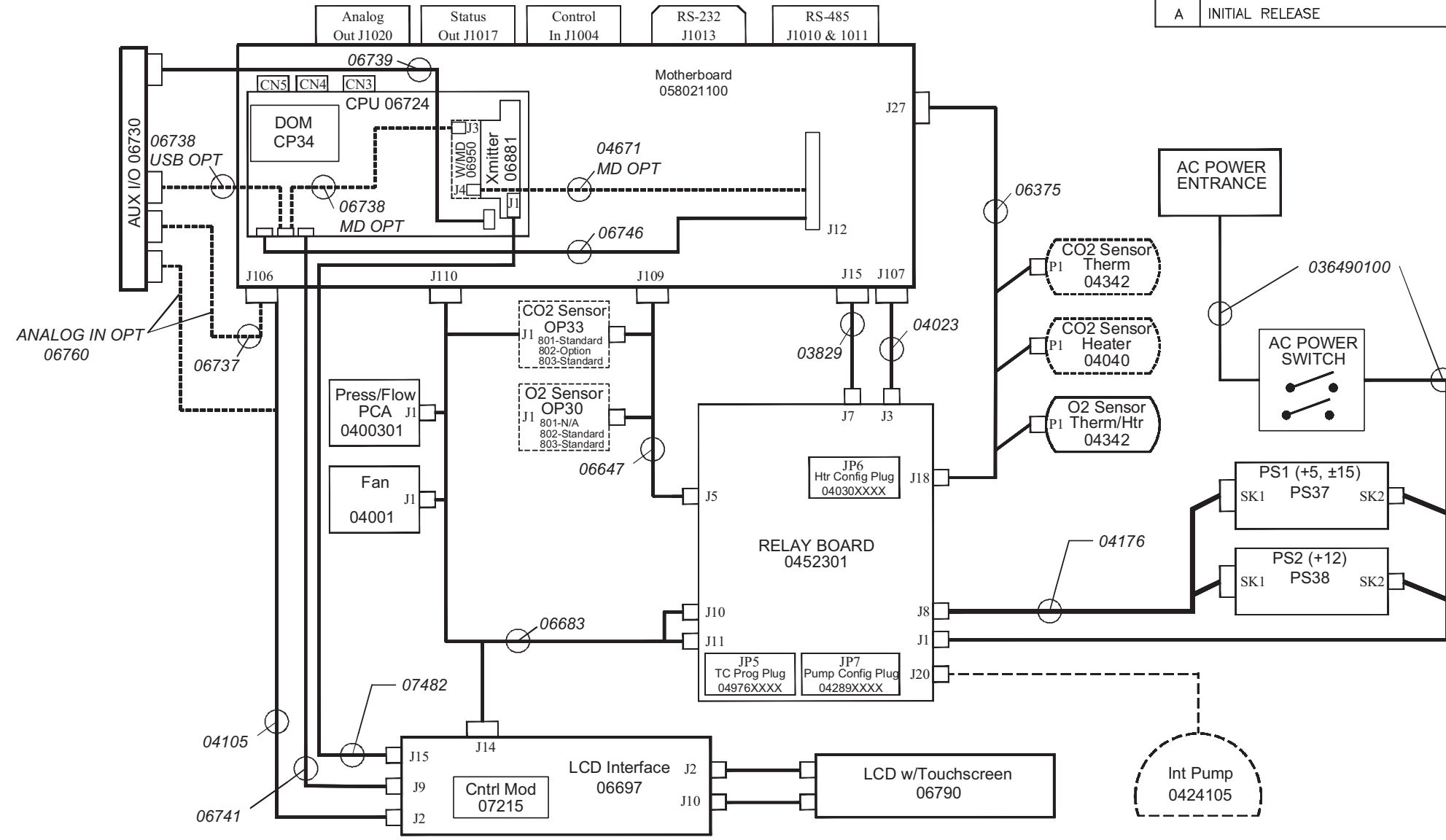

KEY:

1. All part numbers in *Italic* identify cables that are referred to in the accompanying document 073800100
2. All items in Dashed boxes are optional.

The information hereon is the property of API and is submitted in strictest confidence for reference only. Unauthorized use by anyone for any other purposes is prohibited. This document or an information contained in it may not be duplicated without proper authorization.

UNLESS OTHERWISE SPECIFIED DIMENSIONS ARE IN INCHES
 TOLERANCES ARE:
 FRACTIONS DECIMALS ANGULAR
 $\pm 1/32$ $\pm .03[0.76]$ $\pm 0^\circ 30'$
 DO NOT SCALE DRAWING

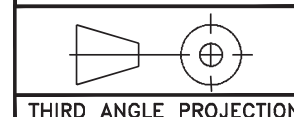

TREATMENT NA
 FINISH ∇
 SIMILAR TO

CONTRACT: NA	
APPROVALS	DATE
DRAWN KV	2/11
CHECK	
CCB	
ISSUED	

Printed Documents are Uncontrolled			
TELEDYNE Advanced Pollution Instrumentation A Teledyne Technologies Company			
TITLE		INTERCONNECT DIAGRAM T80X	
SIZE	CAGE CODE NO.	DWG. NO.	REV
B	1JZF4	07380	A
SCALE	FILE	SHEET	1 OF 1
DNS	07380		