



User Manual
Model N904
BTEX Analyzer



© Teledyne API (TAPI)
9970 Carroll Canyon Road
San Diego, California
92131-1106
USA

Toll-free Phone: +1 800-324-5190
Phone: +1 858-657-9800
Fax: +1 858-657-9816
Email: api-sales@teledyne.com
Website: <http://www.teledyne-api.com>



NOTICE OF COPYRIGHT

© 2024 Teledyne API (TAPI). All rights reserved.

TRADEMARKS

All trademarks, registered trademarks, brand names or product names appearing in this document are the property of their respective owners and are used herein for identification purposes only.

SAFETY MESSAGES

Important safety messages are provided throughout this manual for the purpose of avoiding personal injury or instrument damage. Please read these messages carefully. Each safety message is associated with a safety alert symbol and is placed throughout this manual; the safety symbols are also located inside the instrument. It is imperative that you pay close attention to these messages, the descriptions of which are as follows:



WARNING: Electrical Shock Hazard



HAZARD: Strong oxidizer



GENERAL WARNING/CAUTION: Read the accompanying message for specific information.



CAUTION: Hot Surface Warning



Do Not Touch: Touching some parts of the instrument without protection or proper tools could result in damage to the part(s) and/or the instrument.



Technician Symbol: All operations marked with this symbol are to be performed by qualified maintenance personnel only.



Electrical Ground: This symbol inside the instrument marks the central safety grounding point for the instrument.

CAUTION

This product should only be installed, commissioned, and used strictly for the purpose and in the manner described in this manual. If you improperly install, commission, or use this instrument in any manner other than as instructed in this manual or by our Technical Support team, unpredictable behavior could ensue with possible hazardous consequences.

Such risks, whether during installation and commission or caused by improper installation/commissioning/use, and their possible hazardous outcomes include but are not limited to:

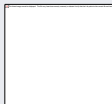

RISK	HAZARD
Liquid or dust/debris ingress	Electrical shock hazard
Improper or worn power cable	Electrical shock or fire hazard
Excessive pressure from improper gas bottle connections	Explosion and projectile hazard
Sampling combustible gas(es)	Explosion and fire hazard
Improper lift & carry techniques	Personal injury

Note that the safety of a system that may incorporate this product is the end user's responsibility.

For Technical Assistance regarding the use and maintenance of this instrument or any other Teledyne API product, contact Teledyne API's Technical Support Department:

Telephone: +1 800-324-5190
 Email: api-techsupport@teledyne.com

or access any of the service options on our website at <http://www.teledyne-api.com/>

CONSIGNES DE SÉCURITÉ

Des consignes de sécurité importantes sont fournies tout au long du présent manuel dans le but d'éviter des blessures corporelles ou d'endommager les instruments. Veuillez lire attentivement ces consignes. Chaque consigne de sécurité est représentée par un pictogramme d'alerte de sécurité; ces pictogrammes se retrouvent dans ce manuel et à l'intérieur des instruments. Les symboles correspondent aux consignes suivantes:



AVERTISSEMENT Risque de choc électrique



DANGER: Oxydant puissant



AVERTISSEMENT GÉNÉRAL / MISE EN GARDE: Lire la consigne complémentaire pour des renseignements spécifiques



MISE EN GARDE: Surface chaude



Ne pas toucher: Toucher à certaines parties de l'instrument sans protection ou sans les outils appropriés pourrait entraîner des dommages aux pièces ou à l'instrument.



Pictogramme «technicien»: Toutes les opérations portant ce symbole doivent être effectuées uniquement par du personnel de maintenance qualifié.



Mise à la terre: Ce symbole à l'intérieur de l'instrument détermine le point central de la mise à la terre sécuritaire de l'instrument.

MISE EN GARDE

Ce produit ne doit être installé, mis en service et utilisé qu'aux fins et de la manière décrites dans le présent manuel. Si vous installez, mettez en service ou utilisez cet instrument de manière incorrecte autre que celle indiquée dans ce manuel ou sous la direction de notre équipe de soutien technique, un comportement imprévisible pourrait entraîner des conséquences potentiellement dangereuses.

Ce qui suit est une liste, non exhaustive, des risques et résultats dangereux possibles associés avec une mauvaise utilisation, une mise en service incorrecte, ou causés mauvaise commission.

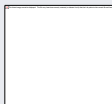

RISQUE	DANGER
Pénétration de liquide ou de poussière/débris	Risque de choc électrique
Câble d'alimentation incorrect, endommagés ou usé	Choc électrique ou risque d'incendie
Pression excessive due à des connexions de bouteilles de gaz incorrectes	Risque d'explosion et d'émission de projectile
Échantillonnage de gaz combustibles	Risque d'explosion et d'incendie
Techniques de manutention, soulevage et de transport inappropriées	Blessure corporelle

Notez que la sécurité d'un système qui peut incorporer ce produit est la responsabilité de l'utilisateur final.



WARRANTY

WARRANTY POLICY (02024J)

Teledyne API (TAPI), a business unit of Teledyne Instruments, Inc., provides that: Prior to shipment, TAPI equipment is thoroughly inspected and tested. Should equipment failure occur, TAPI assures its customers that prompt service and support will be available. (For the instrument-specific warranty period, please refer to the “Limited Warranty” section in the Terms and Conditions of Sale on our website: <http://www.teledyne-api.com>).

COVERAGE

After the warranty period and throughout the equipment lifetime, TAPI stands ready to provide on-site or in-plant service at reasonable rates similar to those of other manufacturers in the industry. All maintenance and the first level of field troubleshooting are to be performed by the customer.

NON-TAPI MANUFACTURED EQUIPMENT

Equipment provided but not manufactured by TAPI is warranted and will be repaired to the extent and according to the current terms and conditions of the respective equipment manufacturer’s warranty.

PRODUCT RETURN

All units or components returned to Teledyne API should be properly packed for handling and returned freight prepaid to the nearest designated Service Center. After the repair, the equipment will be returned, freight prepaid.

The complete Terms and Conditions of Sale can be reviewed on our website: <http://www.teledyne-api.com>.

CAUTION – Avoid Warranty Invalidation



Failure to comply with proper anti-Electro-Static Discharge (ESD) handling and packing instructions and Return Merchandise Authorization (RMA) procedures when returning parts for repair or calibration may void your warranty. For anti-ESD handling and packing instructions please refer to the manual, Fundamentals of ESD, PN 04786, in its “Packing Components for Return to Teledyne API’s Customer Service” section. The manual can be downloaded from our website at <http://www.teledyne-api.com>. RMA procedures can also be found on our website.



ABOUT THIS MANUAL

We recommend that all users read this manual in its entirety before operating the instrument.

CONVENTIONS USED

In addition to the safety symbols as presented in the *Safety Messages* page, this manual provides *special notices* related to the careful and effective use of the instrument and related, pertinent information.

ATTENTION

COULD DAMAGE INSTRUMENT AND VOID WARRANTY
This special notice provides information to avoid damage to your instrument and possibly invalidate the warranty.

Important

IMPACT ON READINGS OR DATA
Provides information about that which could either affect accuracy of instrument readings or cause loss of data.

Note

Provides information pertinent to the proper care, operation or maintenance of the instrument or its parts.



TABLE OF CONTENTS

Safety Messages	ii
Warranty	vi
Table of Contents	viii
List of Figures	x
List of Tables	xi
1. INTRODUCTION, SPECIFICATIONS, APPROVALS, & COMPLIANCE	12
1.1. Specifications	12
1.2. Compliance and Certifications	13
2. GETTING STARTED	14
2.1. Unpacking	14
2.1.1. Ventilation Clearance	15
2.2. Instrument Layout	16
2.2.1. Front Panel	16
2.2.2. Rear Panel	17
2.2.3. Internal Chassis	19
2.3. Connections and Startup	20
2.3.1. Electrical Connections	20
2.3.1.1. Connecting Power	20
2.3.1.2. Connecting Analog Outputs Option	21
2.3.1.3. Connecting the Digital I/O Expansion Board Option	22
2.3.1.4. Connecting Communications Interfaces	23
2.3.2. Pneumatic Connections	25
2.3.2.1. Critical Tubing, Pressure, Venting and Exhaust Requirements	26
2.3.2.2. Basic Pneumatic Connections	27
2.3.2.3. Basic Connections from Calibrator	27
2.3.3. Pneumatic Flow Diagrams	29
2.3.4. Startup, Functional Checks and Calibration	32
2.3.4.1. Power Status	32
2.3.4.2. Startup	33
2.3.4.3. Alerts: Warnings and Other Messages	34
2.3.4.4. Functional Checks	35
2.4. Menu Overview	36
2.4.1. Home Page	37
2.4.2. Dashboard	39
2.4.3. Alerts	40
2.4.4. Calibration	41
2.4.5. Utilities	42
2.4.6. Setup	42
2.5. Setup Menu: Features/Functions Configuration	43
2.5.1. Setup>Data Logging (Data Acquisition System, DAS)	43
2.5.1.1. Configuring Trigger Types: Periodic	45
2.5.1.2. Configuring Trigger Types: Conditional	46
2.5.1.3. Downloading DAS (Data Acquisition System) Data	46
2.5.2. Setup>Events	47
2.5.2.1. Editing or Deleting Events	49
2.5.2.2. Using Events as Triggers for Data Logging	50
2.5.3. Setup>Dashboard	50
2.5.4. Setup>AutoCal (with Valve Option)	50
2.5.5. Setup>Vars	51
2.5.6. Setup>GC Gas Config	53
2.5.7. Setup>Homescreen	55
2.5.8. Setup>Digital Outputs (Option)	56
2.5.9. Setup>Instrument	57



2.5.10. Setup>Comm (Communications)	57
2.5.10.1. COM1	57
2.5.10.2. TCP Port1	58
2.5.10.3. TCP Port2	58
2.5.10.4. Network Settings	59
2.6. Transferring Configuration to Other Instruments	60
3. COMMUNICATIONS AND REMOTE OPERATION	61
3.1. Serial Communication	61
3.1.1. MODBUS	61
3.1.2. Hessen	61
3.2. Ethernet	63
3.3. NumaView™ Remote	63
4. CALIBRATION	64
4.1. Important Precalibration Information	64
4.1.1. Calibration Requirements	64
4.1.2. Calibration (Span) Gas	65
4.1.3. Data Recording Devices	65
4.2. Calibration Procedures	65
4.2.1. Calibration and Check Procedures for Basic Configuration	66
4.2.1.1. Calibration with Blended Cylinder	66
4.2.1.2. Calibration of Individual Gas Cylinder	66
4.2.2. Calibration and Check Procedures with Span Cal Valve and Digital Expansion Board Options Installed	67
4.3. Automatic Span Cal Check (Auto Cal)	67
4.4. Linearity Calibration	68
4.4.1. Cyl Gas Config	68
4.4.2. Dilution Config	69
4.4.3. Linearize Store	70
4.4.4. View Table	71
4.5. High Concentration Applications and Calibration	72
5. MAINTENANCE AND SERVICE	73
5.1. Maintenance Schedule	73
5.2. Operational Health Checks	74
5.3. Software/Firmware Updates	75
5.3.1. Remote Updates	75
5.3.2. Manual Reload/Update Procedures	75
5.4. Time Zone Changes	77
5.5. Service and Troubleshooting	78
5.5.1. Fault Diagnosis with Alerts	79
5.5.2. Using the Diagnostic Signal I/O Functions	79
5.5.3. Fault Diagnosis with LEDs	79
5.5.4. Calibration Problems	81
5.5.4.1. Absence of Analyzer Response to Sample Gas	81
5.5.4.2. Unstable Zero and Span	81
5.5.4.3. Inability to Span - Deactivated SPAN Button	82
5.5.5. GC Status “Not Ready”	82
5.5.6. Slow Response	83
5.5.7. Subsystem Check for Troubleshooting	83
5.5.7.1. AC Main Power	84
5.5.7.2. LCD/Display Module	84
5.5.7.3. RS-232 Communications	84
5.5.8. Service Procedures	85
5.5.8.1. Filter Element Replacement	85
5.5.8.2. Column/Trap Maintenance	86
5.5.8.3. PID Sensor Lamp Maintenance or Replacement	87



5.5.8.4. PID Ion Chamber Maintenance	89
5.5.8.5. Pump Maintenance or Replacement	89
5.5.8.6. Fuse Replacement Procedure	90
5.6. Technical Assistance	91
6. PRINCIPLES OF OPERATION	92
6.1. Pneumatic Operation	93
6.2. Electronic Operation	93
6.2.1. Modules	93
6.2.2. Power Switches	94
Appendix A – MODBUS Registers	95
Appendix B – Interconnects	97

LIST OF FIGURES

Figure 2-1. Front Panel Layout	16
Figure 2-2. Rear Panel Layout	17
Figure 2-3. Internal Chassis Layout	19
Figure 2-4. Analog Outputs Connectors Panel Option	21
Figure 2-5. Digital I/O Connector Panel Option	22
Figure 2-6. Mainboard JP1 Location and Pin Arrangements	24
Figure 2-7. Gas Line Connections from Calibrator – Basic Configuration	27
Figure 2-8. Gas Line Connections without Calibrator	28
Figure 2-9. N904 Internal Pneumatic Connections	29
Figure 2-10. Pneumatic Flow for Sample and Injection Cycles with Standard Configuration	30
Figure 2-11. Pneumatic Flow for Sample and Injection Cycles with Pressurized Span Valve Option	31
Figure 2-12. Status Screens at Startup	33
Figure 2-13. Home Page	33
Figure 2-14. Viewing Active Alerts Page	34
Figure 2-15. Sample Dashboard Pages	35
Figure 2-16. User Interface Orientation	37
Figure 2-17. Accessing Concentration Graph or Meter Graph from Home page	38
Figure 2-18. Parameter Graph from Dashboard Page	39
Figure 2-19. Active Alerts Page	40
Figure 2-20. Active Alerts Cleared	41
Figure 2-21. Utilities>Alerts Log of Active and Past Alerts and Events	41
Figure 2-22. Datalog Configuration, New Log Page	43
Figure 2-23. Datalog Configuration, Existing Log	43
Figure 2-24. Creating a New Data Log	44
Figure 2-25. Datalog Periodic Trigger Configuration	45
Figure 2-26. Datalog - Conditional Trigger Configuration	46
Figure 2-27. DAS Download Page	46
Figure 2-28. Example Events List	47
Figure 2-29. Event Configuration	48
Figure 2-30. Configured Event Sample	49
Figure 2-31. Edit or Delete an Event	49
Figure 2-32. Dashboard Display and Configuration	50
Figure 2-33. GC Gas Configuration	53
Figure 2-34. Homescreen Configuration	55
Figure 2-35. Digital Outputs Setup	56
Figure 2-36. Communications Configuration, Network Settings	59
Figure 2-37. Configuration Transfer	60
Figure 4-1. Auto Cal Page	67
Figure 4-2. Linearize Menu, Cylinder Gas Configuration	69
Figure 4-3. Linearize Menu, Dilution Configuration	70
Figure 4-4. Linearize Menu, Linearize Store	70
Figure 4-5. Linearize Menu: View Table Pages for Concentrations, Areas, and Heights	71



Figure 5-1: Report Generation Page.....	74
Figure 5-2. Remote Update Page	75
Figure 5-3. Manual Update Page (and other utilities).....	75
Figure 5-4. Mainboard.....	80
Figure 5-5. PID Sensor Board.....	81
Figure 5-7. Replacing the Particulate Filter.....	86
Figure 5-6. PID Sensor Assembly, Lamp Maintenance.....	88
Figure 5-8. Fuse Access	90
Figure 6-1. Chromatograph Example of Benzene, Toluene, Ethylbenzene, M,P-Xylene, and O-Xylene Peaks	92

LIST OF TABLES

Table 1-1. Specifications.....	12
Table 2-1. Ventilation Clearance.....	15
Table 2-2. Rear Panel Description	18
Table 2-3. Analog Output Pin Assignments	21
Table 2-4. Digital Input/Output Pin Assignments	23
Table 2-5. JP1 Configurations for Serial Communication	24
Table 2-6. Menu Overview	36
Table 2-7. Utilities Submenu Descriptions	42
Table 2-8. Key Variables with Default Values and Descriptions.....	51
Table 2-9. Common Variables with Descriptions	52
Table 2-10. GC Gas Configuration Descriptions.....	54
Table 2-11. Setup>Instrument Menu	57
Table 2-12. COM1 Setup	57
Table 2-13. LAN/Ethernet Configuration Properties	59
Table 3-1. Teledyne API's Hessen Protocol Response Modes	62
Table 3-2. Hessen List Configuration Summary	63
Table 3-3. Ethernet Status Indicators	63
Table 4-1. Auto Cal Programming Sequence Execution	68
Table 5-1. Maintenance Schedule	74

1. INTRODUCTION, SPECIFICATIONS, APPROVALS, & COMPLIANCE

Teledyne API’s Model N904 BTEX Analyzer is a high-sensitivity instrument that uses Gas Chromatography (GC) with a pre-concentrator and a Photo Ionization Detector (PID) to measure Benzene, Toluene, Ethylbenzene, and (total) Xylenes (BTEX) in ambient air and provide accurate concentration readings that appear in the front panel display that can also be viewed in chromatograph format. The range and performance of the N904 are tuned specifically for use in ambient air quality monitoring assessments.

The Model N904 is designed for simple operation and maintenance with a modular hardware and electronics architecture. An internal filter is used at the sample intake to effectively remove particulate matter without introducing any gas-phase measurement artifacts. Instrument operation, calibration functions and data handling are all automated and controlled using the internal NumaView™ Software (NVS) interface without the need for an external personal computer. Additionally, NumaView™ Remote Software can also be used for remote communications, for access to the graphical user interface, for downloading data, and for other operations.

The section on Principles of Operation (Section 6) provides more information on the method and the functional details.

1.1. SPECIFICATIONS

Table 1-1. Specifications

Parameter	Description
Ranges	Min: 0-1 PPB Max: 0-200 PPB (see Section 4.5 to achieve higher range)
Lower Detectable Limit	30 PPT (Benzene); 100 PPT (TEX)
Cycle Time	< 15 minutes factory standard, (user-programmable per method used).
Precision	< 20 PPT at 1 PPB - Benzene
Linearity	< 1% of full scale
Zero Drift	Auto Zero baseline performed once each cycle
Span Drift (24 hr)	< 1% of measured value - Benzene
Sample Flow Rate	1000 cc/min ±10%
Carrier Gas	60 to 70 psig, N2 UHP Grade (99.999% purity), Consumption 15 cc/min
Auxiliary Air	70 psig ± 5%, Clean Dry Air, Consumption 1 cc/actuation
AC Power	100-240 V~, 50/60 Hz, 3 A, Typical Power Consumption 130 W
Power Entry Module Fuse	5.0 A, 250 V AC, 5 mm x 20 mm, SLO-BLO



Parameter	Description
Communications	
Standard I/O	1 Ethernet (TCP/IP) 1 RS-232 2 front panel USB device ports
Optional I/O	Universal Analog Output Board (all user-definable): 4 x isolated voltage outputs (5 V, 10 V) 3 x individually isolated current outputs (4-20 mA) Digital I/O Expansion Board includes: 3 x isolated digital input controls (fixed) 5 x isolated digital output controls (user-definable) 3 x form C relay alarm outputs (user-definable)
Operating Temperature	5-35 °C
Humidity Range	0-95% RH, Non-Condensing
Dimensions HxWxD	7" x 17" x 23.5" (178 x 432 x 597 mm)
Weight	34 lbs (15.5 kg)
Environmental Conditions	<ul style="list-style-type: none"> • Installation Category (Over Voltage Category) II Pollution Degree 2 • Intended for Indoor Use Only at Altitudes ≤ 2000m
Note: All specifications are based on constant conditions	

1.2. COMPLIANCE AND CERTIFICATIONS

The product is CE compliant and adheres to the Low Voltage and Electromagnetic Compatibility Directives.

For any other certifications, please refer to our website for the product specifications sheet.

2. GETTING STARTED

This section addresses unpacking, connecting, and initializing the instrument, getting an overview of the menu system, and setting up/configuring the functions.

2.1. UNPACKING



CAUTION - GENERAL SAFETY HAZARD

To avoid personal injury, always use two persons and proper lift and carry techniques to move/relocate the analyzer.

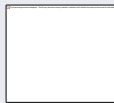

WARNING – ELECTRICAL SHOCK HAZARD

Never disconnect or reconnect PCAs, wiring harnesses or electronic subassemblies while instrument is under power.

ATTENTION

COULD DAMAGE INSTRUMENT AND VOID WARRANTY

Printed Circuit Assemblies (PCAs) are sensitive to electro-static discharges too small to be felt by the human nervous system. Failure to use Electro-Static Discharge (ESD) protection when working with electronic assemblies will void the instrument warranty. Refer to the manual, Fundamentals of ESD, PN 04786, which can be downloaded from our website at <http://www.teledyne-api.com>.

ATTENTION

COULD DAMAGE INSTRUMENT AND VOID WARRANTY

Do not operate this instrument without first removing dust plugs from SAMPLE and EXHAUST ports on the rear panel.

Note

Teledyne API recommends that you store shipping containers and materials for future use if/when the instrument should be returned to the factory for repair and/or calibration service. See Warranty statement in this manual and Return Merchandise Authorization (RMA) on our Website at <http://www.teledyne-api.com>.

Verify that there is no apparent external shipping damage. If damage has occurred, please advise the shipper first, then Teledyne API.

Included with your instrument is a printed record of the final performance characterization performed on your instrument at the factory. This record, titled Final Test and Validation Data Sheet, is an important quality assurance and calibration record and should be placed in the quality records file for this instrument.

With no power to the unit, carefully remove the top cover of the instrument and check for internal shipping damage by carrying out the following steps:

1. Carefully remove the top cover and check for internal shipping damage.
 - a. Remove the screws located on the instrument's sides.
 - b. Slide the cover backward until it clears the instrument's front bezel.
 - c. Lift the cover straight up.
2. Inspect the interior of the instrument to ensure all circuit boards and other components are intact and securely seated.
3. Check the connectors of the various internal wiring harnesses and pneumatic hoses to ensure they are firmly and securely seated.
4. Verify that all of the optional hardware ordered with the unit has been installed. These are listed on the paperwork accompanying the instrument.

2.1.1. VENTILATION CLEARANCE

Whether the instrument is set up on a bench or installed in a rack, be sure to leave sufficient ventilation clearance.

Table 2-1. Ventilation Clearance

AREA	MINIMUM REQUIRED CLEARANCE
Back of the instrument	10 cm / 4 in
Sides of the instrument	2.5 cm / 1 in
Above and below the instrument	2.5 cm / 1 in

2.2. INSTRUMENT LAYOUT

Instrument layout includes front panel, rear panel connectors, and the internal chassis layout.

2.2.1. FRONT PANEL

The front panel (Figure 2-1) includes two USB ports for peripheral device connections, which can be used with mouse and keyboard as alternatives to the touchscreen interface, or with flash drive for uploads/downloads (devices not included).

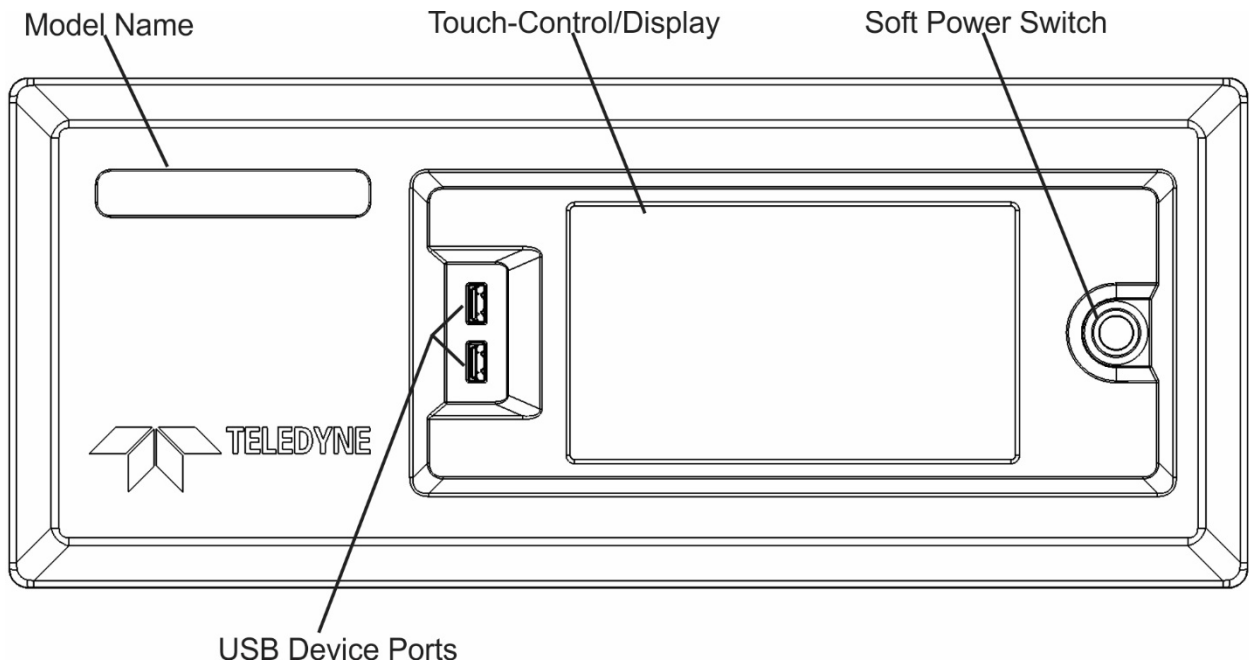

Figure 2-1. Front Panel Layout

2.2.2. REAR PANEL

Figure 2-2 shows the layout of the rear panel, and Table 2-2 provides descriptions.

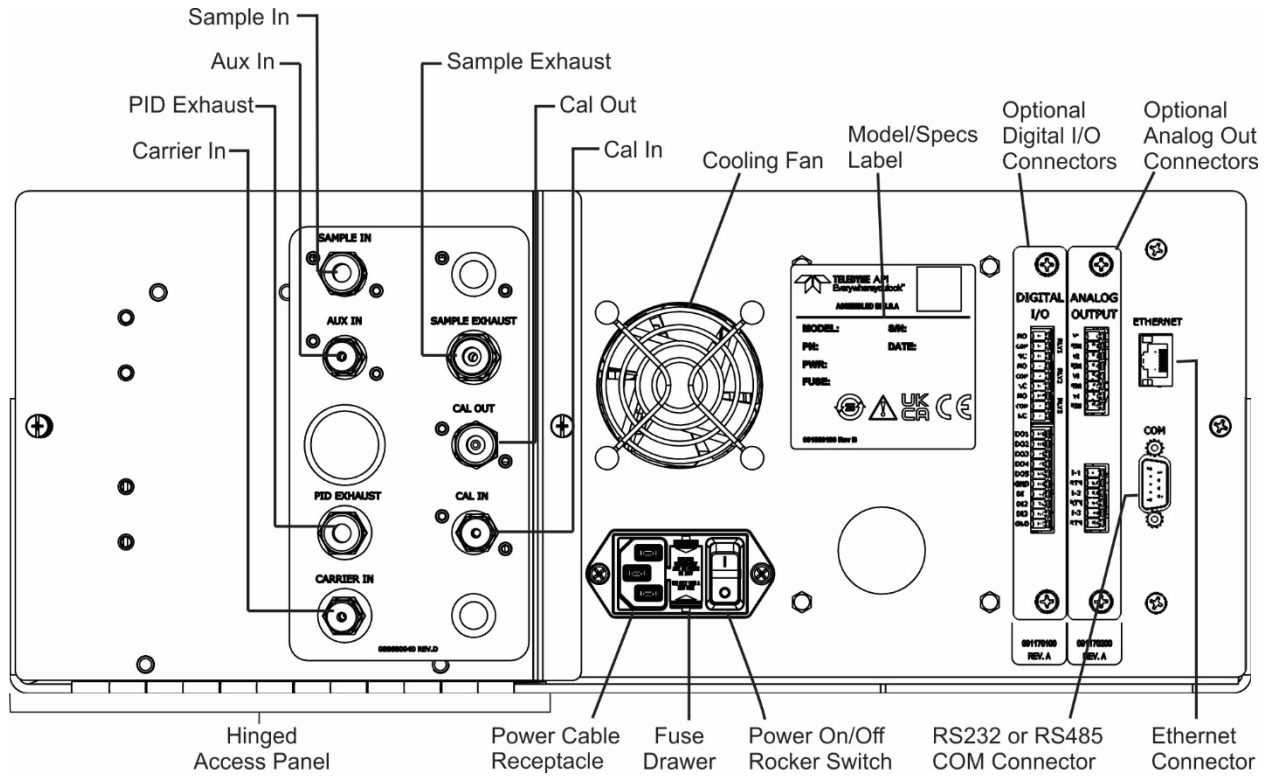



Figure 2-2. Rear Panel Layout

Table 2-2. Rear Panel Description

COMPONENT	FUNCTION
AUX IN*	Connect clean zero air or Nitrogen with pressure between 65 (MINIMUM) and 75 (MAXIMUM) PSIG to actuate the switch valve. It is possible to connect both CARRIER IN and AUX-IN ports on one line. The consumption of the Aux In is 1CC per actuation
PID EXHAUST	Keep this port clear and open in a well-ventilated area for output from the PID, which is primarily dry. If instrument is in an enclosed or poorly ventilated area, vent this port with shortest line possible with the largest inner diameter possible in order to prevent back pressure to the detector.
CARRIER IN*	Connect UHP Nitrogen (N ₂) gas (99.999% purity). The pressure supplied must be between 45-75 PSIG. The gas consumption is ~15 cc/min.
SAMPLE IN	Connect a gas line from the source of sample gas. Calibration gas can also enter here, at ambient pressure, on units without the pressurized valve option installed.
SAMPLE EXHAUST	Connect an exhaust gas line of not more than 10 meters long here that leads outside the shelter or immediate area surrounding the instrument. The line must be ¼" tubing or greater.
CAL OUT	For use in calibration when valve options installed. Connect the output to the Sample In port with Tee fitting to vent the extra gas
CAL IN	For use in calibration when valve options installed. The Calibration gas that connects to the ports should be 15PSIG ± 2PSIG
Cooling fan	Pulls ambient air into chassis through side vents and exhausts through rear (software controlled to temperature setpoint).
	Power cable connector Connector for three-prong cord to apply AC power to the analyzer. CAUTION! The cord's power specifications MUST comply with the power specs on the analyzer's rear panel label
	Power On/Off Switch Rocker switch to power unit on or off. CAUTION! Prior to powering OFF, use front panel button for "soft" power-down of internal components.
Fuse drawer	For circuit protection.
Model/specs label	Identifies the analyzer model number and provides power specs.
DIGITAL I/O Option	For remotely activating the span calibration mode.
ANALOG OUT Option	For voltage or current loop outputs to a strip chart recorder and/or a data logger.
ETHERNET	Connector for network or Internet remote communication, using Ethernet cable.
COM	Serial communications port for RS-232.

* It is possible to connect both CARRIER IN and AUX-IN ports on one line, using a tee-fitting, only if the line can supply UHP Nitrogen (N₂) gas (99.999% purity) ~70 PSIG continually (between 65-75 PSIG).

2.2.3. INTERNAL CHASSIS

Figure 2-3 shows the internal chassis layout.

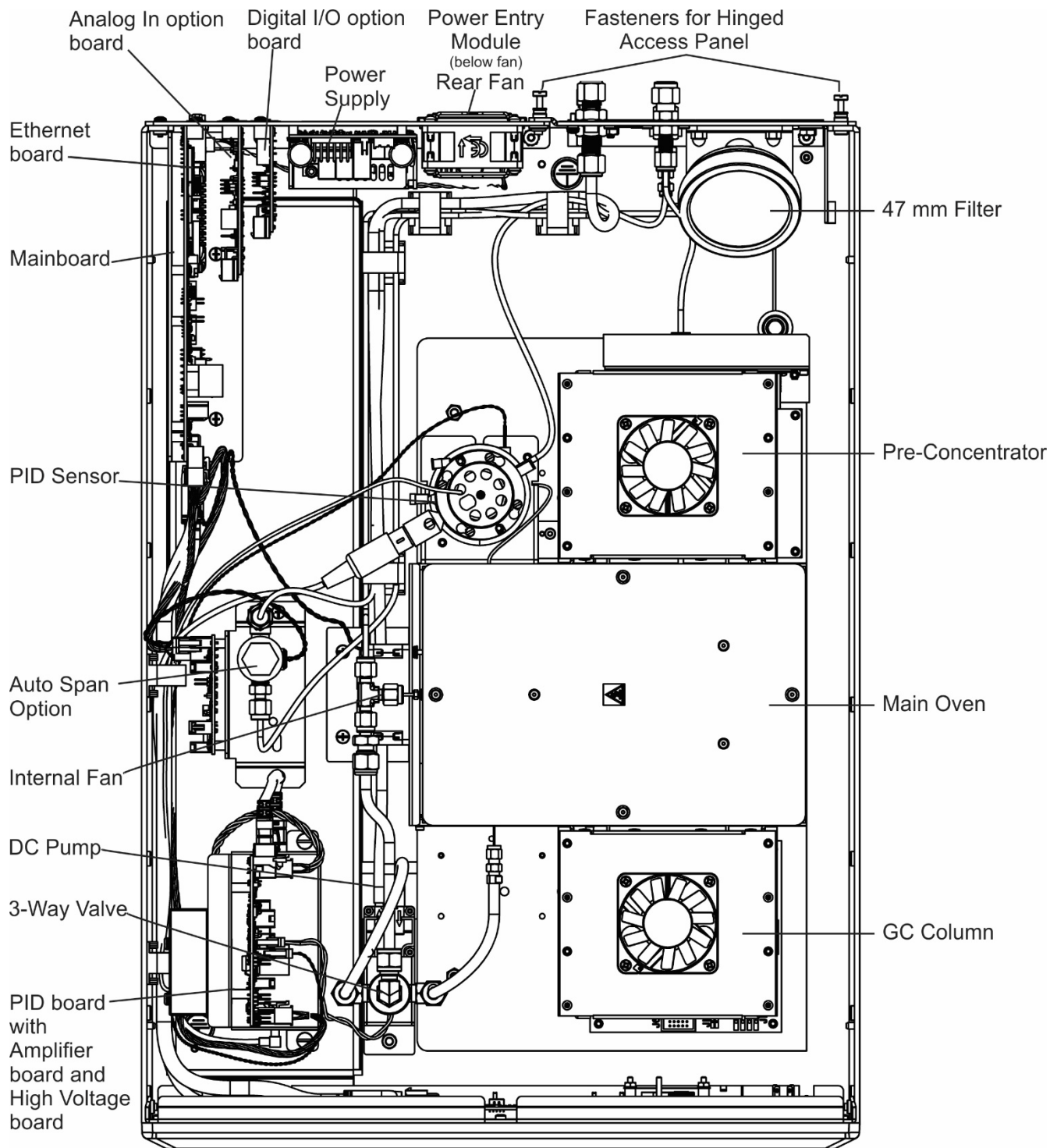

Figure 2-3. Internal Chassis Layout

2.3. CONNECTIONS AND STARTUP

This section presents the electrical (Section 2.3.1) and pneumatic (Section 2.3.2) connections for setting up and preparing the instrument for operation (Section 2.3.3).

2.3.1. ELECTRICAL CONNECTIONS

Note

To maintain compliance with EMC standards, cable length must be no greater than 3 meters for all I/O connections.



WARNING – Electrical Shock Hazard

- High Voltages are present inside the instrument's case.
- Power connection must have functioning ground connection.
- Do not defeat the ground wire on power plug.
- Turn off instrument power before disconnecting or connecting electrical subassemblies.
- Do not operate with cover off.



CAUTION – Avoid Damage to the Instrument

Ensure that the AC power voltage matches the voltage indicated on the instrument's rear panel before plugging it into line power. Always power off the instrument before changing any components.

2.3.1.1. CONNECTING POWER

Important

COULD CAUSE LOSS OR CORRUPTION OF DATA

Never power off the instrument from the rear panel Hard Power switch before using the front panel Soft Power switch, which triggers the Supervisory chip to safely run the internal computerized components shutdown process. Press and hold the front panel Soft Power switch until the instrument stops running; the LED state then changes from solid lit to blinking, at which time either the rear panel Hard Power switch can be used to finish powering off the instrument if needed, or the Soft Power switch can be pressed again later to restart the instrument.

Attach the power cord between the instrument's AC power connector and a power outlet capable of carrying at least the rated current at your AC voltage range and ensure that it is equipped with a functioning earth ground. It is important to adhere to all safety and cautionary messages.

2.3.1.2. CONNECTING ANALOG OUTPUTS OPTION

The optional rear panel Analog Output board offers several channels that can be mapped to reflect various operating values in the analyzer, including concentration values, temperatures, pressures, etc. These mappings are not configured by default and must be set by the user.

The four **voltage** outputs (0-5 V or 0-10 V) are isolated from the instrument but share a common ground. The three **current** outputs are individually isolated from each other and from the instrument.

To access these signals, attach a strip chart recorder and/or data-logger to the appropriate analog output connections, and configure through the Setup>Analog Outputs menu.

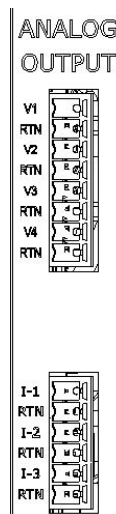

Figure 2-4. Analog Outputs Connectors Panel Option

Table 2-3. Analog Output Pin Assignments

PIN	OUTPUT	DESCRIPTION
Isolated Voltage Outputs		
V1	V +	User definable through the Setup>Analog Outputs menu.
RTN	Ground	
V2	V +	
RTN	Ground	
V3	V +	
RTN	Ground	
V4	V +	
RTN	Ground	
Isolated Current Outputs		
I-1	I Out +	User definable through the Setup>Analog Outputs menu.
RTN	I Out -	
I-2	I Out +	
RTN	I Out -	
I-3	I Out +	
RTN	I Out -	

2.3.1.3. CONNECTING THE DIGITAL I/O EXPANSION BOARD OPTION

The connections on this board include three relay alarms, five digital outputs, and three isolated digital input controls. The **Relays** can be mapped to reflect various internal instrument conditions and states. The **Outputs** are isolated from the instrument and consist of open collector transistors with a common ground; they can be mapped to reflect various internal instrument conditions and states; they can be used to interface with devices that accept logic-level digital inputs, such as Programmable Logic Controllers (PLCs). The **Inputs** are also isolated but share the same ground as the Outputs; they will work with relays, open collectors, or 3.3 V – 24 V logic. Pull low to activate. DI1 and DI2 are fixed (not mappable) for remote zero and span calibrations.

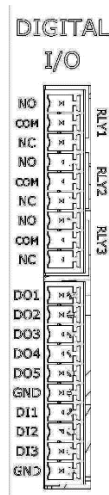

Figure 2-5. Digital I/O Connector Panel Option

Table 2-4. Digital Input/Output Pin Assignments

PIN	DESCRIPTION	
Relays		
NO	RLY 1	Relay Alarms, user-configurable through the Setup>Digital Outputs menu.
COM		
NC		
NO	RLY 2	
COM		
NC		
NO	RLY 3	
COM		
NC		
Digital Outputs and Inputs		
DO1	Digital Outputs mappable in the Setup>Digital Outputs menu, and viewable in the Utilities>Diagnostics>Digital Outputs menu	
DO2		
DO3		
DO4		
DO5		
GND	Ground	
DI1	Digital Input1 = Remote Zero Cal	
DI2	Digital Input2 = Remote Span Cal	
DI3	(Digital Input3 not used)	
DI3	View status in Utilities>Diagnostics>Digital Inputs menu	
GND	Ground	

2.3.1.4. CONNECTING COMMUNICATIONS INTERFACES

ETHERNET CONNECTION

For network or Internet communication with the analyzer, connect an Ethernet cable from the analyzer’s rear panel Ethernet interface connector to an Ethernet port. Although the analyzer is shipped with DHCP enabled by default, it should be manually configured with a static IP address.

SERIAL CONNECTION

Received from the factory, the analyzer COM port is set up for RS-232 communications with data communication equipment (DCE). This port can be reconfigured for RS-232 communications with data terminal equipment (DTE) by jumpering the pins on JP1 as indicated in Table 2-5 (view/edit software settings Table 2-12).



WARNING – ELECTRICAL SHOCK HAZARD

Disconnect all power before performing any operation that requires entry into the interior of the analyzer.

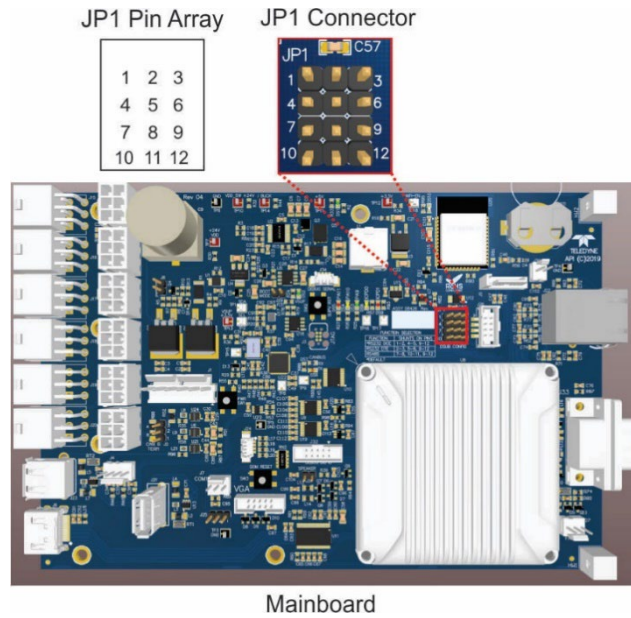

Figure 2-6. Mainboard JP1 Location and Pin Arrangements

Table 2-5. JP1 Configurations for Serial Communication

Function	Jumpers	DSub Pins	
		2	3
DCE RS232 (default)	1-2, 4-5, 9-12	232Tx	232Rx
DTE RS232	2-3, 5-6, 9-12	232Rx	232Tx

View/edit the Communications parameters in the Setup>Comm>COM1 menu.

RS-232

- **Baud rate:** 115200 bits per second (baud)
- **Data Bits:** 8 data bits with 1 stop bit
- **Parity:** None

2.3.2. PNEUMATIC CONNECTIONS

This section provides pneumatic connection and setup instructions for basic configuration. Pneumatic flow diagrams are shown in Section 2.3.3. Calibration instructions are provided in Section 4.

Before making the pneumatic connections, carefully note the following cautionary and special messages:



CAUTION – General Safety Hazard

Do not vent calibration gas or sample exhaust gas into enclosed areas.



CAUTION – General Safety Hazard

Consult with Technical Support on additional safety issues.

ATTENTION

COULD DAMAGE INSTRUMENT AND VOID WARRANTY

VENT PRESSURIZED GAS:

When any gas (span, zero air, sample) is received from a pressurized manifold, always provide a vent to equalize the pressure with the ambient atmosphere before it enters the instrument to ensure that the gases input do not exceed the instrument's maximum inlet pressure, as well as to prevent back diffusion and pressure effects.

PREVENT BACKPRESSURE IN PID EXHAUST

If tubing is required, ensure it is the shortest line possible and the largest inner diameter possible.

REMOVE DUST PLUGS:

Remove dust plugs from rear panel Sample and FID exhaust ports and supply line fittings before powering on the instrument.

Keep dust plugs for reuse in future storage or shipping to prevent debris from entering the pneumatics.

Important

IMPACT ON READINGS OR DATA



- **AUX IN** requires **MINIMUM 65 psig**.
- **Sample and calibration gases should only come into contact with PTFE, Stainless-Steel, or other inert tubing.**
- **Do NOT place any mufflers or filters downstream of the pump, i.e., external to the instrument.**
- **Run a leak check once the appropriate pneumatic connections have been made; check all pneumatic fittings for leaks per Section 5.4.12.1 (or Section 5.4.12.2 for detailed check if any leaking is suspected).**

2.3.2.1. CRITICAL TUBING, PRESSURE, VENTING AND EXHAUST REQUIREMENTS

The requirements presented in this section apply to all pneumatic connection instructions.

Tubing:

- Outer diameter (OD) minimums and material:
 - 1/4" OD for Sample, and Sample Exhaust, and PID Exhaust PTFE or Stainless Steel
 - 1/8" OD for Carrier, and Auxiliary gases, Stainless Steel only
- Min/max length 2 meters to 10 meters
- Refer to Table 2-2 for PID EXHAUST requirements.

Pressure:

- All Sample gas pressure must be at ambient atmospheric pressure, no greater or less than 1.0 psig.

Venting (to prevent back diffusion and pressure effects):

- Run tubing outside the enclosure or at least away from immediate area surrounding the instrument.
- Refer to Table 2-2 for PID EXHAUST requirements.

Sample Exhaust Outlet:

- Run tubing outside the enclosure.

PID Exhaust Outlet:

- Refer to Table 2-2

Calibration Gas Sources:

- The source of calibration gas or zero air is also attached to the **SAMPLE** inlet, but only when a calibration operation is actually being performed.

2.3.2.2. BASIC PNEUMATIC CONNECTIONS

Please refer to Table 2-2 for additional notes regarding these connections.

Ensure to prevent backflow.

- AUX IN*** Connect clean zero air or Nitrogen at 70 PSIG to actuate the switch valve. The consumption of the Aux In is 1cc per actuation
*It is possible to connect both CARRIER IN and AUX-IN ports on one line with 70 psig nitrogen gas. The consumption of the Aux In is 1cc per actuation.
- PID EXHAUST** Keep this port clear and open in a well-ventilated area. If instrument is in an enclosed or poorly ventilated area, vent this port with shortest line possible with the largest inner diameter possible in order to prevent back pressure to the detector.
- CARRIER IN** Connect UHP Nitrogen (N₂) gas (99.999%), pressurized at 50 PSIG.
- SAMPLE IN** Connect a gas line from the source of sample gas here.
- SAMPLE EXHAUST** Connect an exhaust gas line of ¼" tubing not more than 10 meters long here that leads outside the shelter or immediate area surrounding the instrument.

2.3.2.3. BASIC CONNECTIONS FROM CALIBRATOR

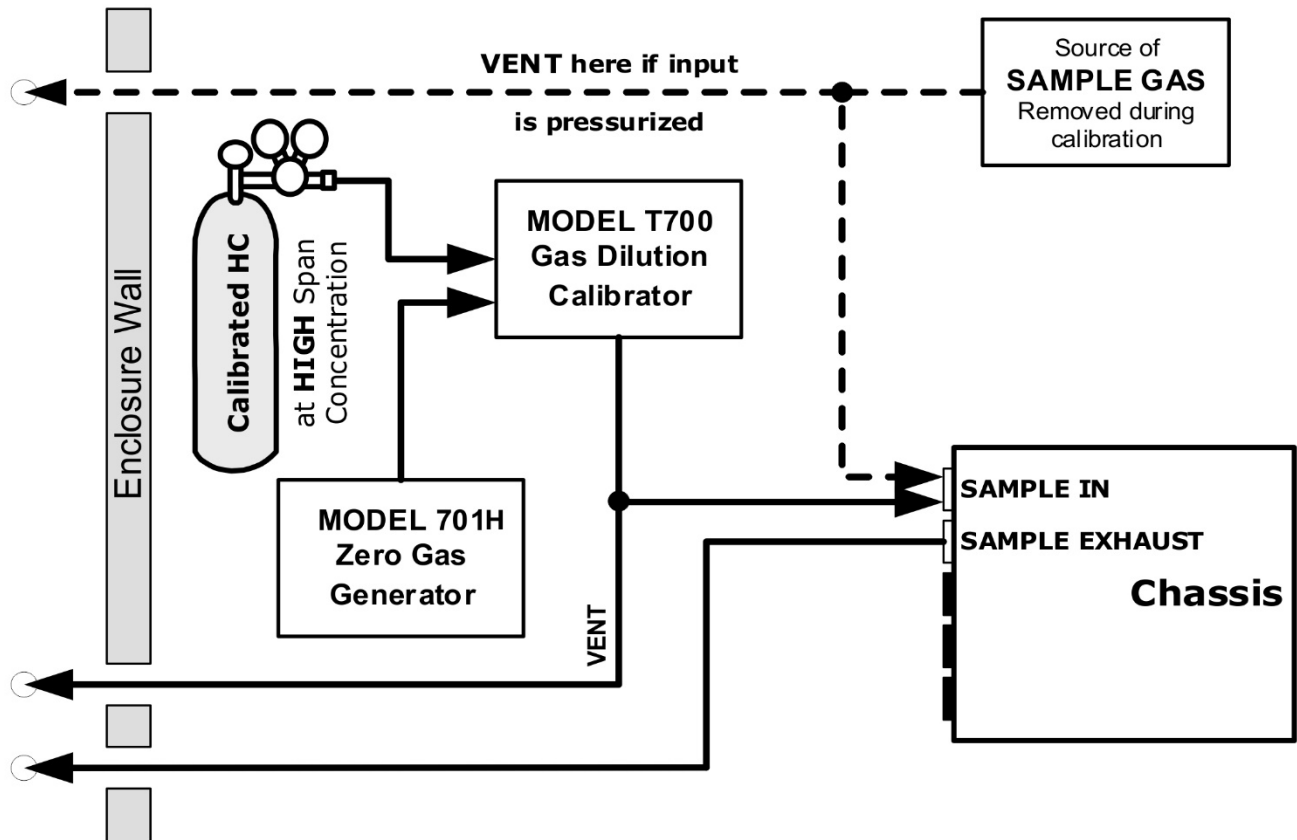

Figure 2-7. Gas Line Connections from Calibrator – Basic Configuration

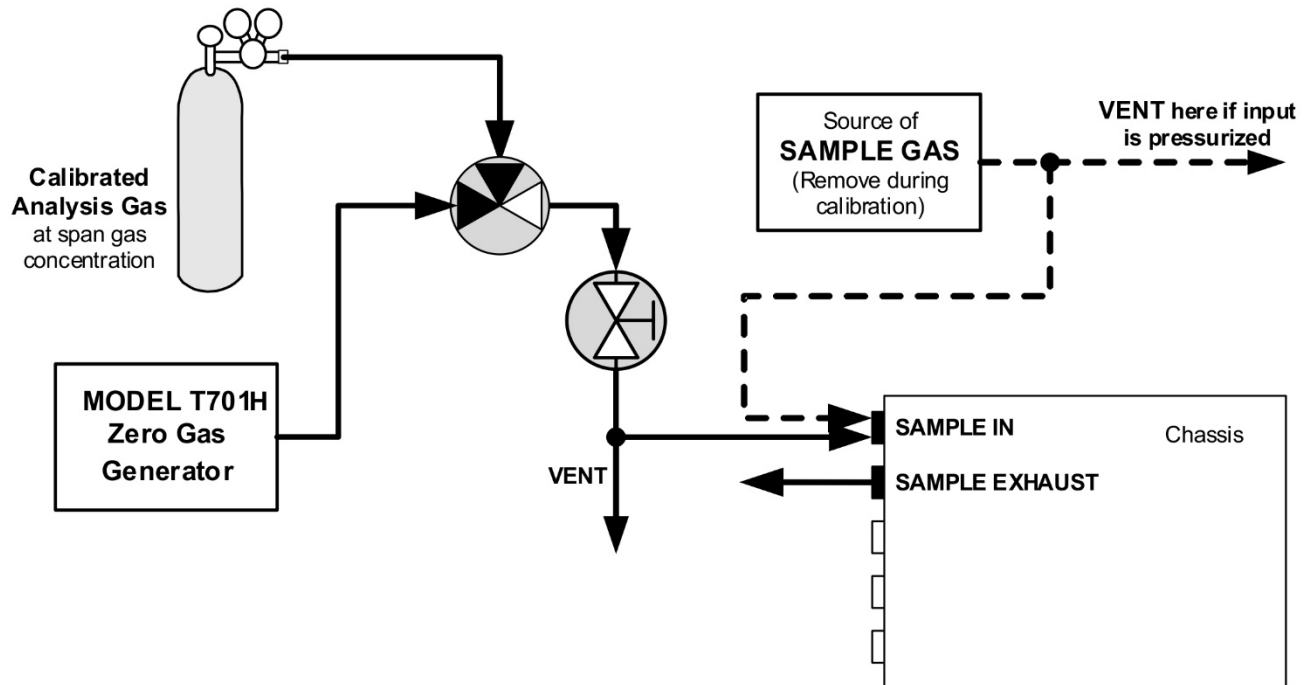

Figure 2-8. Gas Line Connections without Calibrator

For the analyzer's basic configuration, in addition to tubing, pressure, venting, and exhaust requirements set out in Section 2.3.2.1, attach the following pneumatic lines:

SAMPLE GAS SOURCE

Connect a sample gas line to the SAMPLE IN port.

CALIBRATION GAS SOURCES

SPAN CAL GAS & ZERO AIR SOURCES: The source of calibration gas and zero gas are routed through the T700 and attached to the SAMPLE IN port.

VENTING

Vent the output of the calibrator if calibrator not already vented.

EXHAUST OUTLET

Attach an exhaust line to the SAMPLE EXHAUST outlet fitting and vent outside the shelter.

2.3.3. PNEUMATIC FLOW DIAGRAMS

Figure 2-9 shows the N904's internal pneumatic connections. Figure 2-10 shows the pneumatic sample and injection flows in the standard configuration, and Figure 2-11 shows the pneumatic sample and injection flows with the pressurized span valve option.

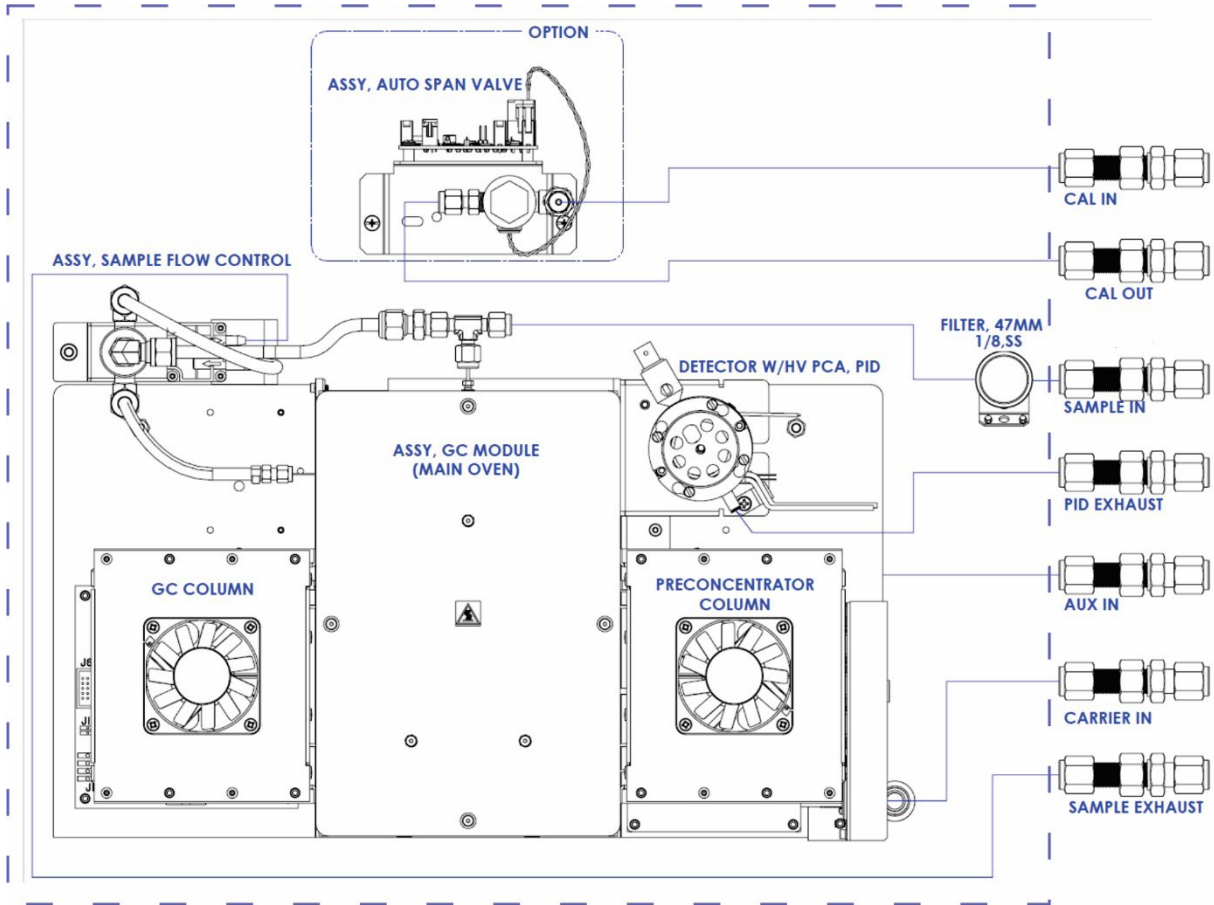
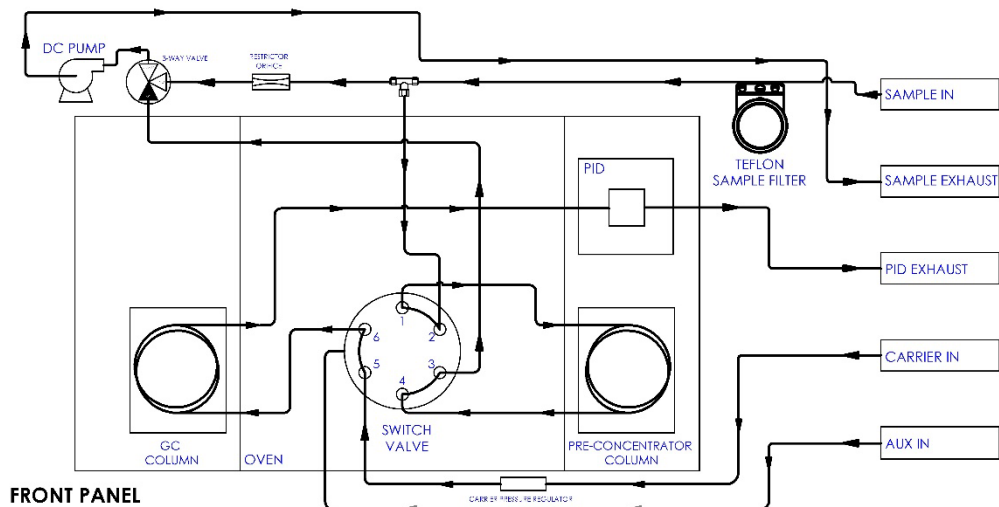

Figure 2-9. N904 Internal Pneumatic Connections

SAMPLING CYCLE

FILLING THE PRE-CONCENTRATOR WITH SAMPLE



INJECTION CYCLE

RELEASING THE SAMPLE FROM THE PRE-CONCENTRATOR AND INJECTING IT TO THE GC COLUMN

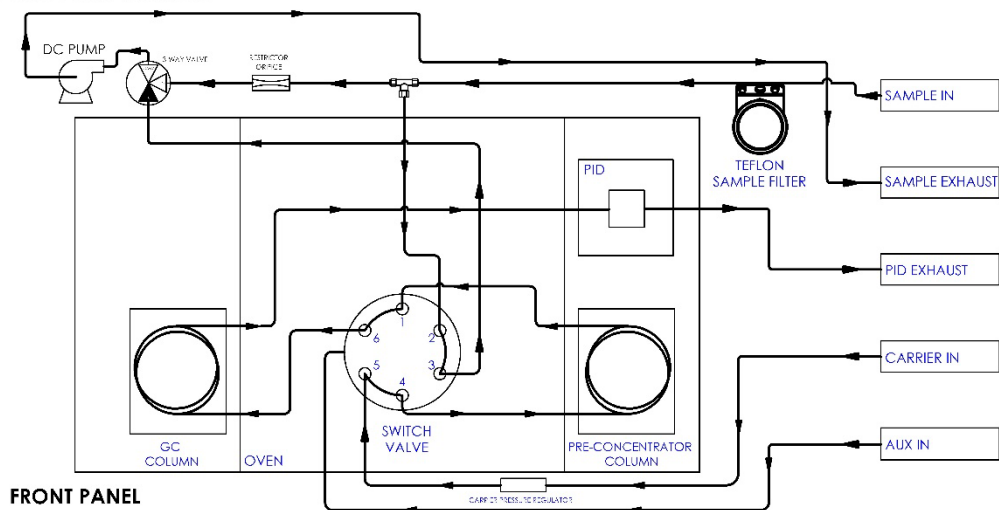
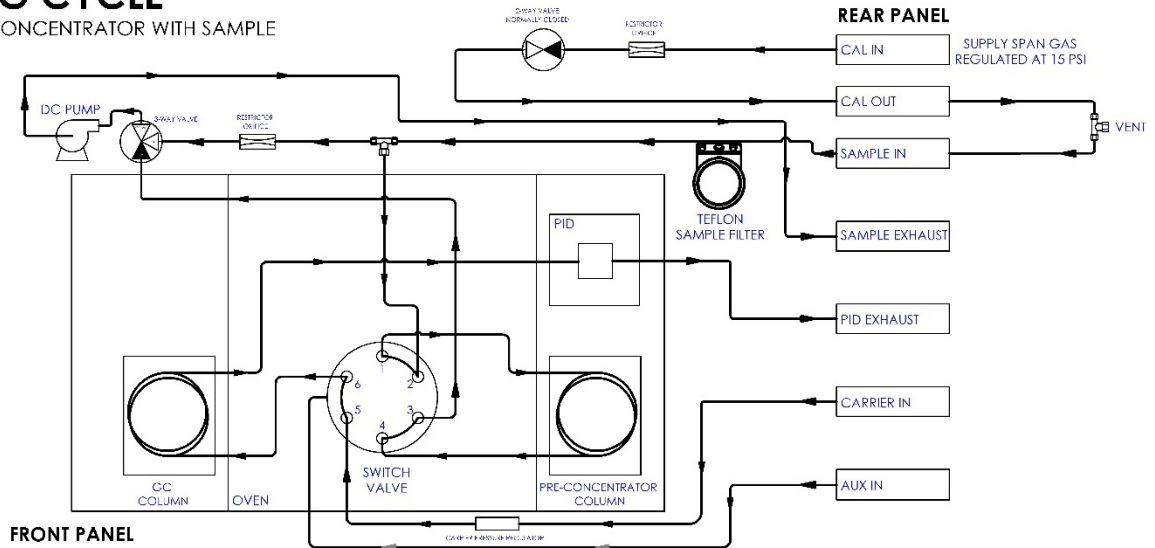

Figure 2-10. Pneumatic Flow for Sample and Injection Cycles with Standard Configuration

SAMPLING CYCLE

FILLING THE PRE-CONCENTRATOR WITH SAMPLE



INJECTION CYCLE

RELEASING THE SAMPLE FROM THE PRE-CONCENTRATOR AND INJECTING IT TO THE GC COLUMN

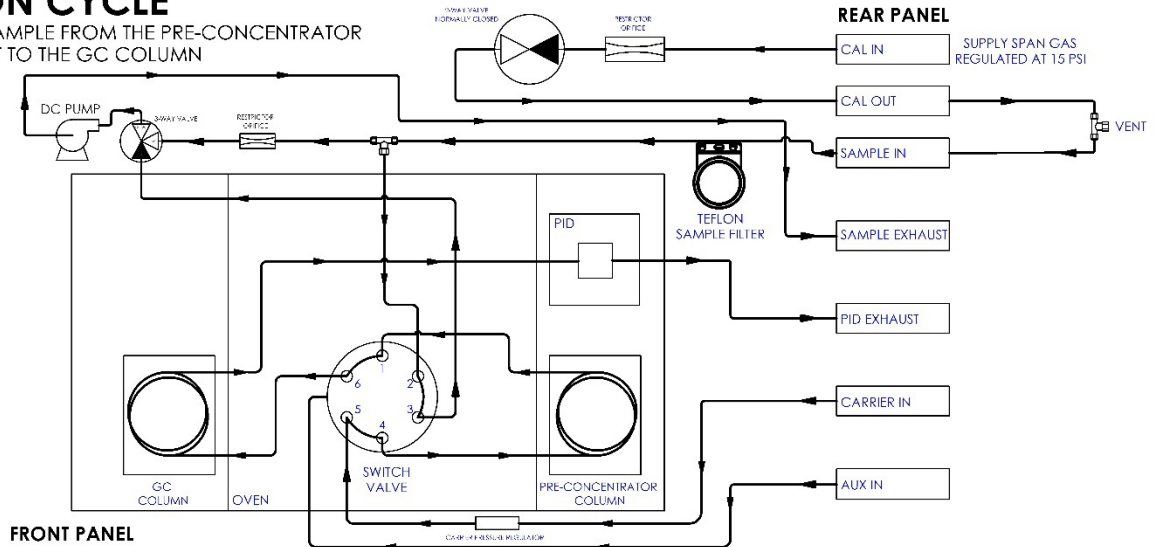

Figure 2-11. Pneumatic Flow for Sample and Injection Cycles with Pressurized Span Valve Option

2.3.4. STARTUP, FUNCTIONAL CHECKS AND CALIBRATION

We recommend reading Section 6 to become familiar with the principles of operation.

Note

It is expected that all cautionary messages are being followed.

2.3.4.1. POWER STATUS

The front panel Soft Power switch has a status LED that indicates whether:

- instrument is powered OFF (LED off)
- instrument powered on but internal components in sleep mode (LED blinking, achieved by pressing and momentarily holding the button)
- instrument powered on and internal components are operating (LED solid lit; never use the rear panel Hard Power switch when the front panel LED is solid lit).

When the instrument is first started (Section 2.3.4.2), check its functionality (Section 2.3.4.4). The analyzer is calibrated at the factory and no additional calibration should be required before operation begins. (However, if calibration is required, instructions are presented in Section 4).

Section 2.4 introduces the menu system, and Section 2.5 provides setup/customization instructions.

2.3.4.2. STARTUP

Upon initial startup, a sequence of status screens (Figure 2-12) appear prior to the Home page (Figure 2-13).

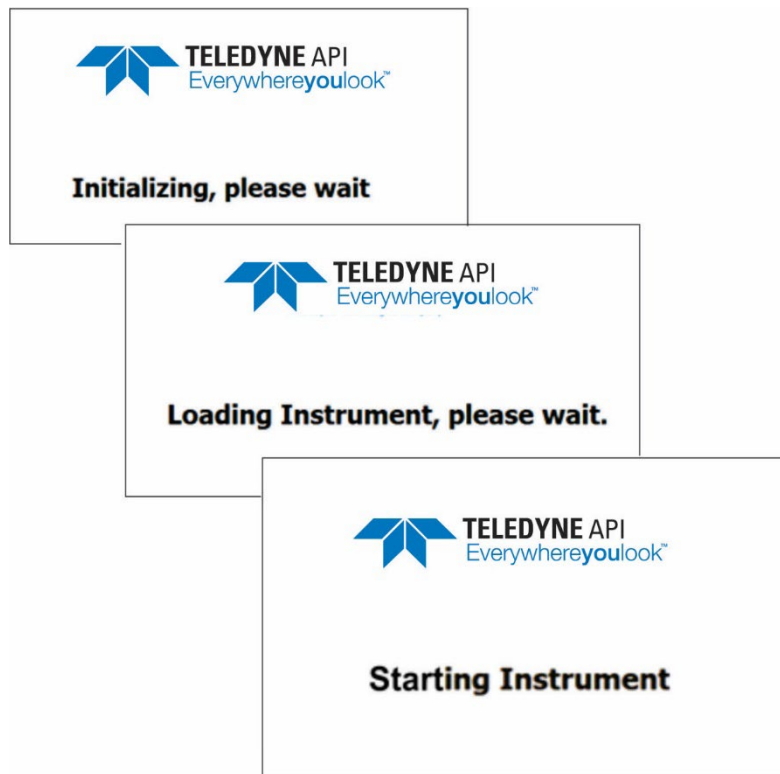

Figure 2-12. Status Screens at Startup

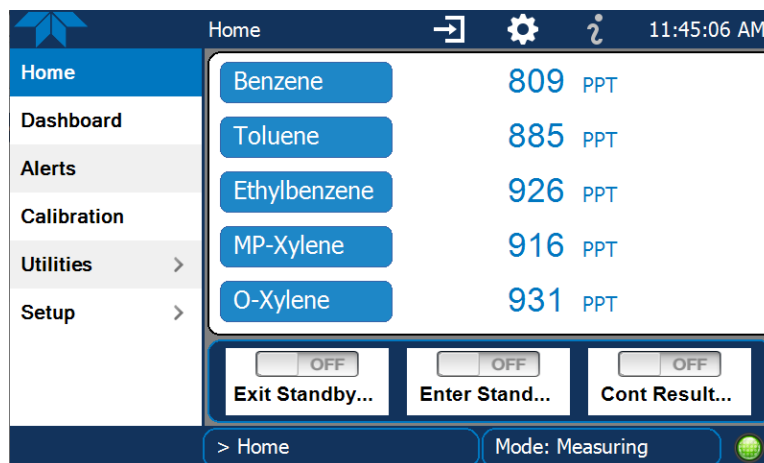

Figure 2-13. Home Page

Upon any startup, this instrument should warm up for approximately one hour before reliable measurements can be taken. The Mode field at the bottom of the interface indicates the various stages of warm-up from pre-ignition to sampling.

Note

If or when needed, sampling can be paused and resumed through the Enter Standby mode and Exit Standby mode features in either of two ways:

- Configure the Homescreen (Section 2.5.7) to include those controls in the meters at the bottom of the page (Figure 2-13) and slide the desired control switch to ON.
- Navigate to Setup>Vars>Enter Standby (or Exit Standby) and click the Edit button to change the setting to True.

2.3.4.3. ALERTS: WARNINGS AND OTHER MESSAGES

Because internal temperatures and other conditions may be outside the specified limits during the warm-up period, the software will suppress most Alerts for ~45 minutes after power up. The Alerts page (Figure 2-14) shows the status of any active warning conditions or user-configured Events. (Section 2.4.3 provides more detailed information about Alerts, and Section 2.5.2 addresses Events).

Alerts can be viewed and cleared via either the Alerts menu or the Alerts shortcut (Caution symbol, bottom right corner of the screen). Although these alerts can be cleared from the Active Alerts page, a history of all alerts remains in the Utilities>Alerts Log page.

Navigate to the Active Alerts page via the Alerts menu on Home screen.

(Also view a list of all active and past Alerts and Events via Utilities>Alerts Log).

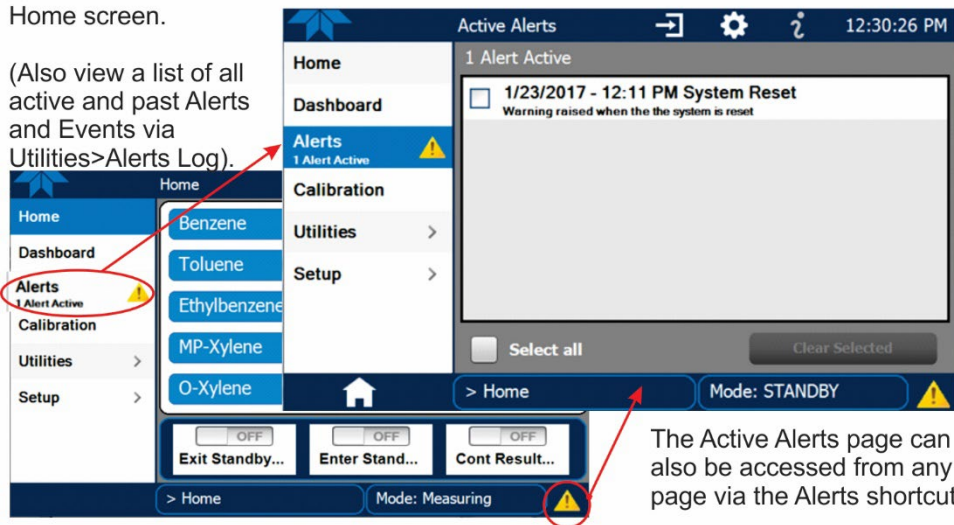

The Active Alerts page can also be accessed from any page via the Alerts shortcut.

Figure 2-14. Viewing Active Alerts Page

If Alerts about warning conditions persist after the warm-up period or after being cleared, investigate their cause using the troubleshooting guidelines in Section 5.5.1.

2.3.4.4. FUNCTIONAL CHECKS

After warm-up, verify that the software properly supports any hardware options that are installed (Setup>Instrument menu), and that the instrument is functioning within allowable operating parameters. View the Dashboard page to check that parameters show expected/reasonable values. (If any functional parameters are not displayed, configure the Dashboard through the Setup>Dashboard menu to add them; see Section 2.5.3). If GC Status tag shows “Not Ready” while Mode: field at bottom of interface shows “Startup,” it means that the instrument is warming up; if GC Status still shows “Not Ready” after 30-60 minutes, refer to Section 5.5.5.

Alerts serve as notifications if anything is not functioning properly.

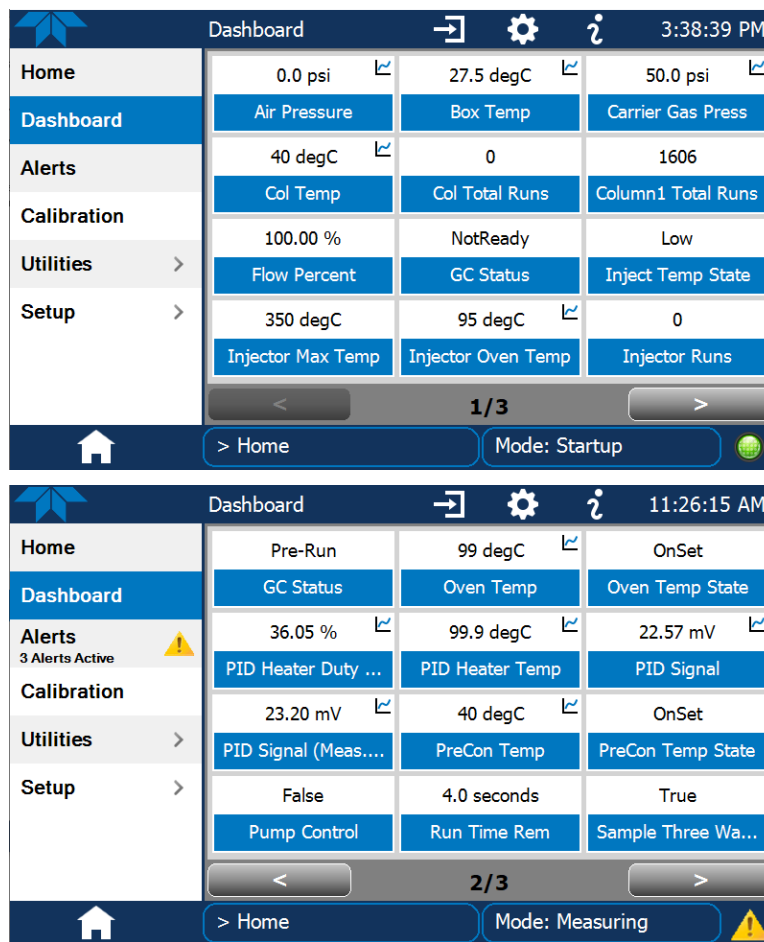

Figure 2-15. Sample Dashboard Pages

2.4. MENU OVERVIEW

Table 2-6 describes the main menus and provides cross-references to the respective sections with configuration details.

Table 2-6. Menu Overview

MENU	DESCRIPTION	LOCATION
Home	View and plot concentration readings and other selectable parameter values (Figure 2-17).	Section 2.4.1
Dashboard	View user-selected (via Setup menu) parameters and their values, some of which can be displayed in a live-plot graph	Section 2.4.2
Alerts	View and clear active Alerts triggered by factory-defined and user-defined Events. (Active and past Alerts are recorded in the Utilities>Alerts Log).	Section 2.4.3
Calibration	Run calibrations / calibration checks on the target analysis gas channel(s).	Sections 2.4.4, 4
Utilities	View logs, download data and firmware updates, copy configurations between instruments, run diagnostics, and calibrate linearity.	Section 2.4.5
Setup	Configure a variety of features and functions through these submenus for customized operation.	Section 2.5
Datalogging	Track and record concentration and calibration data and selectable diagnostic parameters, the reports for which can be viewed in the Utilities>Datalog View menu (Section 2.4.5) and downloaded to a flash drive via the Utilities>USB Utilities menu (Section 2.4.5). Also, select configured Events (Section 2.5.2) and create customized triggers for data logging functions.	Section 2.5.1
Events	Select parameters and define the conditions by which they are to be flagged and recorded in the Alerts log (Section 2.4.3) when they are triggered. Once configured, Events can be used to trigger Datalogs. (Section 2.5.1). Note that some Events are predefined and are not editable.	Section 2.5.2
Dashboard	Monitor instrument functionality (Figure 2-15) via selectable parameters.	Section 2.5.3
Auto Cal	With installed valve options, run automatic span cal check.	Section 4.3
Vars	Manually adjust several software variables that define specific operational parameters.	Section 2.5.5
GC Gas Config	Adjust the integration engine parameters.	Section 2.5.6
Homescreen	Select up to three parameters to display along bottom	Section 2.5.6
Digital Outputs (option)	Map the rear-panel digital outputs to a variety of signals present in the instrument to monitor the status of operating conditions or custom Events.	(with option)
Analog Outputs (option)	Send user-selected parameter readings in the form of user-defined voltage or current loop signals as outputs to a strip chart recorder and/or the data logger.	(with option)
Instrument	View product and system information, including list of options, if any; view network settings; view/adjust Date and Time settings*; and check for firmware updates when connected to a network that is connected to the Internet. *Time Zone change requires special procedures (Section 5.4).	Section 2.5.8
Comm	View and configure network and serial communications.	Section 2.5.10

2.4.1. HOME PAGE

Figure 2-16 presents an orientation to the main display screen; Figure 2-17 shows that pressing the gas name or its concentration value or a meter below displays a live plot of their respective readings. Section 2.5.6 provides configuration instructions.

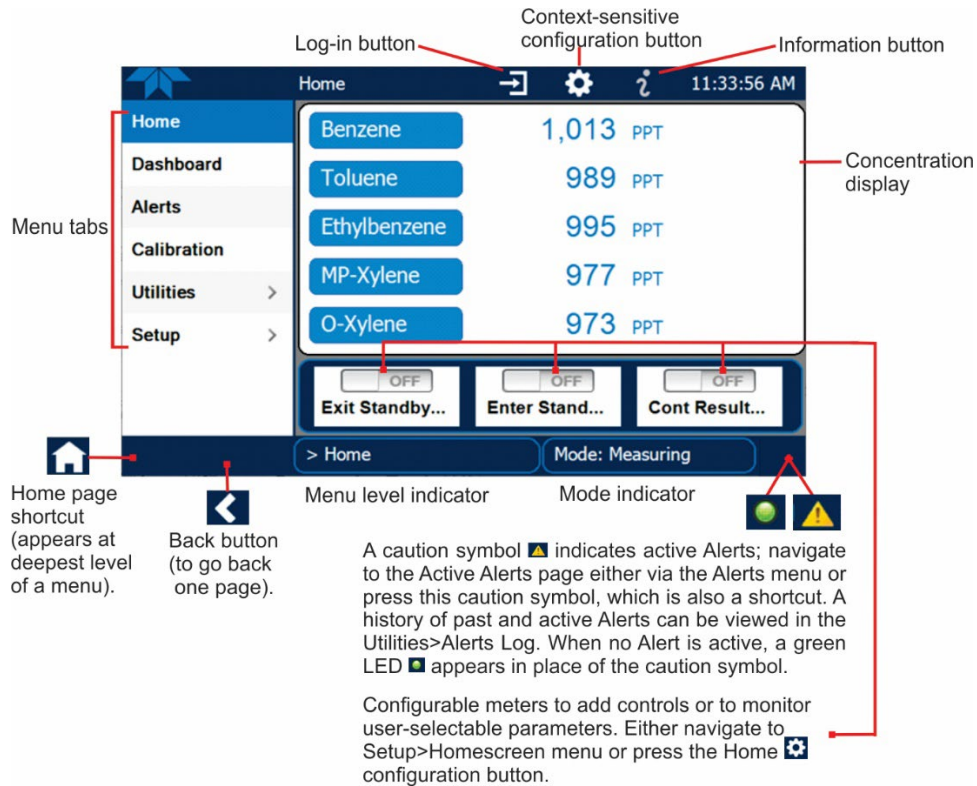
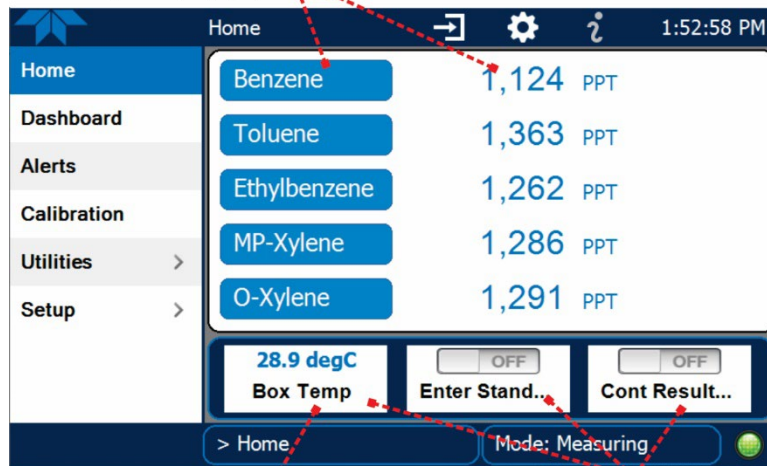

Figure 2-16. User Interface Orientation

Select either a gas name or its reading to display graph.



Select a graphable meter to display its graph.

Change meter display using the Home configuration button  or the Setup>Home menu.

Figure 2-17. Accessing Concentration Graph or Meter Graph from Home page

2.4.2. DASHBOARD

The Dashboard displays an array of user-selectable parameters and their values (Section 2.5.3 provides configuration instructions). If there is a graphing icon in the upper right corner of a parameter, pressing that parameter displays a live plot of its readings as in Figure 2-18.

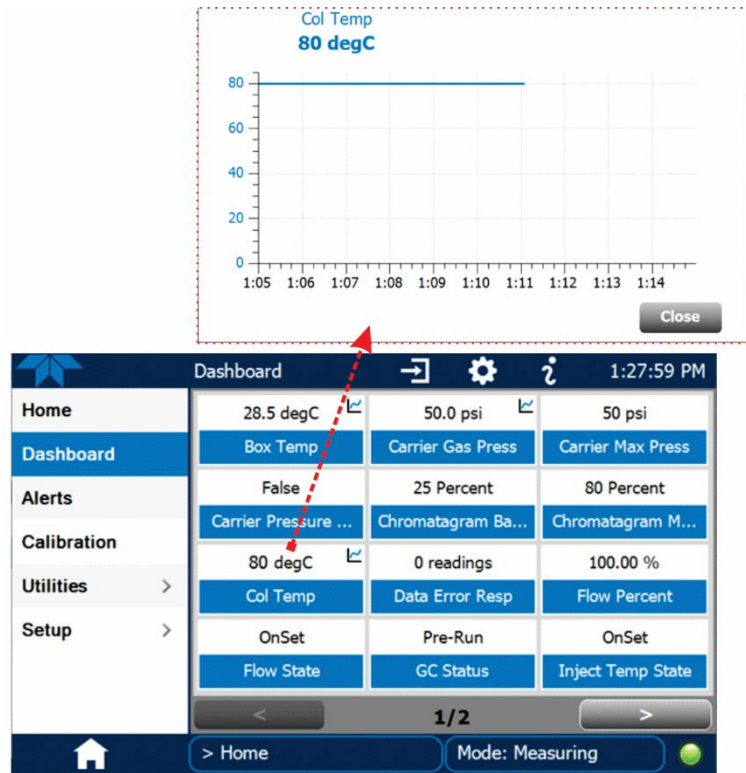

Figure 2-18. Parameter Graph from Dashboard Page

2.4.3. ALERTS

Alerts are notifications triggered by specific criteria having been met by either factory-defined conditions (standard and not editable) or user-defined Events (Section 2.5.2). The Active Alerts page shows the status of any active warning conditions or Events that have been triggered.

When Alerts are triggered, a caution symbol appears in both the Alerts menu tab and in the bottom right corner of the software interface, which serves as a shortcut to the Alerts page from any other page. View a list of currently active Alerts by pressing either the Alerts menu on the Home screen or by pressing the Alerts shortcut (Figure 2-19).

While Alerts can be cleared from the Active Alerts page, they remain recorded in the Utilities>Alerts Log menu.

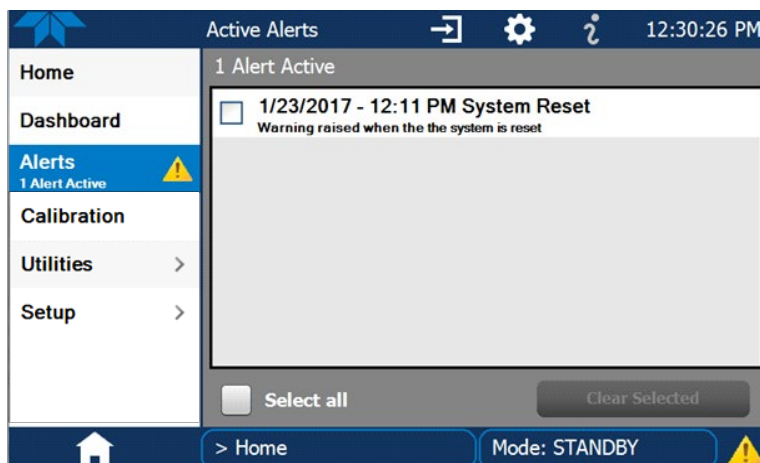

Figure 2-19. Active Alerts Page

Alerts can be configured as either latching (appears in Active Alerts screen when Event is triggered and must be cleared by the user) or non-latching (Active Alerts screen continuously updates based on the Event criteria, clearing on its own). See Section 2.5.2.

To clear Alerts from the Active Alerts page, either check individual boxes to choose specific Alerts, or check the Select All box to choose all Alerts, then press the Clear Selected button.

When all Alerts are cleared, the Alerts menu tab no longer shows the caution symbol, and a green LED replaces the caution symbol in the bottom right corner of the interface (Figure 2-20). However, Alerts can reappear if the conditions causing them are not resolved. For troubleshooting guidance, refer to Section 5.5.

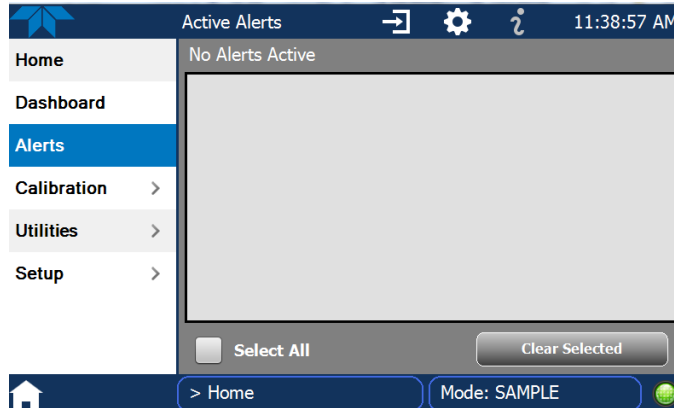

Figure 2-20. Active Alerts Cleared

Alerts and Events remain recorded in the Utilities>Alerts Log (Figure 2-21).

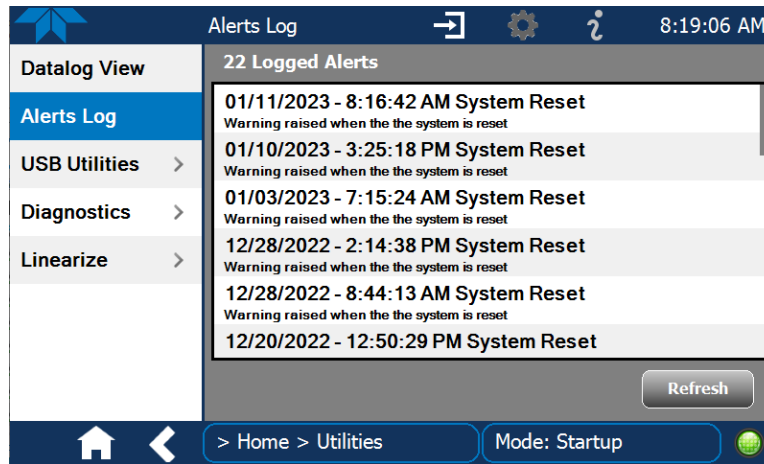

Figure 2-21. Utilities>Alerts Log of Active and Past Alerts and Events

2.4.4. CALIBRATION

The Calibration menu is used for span calibrations and for external calibration with valve options installed. Calibration procedures are presented in Section 4.

2.4.5. UTILITIES

The Utilities menu has a variety of functions as described next in Table 2-7.

Table 2-7. Utilities Submenu Descriptions

UTILITIES MENU	DESCRIPTION	
Datalog View	Displays the data logs that were configured via the Setup>Data Logging menu. From this list a log can be selected and filters applied to view the desired data. (For details on setting up and running the Data Logger, see Section 2.5.1).	
Alerts Log	Displays a history of alerts that are triggered by factory-defined and user-defined Events, such as warnings and alarms (See Section 2.5.2 for Events configuration).	
USB Utilities	Serves multiple purposes using a flash drive connected to the instrument's front panel USB port: <ul style="list-style-type: none"> • download data from the instrument's Data Acquisition System (DAS), the Data Logger, to a flash drive (Section 2.5.1.3) • update firmware (Section 5.2) • transfer instrument configuration from/to other same-model instruments (Section 2.6) • download a basic operation functionality report (Section 5.2). 	
Diagnostics	Provides access to various pages that facilitate troubleshooting.	
	Analog Inputs	Shows the raw voltage of preconfigured parameter.
	Analog Outputs (Option)	Shows the Voltage or Current signals for the functions selected and configured in the Setup>Analog Outputs menu. (Section 2.3.1.2 presents the rear panel connections).
	Digital Inputs	Show whether specific available features are turned ON or OFF; input controls are fixed; output controls and relays are configurable in the Setup> Digital Outputs menu. (Section 2.3.1.3 presents the rear panel connections).
	Digital Outputs	Show whether specific available features are turned ON or OFF; input controls are fixed; output controls and relays are configurable in the Setup> Digital Outputs menu. (Section 2.3.1.3 presents the rear panel connections).
Linearize	Interpolates linear points to calculate concentration based on peak area.	
	Cyl Gas Config	Manually adjust the concentration for each of the five gases by inputting the value of the gases as listed on the calibration cylinder certification. These are undiluted values.
	Dilution Config	Manually adjust the dilution flow and/or the source flow for each linear point; displays the calculated dilution ratio.
	Linearize Store	Facilitates linearizing the data for each of four linear points.
	View Table	Displays concentrations, areas and heights for the five gases at each linearity point.

2.4.6. SETUP

The Setup menu is used to configure the instrument's various features, functions, and data log. Section 2.5 provides details for the menus under Setup.

2.5. SETUP MENU: FEATURES/FUNCTIONS CONFIGURATION

Use the Setup menu to configure the instrument’s software features, to gather information on the instrument’s performance, and to configure and access data from the Datalogger, the instrument’s internal data acquisition system (DAS). Once the setups are complete, the saved configurations can be downloaded to a USB drive through the Utilities>USB Utilities menu and uploaded to other instruments of the same model (Section 2.6).

2.5.1. SETUP>DATA LOGGING (DATA ACQUISITION SYSTEM, DAS)

The Datalogger can be configured to capture and store user-defined data, which then can be viewed in the Alerts page, if elected, as well as downloaded from the instrument to a USB flash drive or using NumaView™ Remote software for examination and analysis.

Figure 2-22 shows a new log; Figure 2-23 shows a sample existing log, which can be edited or deleted, and Figure 2-24 provides illustrated instructions for setting up a new log, with Sections 2.5.1.1 and 2.5.1.2 providing additional details.

To transfer captured instrument data to a flash drive, see Section 2.5.1.3.

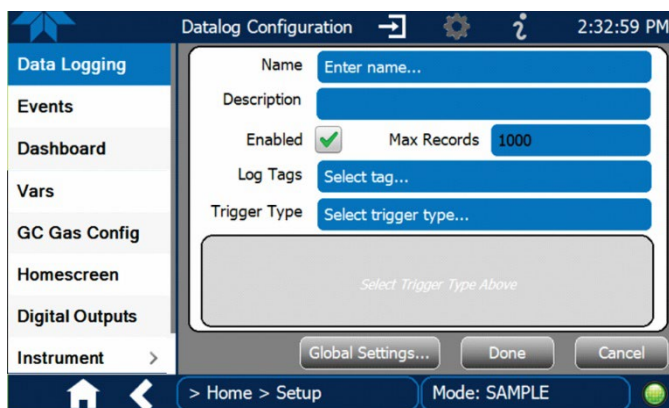

Figure 2-22. Datalog Configuration, New Log Page

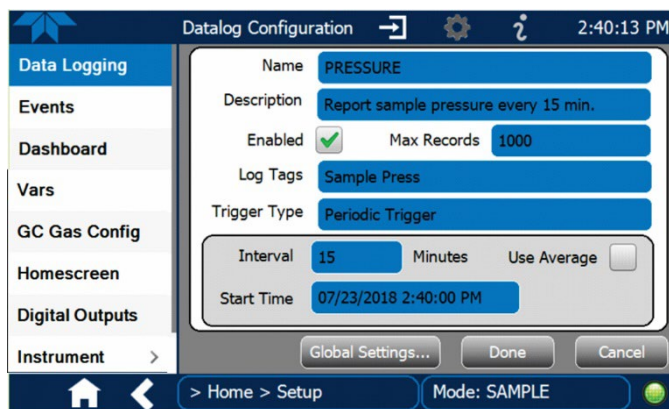
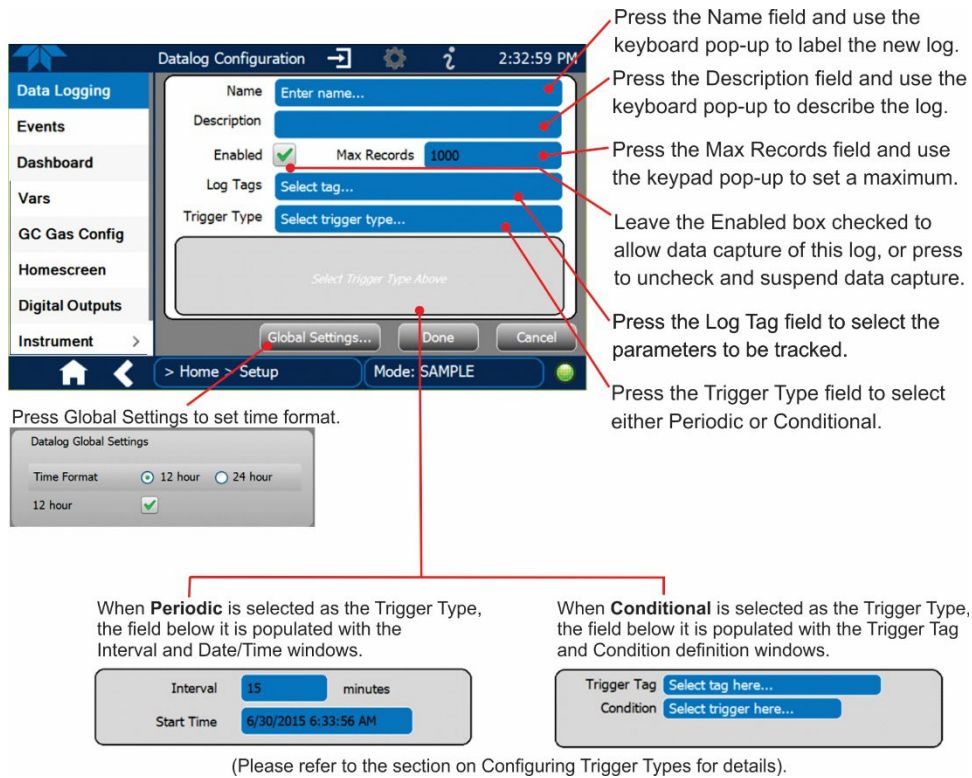

Figure 2-23. Datalog Configuration, Existing Log



Press the Name field and use the keyboard pop-up to label the new log.
 Press the Description field and use the keyboard pop-up to describe the log.
 Press the Max Records field and use the keypad pop-up to set a maximum.
 Leave the Enabled box checked to allow data capture of this log, or press to uncheck and suspend data capture.
 Press the Log Tag field to select the parameters to be tracked.
 Press the Trigger Type field to select either Periodic or Conditional.

Press Global Settings to set time format.

When **Periodic** is selected as the Trigger Type, the field below it is populated with the Interval and Date/Time windows.

When **Conditional** is selected as the Trigger Type, the field below it is populated with the Trigger Tag and Condition definition windows.

(Please refer to the section on Configuring Trigger Types for details).

Figure 2-24. Creating a New Data Log

The parameters available in the list of Log Tags include the names of Events configured in the Events page (Section 2.5.2).

2.5.1.1. CONFIGURING TRIGGER TYPES: PERIODIC

The Periodic trigger is a timer-based trigger that is used to log data at a specific time interval. Periodic Trigger requires an interval that is set to number of minutes and a start time that is set to date and clock time.

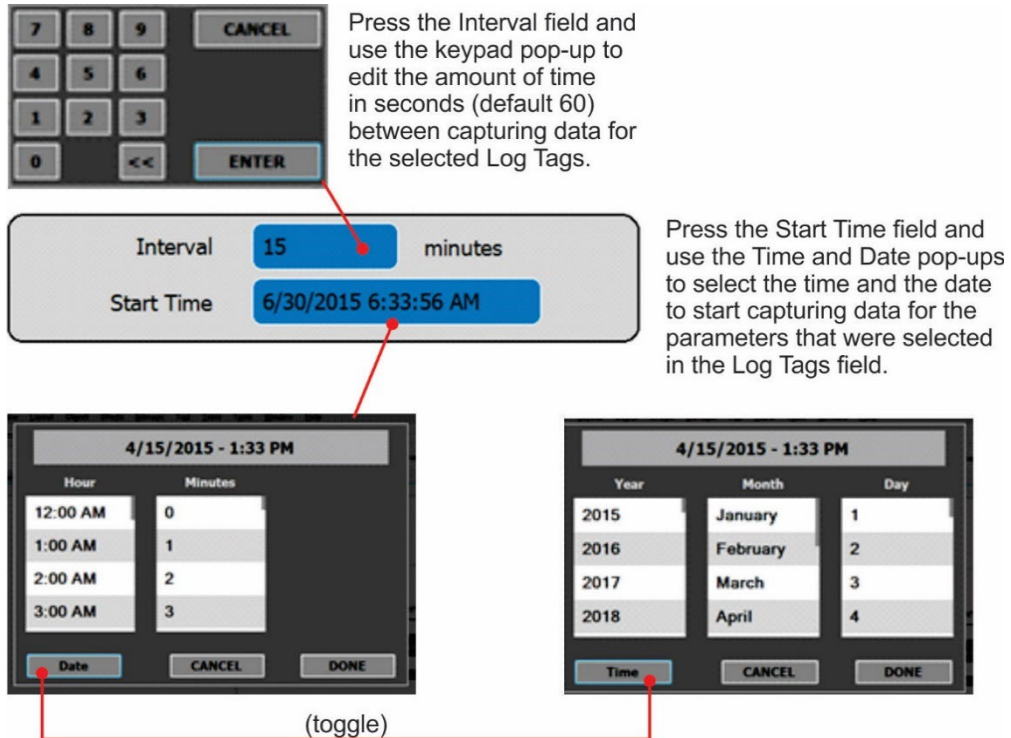

Press the Interval field and use the keypad pop-up to edit the amount of time in seconds (default 60) between capturing data for the selected Log Tags.

Press the Start Time field and use the Time and Date pop-ups to select the time and the date to start capturing data for the parameters that were selected in the Log Tags field.

(toggle)

Figure 2-25. Datalog Periodic Trigger Configuration

2.5.1.2. CONFIGURING TRIGGER TYPES: CONDITIONAL

Conditional Trigger tracks/records data for user-selected parameters that meet specified conditions.

Press the Trigger Tag field and select a parameter to be tracked/logged. A default Condition associated with the selected Tag will populate the Condition field.

Press the Condition field to select a different choice from the condition list.

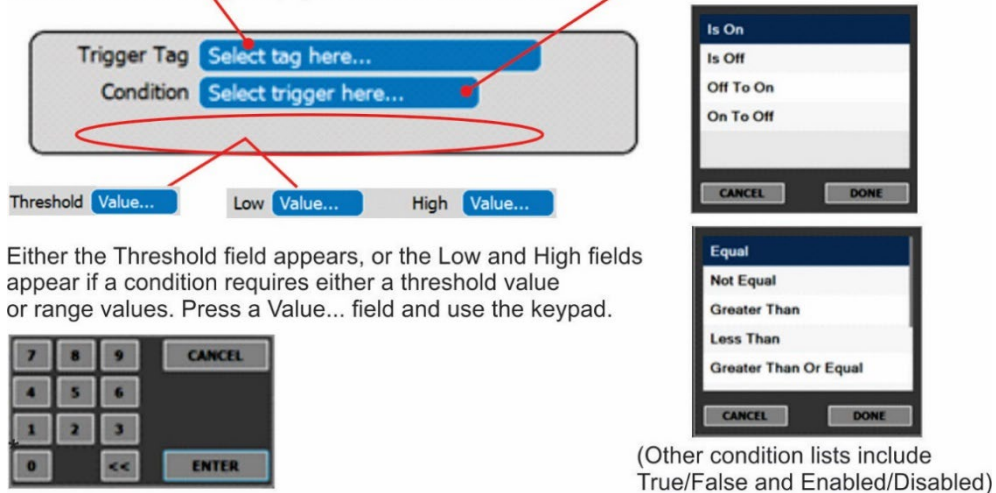

Figure 2-26. Datalog - Conditional Trigger Configuration

2.5.1.3. DOWNLOADING DAS (DATA ACQUISITION SYSTEM) DATA

To download DAS data collected by the Datalogger from the instrument to a flash drive, navigate to the Utilities>USB Utilities>DAS Download menu.

1. Insert a flash drive into a front panel USB port and wait for the Status field to Indicate that the drive has been detected; available buttons will be enabled.

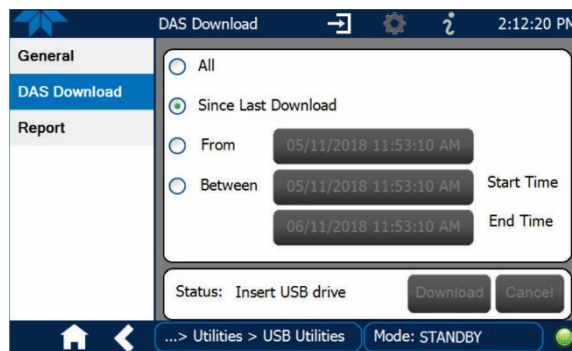

Figure 2-27. DAS Download Page

2. Select all or define a period from which to download the collected data.
3. Press the Download button, and when complete, as indicated in the Status field, press the Done button (changed from “Cancel”) and remove the flash drive.

2.5.2. SETUP>EVENTS

Events are occurrences that relate to any operating function and are used to define the conditions that can be set to trigger Alerts (Section 2.4.3). Events can provide diagnostic information about the instrument, typically referred to as “Warnings”, or they can provide other information on instrument functionality, such as concentration alarms. Some Events are standard and not editable while others are user-configurable, described here. Existing Events are listed in the Events page (Figure 2-28) under the Setup menu.

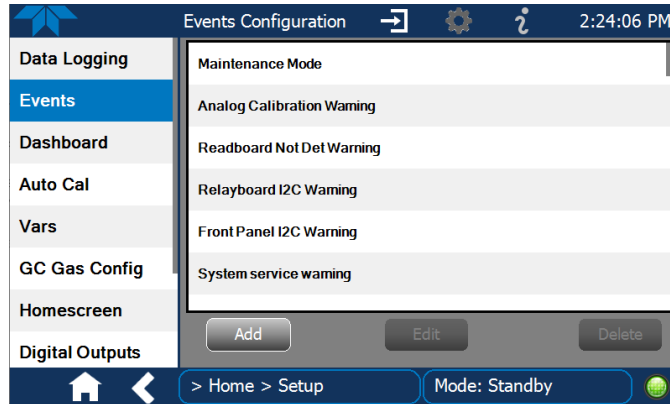

Figure 2-28. Example Events List

Access the Events Configuration page either from the Active Alerts page (Alerts Menu) by pressing the configuration button, or through the Home>Setup>Events menu (Figure 2-28). Press ADD to create a new Event (refer to Figure 2-29 for details), or select an existing Event to either Edit or Delete it (Figure 2-31).

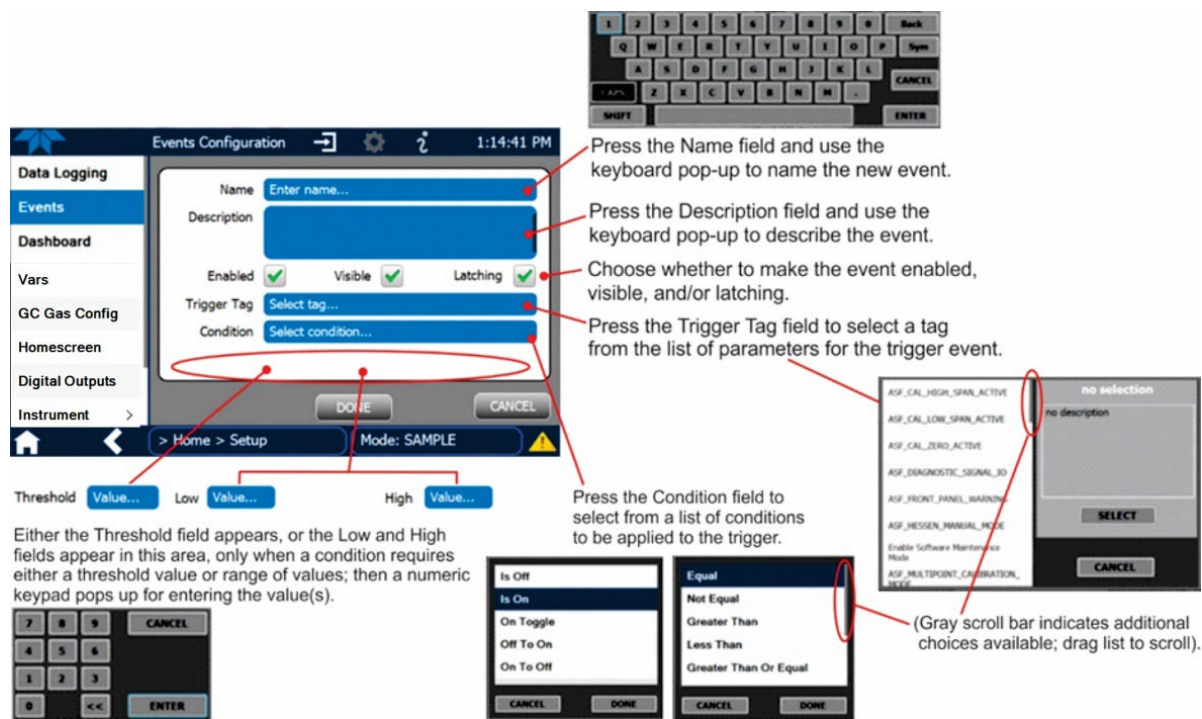

Figure 2-29. Event Configuration

- Enabled allows the choice of whether to track and record the Event (uncheck this box to “turn off” or deactivate the Event without deleting it). An Event must be enabled in order to use the Visible and the Latching options.
- Visible allows the choice of whether or not to display the Event in the Alerts page when it is triggered (it will still be recorded and can be viewed in the Utilities>Alerts Log). To use this option, the Event must be enabled.
- Latching allows the choice of whether or not to keep an Event visible even if the conditions that triggered it were to correct themselves. (Latching requires that the user interact with the Active Alerts screen to manually clear the Alert and internal Event state. Non-latching allows the entry in the Active Alerts screen and the internal Event state to continuously update based on the Event criteria, requiring no user interaction to clear the Alert or Event state).

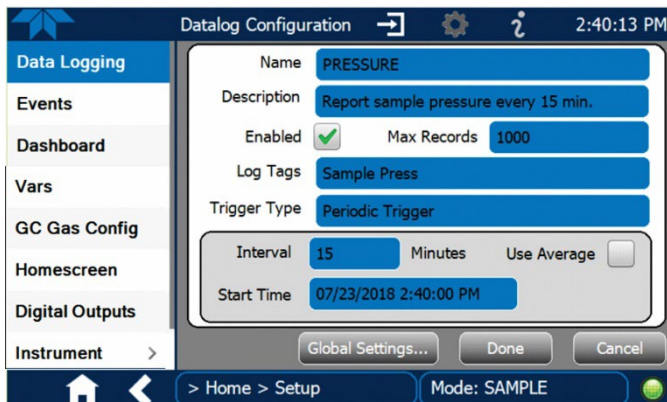
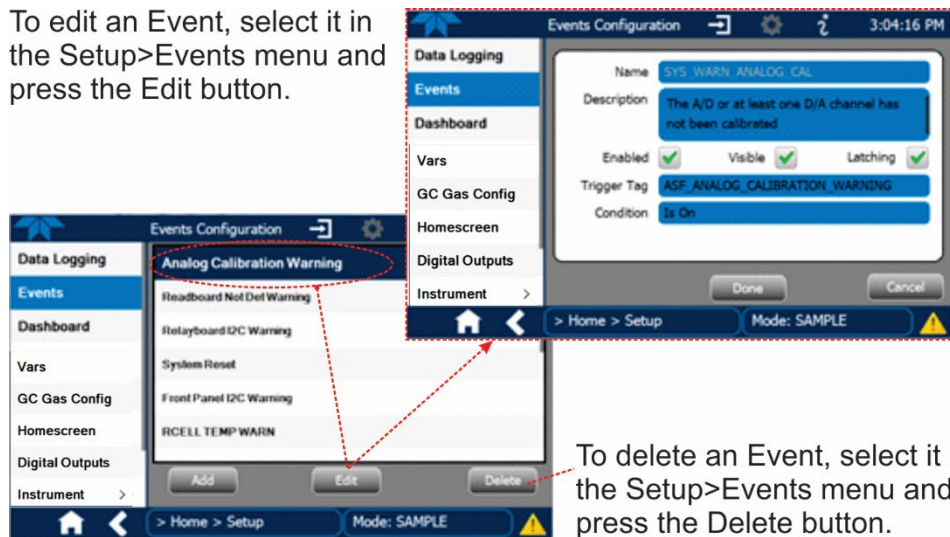

Figure 2-30. Configured Event Sample

2.5.2.1. EDITING OR DELETING EVENTS

Select an Event from the list (Figure 2-28) and press the Edit button to view or edit the details (Figure 2-30), or press the Delete button to delete the Event.

To edit an Event, select it in the Setup>Events menu and press the Edit button.



To delete an Event, select it in the Setup>Events menu and press the Delete button.

Figure 2-31. Edit or Delete an Event

2.5.2.2. USING EVENTS AS TRIGGERS FOR DATA LOGGING

Events can also be used to create customized triggers for data logging functions. The name entered in the Name field of the Events Configuration page will appear in the list of Log Tags of the Datalog Configuration page. The Data Logger is presented in Section 2.5.1.

2.5.3. SETUP>DASHBOARD

To navigate to the Dashboard Configuration page either press the configuration shortcut from the Dashboard page, or use the Setup>Dashboard menu.

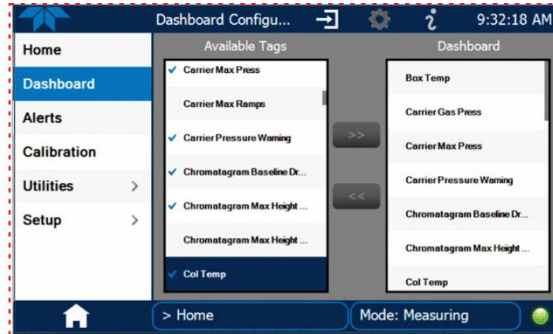

Configuration Shortcut

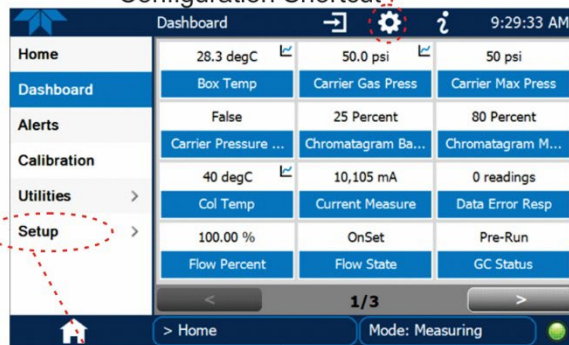

Configuration Editing:

To add a parameter to the Dashboard, select it in the “Available Tags” list and press the right-pointing arrows button. (Checkmarks in the “Available Tags” list indicate parameters that are currently in the Dashboard).

To remove a parameter from the Dashboard, select it from the “Dashboard” list and press the left-pointing arrows button.

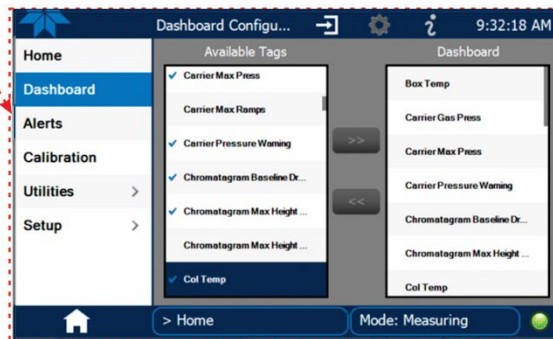

Figure 2-32. Dashboard Display and Configuration

2.5.4. SETUP>AUTOCAL (WITH VALVE OPTION)

Auto Cal is available with installed valve options for use in performing an automatic span calibration check (see Section 4.3).

2.5.5. SETUP>VARS

Vars are user-adjustable software variables that define operational parameters automatically set by the instrument's firmware. Table 2-8 lists and describes the key Vars for this instrument along with their default values; Table 2-9 lists and describes general Vars. Access the menu to see the list of variables; select a variable to view its description; use the Edit button to change its setting(s).

Table 2-8. Key Variables with Default Values and Descriptions

VAR NAME	DEFAULT VALUE	DESCRIPTION
Acquisition Time	500 Sec	The total time in seconds for capturing data during each run of Measurement mode.
Carrier Initial Press	50 Psig	The initial pressure for the carrier gas
Carrier Gas Initial Hold	1 Sec	The duration for maintaining the initial Carrier gas
Carr Gas Ramp1 Rate	0 Psig/s	The Psig/Sec rate at which the carrier gas ramping up/down during Ramp 1 mode (0 value to disable the ramping).
Column Initial Hold time	80 Sec	The duration for maintaining the initial column temperature at the start of Measurement mode
Column Initial Temp	80 DegC	The initial column temperature at the start of Measurement mode
Column Ramp 1 Hold	390 Sec	The duration for maintaining the temperature reached when the column is heated up during Ramp 1 Measurement mode
Column Ramp 1 Rate	1 DegC/s	The DegC/Sec rate at which the column is heated up during Ramp 1 Measurement mode
Column Ramp 1 Temp	130 DegC	The setpoint that the column temperature reaches during Ramp 1 Measurement mode
Column Ramp 2 Rate	3 DegC/s	The DegC/Sec rate at which the column is heated up during Ramp 2 Measurement mode (0 value to disable the ramping).
Column Ramp2 Hold	90 Sec	The duration for maintaining the temperature reached when the column is heated up during Ramp 2 Measurement mode
Column Ramp2 Temp	190 DegC	The setpoint that the column temperature reaches during Ramp 2 Measurement mode
Cylinder Concentration User Units	PPT	The units used for entering the BTEX cylinder concentration, that will be used on the linearization menu
DC Pump Fill Time	180 Sec	The duration of filling the Pre-Concentrator with the sample before the start of each run.
Generate Cont. Data	TRUE	Enable the continuous results table
Enter Standby Mode	FALSE	Manually enter the Standby mode
Exit Standby Mode	FALSE	Manually exit the Standby mode
Linearity Number of Points	5	Number of points that will define the linearization table
Oven Temp Setpoint	100 DegC	The temperature setpoint of the main oven
PID Auto Zero Time	20 Sec	The duration of zeroing the baseline before injecting the sample
PID Heater Temp Set Point	100 DegC	The temperature setpoint of the PID sensor
PreCon initial hold	0 Sec	The duration for maintaining the initial Pre-Concentrator temperature at the start of Measurement mode
PreCon Initial Temp	40 DegC	The initial Pre-Concentrator temperature at the start of Measurement mode
PreCon Ramp 1 Hold	33 Sec	The duration for maintaining the temperature reached when the Pre-Concentrator is heated up during Ramp 1 Measurement mode

VAR NAME	DEFAULT VALUE	DESCRIPTION
PreCon Ramp 1 Rate	20 DegC/s	The DegC/Sec rate at which the Pre-Concentrator is heated up during Ramp 1 Measurement mode
PreCon Ramp 1 Temp	180 DegC	The setpoint that the Pre-Concentrator temperature reaches during Ramp 1 Measurement mode
PreCon Ramp 2 Rate	0 DegC/s	The DegC/Sec rate at which the Pre-Concentrator is heated up during Ramp 2 Measurement mode (0 value to disable the ramping)
PRIGAS Precision	0	Sets the number of significant digits to the right of the decimal point display of primary gas concentration and stability values. ("PRIGAS" = primary gas with two or more other gases; "SECGAS" = secondary gas)
Pump Start Time	20 Sec	The period before the end of the run to activate the pump for the new injection
Switch Time Valve Pos. A1	5 s	The amount of time for turning the switch valve to position B
Switch Time Valve Pos. B1	415 s	The amount of time for turning the switch valve to position A
Used PID Gain	1X	PID Signal multiplexer gain configuration. Note: gain configuration change requires recalibrating the linearity (Section 4.4).

Table 2-9. Common Variables with Descriptions

VARIABLE	DESCRIPTION
<p>This list includes several of the most common Vars; selecting any Var in the NumaView™ software interface will display its description in the information field to its right. Depending on configuration, some, all, or more of these variables appear in your instrument's Vars menu.</p>	
Background Periodic Report Upload	Allows/disallows automatic, periodic uploading of basic functionality reports to a Web services "cloud" for TAPI Technical Support to view. (Frequency can be edited in Setup>Vars>Report Upload Interval).
Daylight Savings Enable	Enable or disable Daylight Savings Time (also see Setup>Instrument>Date/Time Settings)
Instrument ID	Set unique identifier number for the instrument when it is connected with other instruments on the same Ethernet LAN, or when applying MODBUS protocol.
Maint Mode	Enables (True) or does not enable (False) the trigger for software maintenance mode for the duration set in the Maintenance Mode Timeout Var..
Maintenance Mode Control	Specifies whether maintenance is to be controlled in Software mode (used in conjunction with the Maint Mode Var being set to True and the Maintenance Mode Timeout var being set to a time limit being set in ""), Switch mode (hardware switch behind front panel), or Both software and switch modes, or None.
Maintenance Mode Timeout	Sets the duration of software controlled maintenance after which amount of time the instrument is taken out of maintenance mode.
Periodically Check for Updates	Set this parameter to True for the instrument to check the cloud platform for firmware updates via the Internet.
PRIGAS Precision	Sets the number of significant digits to the right of the decimal point display of primary gas concentration and stability values. ("PRIGAS" = primary gas with two or more other gases; "SECGAS" = secondary gas)

VARIABLE	DESCRIPTION
Report Upload Interval	Set the frequency in number of hours at which the instrument's functional conditions are uploaded to the cloud platform (default, 168 hours, generates a weekly report).
SECGAS Precision	Sets the number of significant digits to the right of the decimal point display of secondary gas concentration and stability values. ("PRIGAS" = primary gas with two or more other gases; "SECGAS" = secondary gas)
System Hours	Total runtime hours for the system (similar to a car's total miles vs trip miles).
System Service Interval	Set the number of hours until the next service is due.
Time Since Last Service	Tracks the number of hours since the instrument was most recently serviced.
Upload Report to Cloud	For immediate upload of functionality report to cloud before next interval upload.

2.5.6. SETUP>GC GAS CONFIG

This menu is for adjusting the integration engine of the software, typically where the peak starts and ends for a gas. Select the gas, then select the parameter to adjust (the lower right area of the interface provides a brief description) and press the Edit button to make the adjustment. Figure 2-33 shows a sample screen for this menu.

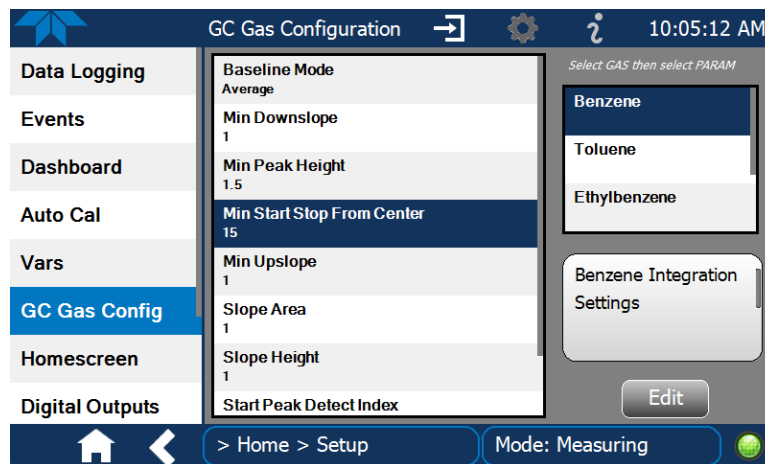

Figure 2-33. GC Gas Configuration

Table 2-10. GC Gas Configuration Descriptions

GC Configuration Parameter	Description
Baseline Mode	Choose peak area calculation method: Average (default): Draws a direct baseline from the peak's start point and stop point. Minimum or Maximum : Draws a horizontal baseline from the user-selected Min/Max Start peak point or Stop peak point. Start or Stop : Draws a horizontal baseline from Start point or End point.
Min Downslope	The minimum slope (From the peak tip to the end point) to be accepted. Default value is 1).
Min Peak Height	Input a peak height threshold where the peak area is ignored (shown as zero) if peak height falls below the threshold.
Min Start Stop From Center	The minimum distance (raw data points) of the peak's end to the peak's tip. Default value is 15 for all BTEX elements, except the MP-Xylene, which it is 180.
Min Upslope	The minimum slope (From the start point to the peak tip) to be accepted. Default value is 1.
Slope Area	Peak area slope value. Default value is 1.
Slope Height	Peak height slope value. Default value is 1.
Start Peak Detect Index	Start point for the peak channel
Stop Peak Detect Index	Stop point for the peak channel

2.5.7. SETUP>HOMESCREEN

To select a parameter (“tag”) for display in each of the three meters at the bottom of the Home page, navigate to the Homescreen configuration page through either the Setup>Homescreen menu or from Home page using the configuration icon (Figure 2-34).

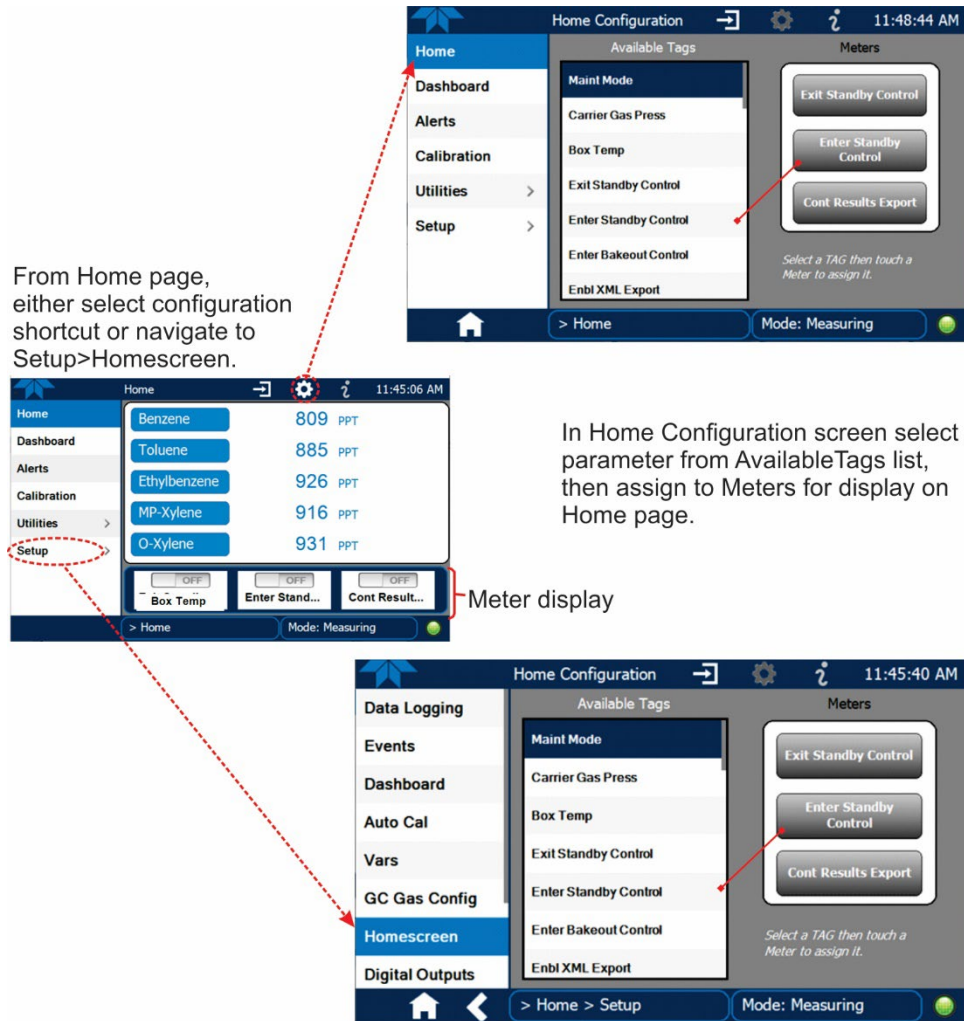

Figure 2-34. Homescreen Configuration

An orientation to the Homescreen was presented in Section 2.4.1, including Figure 2-16 and Figure 2-17.

2.5.8. SETUP>DIGITAL OUTPUTS (OPTION)

Specify the function of up to five digital outputs and three relays (connected through the rear panel Digital I/O connector, Figure 2-5) by mapping the outputs to a selection of “Signals” present in the instrument. Create custom “Signals” in the Setup>Events menu (Section 2.5.2).

To specify the outputs and/or relays, select a pin in the Outputs list, then make a selection from the Signals list and press the Map button; if/as needed, change the polarity by pressing the Polarity button. Save any changes by pressing the Apply button, or discard the changes by pressing the Home or the back button (a pop-up provides a warning that the changes will be lost, and will prompt for confirmation to apply changes or not).

Navigate to the Utilities>Diagnostics>Digital Outputs menu to change the state (ON/OFF) of individual digital outputs.

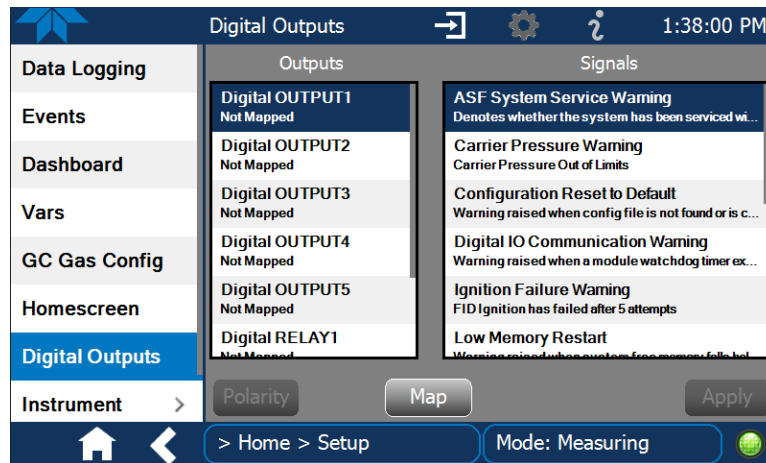

Figure 2-35. Digital Outputs Setup

2.5.9. SETUP>INSTRUMENT

As presented in Table 2-11, view product and system information and network settings, edit network settings, and perform certain maintenance tasks.

Table 2-11. Setup>Instrument Menu

MENU	DESCRIPTION
Product Info	View Model, Part, and Serial Numbers and Package and Driver Versions, and options information.
System Info	View Windows and RAM information.
Module Info	Shows the model and serial number of each module included.
Network Settings	View the network settings (configurable through the Setup>Comm>Network Settings menu).
Date/Time Settings	Adjust date, hour, and minutes, select a time zone*, and set the system clock to automatically adjust for Daylight Savings Time or not. (Also see Setup>Vars>Daylight Savings Enable). *Time Zone change requires a special procedure; see Maintenance Section 5.4.
NTP Time Settings	Configure Network Time Protocol settings for clock synchronization.
Language	Select an available language.
Remote Update	When an instrument is connected to a network that is connected to the Internet, follow the instructions on this Remote Update page to check for and activate software/firmware updates. (Also refer to Section 5.2).

2.5.10. SETUP>COMM (COMMUNICATIONS)

This menu is for specifying the various communications configurations.

2.5.10.1. COM1

Configure the instrument's COM port to operate in modes listed in Table 2-12.

Table 2-12. COM1 Setup

MODE	DESCRIPTION
Baud Rate	Set the baud rate.
Command Prompt Display	Enable/disable a command prompt to be displayed when in terminal mode.
Data Bits	Set the data bits to 7 or 8 (typically set in conjunction with Parity and Stop bits).
Echo and Line Editing	Enable/disable character echoing and line editing.
Handshaking Mode	Choose SOFTWARE handshaking for data flow control (do NOT use SOFTWARE handshaking mode when using MODBUS RTU for Protocol mode; select only HARDWARE or OFF for MODBUS RTU), or HARDWARE for CTS/RTS style hardwired transmission handshaking. (This style of data transmission handshaking is commonly used with modems or terminal emulation protocols). Or choose to turn OFF handshaking.
Hardware Error Checking	Enable/disable hardware error checking.

MODE	DESCRIPTION
Hardware FIFO	Enable/disable the hardware First In – First Out (FIFO) for improving data transfer rate for that COM port.
Modem Connection	Select either a modem connection or a direct cable connection.
Modem Init String	Input an initialization string to enable the modem to communicate.
Parity	Select odd, or even, or no parity (typically set in conjunction with Data Bits and Stop Bits).
Protocol	Select among the communications protocols: MODBUS RTU, MODBUS ASCII, HTTP over Serial, Hessen.
Quiet Mode	Enable/disable Quiet mode, which suppresses any feedback from the analyzer (such as warning messages) to the remote device and is typically used when the port is communicating with a computer program where such intermittent messages might cause communication problems. Such feedback is still available, but a command must be issued to receive them.
Security	Enable/disable the requirement for a password for this serial port to respond. The only command that is active is the request-for-help command, ? CR .
Stop bits	Select either 0 or 1 stop bit (typically set in conjunction with Parity and Data bits).

2.5.10.2. TCP PORT1

TCP Port1 allows choosing whether or not to display the command prompt, editing the Port 1 number for defining the terminal control port by which terminal emulation software addresses the instrument, such as Internet or NumaView™ Remote software, and enabling or disabling security on this port.

2.5.10.3. TCP PORT2

TCP Port2 is configured with the port number for MODBUS.

2.5.10.4. NETWORK SETTINGS

The Setup>Comm>Network Settings menu is for Ethernet configuration. The address settings default to automatic configuration by Dynamic Host Configuration Protocol (DHCP). Most users will want to configure the instrument with a static IP address: click the Static radio button to manually assign a static IP address (consult your network administrator and see Table 2-13 for information).

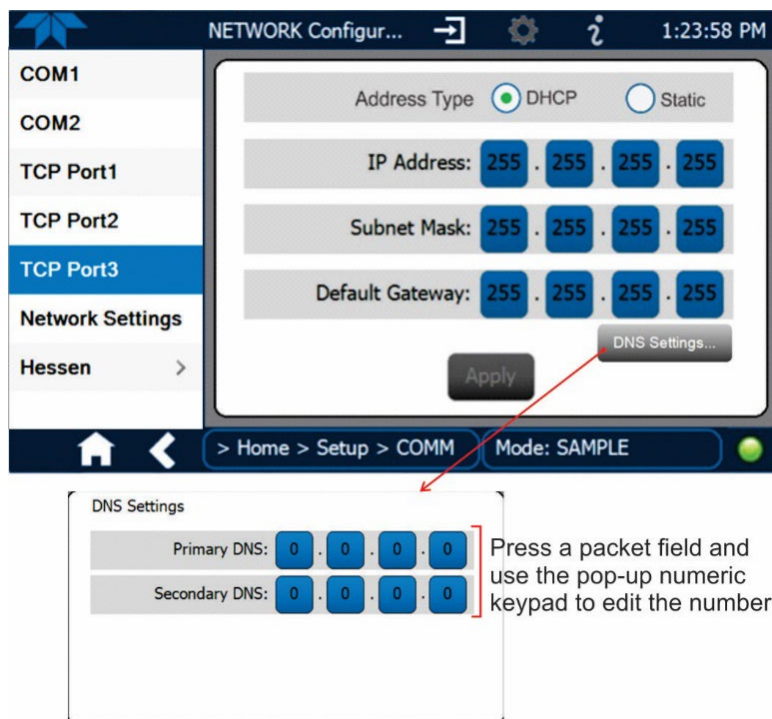

Figure 2-36. Communications Configuration, Network Settings

Table 2-13. LAN/Ethernet Configuration Properties

PROPERTY	DESCRIPTION
IP address	A string of four packets of 1 to 3 numbers each (e.g. 192.168.76.55.) is the internet protocol address of the instrument itself.
Subnet Mask	A string of four packets of 1 to 3 numbers each (e.g. 255.255.252.0) number that masks an IP address, and divides the IP address into network address and host address and identifies the LAN to which the device is connected. All addressable devices and computers on a LAN must have the same subnet mask. Any transmissions sent to devices with different subnets are assumed to be outside of the LAN and are routed through the gateway computer onto the Internet.
Default Gateway	A string of numbers very similar to the Instrument IP address (e.g. 192.168.76.1) that is the address of the computer used by your LAN and serves as a router to access the Internet or another network.

2.6. TRANSFERRING CONFIGURATION TO OTHER INSTRUMENTS

Once an instrument is configured, the same configuration can be copied to other instruments of the same Model. This encompasses essentially anything the user can configure and does not apply to instrument-specific settings such as those that are configured at the factory for calibration.

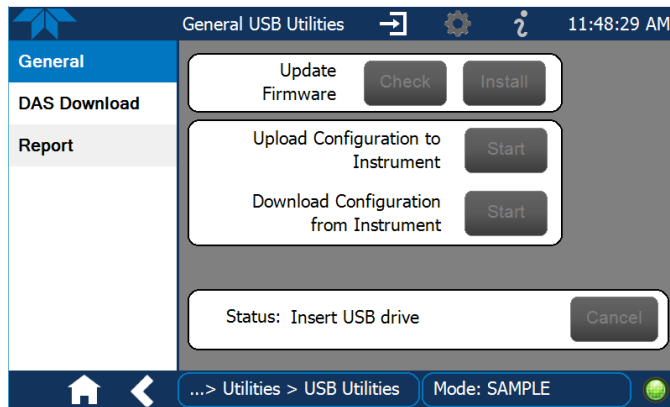

Figure 2-37. Configuration Transfer

1. In the source instrument, go to the Home>Utilities>USB Utilities>General page.
2. Insert a flash drive into either of the two front panel USB ports.
3. When the Status field Indicates that the USB drive has been detected, press the “Download Configuration from Instrument” Start button.
4. When the Status field Indicates that the download is complete, remove the flash drive.
5. In the target instrument, go to the Home>Utilities>USB Utilities>General page.
6. Insert a flash drive into either of the two front panel USB ports.
7. When the Status field Indicates that the USB drive has been detected, press the “Upload Configuration to Instrument” Start button.
8. When the Status field Indicates that the upload is complete, remove the flash drive.

3. COMMUNICATIONS AND REMOTE OPERATION

This instrument's rear panel connections include an Ethernet port and a serial communications port. Connection instructions were provided in Section 2.3.1.4. Configuration information was provided in Section 2.5.10.

Data acquisition is set up through the Datalogger (Section 2.5.1).

3.1. SERIAL COMMUNICATION

The rear panel COM port operates on the RS-232 protocol (default configuration is DCE RS-232), or it can be configured for DTE RS-232 (Section 2.3.1.4).

Referring to Table 2-12, use the SETUP>COMM menu to view/edit the communications settings for the COM port.

3.1.1. MODBUS

MODBUS communications can be configured through the Setup>Comm>COM2 menu for transmission over Ethernet (Section 3.2) or serial communications.

1. Make the appropriate cable connections between the instrument and a PC.
2. Check the instrument's Modbus Units selection in the Setup>Vars menu and edit if needed.
3. Select the communication protocol for either MODBUS RTU or MODBUS ASCII transmission mode.

Important

When using MODBUS RTU, ensure that the Handshaking Mode is set to either Hardware or OFF. Do NOT set it to Software.

4. Set other parameters as needed (see descriptions in Table 2-12).
5. Press the Accept button to apply the settings.

The Setup>Comm>TCP Port2 is set to 502 for MODBUS by default.

See Appendix A for MODBUS Registers.

3.1.2. HESSEN

Hessen protocol is supported through serial communications. The Hessen protocol is not strictly defined; therefore, while Teledyne API's application is completely compatible with the protocol itself, it may be different from implementations by other companies. Configure the COM2 port for Hessen protocol through the Setup>Comm>COM2 menu: select COM2 Protocol and press Edit to select HESSEN, then press Accept.

Hessen configuration includes settings for alarms, version, response mode, status flags and gas list. Locate the alarms in the Hessen Settings list (Setup>Comm>Hessen>Hessen Settings) and edit as desired.

HESSEN RESPONSE MODE

Set the response mode, referring to Table 3-1 for descriptions.

Table 3-1. Teledyne API's Hessen Protocol Response Modes

MODE ID	MODE DESCRIPTION
CMD	This is the default setting. Responses from the instrument are encoded as the traditional command format. Style and format of responses depend on exact coding of the initiating command.
BCC	Responses from the instrument are always delimited with <STX> (at the beginning of the response, <ETX> (at the end of the response followed by a 2 digit Block Check Code (checksum), regardless of the command encoding.
TEXT	Responses from the instrument are always delimited with <CR> at the beginning and the end of the string, regardless of the command encoding.

HESSEN VARIATION

For the Hessen Variation setting, there are two versions.

- TYPE 1 is the original implementation.
- TYPE 2 has more flexibility when operating with instruments that can measure more than one type of gas. For more specific information about the difference between the two versions, download the *Manual Addendum for Hessen Protocol* from the Teledyne API's web site.

HESSEN STATUS FLAGS

Locate the various status flags in the Hessen Settings list and edit as needed. They are listed by status flag name with their default bit assignments. (Those with unassigned flags are listed as "0x0000").

- The status bits are included in the instrument's responses to inform the host computer of its condition. Each bit can be assigned to one operational and warning message flag.
- It is possible to assign more than one flag to the same Hessen status bit. This allows the grouping of similar flags, such as all temperature warnings, under the same status bit.
- Assigning conflicting flags to the same bit will cause each status bit to be triggered if any of the assigned flags is active.

HESSEN LIST

Table 3-2 describes the Hessen List (Setup>Comm>Hessen menu).

Table 3-2. Hessen List Configuration Summary

ITEM	DEFINITION
Parameter	gas or non-gas parameter: either Add new or Edit existing
Range	concentration range to be reported (when Reported box is checked)
0	currently active range
1	only when range 1 or low range is active
2	only when range 2 or high range is active
3	not applicable
Id	unique identification for parameter being added or edited
Reported	Check to report when polled by the Hessen network

3.2. ETHERNET

When using the Ethernet interface, the analyzer can be connected to any Ethernet network via low-cost network hubs, switches or routers. The interface operates as a standard TCP/IP device on port 3000. This allows a remote computer to connect through the network to the analyzer using NumaView™ Remote, terminal emulators or other programs.

The Ethernet connector has two LEDs that are on the connector itself, indicating its current operating status.

Table 3-3. Ethernet Status Indicators

LED	FUNCTION
green (link)	On when connection to the LAN is valid.
amber (activity)	Flickers during any activity on the LAN.

The analyzer is shipped with DHCP enabled by default. This allows the instrument to be connected to a network or router with a DHCP server; however, it should be configured with a Static IP address as soon as practical. See Section 2.5.10.4 for configuration details.

For MODBUS communications configuration, see Section 3.1.1.

3.3. NUMAVIEW™ REMOTE

For remote operation and data capture through an Ethernet connection, please refer to the NumaView™ Remote Software User Guide, PN 08492, available on our website.

4. CALIBRATION

This section is organized into subsections as follows:

SECTION 4.1 – Important Precalibration Information: contains important information you should know before calibrating the instrument.

SECTION 4.2 – Calibration Procedures: describes the procedure for manually checking calibration and performing actual calibration of the instrument.

SECTION 4.3 – Automatic Span Cal Check (Auto Cal): describes the procedure for using the AutoCal feature to check calibration or to calibrate the instrument. (The AutoCal feature requires that the span cal valve option be installed and operating).

SECTION 4.4 - Linearity Calibration: linearizes chromatogram using dilution and flow inputs.

4.1. IMPORTANT PRECALIBRATION INFORMATION

Note

A start-up period of 1-2 hours is recommended prior to calibrating the analyzer.

4.1.1. CALIBRATION REQUIREMENTS

Note

Zero air and span gases must be supplied at least at a 1 LPM gas flow rate.

The following equipment, supplies, and expendables are required for calibration:

- Zero air supply Zero Air Generator (i.e. T701H) or Zero Air Cylinder (with purity and pressure spec)
- Span gas source (Recommended BTEX cylinder mixture with balance, including concentrations and pressure)
- Carrier gas source (Recommended with purity and pressure spec)
- Auxiliary air (Air type and pressure spec)
- Gas lines - all sample and calibration gas line materials should be stainless steel or Teflon-type (PTFE or FEP).

Optional equipment:

- Calibrator (e.g., T700)
- Recording device such as a strip-chart recorder and/or data logger

For electronic documentation, the internal data acquisition system (DAS) can be used by configuring the Datalogger through the Setup>Data Logging menu; Section 2.5.1).

The method for performing an initial calibration for the analyzer differs between the standard instrument and those with options.

- See Section 4.2.1 for instructions for initial calibration of the analyzer in its base configuration.
- See Section 4.2.2 for information regarding setup and calibration of the analyzer with the Span Calibration Valve option.

4.1.2. CALIBRATION (SPAN) GAS

The span gas should be comprised of the five gases at either 80% of the range or can be diluted to 80% of the range.

4.1.3. DATA RECORDING DEVICES

A strip chart recorder, data acquisition system or digital data acquisition system should be used to record data from either the Ethernet, serial or analog outputs.

- If analog readings are used, the response of the recording system should be checked against a NIST traceable voltage source or meter.
- Data recording devices should be capable of bi-polar operation so that negative readings can be recorded.

For electronic data recording, the analyzers provide an internal data logger, which is configured through the Setup>Data Logger menu (Section 2.5.1).

NumaView™ Remote (Section 3.3) is a remote control program, which is also available as a convenient and powerful tool for data viewing and handling, download, storage, quick check and plotting.

4.2. CALIBRATION PROCEDURES

Check that the pneumatic connections for the specific instrument configuration are as instructed in Section 2.3.2.

To calibrate or to perform a calibration check for basic configuration instruments, see Section 4.2.1.

To calibrate or to perform a calibration check for instruments with the span cal valve option, see Section 4.2.2.

4.2.1. CALIBRATION AND CHECK PROCEDURES FOR BASIC CONFIGURATION

Although this section uses the Calibration menu for both calibration check and actual calibration, a check does not require the Calibration menu. Instead, while in Home page, simply flow the zero air or the span gas through the Sample port and check the reading after about 30minutes (either in the gas graph or in the Dashboard).

Otherwise, use the procedures presented in the following sections: either Section 4.2.1.1 for a blended cylinder of all five gases or Section 4.2.1.2 for individual cylinders.

Note

The gas values will not immediately be updated to the new calibrated concentrations until after the completion of a full measurement cycle following the span adjustment.

4.2.1.1. CALIBRATION WITH BLENDED CYLINDER

1. Start sampling the Blend sample with 80% of the target range, allowing it to run at least 30 minutes to help improve calibration accuracy.
2. In the Calibration > Span Cal and press the Start button.
3. Click the “Set Span Target” button.
4. In the Span Target page, check the gas boxes.
5. For each gas concentration, click the blue button, input the target gas value, and click Enter.
6. Do this for all five concentrations, then click Done.
7. Click Span to start the calibration process.
8. Click Stop when ready to stop calibrating and return to Measurement Mode.

4.2.1.2. CALIBRATION OF INDIVIDUAL GAS CYLINDER

1. In the Calibration>Span Cal menu, input Span gas through the Sample port, allowing it to run for at least 30 minutes to help improve calibration accuracy, then press the Start button.
2. Click the “Set Span Target” button.
3. In the Span Target page, check the box for the [gas] being calibrated and uncheck the others,
4. Click the blue button in the [gas] field to input the concentration of gas being delivered to the instrument and click Enter when complete.
5. Click Done to return to the Span Cal page.
6. Click the Span button to complete the calibration
7. Click Stop when ready to stop calibrating and return to Measurement Mode.

4.2.2. CALIBRATION AND CHECK PROCEDURES WITH SPAN CAL VALVE AND DIGITAL EXPANSION BOARD OPTIONS INSTALLED

Digital inputs are available for controlling calibration checks when the Digital I/O Expansion Board option is installed. Instructions for setup and use of this board option are in Section 2.3.1.3.

When the Digital Inputs are activated for at least 5 seconds, the instrument switches into high span mode and the internal cal valve will be automatically switched to the appropriate configuration.

- The remote calibration Digital Inputs may be activated in any order.
- It is recommended that the Digital Inputs remain closed for at least 10 minutes to establish a reliable reading.
- The instrument will stay in the selected mode for as long as the Input remains closed.

If Digital Inputs are being used in conjunction with the analyzer’s AutoCal (see Section 4.3) feature, and the AutoCal attribute “Enabled” box is checked, the analyzer will check the span calibration when n Input is opened; then the check value will be recorded and the instrument will return to Measuring mode.

If the AutoCal attribute “Enabled” box is unchecked, the instrument will return to Measuring mode without checking the span calibration.

4.3. AUTOMATIC SPAN CAL CHECK (AUTO CAL)

The Auto Cal feature allows unattended periodic operation of the Span Cal Valve option by using the instrument’s internal time of day clock. Auto Cal operates by executing preprogrammed span calibration checks set up by the user to open and close the valve appropriately. It is possible to set up and run up to three separate preprogrammed calibration checks (labeled # 1, 2 and 3).

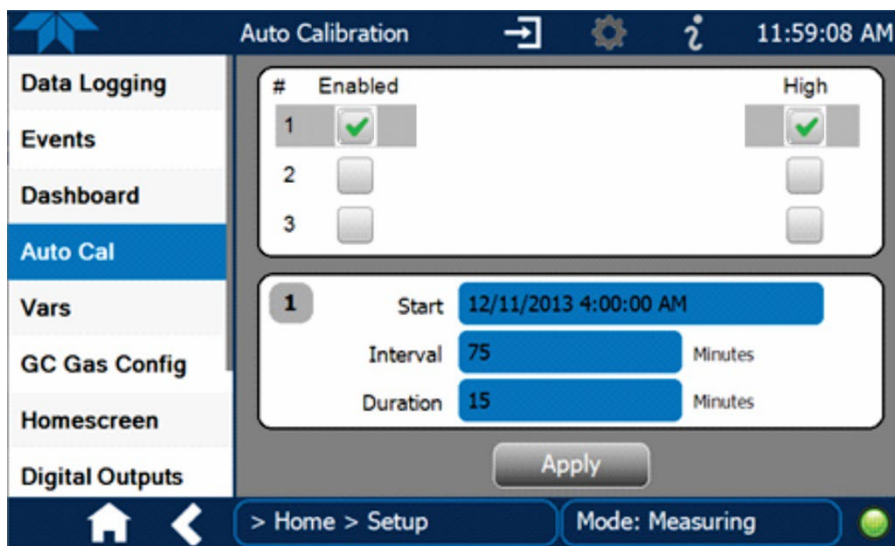

Figure 4-1. Auto Cal Page

There are four parameters that control operational details: Date, Time (both in the Start field), Interval, and Duration, as presented in Table 4-1.

Table 4-1. Auto Cal Programming Sequence Execution

ATTRIBUTE	ACTION
Start	When the Enabled box is "on" <input checked="" type="checkbox"/> , the Sequence (identified by its number) begins on the date and time shown in the configurable Start field. (Click the field for the pop-up window and toggle between the Time (Hour/Minutes) and the Date (Year/Month/Day) attributes to edit as needed).
Interval	Number of minutes to skip between each Sequence execution. (Click the field to input the number of minutes in the pop-up window).
Duration	Number of minutes that each Sequence execution is to run. (Click the field to input the number of minutes in the pop-up window).

Important

IMPACT ON READINGS OR DATA

- **The programmed STARTING_TIME must be a minimum of 5 minutes later than the real time clock. (For setting real time clock, see Setup>Instrument, Section 2.5.8).**
- **Avoid setting two or more span cal checks at the same time of the day.**
- **Any new span cal check that is initiated, whether from a timer, the COM ports or the contact closure inputs, will override any sequence that is in progress.**

4.4. LINEARITY CALIBRATION

The linearity is calibrated at the factory. However, if there is a need to remove or add points (maximum 7) then navigate to the Utilities>Linearize menu. In case range is changed or linearity checks fail, then proceed with a linearity calibration.

4.4.1. CYL GAS CONFIG

In the Cyl Gas Config menu, set the concentration of each gas that's in the cylinder, using PPT only. (Click the blue value button for each gas to edit).

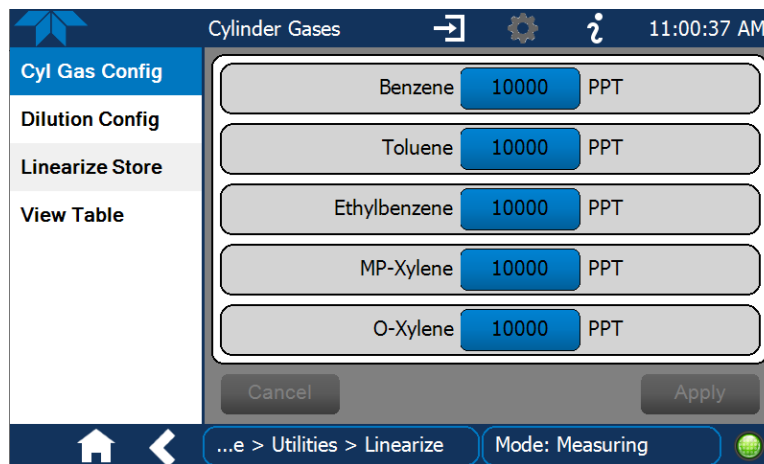

Figure 4-2. Linearize Menu, Cylinder Gas Configuration

4.4.2. DILUTION CONFIG

Press Start to set the Dilution Flow and the Source Gas Flow rates for each linearization point with values from the calibrator.

From the dilution system providing the calibration gas to the analyzer, enter the Dilution Flow and the Source Gas Flow. The N904 will then calculate the resulting diluted value for each gas based on these flows and the cylinder concentrations defined under Cyl Gas Config.

For each Linearity point, input the lowest concentration in LIN 1 to highest concentration in last LIN 5, evenly distributing the values across the expected measurement range. (refer to the Concentrations page in Figure 4-5 for example). When complete, press Stop.

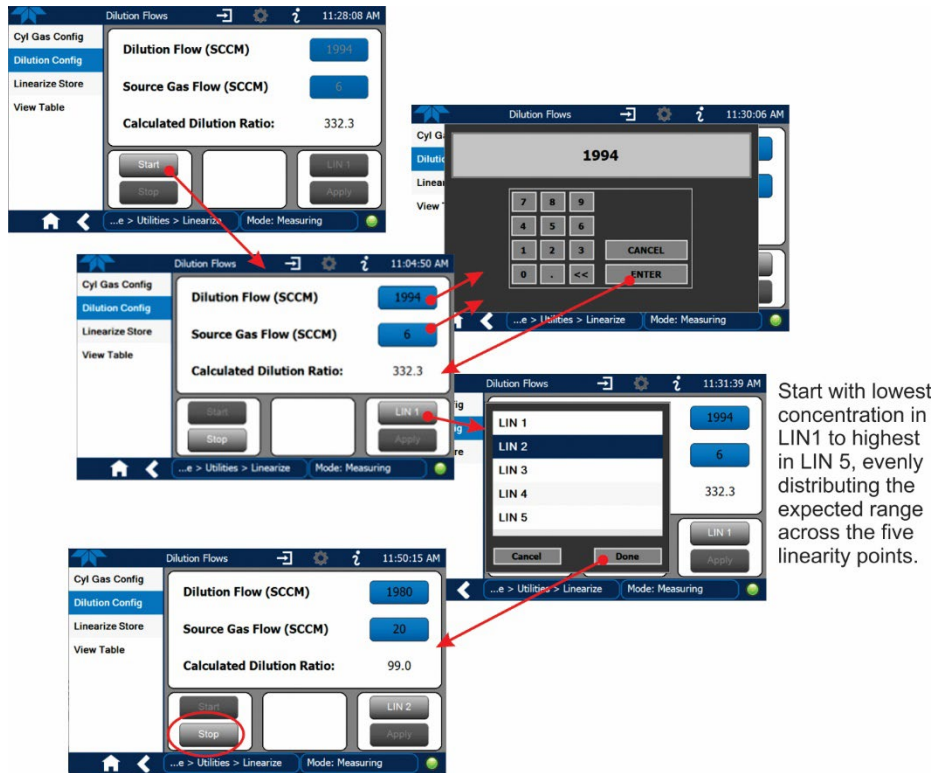

Figure 4-3. Linearize Menu, Dilution Configuration

4.4.3. LINEARIZE STORE

Gases must be present and stabilized in instrument while performing each point. Ensure the analyzer is sampling the gas concentration that matches the selected linearity point, and then in the Linearize Store menu press the Start button to activate the linearity calibration.

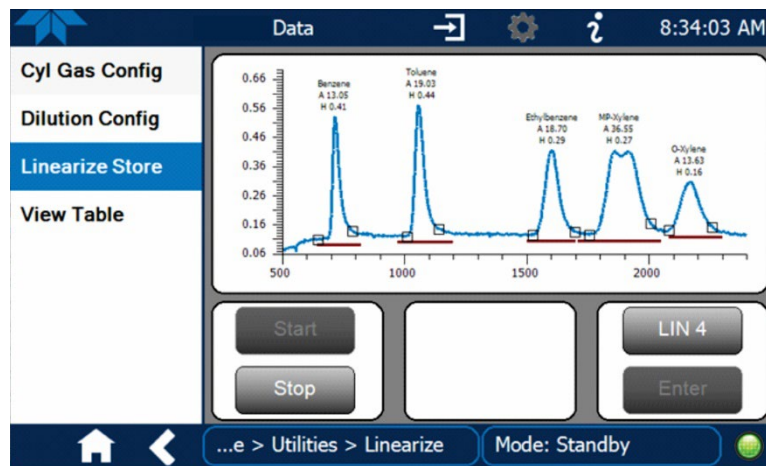
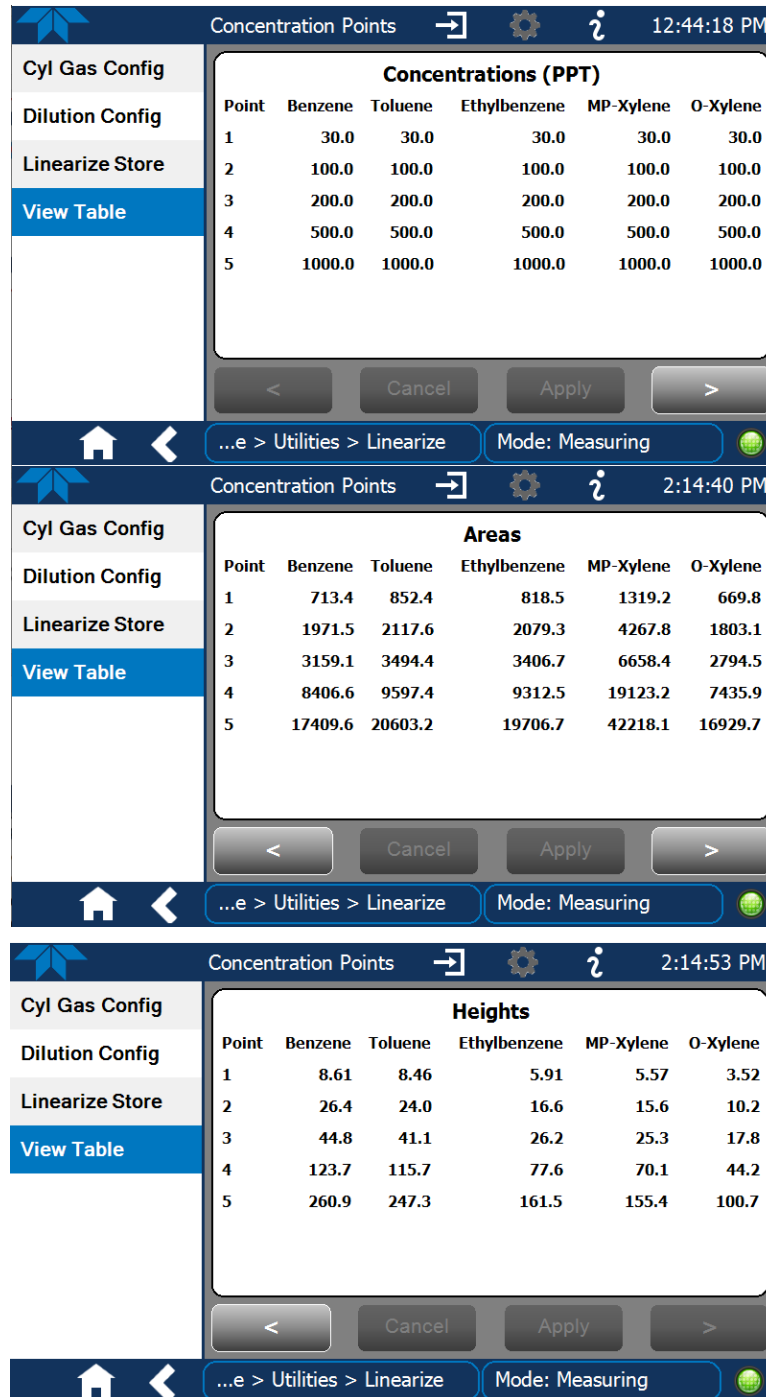

Figure 4-4. Linearize Menu, Linearize Store

4.4.4. VIEW TABLE

In this menu there are three pages to view: the Concentrations for each linearity point that were input through the Dilution Config menu and their corresponding Areas and Heights.



The figure displays three sequential screenshots of the 'Linearize' menu's 'View Table' pages. Each screenshot shows a table with 5 points and 6 columns (Benzene, Toluene, Ethylbenzene, MP-Xylene, O-Xylene). The top navigation bar includes 'Concentration Points', a home icon, a back arrow, a settings gear, an info icon, and the time. The bottom navigation bar includes a home icon, a back arrow, a breadcrumb trail ('...e > Utilities > Linearize'), a 'Mode: Measuring' indicator, and a globe icon.

Concentration Points (PPT)

Point	Benzene	Toluene	Ethylbenzene	MP-Xylene	O-Xylene
1	30.0	30.0	30.0	30.0	30.0
2	100.0	100.0	100.0	100.0	100.0
3	200.0	200.0	200.0	200.0	200.0
4	500.0	500.0	500.0	500.0	500.0
5	1000.0	1000.0	1000.0	1000.0	1000.0

Areas

Point	Benzene	Toluene	Ethylbenzene	MP-Xylene	O-Xylene
1	713.4	852.4	818.5	1319.2	669.8
2	1971.5	2117.6	2079.3	4267.8	1803.1
3	3159.1	3494.4	3406.7	6658.4	2794.5
4	8406.6	9597.4	9312.5	19123.2	7435.9
5	17409.6	20603.2	19706.7	42218.1	16929.7

Heights

Point	Benzene	Toluene	Ethylbenzene	MP-Xylene	O-Xylene
1	8.61	8.46	5.91	5.57	3.52
2	26.4	24.0	16.6	15.6	10.2
3	44.8	41.1	26.2	25.3	17.8
4	123.7	115.7	77.6	70.1	44.2
5	260.9	247.3	161.5	155.4	100.7

Figure 4-5. Linearize Menu: View Table Pages for Concentrations, Areas, and Heights

4.5. HIGH CONCENTRATION APPLICATIONS AND CALIBRATION

While the default factory settings are intended to achieve low limitations for ambient applications, other applications may require higher range settings. Due to the nature of the application, this can be somewhat of a trial-and-error process.

To raise the range, first sample the new high concentration target and check the chromatogram displayed on the Calibration page.

- If all peaks are fully showing on the screen, then complete the process by running a linear calibration (Section 4.4).
- If any peaks do not fully appear, then navigate to the VARS>DC Pump Fill Time menu and decrease the setting (180 seconds is the default or standard duration). Check the chromatogram on the Calibration page again for the next run. As needed, keep reducing the DC Pump Fill Time Var value setting until the peaks appear as needed, then run a linearity calibration (Section 4.4).

5. MAINTENANCE AND SERVICE

Although this instrument requires little service, a few simple procedures can be performed to ensure that it continues to operate accurately and reliably over its lifetime. In general, the exterior can be wiped down with a lightly damp cloth. Service and troubleshooting are covered in Section 5.5.

ATTENTION

COULD DAMAGE INSTRUMENT AND VOID WARRANTY
Avoid spraying anything directly onto any part of the analyzer.

5.1. MAINTENANCE SCHEDULE

Most maintenance can be carried out on an as-needed basis; the actual frequency can vary depending on the operating environment, such as filter replacement. See Section 5.5.8 for items to service. Use Table 5-1 (or similar form) to track which service was performed when. Keep in mind that in some cases, there may be local regulations or standards that also need to be considered.



WARNING – ELECTRICAL SHOCK HAZARD

Disconnect power before performing any of the following operations that require entry into the interior of the analyzer.



CAUTION – QUALIFIED PERSONNEL

These maintenance procedures must be performed by qualified technicians only.

Important

IMPACT ON READINGS OR DATA

A span calibration check can be performed following maintenance procedures. To perform a CHECK of the instrument's Span Calibration, refer to Section 4.2.2.

DO NOT press the Span button at the end of each operation (actual calibration), as this will reset the stored values for OFFSET and SLOPE and alter the instrument's calibration.

Alternatively, use the Auto Cal feature described in Section 4.3 to run a span calibration check.

Table 5-1. Maintenance Schedule

ITEM	ACTION	FREQ	CAL CHECK DONE? (Y/N)	DATE PERFORMED													
Filter (Section 5.5.8.1)	replace	as needed															
UV Lamp (Section 5.5.8.3)	Clean	Quarterly															
	Replace	As needed															
DC pump (Section 5.5.8.5)	Rebuild or replace	As needed															
PID Ion Chamber (Section 5.5.8.4)	Clean	Annually or As needed															

5.2. OPERATIONAL HEALTH CHECKS

Navigate to the Utilities>USB Utilities>Report menu (Figure 5-1) to download a report on the basic operations of the instrument. To download the report for your own viewing on a computer or to send to others, insert a flash drive into a front panel USB port and press the Download button, which is enabled when the instrument detects the flash drive.

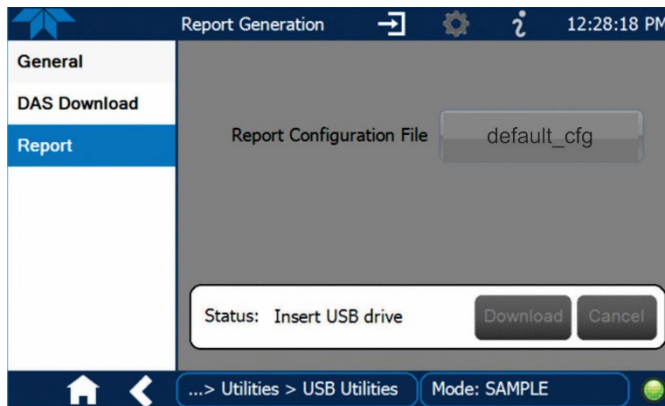

Figure 5-1: Report Generation Page

The report can also be set to generate periodically and sent to a Web services “cloud” where it is available for viewing by Teledyne API technical support personnel. Set this function with two Vars:

Setup>Vars>Upload Report to Cloud: set to True.

Setup>Vars>Report Upload>Interval: edit the number of hours between report uploads.

5.3. SOFTWARE/FIRMWARE UPDATES

There are two ways to check for and acquire updates: either remotely or manually.

5.3.1. REMOTE UPDATES

The instrument must be connected to a network that is connected to the Internet. In the Setup>Instrument menu, select the Remote Update menu and press the Check for Updates button. If an update is available, it can be downloaded through this page, or it can be done remotely (Section 5.3.2).

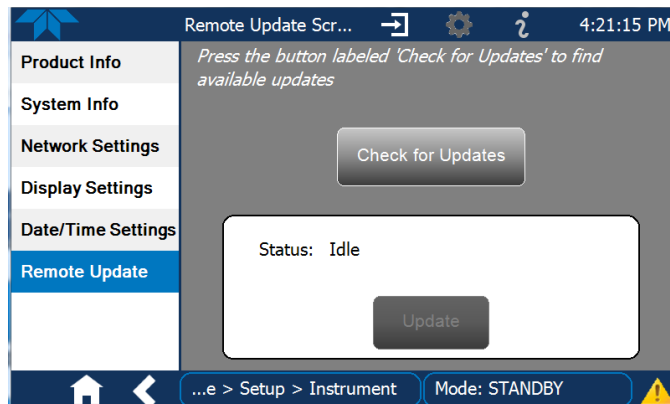

Figure 5-2. Remote Update Page

5.3.2. MANUAL RELOAD/UPDATE PROCEDURES

To reload or update firmware, first contact Technical Support to obtain the applicable file(s): api-techsupport@teledyne.com /+1 800-324-5190.

1. Follow Technical Support's instructions for copying the firmware files to a flash drive.
2. Go to the Utilities>USB Utilities>General menu.

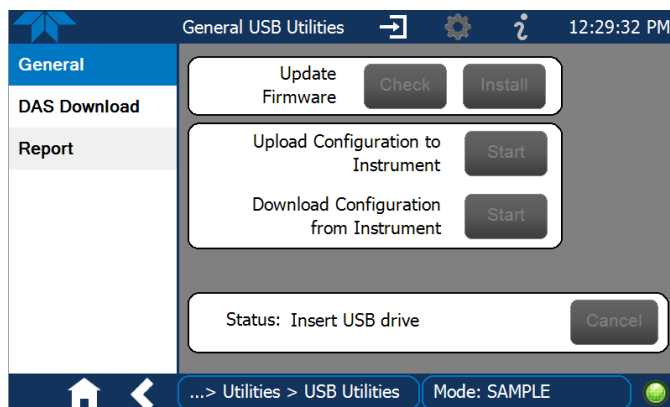

Figure 5-3. Manual Update Page (and other utilities)



3. Insert a flash drive into a front panel USB port and wait for the Status field to indicate that the drive has been detected.
4. In the Update Firmware field, press the Check button for the instrument to determine whether the firmware on the flash drive is more recent than what is currently installed. Once it's been determined that the firmware is new, the Install button will be enabled; if the firmware version on the flash drive is the same as or older than the current firmware of the instrument, the Install button will not be enabled.
5. Press the Install button and note the messages in the Status field at the bottom of the page. Use the Cancel button if necessary.
6. When complete, as indicated in the Status field, press the Done button, which replaces the Cancel button, and remove the flash drive.
7. Power off and restart the instrument to complete the new firmware installation.

5.4. TIME ZONE CHANGES

There is an option to change between 12-hour and 24-hour format in the Setup>Vars menu (System Time Format). Effectively changing the Time Zone requires a specific procedure as follows:

1. In Setup>Instrument>Date/Time Settings select the applicable Time Zone.
2. Allow adequate time for the selected Time Zone to be properly accepted.
3. Verify: return to Home page then back to the Date/Time Settings page and check that the selected Time Zone is now highlighted.
4. Without making any other changes, power OFF the instrument and power ON again.
5. Once restarted, return to the Date/Time Settings page where the newly selected Time Zone should be highlighted. (If not, it means that not enough time had passed for the instrument to accept the change before the power was cycled OFF).
6. After the Time Zone is implemented first (Steps 1 through 5), then other changes to the date and/or time can be made, and recycling the power is not necessary.

- ① Time zone change must be set **first**.
- ② **Wait**. Allow sufficient time to accept new Time Zone.
- ③ **Verify**. Return to Home page, then return to Date/Time Settings page.
- ④ After correct Time Zone is displayed, **power recycle** the instrument.
- ⑤ Only after Time Zone is selected and instrument rebooted, can other changes to date and/or time be made effectively.

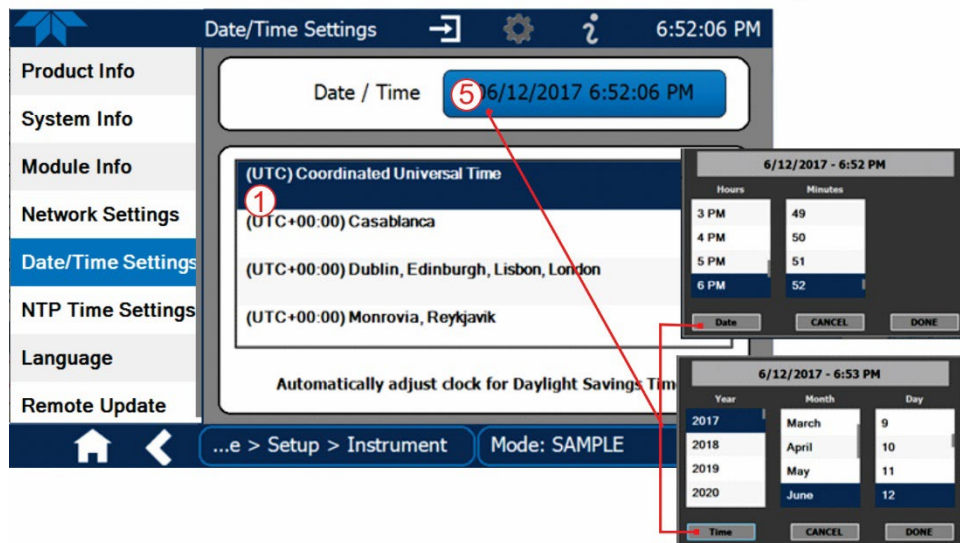

Changes to date and/or time do **not** require a reboot.

Figure . Time Zone Change Requirements

5.5. SERVICE AND TROUBLESHOOTING

This section contains methods to identify the source of performance problems with the analyzer and procedures to service the instrument.



CAUTION

The operations outlined in this section must be performed by qualified maintenance personnel only.



WARNING – RISK OF ELECTRICAL SHOCK

Some operations need to be carried out with the analyzer open and running.

Exercise caution to avoid electrical shocks and electrostatic or mechanical damage to the analyzer.

Do not drop tools into the analyzer or leave them after your procedures.

Do not short or touch electric connections with metallic tools while operating inside the analyzer.

Use common sense when operating inside a running analyzer.



CAUTION!

Use a low level, handheld H₂ leak detector, such as the Restek Electronic Leak Detector, to check for H₂ leaks any time the unit is opened for service, including at the cylinder regulator when a cylinder is replaced, and around the external connections any time they are disconnected.

If the presence of Hydrogen gas is detected at any time, power down the instrument and contact Teledyne API Technical Support as soon as possible:

+1 800-324-5190 or email: api-techsupport@teledyne.com

The analyzer has been designed so that problems can be rapidly detected, evaluated and repaired. During operation, it continuously performs diagnostic tests and provides the ability to evaluate its key operating parameters without disturbing monitoring operations.

A systematic approach to troubleshooting will generally consist of:

- noting any Alerts and taking corrective action as necessary.
- examining the values of all basic functions in the Dashboard and comparing them to factory values, taking corrective action for any major deviations from the factory values.
- checking the internal electronic status LEDs to determine proper operation/functionality (see Figure 5-4 and Figure 5-5).

5.5.1. FAULT DIAGNOSIS WITH ALERTS

Some warning Alerts may occur during start up and typically resolve on their own.

It should be noted that if more than two or three warning Alerts occur at the same time, it is often an indication that some fundamental sub-system has failed rather than an indication of the specific failures referenced by the Alerts.

In addition to being useful as predictive diagnostic tools, the functions viewable in the Dashboard can be used to isolate and identify many operational problems.

The acceptable ranges for these functions are listed in the “Nominal Range” column of the analyzer *Final Test and Validation Data Sheet* shipped with the instrument. Values outside these acceptable ranges indicates a failure of one or more of the analyzer’s subsystems. Functions whose values are still within acceptable ranges but have significantly changed from the measurement recorded on the factory data sheet may also indicate a failure.

Make note of these values for reference in troubleshooting.

5.5.2. USING THE DIAGNOSTIC SIGNAL I/O FUNCTIONS

The signal I/O functions in the Utilities>Diagnostics menu allows access to the digital and analog I/O in the analyzer. Some of the digital signals can be controlled through the Setup menu. These signals are useful for troubleshooting in three ways:

- The technician can view the raw, unprocessed signal level of the analyzer’s critical inputs and outputs.
- Some components and functions that are normally under algorithmic control of the CPU can be manually exercised.
- The technician can directly control the signal level Analog and Digital Output signals.

This allows the technician to observe systematically the effect of directly controlling these signals on the operation of the analyzer. Use the Utilities>Diagnostics menu to view the raw voltage of an input signal or the Setup menu to control the state of an output voltage or control signal.

5.5.3. FAULT DIAGNOSIS WITH LEDS

The following illustrations show connectors and LEDs that can indicate where issues may lie. Figure 5-4 shows the layout for the mainboard.

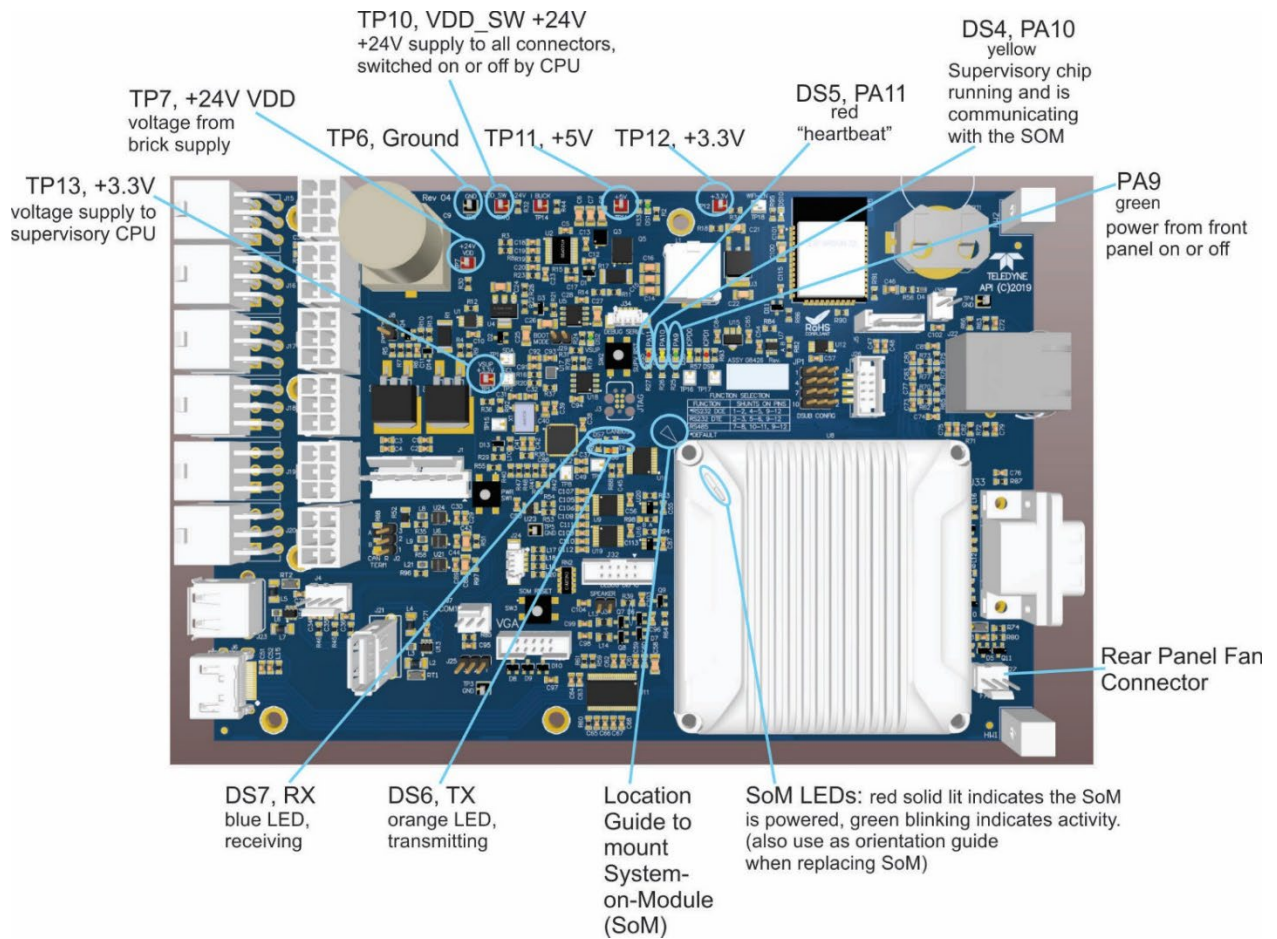

Figure 5-4. Mainboard

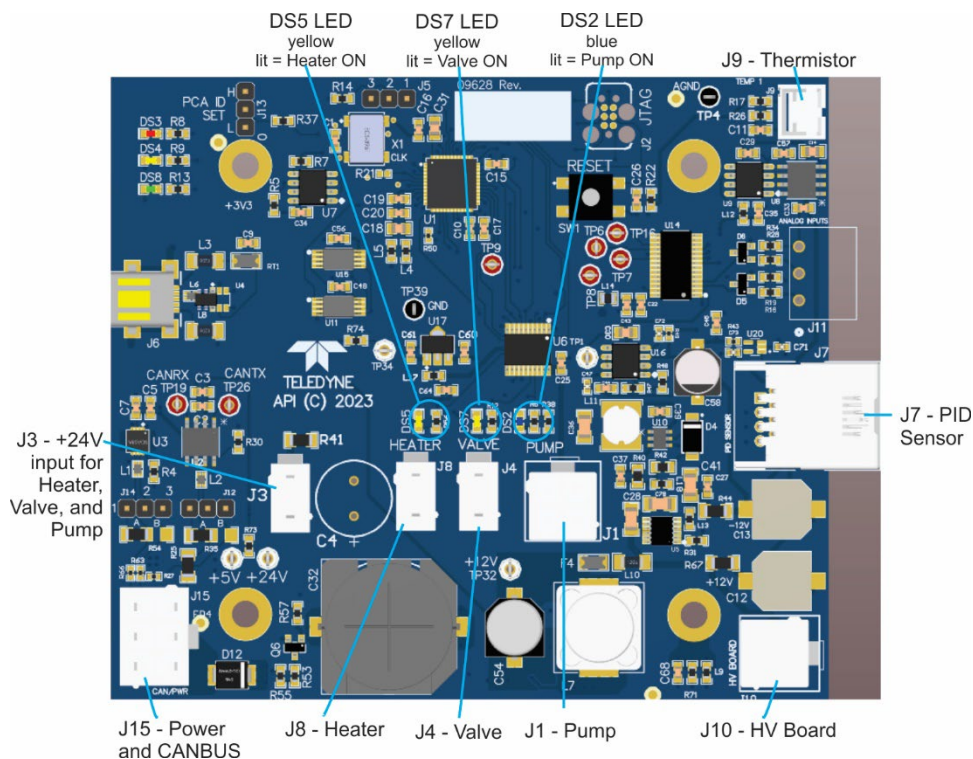

Figure 5-5. PID Sensor Board

5.5.4. CALIBRATION PROBLEMS

This section describes possible causes of calibration problems.

5.5.4.1. ABSENCE OF ANALYZER RESPONSE TO SAMPLE GAS

If the instrument shows no response (display value is near zero) even though sample gas is supplied properly and the instrument seems to perform correctly:

1. Confirm the lack of response by supplying span gas of about 80% of the range value to the analyzer.
2. Check if pump is running at the beginning of each run, either by sound of pump or by connecting a flow meter on SAMPLE IN port.
3. Check for disconnected cables to the sensor module.
4. Check if light appears from top of the PID. If not on, see Section 5.5.8.3.

5.5.4.2. UNSTABLE ZERO AND SPAN

Contamination on the sample line would be the most common source of unstable and non-repeatable concentration readings.

1. Sampling lines could be contaminated; this can be remedied by “cleaning” with nitrogen (run nitrogen through the tubing); if that doesn’t work, replace the tubing.

2. If incorrect reading persists, then it could be the sample filter; in that case, contact Technical Support for guidance.
3. If calibration connections in place, consider pneumatic components in the gas delivery system outside the analyzer such as a change in zero air source (ambient air leaking into zero air line) or a change in the span gas concentration due to zero air or ambient air leaking into the span gas line.

5.5.4.3. INABILITY TO SPAN - DEACTIVATED SPAN BUTTON

In general, the analyzer will deactivate certain buttons whenever the actual value of a parameter is outside of the expected range for that parameter. If the Span is grayed out, the actual concentration could be outside of the range of the expected span gas concentration, or if peak is missing from the chromatogram, then either there is no flow or a gas is missing.

1. Verify that the expected concentration is set properly to the actual span gas concentration in the CONC sub-menu.
2. Confirm that the span gas source is accurate.
 - This can be done by comparing the source with another calibrated analyzer.
3. If missing gas peak, check flow.

5.5.5. GC STATUS “NOT READY”

If after a reasonable 30-60-minute warmup period, the GC Status tag still shows “Not Ready,” then refer to the following troubleshooting guide:

GC Status Reading	Instrument Mode	Action
Not Ready	Startup	Wait for the unit to finish its warm-up period so that the gas pressure and temperatures reach their setpoint values. The unit will begin running automatically after all pressure and temperature parameters reach their respective set points.
Not Ready	Standby	Check: <ul style="list-style-type: none"> - Carrier Pressure - Column Temperature - PreCon Temperature - Injector oven temperature
Ready	Standby	In the VARs menu change the Exit Standby mode to TRUE . If the unit returns to Standby Mode, then check: <ul style="list-style-type: none"> - PID temperature

5.5.6. SLOW RESPONSE

If the analyzer starts responding too slowly to any changes in sample or span gas, check for the following:

- Dirty or plugged sample filter or sample lines.
- Sample inlet line is too long.
- Wrong materials in contact with sample - use stainless steel or Teflon materials only.
- Insufficient time for purging lines upstream of the analyzer. Wait for stability is reached.
- Insufficient time for calibration gas source to stabilize. Wait until stability is reached.
- Pump not working properly

5.5.7. SUBSYSTEM CHECK FOR TROUBLESHOOTING

The preceding sections of this manual discussed a variety of methods for identifying possible sources of failures or performance problems within the analyzer. This section describes how to determine whether a certain component or subsystem is actually the cause of the problem being investigated.

5.5.7.1. AC MAIN POWER



WARNING – ELECTRICAL SHOCK HAZARD

Should the AC power circuit breaker trip, investigate and correct the condition causing this situation before turning the analyzer back on.

The instrument's electronic systems will operate with any of the specified power within the 100 VAC to 240 VAC, at 47 Hz to 63 Hz. Using the properly rated power cord, it will power on when the rear panel Hard Power switch is placed in the ON position. (If the power source is disrupted, the instrument will return to the state it was in at the time of disruption when power is restored). If the instrument doesn't start, check the following possible causes and possible solutions:

- Check the power cord for damage, such as whether it's cut or burned.
- Check that the power cord is adequately rated for the instrument's specified power rating.
- Check that the power source is of the proper voltage for the instrument's specified power rating.
- If there are no findings in the preceding steps, then note whether the instrument had been opened for maintenance; if so, place the rear panel Hard Power switch in the OFF position, and disconnect the power cord; then reopen the instrument and check that no wiring had been dislodged, and no tools were left inside.
- If no other reason can be found for the instrument not powering on, then check the fuse with an ohmmeter to determine its viability: carefully follow the instructions in Section 5.5.8.1 to remove the fuse for testing.
 - If the fuse is blown, replace it with a fuse of the correct specifications as instructed in Section 5.5.8.1.
- If the fuse is not blown, or if the replacement fuse blows, then call Technical Support (Section 5.6).

5.5.7.2. LCD/DISPLAY MODULE

Assuming that there are no wiring problems and that the DC power supplies are operating properly, the display screen should light and show the splash screen and other indications of its state as the CPU goes through its initialization process.

5.5.7.3. RS-232 COMMUNICATIONS

Teledyne API's analyzers use the RS-232 communications protocol to allow the instrument to be connected to a variety of computer-based equipment. Problems with RS-232 connections usually center around such things as incorrect connector configuration, incorrect software settings, improper/incomplete seating of the internal cable. Do not do anything inside the instrument without first contacting Technical Support (Section 5.6). For additional information, see Section 2.3.1.4 under "Serial Connection."

5.5.8. SERVICE PROCEDURES

This section contains some procedures that may need to be performed when a major component of the analyzer requires repair or replacement.

Note

Regular maintenance procedures are discussed in Section 5.4 and are not listed here). Also, there may be more detailed service notes for some of the below procedures. Contact Teledyne API's Technical Support Department (Section 5.6).



WARNING – ELECTRICAL SHOCK HAZARD

Unless the procedure being performed requires the instrument to be operating, turn it off and disconnect power before opening the analyzer and removing, adjusting or repairing any of its components or subsystems.



CAUTION – QUALIFIED TECHNICIAN

The operations outlined in this chapter are to be performed by qualified maintenance personnel only.

5.5.8.1. FILTER ELEMENT REPLACEMENT

Inspect the particulate filter often for signs of plugging or contamination. It should be replaced according to the service interval schedule even without obvious signs of dirt, as filters with 1 and 5 μm pore size can clog up while retaining a clean look.

Tools/Materials:

- Lint-free gloves
- PTFE-coated tweezers
- Replacement filter

Important

IMPACT ON READINGS OR DATA

Use gloves or PTFE coated tweezers or similar handling to avoid contamination of the sample filter assembly. Do not touch any part of the housing, filter element, PTFE retaining ring, glass cover and the o-ring with bare hands, as contamination can negatively impact accuracy of readings.

To change the filter:

1. Turn OFF the analyzer to prevent drawing debris into the instrument.
2. Open the hinged rear panel and unscrew the Retaining Ring on the filter assembly (Figure 5-6).

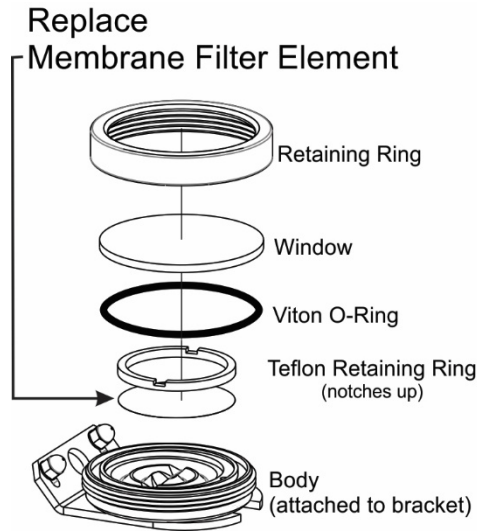

Figure 5-6. Replacing the Particulate Filter

3. Carefully remove the Retaining Ring, the glass Window, the notched Teflon Retaining Ring, and the used Membrane Filter Element. (the Viton O-Ring may come up with the Window or it may remain nested in the Body)
4. Insert the new Membrane Filter Element, being careful that it is fully seated and centered in the bottom of the Body.
5. Ensuring that the Viton O-Ring is nested in the Body, reinsert the Teflon Retaining Ring with the notches up, then the glass Window, and gently screw on the Retaining Ring and hand tighten.
6. Inspect and ensure that the Viton O-ring is creating a proper seal all around.
7. Close the panel and restart the analyzer.



CAUTION – AVOID PERSONAL INJURY

- Do not expose eyes to lamp’s UV light.
- Do not service the lamp without explicit instruction from Teledyne API Technical Support.

5.5.8.2. COLUMN/TRAP MAINTENANCE

A column’s lifetime depends on its environment and its frequency and duration of operation. Because the column and trap temperatures are ramped in every run, there should be no opportunity for buildup of residuals, eliminating the need for routine maintenance.

For hardware failure or other persistent poor performance, contact Technical Support (Section 5.6) for instructions.

5.5.8.3. PID SENSOR LAMP MAINTENANCE OR REPLACEMENT

Cleaning the sensor lamp should be done as part of regular maintenance, every three months. If cleaning does not produce desirable results, the lamp may need to be replaced. If both cleaning and replacement do not produce the desired results, then cleaning the PID Ion Chamber may be necessary before its normal annual maintenance schedule (Section 5.5.8.4).

Important

IMPACT ON READINGS OR DATA

Wear gloves to handle all components of sensor assembly. In addition, use PTFE coated tweezers to remove/replace o-ring.

Tools/Materials:

- Lint-free gloves
- PTFE-coated tweezers
- Lint-free cloth
- Lamp polishing media (paste of [material] from [vendor])
- Deionized or distilled water, heated
- Replacement o-ring if needed per inspection
- Replacement lamp if cleaning does not resolve issue

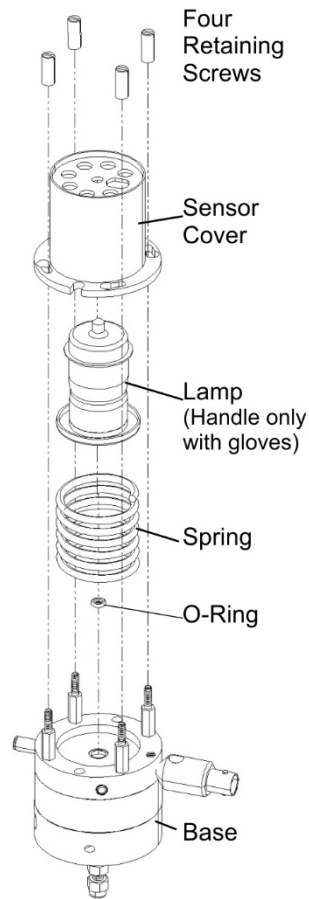

Figure 5-7. PID Sensor Assembly, Lamp Maintenance

Refer to Figure 5-7 for the following procedures;

1. Power OFF the unit.
2. Remove the analyzer's lid.
3. Loosen the four retaining screws.
4. Remove sensor cover by turning counter-clockwise.
5. Remove lamp and spring and set on clean, dry surface.
6. Carefully remove O-ring with coated tweezers and inspect for wear or dirt.
7. If O-ring is worn, replace it; if only dirty, clean with hot water and wipe dry with lint-free cloth.
8. Insert the O-ring snugly into its retaining groove.
9. Separate lamp from spring; if replacing due to previously cleaned lamp not resolving issue, dispose of old lamp and skip to Step 15.
10. Sparingly apply lamp polish media to the lamp's base window.

11. Using a lint-free cloth, carefully polish the window with small circular motions, ensuring that none of the paste gets trapped in the groove between the window and the base plate of the lamp.
12. Holding the lamp with the coated tweezers, rinse the lamp in a bath of very hot water.



CAUTION – AVOID PERSONAL INJURY
Protect fingers/hands from exposure to hot water.

13. If needed, use a soft bristle brush to clean any paste from the groove under hot running water.
14. Taking care to avoid touching the window, dry the lamp with clean, lint-free cloth.
15. Reassemble the spring and lamp (clean or new) and reinstall inside the PID base.
16. Return the sensor cover and tighten the four screws.
17. Secure the analyzer's lid back in place and power ON the unit.

Important

IMPACT ON READINGS OR DATA

For lamp replacement, recalibrate.

For lamp cleaning, calibration should not be necessary, but if a drift persists, a span calibration only should resolve the issue.

Note

It is normal for the chromatogram to show uncommonly extra peaks when running with the new lamp, and should normalize over the first 24 hours of renewed operation.

5.5.8.4. PID ION CHAMBER MAINTENANCE

While this is typically an annual maintenance item, cleaning the PID Ion Chamber may be needed if/when replacing the lamp (Section 5.5.8.3) does not produce desired results. In either case, this delicate procedure requires instruction from our Technical Support Department (Section 5.6).

5.5.8.5. PUMP MAINTENANCE OR REPLACEMENT

The pump typically lasts about one year with regular use, but because the N904 uses the pump for only seconds at a time, it is expected to last longer. Two ways to know whether the pump has failed are if:

- There is no audible sound when the pump should be running at the beginning of each measurement run.
- During sampling, the measurement shows 0 and the chromatogram on the SPAN CAL menu shows a flat line/no peaks.

In either case, look for pump failure. Call Technical Support for rebuilding or replacement instructions.

5.5.8.6. FUSE REPLACEMENT PROCEDURE

ATTENTION

COULD DAMAGE INSTRUMENT AND VOID WARRANTY

Fuses do not typically fail without definite cause. Do not attempt to replace until after all measures to detect the cause of a power failure, per Section 5.5.7.1, have been carried out, including Soft Power switch LED not lit (neither solid nor blinking), but Hard Power switch is in ON position and instrument's power cord properly connected at both ends. If an ohmmeter shows that the fuse is good, or if a new fuse blows, call Technical Support (Section 5.6).



WARNING – ELECTRICAL SHOCK HAZARD

Never pull out fuse drawer without ensuring that the Hard Power switch is in OFF position and power cord disconnected, to ensure there is no power to the instrument before checking/changing fuse.

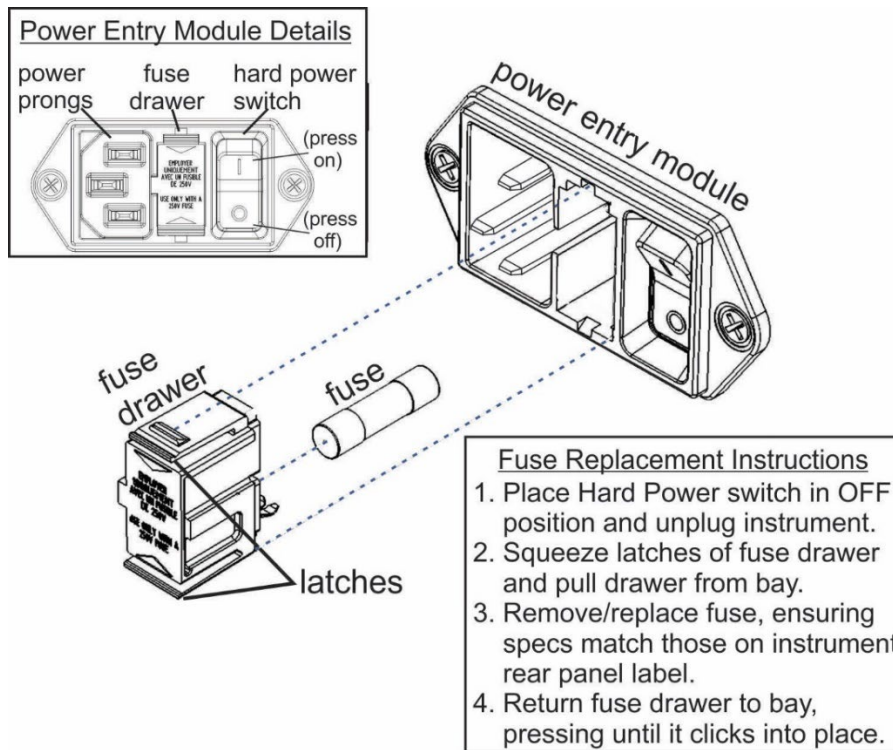

Figure 5-8. Fuse Access



5.6. TECHNICAL ASSISTANCE

For spare parts, or if this manual and its troubleshooting & service section do not solve your problems, technical assistance may be obtained from:

Teledyne API Technical Support
9970 Carroll Canyon Road
San Diego, California 92131-1106 USA

Toll-free Phone: +1 800-324-5190

Phone: +1 858-657-9800

Fax: +1 858-657-9816

Email: api-techsupport@teledyne.com

Website: <http://www.teledyne-api.com/>

6. PRINCIPLES OF OPERATION

The N904 performs Hydrocarbon (HC) analysis by means of Gas Chromatography (GC) with Photo Ionization Detection (PID) to measure benzene, toluene, ethylbenzene, and xylenes, using a preparative method of automatic injection, separation, and fraction collection. A DC pump pulls the sample into the pre-concentrator where it is trapped and heated for thermal desorption. The carrier gas (an inert gas that does not get measured) comprised of 99.999% or UHP-grade Nitrogen (N_2) injects the sample gas from the pre-concentrator into the GC Column that ramps the temperature to separate the gases before outputting to the PID for measurement and recording. The PID produces an ultraviolet (UV) light to create high energy photons (expressed as electron volt, eV) that interact with the sample gas, producing ions that generate a proportionate current, which is then recorded as the gas concentration.

Each measuring cycle then produces a chromatogram (Figure 6-1) consisting of five distinguishable peaks: benzene – to xylene. The instrument’s internal software uses the chromatogram results to calculate the target concentrations using a combination of peak height and peak area integration.

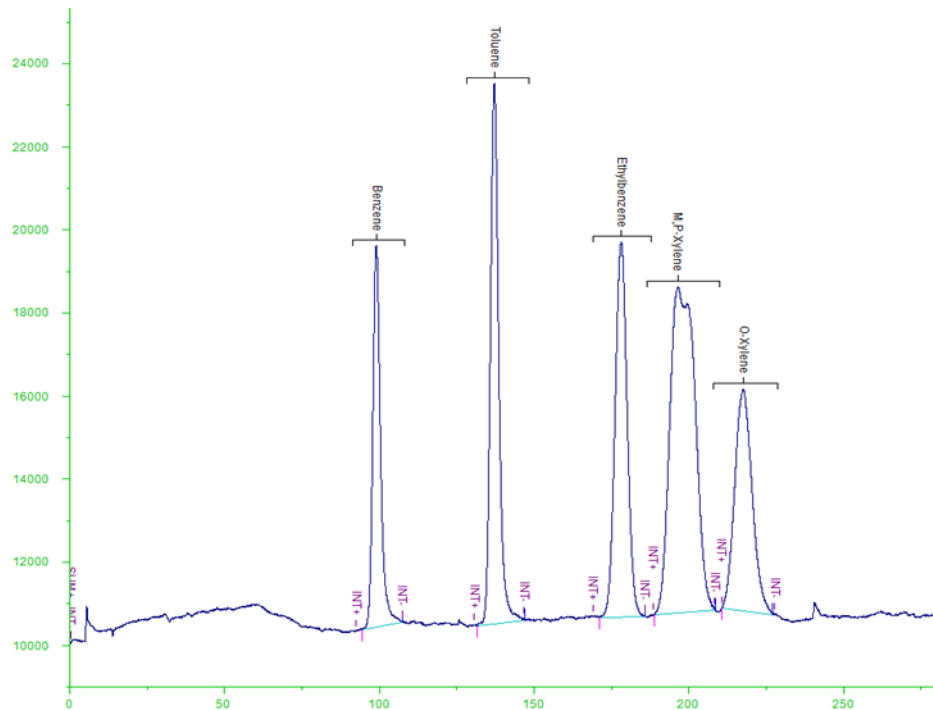

Figure 6-1. Chromatogram Example of Benzene, Toluene, Ethylbenzene, M,P-Xylene, and O-Xylene Peaks

6.1. PNEUMATIC OPERATION

During the Sample Capture phase (refer to the pneumatic diagram, Figure 2-9), an internal DC pump pulls the sample through an internal filter connected to the Sample In port and into the Pre-Concentrator module. The Pre-Concentrator contains high surface adsorbent media to increase the concentration of the sample while it is cold. Then a high-ramp-rate heater takes the column quickly to high temperature and flushes the concentrated sample with the carrier gas into the GC Column. The Pre-Concentrator is cooled rapidly back down in preparation for the subsequent sample.

The carrier gas is an analyte gas that works as a mobile phase to help push the sample and its components into the GC column where the sample members start to separate depending on the variety of its interaction with the column stationary phase. For the most significant separation in the shortest time, the GC Column changes from a cold step for the injection to a hot degree that helps to flush the heavy compounds, then changes back to cold in preparation for the next cycle. The GC Column output goes to the Photo Ionization Detector (PID) where the compound concentration is hit by high-energy photons and broken into positively charged ions, creating a small electrical signal. The PID Amplifier board increases and digitizes the electrical signal.

The remaining sample exits the instrument through either the PID Exhaust or the Sample Exhaust ports.

6.2. ELECTRONIC OPERATION

The electronic platform is based on a Controller Area Network (CAN) bus modular system. CAN is the central networking system that enables communication among all the parts and facilitates centralized diagnoses of errors, as well as configuration of all the parts. CAN bus technology allows for a uniform cable architecture with interchangeable 6-pin connectors configured for power (5 V and 24 V) and communications (CAN high and CAN low serial lines).

The Mainboard is the main hub, which not only contains the Central Processing Unit (CPU) that communicates with other modules, but also directs power and communication distribution. The Mainboard includes an altitude sensor, a temperature sensor, and the Supervisory Chip.

The Supervisory Chip monitors power and the sensors, and when the front panel Soft Power switch is pressed (see Power Switches, Section 6.2.2), the Supervisory Chip directs the soft power down of the internal components, to safely shut down processes and close connections to prevent damage.

6.2.1. MODULES

Each module consists of its own board controlled by a microprocessor that receives messages from and sends information to the Mainboard on the CAN network. Depending on the signal line, CAN Low or CAN High, the modules can determine whether a message is intended for them and what the priority is, and then act on the applicable messages. These are called “Smart Modules,” which conduct local operations, such as activating valves or

controlling manifold temperature. There is also the Sensor Module, which is comprised of the gas sensor and its operational components. The Sensor Module calculates gas concentrations and may command the Smart Modules.

6.2.2. POWER SWITCHES

The front panel Soft Power switch is used to protect the internal components from damage. When the instrument is initially powered on, the Supervisory Chip spins up the internal computer components and places them in operational mode (indicated by LED's solid-lit state). However, before powering off the instrument, pressing and momentarily holding the solid-lit Soft Power switch tells the Supervisory Chip to put the internal computer components through a soft-shutdown process and into deep sleep mode (indicated by LED's blinking state).

The rear panel Hard Power switch is used to turn on or off the instrument, but should not be used to turn off the instrument until first placing it in deep sleep mode as described above. If there is an unexpected loss of source power while the instrument is running, it will power up in the ON state when source power is restored.



N904

APPENDIX A – MODBUS REGISTERS

ADDR	NAME	DESCRIPTION
Discrete Inputs		
0	SYS_WARN_RESET	System has rebooted
1	CARRIER_PRESSURE_WARNING	Carrier pressure out of range
2	COL_TEMP_WARNING	Column temperature out of range
3	OVEN_TEMP_WARNING	Oven temperature out of range
4	INTEG_CFG_WARN	Integration Configuration Warning
5	MEASURE_ABORTED_WARNING	Measurement Aborted
6	GC_DATA_WARNING	GC Data Transfer in process
7	LOW_MEMORY_WARNING	Memory is running low
8	PID_HEATER_TEMP_WARN	PID Heater Temperature out of range
9	PUMP_RUN	Pump Control status
10	SAMPLE_THREE_WAY_VALVE	Sample Three Way Valve status
11	SWITCH_VLV_STAT	Switch valve status
12	ASF_SPAN_CAL_ACTVE	Instrument is performing Span Cal
13	PID_AUTO_ZERO	Baseline auto zero control status
14	PID_LAMP_CONTROL	PID Lamp Control status
Coils		
0	MB_SPAN_CAL_RANGE1	Control Span calibration
1	PID_LAMP_CONTROL	Turn On/Off PID Lamp
2	CONTROL_EXIT_STBY	Exit Standby Control
3	CONTROL_ENTER_STBY	Enter Standby Control
4	CONT_EXPORT_ENABLE	Cont Results Export
Input Registers		
0	BENZENE_CONC	Benzene Concentration
2	BENZENE_RETENTION_TIME	Ret Time Benz
4	BENZENE_STABILITY	Benzene Stability
6	TOLUENE_CONC	Toluene Concentration
8	TOLUENE_RETENTION_TIME	Ret Time Tol
10	TOLUENE_STABILITY	Toluene Stability
12	ETHYLBENZENE_CONC	Ethylbenzene Concentration
14	ETHYLBENZENE_RETENTION_TIME	Ret Time Ethyl
16	ETHYLBENZENE_STABILITY	Ethylbenzene Stability
18	MP-XYLENE_CONC	MP-Xylene Concentration
20	MP-XYLENE_RETENTION_TIME	Ret Time MP-Xyl
22	MP-XYLENE_STABILITY	MP-Xylene Stability
24	O-XYLENE_CONC	O-Xylene Concentration
26	O-XYLENE_RETENTION_TIME	Ret Time O-Xyl
28	O-XYLENE_STABILITY	O-Xylene Stability



ADDR	NAME	DESCRIPTION
30	COL1_TEMP	Column Temp
32	PRECONC_TEMP	Pre-concentrator Temp
34	AI_BOX_TEMP	Box Temp
36	INJECTOR_OVEN_TEMP	Main oven Temp
38	AI_PID_HEATER_TEMP	PID Heater Temp
40	AI_PID_HEATER_DUTY_CYCLE	PID Heater Duty Cycle
42	AI_PID_SIGNAL	PID Signal
44	AI_PID_SIGNAL_MEASUREMENT	PID Signal on measurement phase
46	AI_MEASURE_5V	5V Measure
48	AI_MEASURE_VDD	VDD Measure
50	RUN_TIME_REM	Run Time Remaining
52	AI_ATMOSPHERIC_PRESSURE	Atmospheric Pressure
54	CARR_GAS_PRESS	Carrier Press
Holding Registers		
0	INJECTOR_OVEN_TEMP	Main oven Temperature setpoint
2	ACQUISITION_TIME	The acquisition time for the PID signal
4	CARR_INTIAL_PRESS	Carrier gas pressure setpoint
6	DC_PUMP_FILL_TIME	DC pump fill time setpoint
8	PID_AUTO_ZERO_TIME	PID baseline autozero Period
10	SV_PID_HEATER_SET	PID Heater Temp Set Point
12	PUMP_START_TIME	Number of seconds before the end of acquisition for starting the pump
14	PRECONC_INTIAL_TEMP	PreCon Initial Temp
16	COL1_INTIAL_TEMP	Column Initial Temp
18	PRIGAS_PREC	Precision used when displaying a Primary Gas concentration



N904

APPENDIX B – INTERCONNECTS

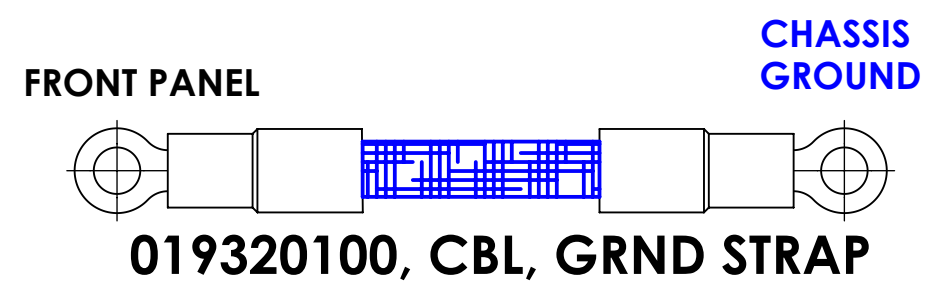

REVISION HISTORY					
ZONE	DCN	REV	DESCRIPTION	DATE	APPROVED
		01	INITIAL RELEASE, PROTOTYPE	10/28/2022	MM
		02	MODIFY THE PID BOARD	03/01/2024	MM
		03	CHANGE THE TEMPLATE	03/06/2024	MM

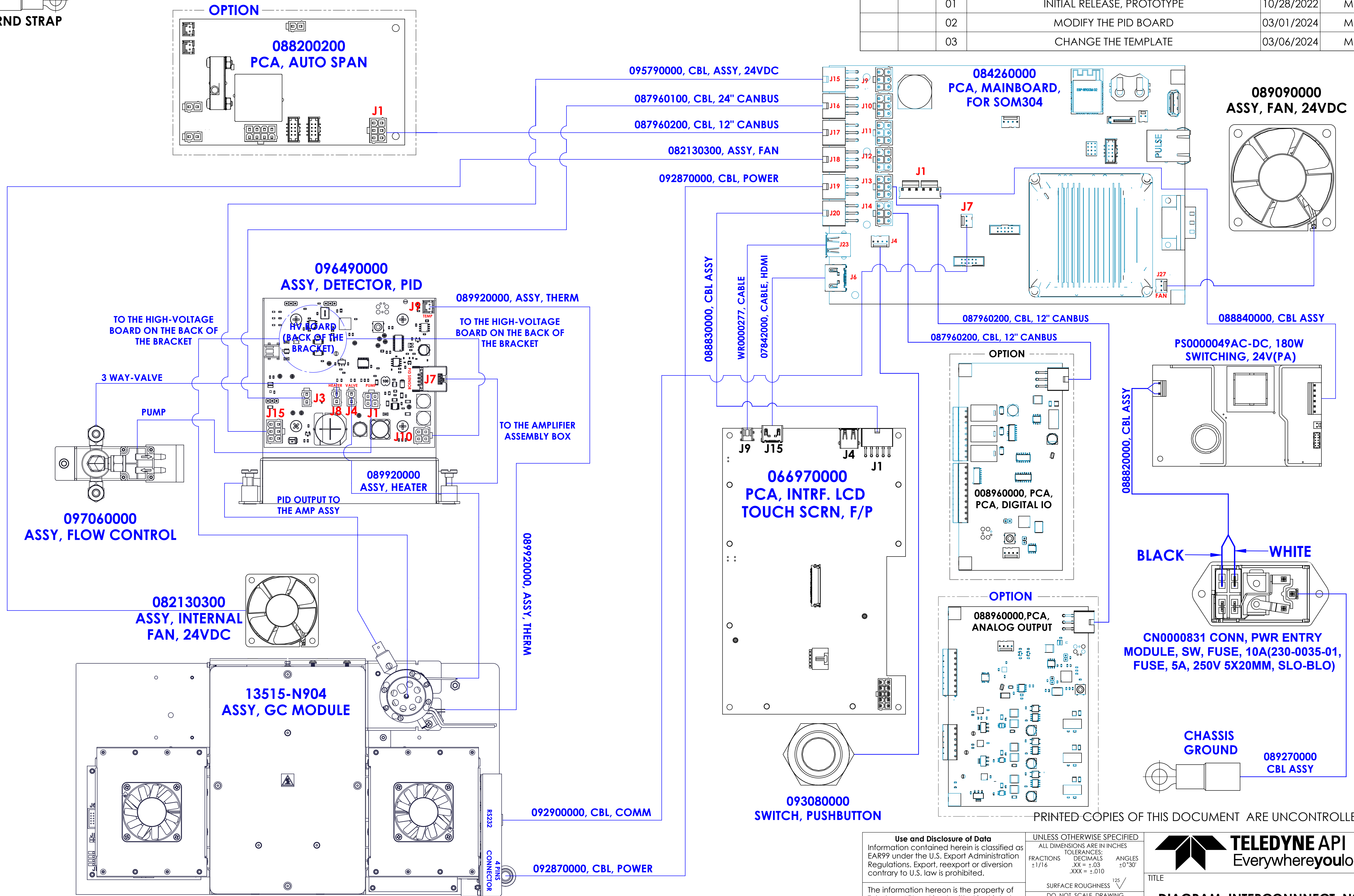

PRINTED COPIES OF THIS DOCUMENT ARE UNCONTROLLED

Use and Disclosure of Data
Information contained herein is classified as EAR99 under the U.S. Export Administration Regulations. Export, reexport or diversion contrary to U.S. law is prohibited.

The information hereon is the property of Teledyne API and is submitted in strictest confidence for reference only. Unauthorized use by anyone for any other purposes is prohibited. This document or any information contained in it may not be duplicated without proper authorization.

UNLESS OTHERWISE SPECIFIED
ALL DIMENSIONS ARE IN INCHES
TOLERANCES:
FRACTIONS DECIMALS ANGLES
±1/16 ±.03 ±0°30'

SURFACE ROUGHNESS 125
DO NOT SCALE DRAWING

THIRD ANGLE PROJECTION

APPROVALS DATE

TELEDYNE API
Everywhereyoulook™

TITLE
DIAGRAM, INTERCONNECT, N904

SIZE CAGE CODE DWG NO REV
D 3DCY1 093590940 03

SCALE 1:1 FORM ENF0029 Rev G SHEET 1 OF 1