



User Manual

Model N400
Photometric Ozone Analyzer



© Teledyne API (TAPI)
9970 Carroll Canyon Road
San Diego, California
92131-1106
USA

Toll-free Phone: +1 800-324-5190
Phone: +1 858-657-9800
Fax: +1 858-657-9816
Email: api-sales@teledyne.com
Website: <http://www.teledyne-api.com>



NOTICE OF COPYRIGHT

© 2024 Teledyne API (TAPI). All rights reserved.

TRADEMARKS

All trademarks, registered trademarks, brand names or product names appearing in this document are the property of their respective owners and are used herein for identification purposes only.

SAFETY MESSAGES

Important safety messages are provided throughout this manual for the purpose of avoiding personal injury or instrument damage. Please read these messages carefully. Each safety message is associated with a safety alert symbol and is placed throughout this manual; the safety symbols are also located inside the instrument. It is imperative that you pay close attention to these messages, the descriptions of which are as follows:



WARNING: Electrical Shock Hazard



HAZARD: Strong oxidizer



GENERAL WARNING/CAUTION: Read the accompanying message for specific information.



CAUTION: Hot Surface Warning



Do Not Touch: Touching some parts of the instrument without protection or proper tools could result in damage to the part(s) and/or the instrument.



Technician Symbol: All operations marked with this symbol are to be performed by qualified maintenance personnel only.



Electrical Ground: This symbol inside the instrument marks the central safety grounding point for the instrument.

CAUTION

This product should only be installed, commissioned, and used strictly for the purpose and in the manner described in this manual. If you improperly install, commission, or use this instrument in any manner other than as instructed in this manual or by our Technical Support team, unpredictable behavior could ensue with possible hazardous consequences.

Such risks, whether during installation and commission or caused by improper installation/commissioning/use, and their possible hazardous outcomes include but are not limited to:



RISK	HAZARD
Liquid or dust/debris ingress	Electrical shock hazard
Improper or worn power cable	Electrical shock or fire hazard
Excessive pressure from improper gas bottle connections	Explosion and projectile hazard
Sampling combustible gas(es)	Explosion and fire hazard
Improper lift & carry techniques	Personal injury

Note that the safety of a system that may incorporate this product is the end user's responsibility.

For Technical Assistance regarding the use and maintenance of this instrument or any other Teledyne API product, contact Teledyne API's Technical Support Department:

Telephone: +1 800-324-5190 (toll free) or +1 858-657-9800

Email: api-techsupport@teledyne.com

or access any of the service options on our website at <http://www.teledyne-api.com/>

CONSIGNES DE SÉCURITÉ

Des consignes de sécurité importantes sont fournies tout au long du présent manuel dans le but d'éviter des blessures corporelles ou d'endommager les instruments. Veuillez lire attentivement ces consignes. Chaque consigne de sécurité est représentée par un pictogramme d'alerte de sécurité; ces pictogrammes se retrouvent dans ce manuel et à l'intérieur des instruments. Les symboles correspondent aux consignes suivantes :



AVERTISSEMENT : Risque de choc électrique



DANGER : Oxydant puissant



AVERTISSEMENT GÉNÉRAL / MISE EN GARDE : Lire la consigne complémentaire pour des renseignements spécifiques



MISE EN GARDE : Surface chaude



Ne pas toucher : Toucher à certaines parties de l'instrument sans protection ou sans les outils appropriés pourrait entraîner des dommages aux pièces ou à l'instrument.



Pictogramme « technicien » : Toutes les opérations portant ce symbole doivent être effectuées uniquement par du personnel de maintenance qualifié.



Mise à la terre : Ce symbole à l'intérieur de l'instrument détermine le point central de la mise à la terre sécuritaire de l'instrument.

MISE EN GARDE

Ce produit ne doit être installé, mis en service et utilisé qu'aux fins et de la manière décrites dans le présent manuel. Si vous installez, mettez en service ou utilisez cet instrument de manière incorrecte autre que celle indiquée dans ce manuel ou sous la direction de notre équipe de soutien technique, un comportement imprévisible pourrait entraîner des conséquences potentiellement dangereuses.

Ce qui suit est une liste, non exhaustive, des risques et résultats dangereux possibles associés avec une mauvaise utilisation, une mise en service incorrecte, ou causés mauvaise commission.



RISQUE	DANGER
Pénétration de liquide ou de poussière/débris	Risque de choc électrique
Câble d'alimentation incorrect, endommagés ou usé	Choc électrique ou risque d'incendie
Pression excessive due à des connexions de bouteilles de gaz incorrectes	Risque d'explosion et d'émission de projectile
Échantillonnage de gaz combustibles	Risque d'explosion et d'incendie
Techniques de manutention, soulevage et de transport inappropriées	Blessure corporelle

Notez que la sécurité d'un système qui peut incorporer ce produit est la responsabilité de l'utilisateur final.



WARRANTY

WARRANTY POLICY (02024J)

Teledyne API (TAPI), a business unit of Teledyne Instruments, Inc., provides that:

Prior to shipment, TAPI equipment is thoroughly inspected and tested. Should equipment failure occur, TAPI assures its customers that prompt service and support will be available. (For the instrument-specific warranty period, please refer to the “Limited Warranty” Section in the Terms and Conditions of Sale on our website: <http://www.teledyne-api.com>).

COVERAGE

After the warranty period and throughout the equipment lifetime, TAPI stands ready to provide on-site or in-plant service at reasonable rates similar to those of other manufacturers in the industry. All maintenance and the first level of field troubleshooting are to be performed by the customer.

NON-TAPI MANUFACTURED EQUIPMENT

Equipment provided but not manufactured by TAPI is warranted and will be repaired to the extent and according to the current terms and conditions of the respective equipment manufacturer’s warranty.

PRODUCT RETURN

All units or components returned to Teledyne API should be properly packed for handling and returned freight prepaid to the nearest designated Service Center. After the repair, the equipment will be returned, freight prepaid.

The complete Terms and Conditions of Sale can be reviewed on our website.

CAUTION – Avoid Warranty Invalidation



Failure to comply with proper anti-Electro-Static Discharge (ESD) handling and packing instructions and Return Merchandise Authorization (RMA) procedures when returning parts for repair or calibration may void your warranty. For anti-ESD handling and packing instructions please refer to the manual, Fundamentals of ESD, PN 04786, in its “Packing Components for Return to Teledyne API’s Customer Service” section. The manual can be downloaded from our website at <http://www.teledyne-api.com>. RMA procedures can also be found on our website.



ABOUT THIS MANUAL

Support manuals that are available on the CD of Instrument User Manuals and on the TAPI website <http://www.teledyne-api.com> include:

- NumaView™ Remote Software User Guide, part number 08492
- Fundamentals of ESD Manual, part number 04786 (to prevent Electro-Static Discharge and consequent damage to instrument)
- Pump Pack Manual, part number 07900 (if option installed)

NOTE

We recommend that all users read this manual in its entirety before operating the instrument.

CONVENTIONS USED

In addition to the safety symbols as presented in the *Safety Messages* page, this manual provides *special notices* related to the careful and effective use of the instrument and related, pertinent information.

ATTENTION

COULD DAMAGE INSTRUMENT AND VOID WARRANTY

This special notice provides information to avoid damage to your instrument and possibly invalidate the warranty.

IMPORTANT

IMPACT ON READINGS OR DATA

Provides information about that which could either affect accuracy of instrument readings or cause loss of data.

NOTE

Provides information pertinent to the proper care, operation or maintenance of the instrument or its parts.



TABLE OF CONTENTS

1. Introduction, Specifications, Approvals, & Compliance.....	14
1.1 Specifications.....	15
1.2 EPA Designation	16
1.3 Compliance and Certifications.....	16
2. Getting Started.....	17
2.1 Unpacking.....	17
2.1.1 Ventilation Clearance	18
2.2 Instrument Layout.....	19
2.2.1 Front Panel.....	19
2.2.2 Rear panel.....	20
2.2.3 Internal Chassis	22
2.3 Connections and Startup.....	23
2.3.1 Electrical Connections.....	23
2.3.1.1 Connecting Power	23
2.3.1.2 Connecting Analog Outputs (Option)	24
2.3.1.3 Connecting the Digital I/O Expansion Board Option	25
2.3.1.4 Connecting Communications Interfaces.....	26
2.3.2 Pneumatic Connections	27
2.3.2.1 Important Information About Calibration Gases	28
2.3.2.2 Pneumatic Connections: Basic Configuration	29
2.3.2.3 Pneumatic Connections: Zero/Span (Z/S) Option	30
2.3.2.4 Pneumatic Connections: Internal Zero/Span (IZS) Option.....	32
2.3.2.5 Pneumatic Connections: Ambient Air Monitoring in Same Room.....	33
2.3.2.6 Pneumatic Connections: Ambient Air Monitoring in Remote Locations.....	34
2.3.3 Pneumatic Flow Diagrams	35
2.3.3.1 Pneumatic Flow: Basic Configuration.....	35
2.3.3.2 Pneumatic Flow: Zero/Span (ZS) Valve Option	36
2.3.3.3 Pneumatic Flow: Internal Zero/Span (IZS) Valve Option	37
2.3.4 Startup, Functional Checks, and Initial Calibration	38
2.3.4.1 Startup.....	38
2.3.4.2 Alerts: Warnings and Other Messages.....	39
2.3.4.3 Functional Checks	40
2.3.4.4 Initial Calibration	40
2.4 Menu Overview.....	41
2.4.1 Home Page	42
2.4.2 Dashboard.....	44
2.4.3 Alerts	46
2.4.4 Calibration	47
2.4.5 Utilities.....	48
2.4.6 Setup	48
2.5 Setup Menu: Features/Functions Configuration.....	49
2.5.1 Setup>Data Logging (Data Acquisition System, DAS)	49
2.5.1.1 Configuring Trigger Types: Periodic.....	51
2.5.1.2 Configuring Trigger Types: Conditional.....	51
2.5.1.3 Downloading DAS (Data Acquisition System) Data	52
2.5.2 Setup>Events.....	52
2.5.2.1 Editing or Deleting Events	54
2.5.2.2 Using Events as Triggers for Data Logging.....	55
2.5.3 Setup>Dashboard	55
2.5.4 Setup>AutoCal (with Valve Option)	55
2.5.5 Setup>Vars	56
2.5.6 Setup>Homescreen	57



2.5.7	Setup>Digital Outputs (Option)	58
2.5.8	Setup>Analog Outputs (Options)	59
2.5.8.1	Manual Calibration of Voltage Range Analog Outputs	61
2.5.8.2	Manual Adjustment of Current Range Analog Outputs	61
2.5.9	Setup>Instrument	62
2.5.10	Setup>Comm (Communications)	63
2.5.10.1	COM2	63
2.5.10.2	TCP Port2	63
2.5.10.3	Network Settings	64
2.6	Transferring Configuration to Other Instruments	65
3	Communications and Remote Operation	66
3.1	Serial Communication	66
3.1.1	MODBUS	66
3.1.2	Hessen	67
3.2	Ethernet	69
3.3	NumaView™ Remote	69
4	Calibration	70
4.1	Important Precalibration Information	70
4.1.1	Calibration Requirements	70
4.1.2	Zero Air	70
4.1.3	Calibration (Span) Gas	70
4.1.4	Interferents	71
4.1.5	Dilution Ratio Option Software Set Up	71
4.1.6	Data Recording Devices	71
4.2	Calibration Procedures	72
4.2.1	Calibration and Check Procedures for Basic Configuration	72
4.2.1.1	Zero Calibration Check and Actual Calibration	73
4.2.1.2	Span Calibration Check and Actual Calibration	73
4.2.2	Calibration and Check Procedures with Valve Options Installed	74
4.2.2.1	Remote Contact Closure and Cal/Cal Checks with Zero/Span Valve	75
4.3	Automatic Zero/Span Cal/Check (Auto Cal)	75
4.4	Calibration Quality	77
4.5	Calibration of the Electronic Subsystems	77
4.5.1	Pressure Calibration	77
4.5.2	Flow Calibration	78
4.5.3	O ₃ Gen Calibration (with IZS Option)	78
5	Maintenance and Service	79
5.1	Maintenance Schedule	79
5.2	Predictive Diagnostics	83
5.3	Operational Health Checks	84
5.4	Software/Firmware Updates	84
5.4.1	Remote Updates	84
5.4.2	Manual Reload/Update Procedures	85
5.5	Time Zone Changes	86
5.6	Maintenance Procedures	87
5.6.1	Replacing the 47 MM Sample Particulate Filter Option	87
5.6.2	Replacing the DFU Filter Option	88
5.6.3	Replacing the IZS Option Zero Air Scrubber	88
5.6.4	Performing Leak Checks	90
5.6.4.1	Vacuum Leak Check and Pump Check	90
5.6.4.2	Pressure Leak Check	90
5.6.5	Performing a Sample Flow Check	91
5.6.6	Maintaining the Photometer Absorption Tube	91
5.6.7	Replacing the Optical Bench UV Lamp	92
5.6.8	Adjusting or Replacing the IZS Ozone Generator Option's UV Lamp	93



5.7	Troubleshooting	94
5.7.1	Fault Diagnosis with Alerts	95
5.7.2	Fault Diagnosis with Dashboard Functions	96
5.7.3	The Diagnostic Signal I/O Function	97
5.7.4	Fault Diagnosis with Board LEDs	98
5.7.5	Flow Problems	100
5.7.5.1	Flow is Zero	100
5.7.5.2	Low Flow	101
5.7.5.3	High Flow	101
5.7.5.4	Actual Flow Does Not Match Displayed Flow	102
5.7.5.5	Sample Pump	102
5.7.6	Calibration Problems	102
5.7.6.1	Miscalibrated	102
5.7.6.2	Non-Repeatable Zero and Span	102
5.7.6.3	Inability to Span – No SPAN Button (CALS)	103
5.7.6.4	Inability to Zero – No ZERO Button (CALZ)	103
5.7.7	Other Performance Problems	103
5.7.8	Temperature Problems	103
5.7.8.1	Box Temperature	103
5.7.8.2	Sample Temperature	103
5.7.8.3	UV Lamp Temperature	104
5.7.8.4	IZS Option Ozone Generator Temperature	104
5.7.9	Subsystem Checkout	104
5.7.9.1	AC Main Power	104
5.7.9.2	LCD Display Module	105
5.7.9.3	RS-232 Communications	105
5.7.10	Troubleshooting the Photometer	106
5.7.10.1	Checking the Measure/Reference Valve	106
5.8	Service Procedures	106
5.8.1	Replacing the Fuse	107
5.8.2	Replacing a Module	108
5.8.2.1	Connectors on Mainboard	108
5.8.2.2	Connectors on DC Pump PCA	109
5.8.2.3	Connectors on Ozone Generator Lamp PCA	110
5.8.2.4	Connector on Ozone Generator UV Detector	110
5.8.3	Replacing the Standard Reference O ₃ Scrubber	110
5.8.4	Replacing the IZS O ₃ Scrubber	111
5.8.5	Replacing the Metal Wool Scrubber Option	111
5.9	Frequently Asked Questions	112
5.10	Technical Assistance	113
6.	Theory of Operation	114
6.1	Measurement Method	114
6.1.1	Calculating O ₃ Concentration	115
6.1.2	The Photometer UV Absorption Path	116
6.1.3	The Reference / Measurement Cycle	117
6.1.4	Interferent Rejection	117
6.1.4.1	Aromatic Hydrocarbons	118
6.1.4.2	Mercury Vapor	118
6.2	Pneumatic Operation	118
6.2.1	Sample Gas Air Flow	118
6.2.2	Flow Rate Control	119
6.2.3	Particulate Filter	120
6.2.4	Pneumatic Sensors	120
6.2.4.1	Sample Pressure Sensor	120
6.2.4.2	Sample Flow Sensor	120



6.3 Electronic Operation	120
6.3.1 Modules	120
6.3.2 Power Switches	121
6.4 Software Operation	121
6.4.1 Adaptive Filter	121
6.4.2 Calibration - Slope and Offset	122

Appendix A – MODBUS Registers
Appendix B – Interconnect Diagram

FIGURES

Figure 2-1. Front Panel Layout	19
Figure 2-2. Rear Panel Layout	20
Figure 2-3. N400 Internal Layout – Top View with IZS Option	22
Figure 2-4. Analog Outputs Connectors Panel Option	24
Figure 2-5. Digital I/O Connector Panel Option	25
Figure 2-6. Mainboard JP1 Location and Pin Arrangements	26
Figure 2-7. Gas Line Connections for the N400 Analyzer – Basic Configuration	29
Figure 2-8. Gas Line Connections for the N400 Analyzer with Zero/Span Valve Option	30
Figure 2-9. Gas Line Connections for the N400 Analyzer with IZS Option	32
Figure 2-10. Gas Line Connections when the N400 Analyzer is Located in the Room Being Monitored	33
Figure 2-11. Gas Line Connections when the N400 Analyzer is Monitoring a Remote Location	34
Figure 2-12. N400 Pneumatic Diagram – Basic Unit	35
Figure 2-13. N400 Pneumatic Diagram with Zero/Span (ZS) Option	36
Figure 2-14. N400 Pneumatic Diagram with Internal Zero/Span (IZS) Option	37
Figure 2-15. Status Screens at Startup	38
Figure 2-16. Home Page Example	39
Figure 2-17. Viewing Active Alerts Page	39
Figure 2-18. Sample Dashboard Page	40
Figure 2-19. User Interface Orientation	42
Figure 2-20. Concentration and Stability Graph (top) and Meter Graph (bottom)	43
Figure 2-21. Dashboard Page	44
Figure 2-22. Navigating to the Active Alerts Page	46
Figure 2-23. Active Alerts Cleared	47
Figure 2-24. Utilities>Alerts Log of Active and Past Alerts and Events	47
Figure 2-25. Datalog Configuration, New Log Page	49
Figure 2-26. Datalog Configuration, Existing Log	49
Figure 2-27. Creating a New Data Log	50
Figure 2-28. Datalog Periodic Trigger Configuration	51
Figure 2-29. Datalog - Conditional Trigger Configuration	51
Figure 2-30. DAS Download Page	52
Figure 2-31. Events List	52
Figure 2-32. Event Configuration	53
Figure 2-33. Configured Event Sample	54
Figure 2-34. Edit or Delete an Event	54
Figure 2-35. Dashboard Display and Configuration	55
Figure 2-36. Homescreen Configuration	57
Figure 2-37. Digital Outputs Setup	58
Figure 2-38. Analog Output Configuration Example	59
Figure 2-39. Analog Outputs Group Calibration Screen	60
Figure 2-40. Analog Outputs Manual Calibration Screen (AOUT2 Example)	60
Figure 2-41. Setup for Checking / Calibrating DCV Analog Output Signal Levels	61



Figure 2-42. Setup for Checking / Calibration Current Output Signal Levels.....	62
Figure 2-43. Communications Configuration, Network Settings	64
Figure 2-44. Configuration Transfer	65
Figure 4-1. Multi-Point Calibration Page	73
Figure 4-2. Zero and Span Calibration Screens.....	74
Figure 4-3. Auto Cal Page	76
Figure 5-1. Report Generation Page	84
Figure 5-2. Remote Update Page.....	84
Figure 5-3. Manual Update Page (and other utilities).....	85
Figure 5-4. Time Zone Change Requirements	86
Figure 5-5. Replacing the Particulate Filter	87
Figure 5-6. Replacing the IZS Zero Air Scrubber	89
Figure 5-7. O ₃ Generator UV Lamp.....	93
Figure 5-8. Mainboard	98
Figure 5-9. Ozone Sensor Board LEDs.....	99
Figure 5-10. DC Pump Control Board LEDs	99
Figure 5-11. HD non-PID Controlled Pump.....	100
Figure 5-13. Fuse Access.....	107
Figure 5-14. Mainboard Connectors.....	108
Figure 5-15. DC Pump Control Board Connectors.....	109
Figure 5-16. Ozone Generator Lamp PCA.....	110
Figure 5-17. Ozone Generator UV Detector PCA	110
Figure 5-18. IZS O ₃ Generator Zero Air Scrubber Location	111
Figure 6-1. O ₃ Absorption Path	116
Figure 6-2. Flow Control Assembly & Critical Flow Orifice.....	119

TABLES

Table 1-1. N400 Basic Unit Specifications	15
Table 1-2. IZS Generator Specifications <i>with</i> Reference Feedback Option.....	16
Table 1-3. IZS Generator Specifications <i>without</i> Reference Feedback Option	16
Table 2-1. Ventilation Clearance	18
Table 2-2. Rear Panel Description	21
Table 2-3. Analog Output Pin Assignments	24
Table 2-4. Digital Input/Output Pin Assignments.....	25
Table 2-5. JP1 Configurations for Serial Communication	26
Table 2-6. Operating States for Zero/Span Valve Option	36
Table 2-7. Operating States for Internal Zero/Span Valve Option	37
Table 2-8. Menu Overview	41
Table 2-9. Common Dashboard Parameters	45
Table 2-10. Utilities Submenu Descriptions	48
Table 2-11. List of Variables with Descriptions	56
Table 2-12. Analog Output Voltage/Current Range	60
Table 2-13. Voltage Tolerances	61
Table 2-14. Setup>Instrument Menu	62
Table 2-15. COM Port Configuration	63
Table 2-16. LAN/Ethernet Configuration Properties.....	64
Table 3-1. Teledyne API's Hessen Protocol Response Modes.....	67
Table 3-2. Hessen List Configuration Summary.....	68
Table 3-3. REST Resource Descriptions	68
Table 3-4. Ethernet Status Indicators	69
Table 4-1. Auto Cal Programming Sequence Execution.....	76
Table 5-1. N400 Maintenance Schedule	81
Table 5-2. Predictive Uses for Dashboard Functions.....	83



N400

Table 5-3. Alerts - Indicated Failures.....	95
Table 5-4. Dashboard Functions - Indicated Failures	96



1. INTRODUCTION, SPECIFICATIONS, APPROVALS, & COMPLIANCE

Teledyne API's microprocessor-controlled Model N400 measures low ranges of ozone in ambient air using a method based on the Beer-Lambert law that relates the absorption of light to the properties of the material through which the light is traveling over a defined distance. In the N400 the intensity of an ultraviolet light is measured after it passes through a chamber, called the sample cell, where it is absorbed in proportion to the amount of ozone present. Every four seconds, a switching valve alternates measurement between a gas stream containing ozone and a stream that has been scrubbed of ozone. These measurements are calculated along with the ambient sample gas pressure and temperature to provide a true, stable ozone measurement.

The N400 tracks operational parameters and issues warnings if they fall outside diagnostic limits, as well as stores easily retrievable data. Proprietary software allows configurable data acquisition capability that can be triggered conditionally or periodically, enabling operators to perform predictive diagnostics and enhanced data analysis by tracking parameter trends. Reports can be downloaded onto a USB flash drive or via the I/O ports. Operators can also view real-time graphing with one touch of the interface screen.



1.1 SPECIFICATIONS

Table 1-1. N400 Basic Unit Specifications

PARAMETER	SPECIFICATION	
Ranges	Min: 0-100 ppb Full scale Max: 0-10,000 ppb Full scale (selectable, dual range supported)	
Measurement Units	ppb, ppm, $\mu\text{g}/\text{m}^3$, mg/m^3 (selectable)	
Zero Noise	< 0.2 ppb (RMS) (with 80 Sample Digital Filter)	
Span Noise	< 0.5% of reading (RMS) above 100 ppb	
Lower Detectable Limit	< 0.4 ppb (with 80 Sample Digital Filter)	
Zero Drift	< 1.0 ppb/24 hours	
Span Drift	< 1% of reading/24 hours	
Response Time	< 30 sec to 95%	
Linearity	1% of full scale	
Precision	0.5% of reading above 100 ppb	
Sample Flow Rate	800 cc/min \pm 10%	
Power Requirements	Rating	Typical Power Consumption
	100V-240V, 50/60 Hz	40 W
Power Entry Module Fuse	5.0 A, 250 V AC, 5 mm x 20 mm, SLO-BLO	
Communications		
Standard I/O	1 Ethernet: TCP/IP 1 RS-232 (300 – 115,200 baud) 2 front panel USB device ports	
Optional I/O	Universal Analog Output Board (all user-definable): 4 x isolated voltage outputs (5 V, 10 V) 3 x individually isolated current outputs (4-20 mA) Digital I/O Expansion Board includes: 3 x isolated digital input controls (fixed) 5 x isolated digital output controls (user-definable) 3 x form C relay alarm outputs	
Operating Temperature Range	0 - 45°C (with EPA Equivalency)	
Humidity Range	0-90% RH, Non-Condensing	
Pressure Range	25 – 31 "Hg-A	
Temp Coefficient	< 0.05% per deg C	
Voltage Coefficient	< 0.05% per Volt AC (RMS) over range of nominal \pm 10%	
Dimensions (H x W x D)	7" x 17" x 24.3" (178 x 432 x 617 mm)	
Weight	28 lbs (12.7 kg)	
	30.6lbs. (13.8kg) with IZS Option	
Environmental Conditions	Installation Category (Over voltage Category) II Pollution Degree 2 Intended for indoor use only at altitudes \leq 2000m	



Table 1-2. IZS Generator Specifications *with* Reference Feedback Option

PARAMETER	SPECIFICATION
Maximum Concentration	1.0 ppm
Minimum Concentration	0.050 ppm
Resolution	0.5 ppb
Repeatability (7 days)	1% of reading
Initial Accuracy	+/- 5% of target concentration
Response Time	< 5 min to 95%

Table 1-3. IZS Generator Specifications *without* Reference Feedback Option

PARAMETER	SPECIFICATION
Maximum Concentration	1.0 ppm
Minimum Concentration	0.050 ppm
Resolution	0.5 ppb
Repeatability (7 days)	2% of reading
Initial Accuracy	+/- 10% of target concentration
Response Time	< 5 min to 95%

1.2 EPA DESIGNATION

Teledyne API's Model N400 photometric ozone analyzer is officially designated as US EPA Federal Equivalent Method (FEM), Designation Number EQOA-0992-087. The official "List of Designated Reference and Equivalent Methods" is published in the U.S. Federal Register: <http://www3.epa.gov/ttn/amtic/criteria.html>, and specifies the instrument's settings and configurations.

1.3 COMPLIANCE AND CERTIFICATIONS

This product is CE compliant and adheres to the Low Voltage and Electromagnetic Compatibility Directives.

For any other certifications, please refer to our website for the product specifications sheet.

2. GETTING STARTED

This Section addresses unpacking, connecting, and initializing the instrument, getting an overview of the menu system, and setting up/configuring the functions.

2.1 UNPACKING



CAUTION - GENERAL SAFETY HAZARD

To avoid personal injury, always use two persons and proper lift and carry techniques to move/relocate the analyzer.

ATTENTION

COULD DAMAGE INSTRUMENT AND VOID WARRANTY

Printed Circuit Assemblies (PCAs) are sensitive to electro-static discharges too small to be felt by the human nervous system. Failure to use Electro-Static Discharge (ESD) protection when working with electronic assemblies will void the instrument warranty. Refer to the manual, Fundamentals of ESD, PN 04786, which can be downloaded from our website at <http://www.teledyne-api.com>.

ATTENTION

COULD DAMAGE INSTRUMENT AND VOID WARRANTY

Do not operate this instrument without first removing dust plugs from SAMPLE and EXHAUST ports on the rear panel.

Note

Teledyne API recommends that you store shipping containers and materials for future use if/when the instrument should be returned to the factory for repair and/or calibration service. See Warranty statement in this manual and Return Merchandise Authorization (RMA) on our Website at <http://www.teledyne-api.com>.

Verify that there is no apparent external shipping damage. If damage has occurred, please advise the shipper first, then Teledyne API.

Included with your instrument is a printed record of the final performance characterization performed on your instrument at the factory. This record, titled Final Test and Validation Data Sheet, is an important quality assurance and calibration record and should be placed in the quality records file for this instrument.

With no power to the unit, carefully remove the top cover of the instrument and check for internal shipping damage by carrying out the following steps:

1. Carefully remove the top cover and check for internal shipping damage.
 - a. Remove the screws located on the instrument's sides.
 - b. Slide cover backward until it clears the instrument's front bezel.
 - c. Lift cover straight up.
2. Inspect instrument interior to ensure all circuit boards and other components are intact and securely seated.
3. Check the connectors of the various internal wiring harnesses and pneumatic hoses to ensure they are firmly and securely seated.
4. Verify that all of the optional hardware ordered with the unit has been installed. These are listed on the paperwork accompanying the instrument.



WARNING – ELECTRICAL SHOCK HAZARD

Never disconnect or reconnect PCAs, wiring harnesses or electronic subassemblies while instrument is under power.

2.1.1 VENTILATION CLEARANCE

Whether the analyzer is set up on a bench or installed into an instrument rack, be sure to leave sufficient ventilation clearance.

Table 2-1. Ventilation Clearance

AREA	MINIMUM REQUIRED CLEARANCE
Back of the instrument	10 cm / 4 in
Sides of the instrument	2.5 cm / 1 in
Above and below the instrument	2.5 cm / 1 in

Various rack mount kits are available for this analyzer. Contact Sales for more information.

2.2 INSTRUMENT LAYOUT

Instrument layout includes front panel, rear panel connectors, and internal chassis layout.

2.2.1 FRONT PANEL

The front panel (Figure 2-1) includes two USB ports for peripheral device connections, which can be used with mouse and keyboard as alternatives to the touchscreen interface, or with flash drive for uploads/downloads (devices not included).

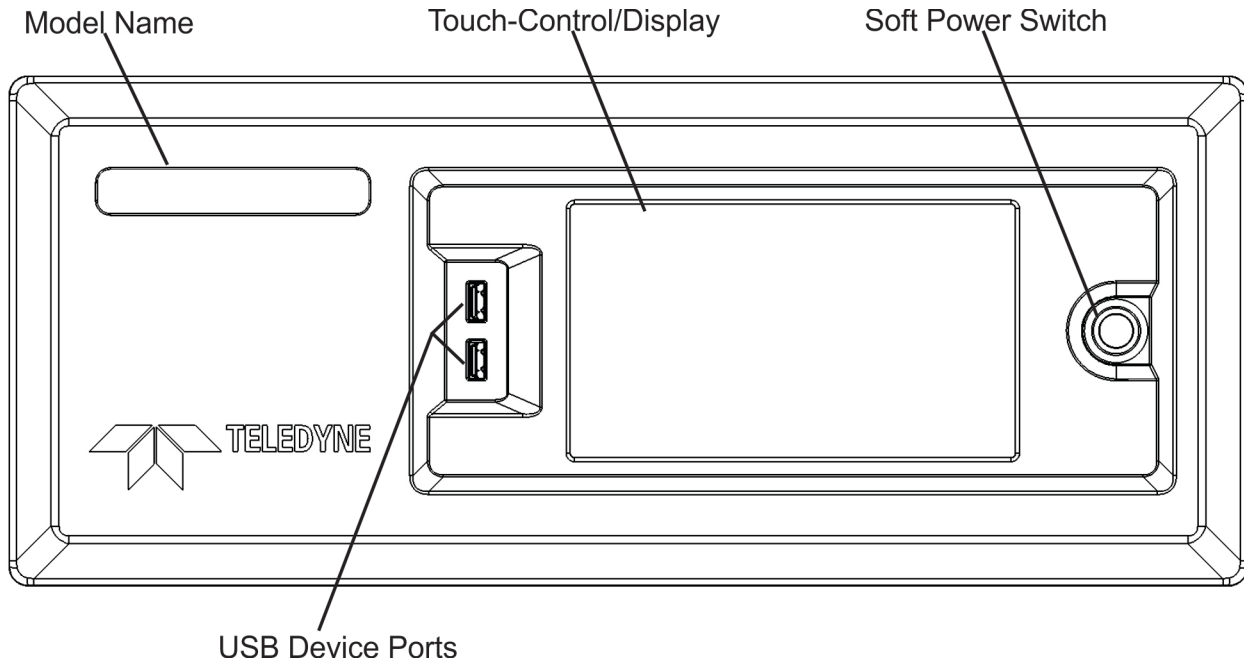

Figure 2-1. Front Panel Layout

2.2.2 REAR PANEL

Figure 2-2 shows the layout of the rear panel. Table 2-2 provides a description.

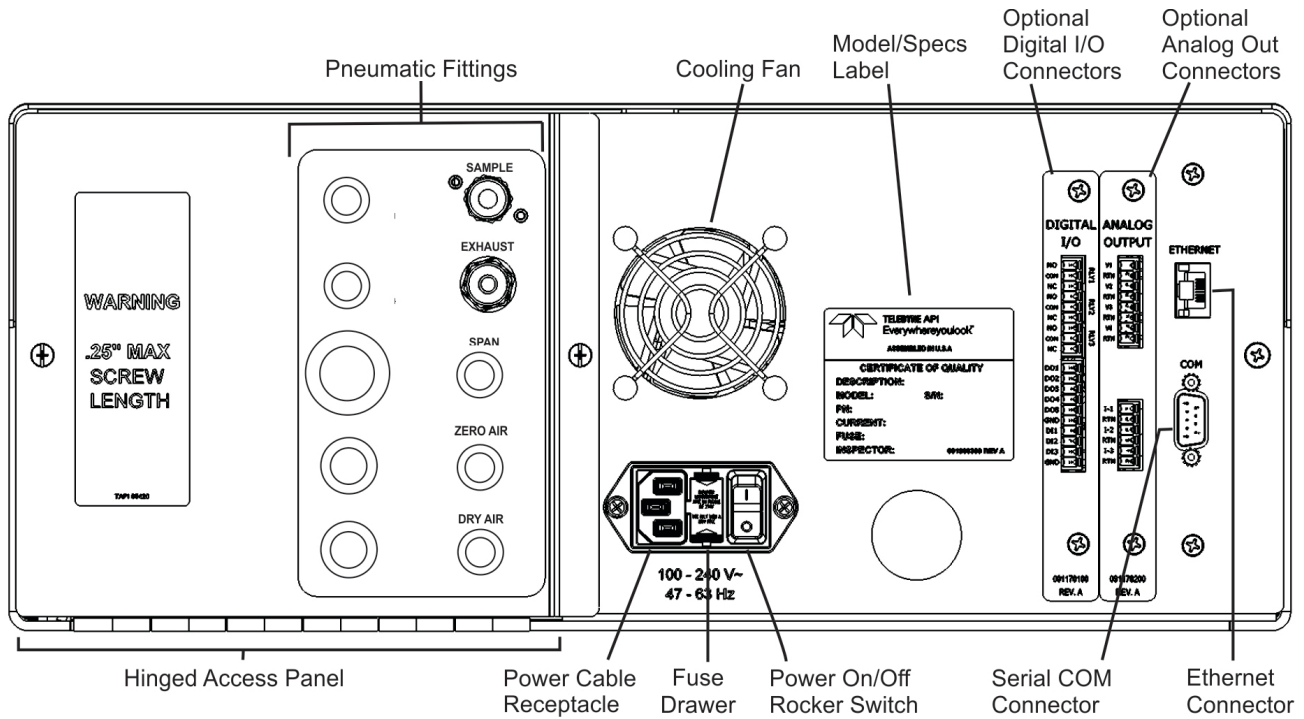



Figure 2-2. Rear Panel Layout



Table 2-2. Rear Panel Description

COMPONENT	FUNCTION
SAMPLE	Connect a gas line from the source of sample gas here. Calibration gases are also inlet here on units with the zero/span valve option installed.
EXHAUST	Connect an exhaust gas line of not more than 10 meters long here that leads outside the shelter or immediate area surrounding the instrument.
SPAN (option)	On units with zero/span valve option installed, connect a gas line to the source of calibrated span gas here.
ZERO AIR (option)	Internal Zero Air: On units with zero/span valve option installed connect the source of zero air here.
DRY AIR (option)	On units with zero/span valve option installed connect the source of dry air here (- <20°C dew point).
Cooling fan	Pulls ambient air into chassis through side vents and exhausts through rear. (software controlled to Box Temp setpoint).
Model/specs label	Identifies the analyzer model number and provides power specs.
	Power cable receptacle Connector for three-prong cord to apply AC power to the analyzer CAUTION! The cord's power specifications (specs) MUST comply with the power specs on the analyzer's rear panel label
	Power On/Off Switch Rocker switch to power unit on or off. CAUTION! Prior to powering OFF, use front panel button for preliminary internal "soft" power-down to protect components from damage.
Fuse drawer	For circuit protection
DIGITAL I/O Option	For remotely activating the zero and span calibration modes.
ANALOG OUT Option	For voltage or current loop outputs to a strip chart recorder and/or a data logger.
ETHERNET	Connector for network or Internet remote communication, using Ethernet cable.
COM	Serial communications port for RS-232

2.2.3 INTERNAL CHASSIS



CAUTION – UV RADIATION RISK

Do not look directly at the light of the UV lamp. Use proper UV-protective lenses.

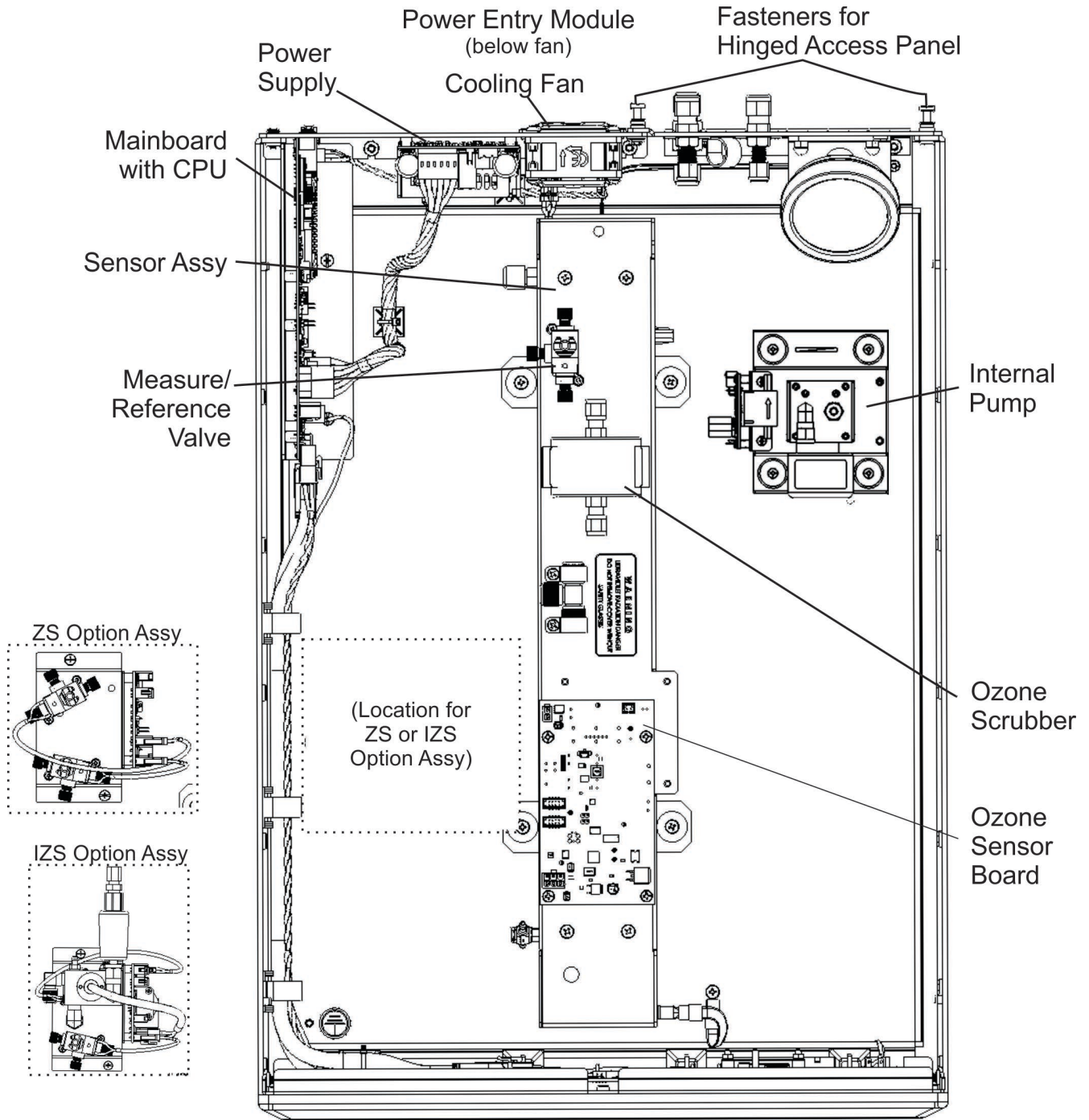

Figure 2-3. N400 Internal Layout – Top View

2.3 CONNECTIONS AND STARTUP

This Section presents the electrical (Section 2.3.1) and pneumatic (Section 2.3.2) connections for setup and preparing for instrument operation.

2.3.1 ELECTRICAL CONNECTIONS

Note To maintain compliance with EMC standards, cables must be no longer than 3 meters for all I/O connections.



WARNING – ELECTRICAL SHOCK HAZARD

- High Voltages are present inside the instrument's case.
- Power connection must have functioning ground connection.
- Do not defeat the ground wire on power plug.
- Turn off instrument power before disconnecting or connecting electrical subassemblies.
- Do not operate with cover off.
- Ensure that installation provides access to disconnect power from the instrument



CAUTION – AVOID DAMAGE TO THE INSTRUMENT

Ensure that the AC power voltage matches the voltage indicated on the instrument's rear panel before plugging it into line power.

2.3.1.1 CONNECTING POWER

Important

COULD CAUSE LOSS OR CORRUPTION OF DATA

Never power off the instrument from the rear panel Hard Power switch before first using the front panel Soft Power switch, which triggers the Supervisory chip to safely shut down the internal computerized components and preserve data. Press and hold the front panel Soft Power switch until the instrument stops running; the LED state then changes from solid lit to blinking, at which time either the rear panel Hard Power switch can be used to finish powering off the instrument if needed, or the Soft Power switch can be pressed again later to restart the instrument.

Attach the power cord between the instrument's AC power connector and a power outlet capable of carrying at least the rated current at your AC voltage range and ensure that it is equipped with a functioning earth ground. It is important to adhere to all safety and cautionary messages.

2.3.1.2 CONNECTING ANALOG OUTPUTS (OPTION)

The optional rear panel Analog Output board offers several channels that can be mapped to reflect various operating values in the analyzer, including concentration values, temperatures, pressures, etc. These mappings are not configured by default and must be set by the user.

The four **voltage** outputs (0-5 V or 0-10 V) are isolated from the instrument but share a common ground. The three **current** outputs are individually isolated from each other and from the instrument.

To access these signals, attach a strip chart recorder and/or data-logger to the appropriate analog output connections, and configure through the Setup>Analog Outputs menu.

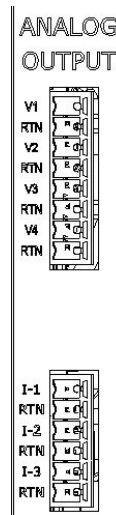

Figure 2-4. Analog Outputs Connectors Panel Option

Table 2-3. Analog Output Pin Assignments

PIN	OUTPUT	DESCRIPTION
Isolated Voltage Outputs		
V1	V +	User definable through the Setup>Analog Outputs menu.
RTN	Ground	
V2	V +	
RTN	Ground	
V3	V +	
RTN	Ground	
V4	V +	
RTN	Ground	
Isolated Current Outputs		
I-1	I Out +	User definable through the Setup>Analog Outputs menu.
RTN	I Out -	
I-2	I Out +	
RTN	I Out -	
I-3	I Out +	
RTN	I Out -	

2.3.1.3 CONNECTING THE DIGITAL I/O EXPANSION BOARD OPTION

The connections on this board include three relay alarms, five digital outputs, and three isolated digital input controls. The **Relays** can be mapped to reflect various internal instrument conditions and states. The **Outputs** are isolated from the instrument and consist of open collector transistors with a common ground; they can be mapped to reflect various internal instrument conditions and states; they can be used to interface with devices that accept logic-level digital inputs, such as Programmable Logic Controllers (PLCs). The **Inputs** are also isolated but share the same ground as the Outputs; they will work with relays, open collectors, or 3.3 V – 24 V logic. Pull low to activate. DI1 and DI2 are fixed (not mappable) for remote zero and span calibrations. DI1 and DI2 are fixed (not mappable) for remote zero and span calibrations.

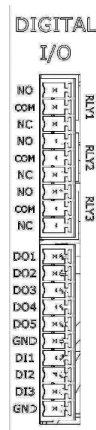

Figure 2-5. Digital I/O Connector Panel Option

Table 2-4. Digital Input/Output Pin Assignments

PIN	DESCRIPTION	
Relays		
NO	RLY1	Relay Alarms, user-configurable through the Setup>Digital Outputs menu.
COM		
NC		
NO	RLY 2	
COM		
NC		
NO	RLY 3	
COM		
NC		
Digital Outputs and Inputs		
DO1	Digital Outputs mappable in the Setup>Digital Outputs menu, and viewable in the Utilities>Diagnostics>Digital Outputs menu	
DO2		
DO3		
DO4		
DO5		
GND	Ground	
DI1	Digital Input1 = Remote Zero Cal	
DI2	Digital Input2 = Remote Span Cal	
DI3	(Digital Input3 not used)	
DI3	View status in Utilities>Diagnostics>Digital Inputs menu	
GND	Ground	

2.3.1.4 CONNECTING COMMUNICATIONS INTERFACES

ETHERNET CONNECTION

For network or Internet communication with the analyzer, connect an Ethernet cable from the analyzer's rear panel Ethernet interface connector to an Ethernet port. Although the analyzer is shipped with DHCP enabled by default, it should be manually configured with a static IP address.

SERIAL CONNECTION

Received from the factory, the analyzer COM port is set up for RS-232 communications with data communication equipment (DCE). This port can be reconfigured for RS-232 communications with data terminal equipment (DTE) (view/edit software settings Table 2-15).



WARNING – Electrical Shock Hazard

Disconnect all power before performing any operation that requires entry into the interior of the analyzer. Contact Technical Support (Section 5.10) before reconfiguring the internal serial connector.

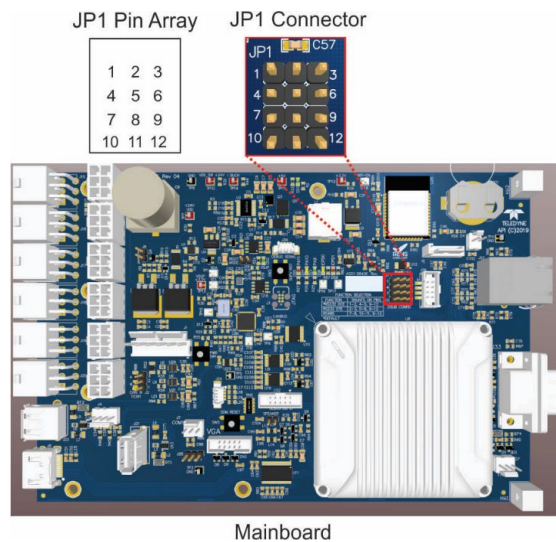

Figure 2-6. Mainboard JP1 Location and Pin Arrangements

Table 2-5. JP1 Configurations for Serial Communication

Function	Jumpers	DSub Pins	
		2	3
DCE RS232 (default)	1-2, 4-5, 9-12	232Tx	232Rx
DTE RS232	2-3, 5-6, 9-12	232Rx	232Tx

View/edit the Communications parameters in the Setup>Comm>COM1 menu.

RS-232

- **Baud rate:** 115200 bits per second (baud)
- **Data Bits:** 8 data bits with 1 stop bit
- **Parity:** None

2.3.2 PNEUMATIC CONNECTIONS

This Section provides not only pneumatic connection information, but also important information about the gases required for accurate calibration. Pneumatic flow diagrams are shown in Section 2.3.3. Calibration instructions are provided in Section 4.

Before making the pneumatic connections, carefully note the following cautionary and special messages:

CAUTION – General Safety Hazard



- Ozone (O₃) is a toxic gas. Do not vent calibration gas or sample gas into enclosed areas.
- Obtain a Safety Data Sheet (SDS) for this material. Read and rigorously follow the safety guidelines described there.
- Sample and calibration gases should only come into contact with PTFE (Teflon), FEP, or glass.
- Venting should be outside the shelter or immediate area surrounding the instrument.
- It is important to conform to all safety requirements regarding exposure to O₃.

ATTENTION

COULD DAMAGE INSTRUMENT AND VOID WARRANTY

Maximum Pressure:

Ideally the maximum pressure of any gas at the sample inlet should equal ambient atmospheric pressure and should **NEVER** exceed 1.5 in-hg above ambient pressure.

Venting Pressurized Gas:

In applications where any gas (span gas, zero air supply, sample gas is) received from a pressurized manifold, a vent must be provided to equalize the gas with ambient atmospheric pressure before it enters the analyzer to ensure that the gases input do not exceed the maximum inlet pressure of the analyzer, as well as to prevent back diffusion and pressure effects. These vents should be:

- at least 0.2m long
- no more than 2m long
- vented outside the shelter or immediate area surrounding the instrument.

Dust Plugs:

Remove dust plugs from rear panel exhaust and supply line fittings before powering on/operating instrument. These plugs should be kept for reuse in the event of future storage or shipping to prevent debris from entering the pneumatics.



IMPORTANT

LEAK CHECK

Run a leak check once the appropriate pneumatic connections have been made; check all pneumatic fittings for leaks using the procedures defined in Section 5.6.3.

See Figure 2-2 and Table 2-2 for the location and descriptions of the various pneumatic inlets/outlets referenced in this section.

2.4.1.1 IMPORTANT INFORMATION ABOUT CALIBRATION GASES

Zero air and span gas are required for accurate calibration.

ZERO AIR

Zero air is a gas that is similar in chemical composition to the earth's atmosphere but scrubbed of all components that might affect the analyzer's readings. If your analyzer is equipped with an Internal Zero Span (IZS) or an external zero air scrubber option, it is capable of creating zero air. For analyzers without an IZS or external zero air scrubber option, a zero air generator such as the Teledyne API Model T701 can be used.

CALIBRATION (SPAN) GAS

Span gas is specifically mixed to match the chemical composition of the type of gas being measured at near full scale of the desired measurement range. Because ozone (O_3) quickly breaks down into molecular oxygen (O_2), this calibration gas cannot be supplied in precisely calibrated bottles like other gases.

- If the N400 analyzer is not equipped with the optional internal zero air generator (IZS), an external O_3 generator capable of supplying accurate O_3 calibration mixtures must be used.
- Also, some applications, such as EPA monitoring, require multipoint calibration checks where Span gas of several different concentrations is needed.
- In either case, we recommend using a Gas Dilution Calibrator such as a TAPI Model T700 with internal photometer option.

In the case of O_3 measurements made with the Model N400 photometric ozone analyzer, it is recommended that you use a span gas with an O_3 concentration equal to 90% of the reporting range for your application.

EXAMPLE:

- If the application is to measure between 0 ppm and 500 ppb, an appropriate span gas would be 450 ppb.
- If the application is to measure between 0 ppb and 1000 ppb, an appropriate span gas would be 800 ppb.

2.3.2.1 PNEUMATIC CONNECTIONS: BASIC CONFIGURATION

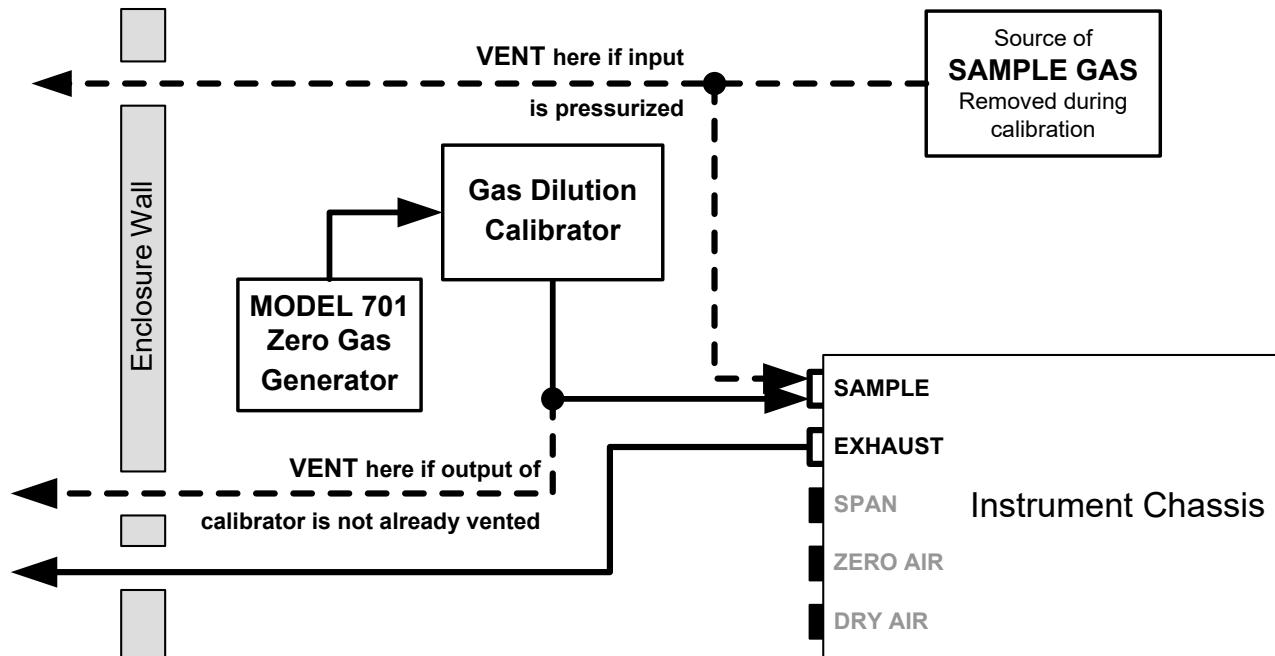

Figure 2-7. Gas Line Connections for the N400 Analyzer – Basic Configuration

For the Model N400 photometric ozone analyzer in its basic configuration (i.e. without the optional internal zero air source or valves), attach the following pneumatic lines:

SAMPLE GAS SOURCE

Attach a sample inlet line to the **SAMPLE** inlet port.

- Sample Gas pressure must equal ambient atmospheric pressure (1.0 psig)
- In applications where the sample gas is received from a pressurized manifold, a vent must be placed on the sample gas line. This vent line must be:
 - At least 0.2m long
 - No more than 2m long
 - Vented outside the shelter or immediate area surrounding the instrument

CALIBRATION GAS SOURCES

The source of calibration gas is also attached to the **SAMPLE** inlet, but only when a calibration operation is actually being performed.

EXHAUST OUTLET

Attach an exhaust line to the analyzer's **EXHAUST** outlet fitting. The exhaust line should be:

- PTFE tubing; minimum O.D. ¼";
- A maximum of 10 meters long;
- Vented outside the analyzer's enclosure.

LEAK CHECK

Once the appropriate pneumatic connections have been made, check all pneumatic fittings for leaks using the procedures defined in Section 5.6.3.

2.3.2.2 PNEUMATIC CONNECTIONS: ZERO/SPAN (Z/S) OPTION

For a Model N400 photometric ozone analyzer with the optional zero/span valves, attach the pneumatic lines as described in this section.

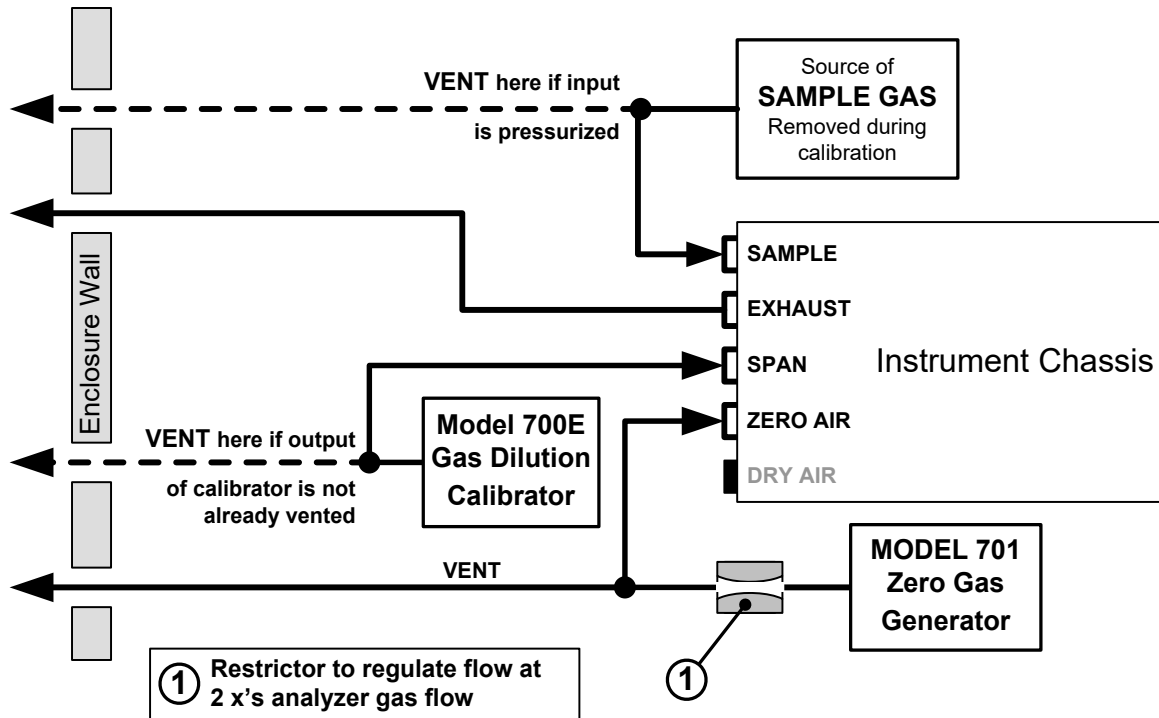

Figure 2-8. Gas Line Connections for the N400 Analyzer with Zero/Span Valve Option

The instrument's zero air and span gas flow rate required for this option is 800 cc/min, however, the US EPA recommends that the cal gas flow rate be at least 1600 cc/min.

SAMPLE GAS SOURCE

Attach a sample inlet line to the **SAMPLE** inlet fitting.

- Sample Gas pressure must equal ambient atmospheric pressure (1.0 psig)
- In applications where the sample gas is received from a pressurized manifold, a vent must be placed on the sample gas line. This vent line must be:
 - At least 0.2m long
 - No more than 2m long
 - Vented outside the shelter or immediate area surrounding the instrument



CALIBRATION (SPAN) GAS SOURCE

Attach a gas line from the source of calibration gas (e.g. a Teledyne API T700 Dynamic Dilution Calibrator) to the **SPAN** inlet.

- Span gas can be generated by a M700E Mass Flow Calibrator equipped with a Photometer Option or an M703E UV Photometric Ozone Calibrator.

ZERO AIR

Attach a gas line from the source of zero air (e.g. a Teledyne API T701 zero air Generator) to the **ZERO AIR** inlet.

- Zero air can be supplied by the API T701 zero air generator.
- A restrictor is required to regulate the gas flow at 2x the gas flow of the analyzer.

VENTING

In order to prevent back diffusion and pressure effects, both the span gas and zero air supply lines should be:

- Vented outside the enclosure
- Not less than 2 meters in length
- Not greater than 10 meters in length

EXHAUST OUTLET

Attach an exhaust line to the **EXHAUST** outlet fitting. The exhaust line should be:

- ¼" PTFE tubing
- A maximum of 10 meters long
- Vented outside the N400 analyzer's enclosure



CAUTION – Ozone Exposure Risk

Venting should be outside the shelter or immediate area surrounding the instrument and conform to all safety requirements regarding exposure to O₃.

Once the appropriate pneumatic connections have been made, check all pneumatic fittings for leaks using the procedures defined in Section 5.6.4).

2.3.2.3 PNEUMATIC CONNECTIONS: INTERNAL ZERO/SPAN (IZS) OPTION

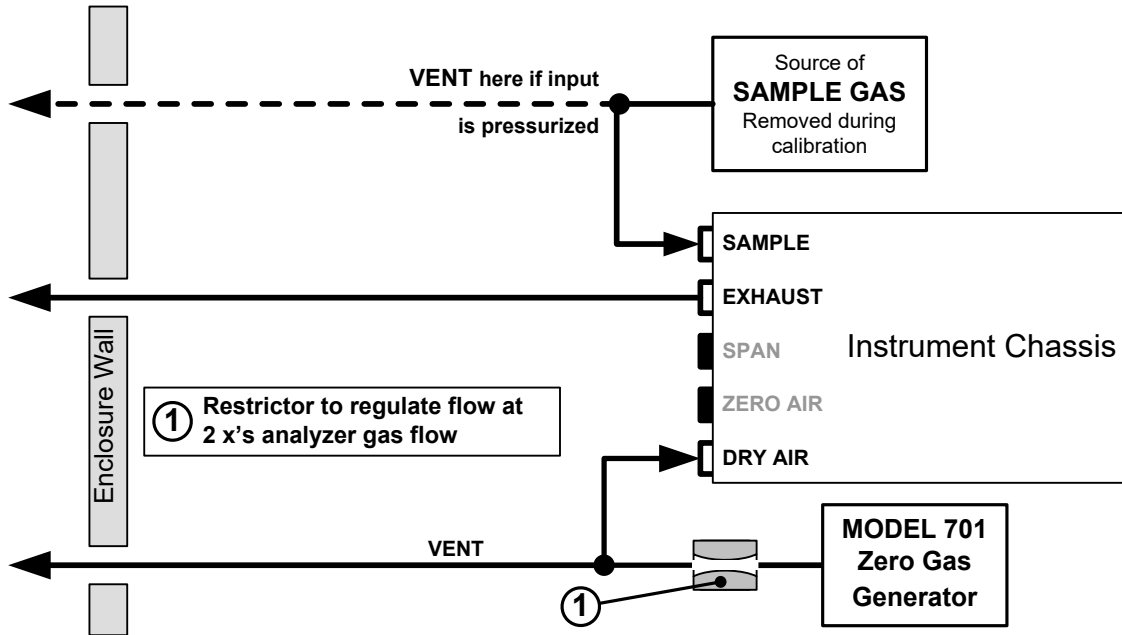

Figure 2-9. Gas Line Connections for the N400 Analyzer with IZS Option

SAMPLE GAS SOURCE

Attach a sample inlet line to the SAMPLE inlet port.

- Sample Gas pressure must equal ambient atmospheric pressure (1.0 psig)
- In applications where the sample gas is received from a pressurized manifold, a vent must be placed on the sample gas line. This vent line must be:
 - At least 0.2m long
 - No more than 2m long
 - Vented outside the shelter or immediate area surrounding the instrument

ZERO AIR SOURCE

Attach a gas line from the source of zero air (e.g., a Teledyne API T701 zero air Generator) to the **DRY AIR** inlet.

- The gas from this line will be used internally as zero air and as source air for the internal O₃ generator

EXHAUST OUTLET

Attach an exhaust line to the EXHAUST outlet fitting. The exhaust line should be:

- PTFE tubing; minimum O.D ¼”;
- A maximum of 10 meters long;
- Vented outside the analyzer’s enclosure.

LEAK CHECK

Once the appropriate pneumatic connections have been made, check all pneumatic fittings for leaks using the procedures defined in Section 5.6.3.

2.3.2.4 PNEUMATIC CONNECTIONS: AMBIENT AIR MONITORING IN SAME ROOM

In this application it is often preferred that the sample gas and the source gas for the O₃ generator and internal zero air be the same chemical composition.

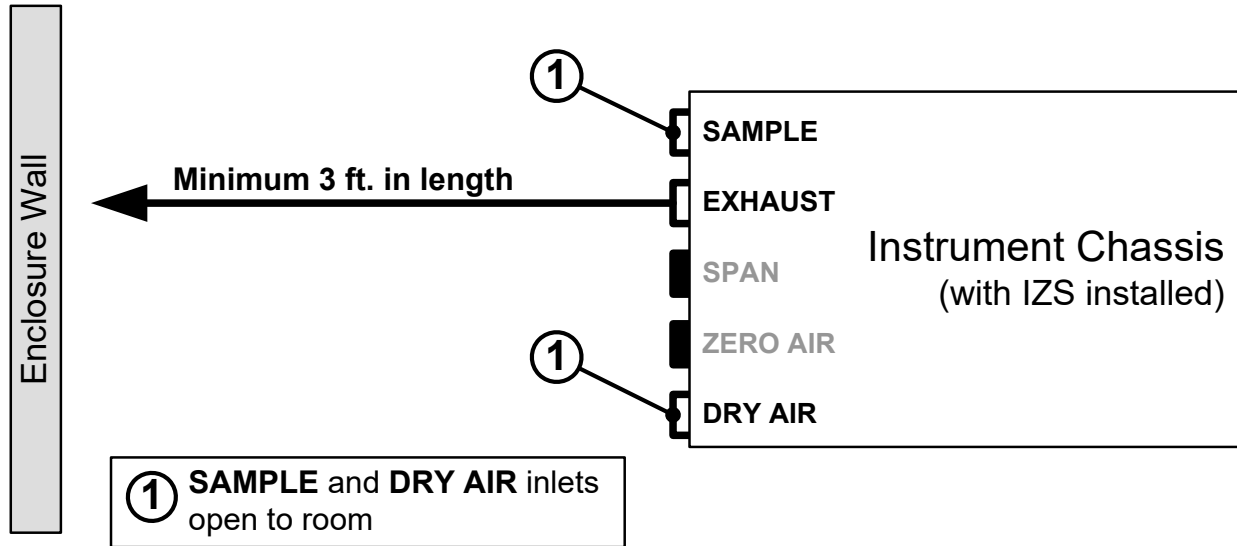

Figure 2-10. Gas Line Connections when the N400 Analyzer is Located in the Room Being Monitored

SAMPLE GAS AND DRY AIR SOURCES

For instruments located in the same room being monitored, there is no need to attach the gas inlet lines to the **SAMPLE** inlet or the **DRY AIR** inlet.

EXHAUST OUTLET

Attach an exhaust line to the **EXHAUST** outlet fitting. The end of the exhaust line should be at least 2 feet from the rear panel of the instrument in order to prevent sampling its own exhaust (resulting in low readings).

LEAK CHECK

Once the appropriate pneumatic connections have been made, check all pneumatic fittings for leaks using the procedures defined in Section 5.6.3.

2.3.2.5 PNEUMATIC CONNECTIONS: AMBIENT AIR MONITORING IN REMOTE LOCATIONS

In this application it is often preferred that the Sample gas and the source gas for the O₃ generator and internal zero air be the same chemical composition.

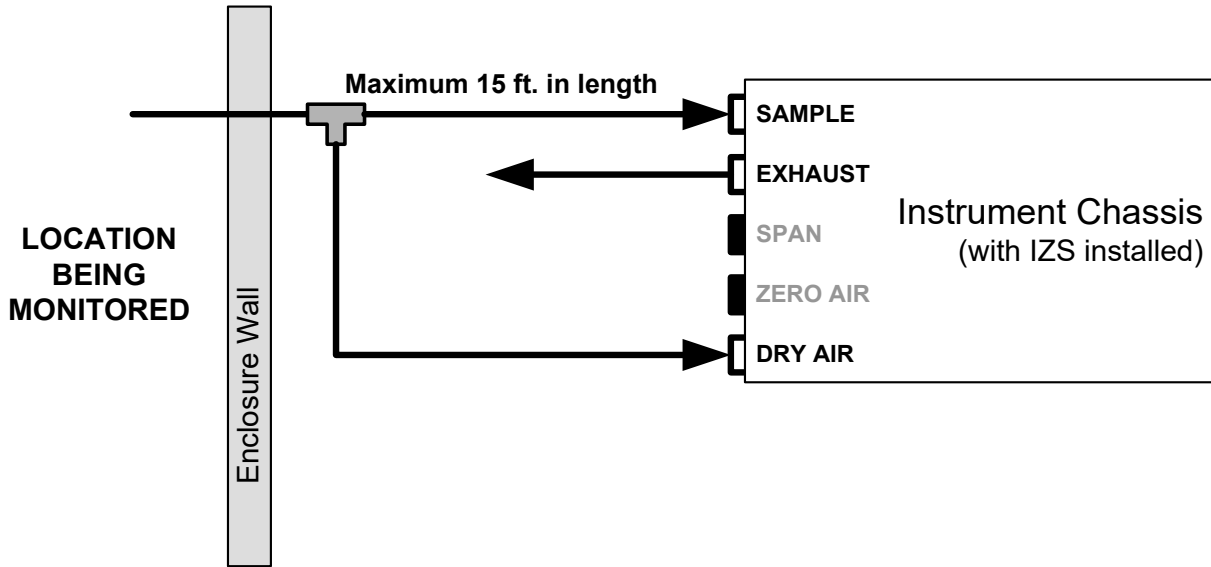

Figure 2-11. Gas Line Connections when the N400 Analyzer is Monitoring a Remote Location

SAMPLE GAS SOURCE

Attach a sample inlet line leading from the room being monitored to the **SAMPLE** inlet fitting.

DRY AIR SOURCE

Attach a gas line leading from the room being monitored to the **DRY AIR** inlet port. This can be a separate line or, as shown above (Figure 2-11) in the same line with a T-fitting.

EXHAUST OUTLET

No outlet line is required for the exhaust port of the instrument.

LEAK CHECK

Once the appropriate pneumatic connections have been made, check all pneumatic fittings for leaks using the procedures defined in Section 5.6.3.

2.3.3 PNEUMATIC FLOW DIAGRAMS

This Section shows the pneumatic flow diagrams for basic and Internal Zero Span (IZS) configurations.

2.3.3.1 PNEUMATIC FLOW: BASIC CONFIGURATION

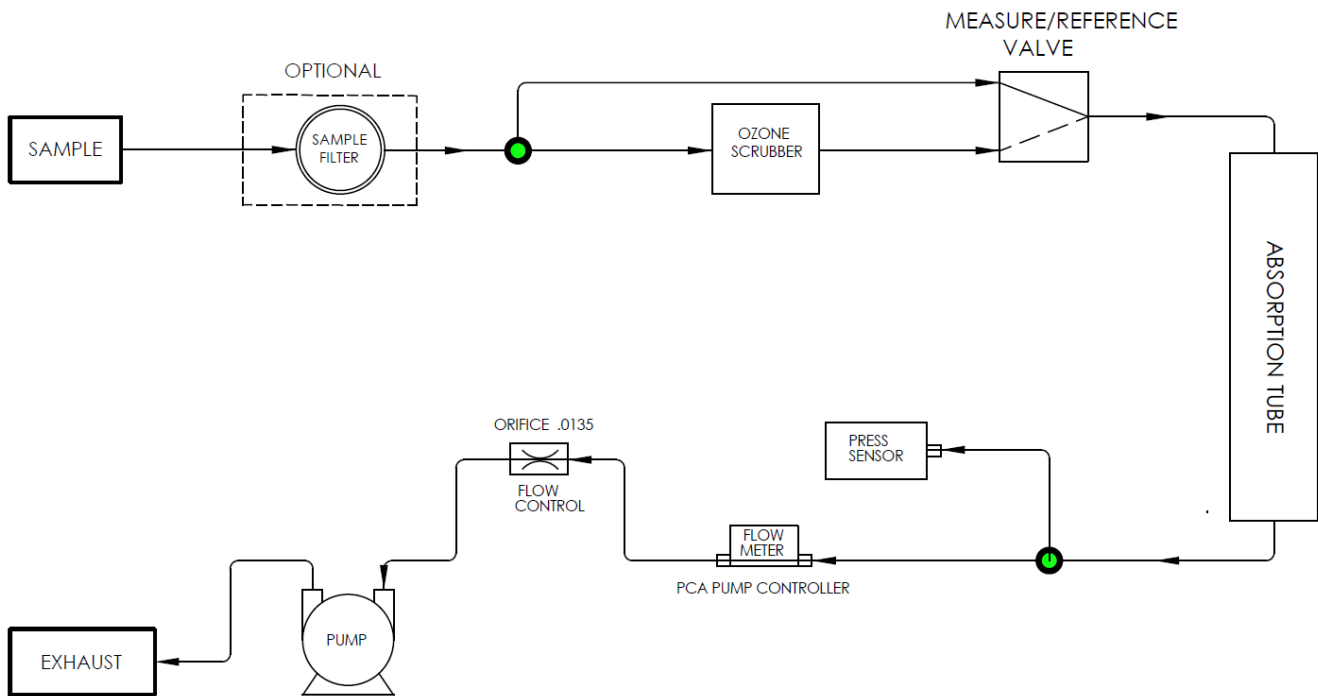

Figure 2-12. N400 Pneumatic Diagram – Basic Unit

2.3.3.2 PNEUMATIC FLOW: ZERO/SPAN (ZS) VALVE OPTION

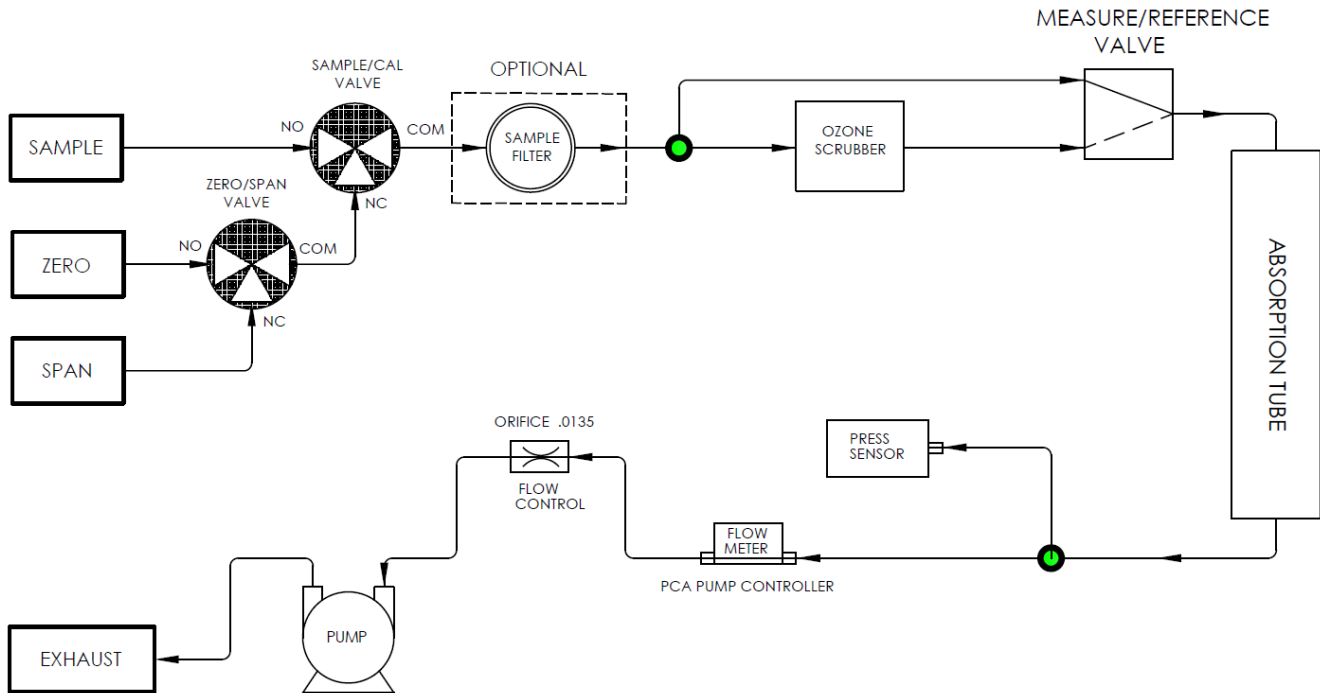

Figure 2-13. N400 Pneumatic Diagram with Zero/Span (ZS) Option

Table 2-6. Operating States for Zero/Span Valve Option

Mode	Valve	Condition
SAMPLE	Sample/Cal	Open to SAMPLE inlet
	Zero/Span	Open to ZERO AIR inlet
ZERO CAL	Sample/Cal	Open to ZERO/SPAN valve
	Zero/Span	Open to ZERO AIR inlet
SPAN CAL	Sample/Cal	Open to ZERO/SPAN valve
	Zero/Span	Open to SPAN GAS inlet

The state of the Sample/Cal valves can be controlled:

- Manually via the analyzer’s front panel;
- By activating the instrument’s AutoCal feature (See Section 4.3);
- Remotely by using the External Digital I/O Control Inputs (See Section 4.2.2.1)

2.3.3.3 PNEUMATIC FLOW: INTERNAL ZERO/SPAN (IZS) VALVE OPTION

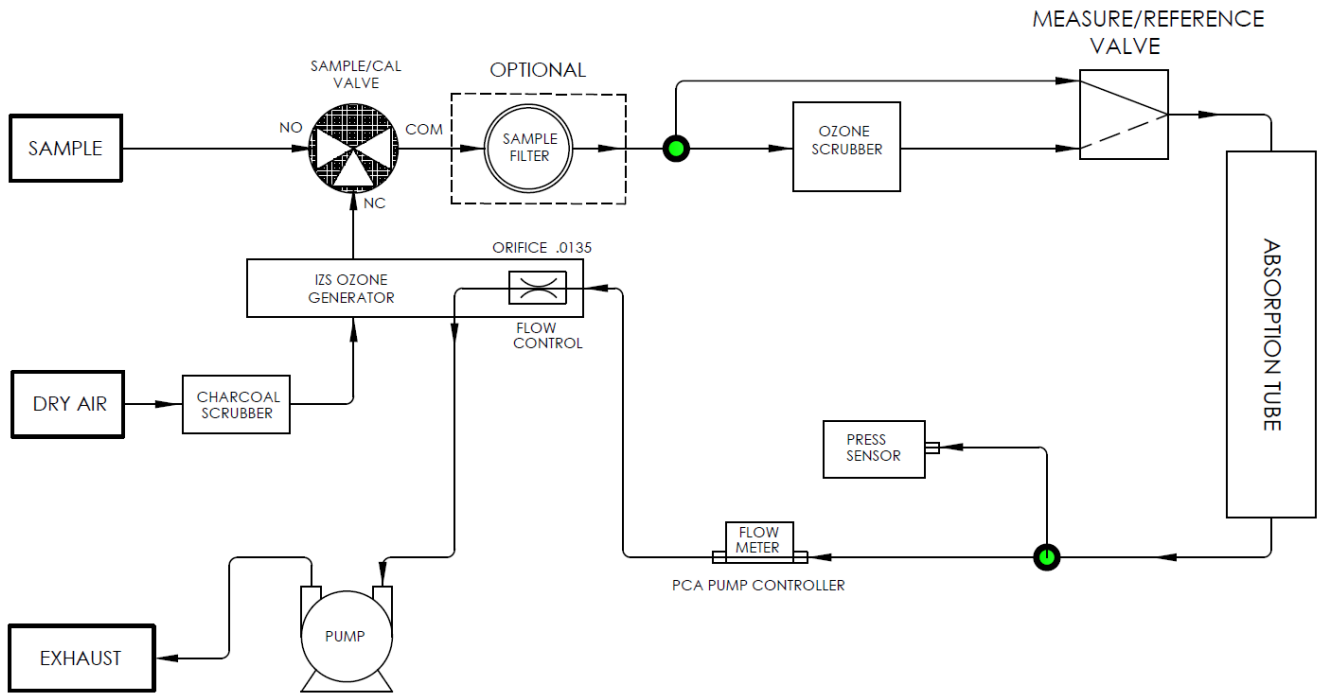

Figure 2-14. N400 Pneumatic Diagram with Internal Zero/Span (IZS) Option

Table 2-7. Operating States for Internal Zero/Span Valve Option

Mode	Valve	Condition
SAMPLE	Sample/Cal Valve	Open to SAMPLE inlet
	Ozone Generator	OFF
ZERO CAL	Sample/Cal Valve	Open to Ozone Generator
	Ozone Generator	OFF
SPAN CAL	Sample/Cal Valve	Open to Ozone Generator
	Ozone Generator	ON at intensity level set by user

The state of the Sample/Cal valves can be controlled:

- Manually via the analyzer's front panel
- By activating the instrument's AutoCal feature (See Section 4.3)
- Remotely by using the External Digital I/O Control Inputs (see Section 4.2.2.1)

2.3.4 STARTUP, FUNCTIONAL CHECKS, AND INITIAL CALIBRATION

We recommend reading Section 6 to become familiar with the principles of operation.

When the instrument is first started (Section 2.3.4.1, check its functionality (Section 2.3.4.3) and run an initial calibration (Section 4). Section 2.4 introduces the menu system, and Section 2.5 provides setup/customization instructions.

CAUTION!



If the presence of ozone is detected at any time, power down the instrument and contact Teledyne API Technical Support as soon as possible:

+1 800-324-5190 or email: api-techsupport@teledyne.com

2.3.4.1 STARTUP

Upon initial startup, a sequence of status screens (Figure 2-15) appear prior to the Home page (Figure 2-16).

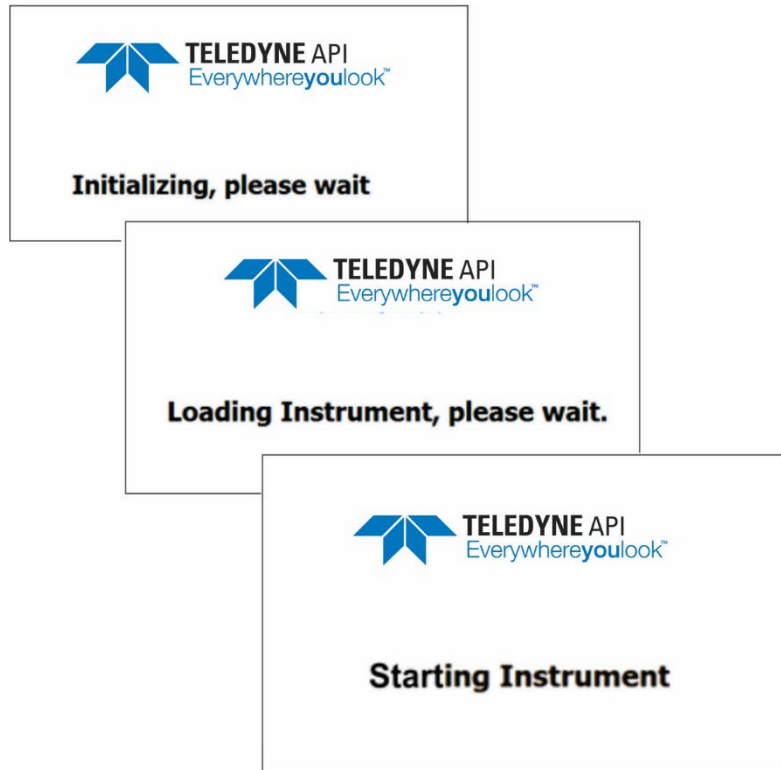

Figure 2-15. Status Screens at Startup

Upon any startup, this instrument should warm up for at least one hour to allow components to stabilize and to provide reliable measurements.

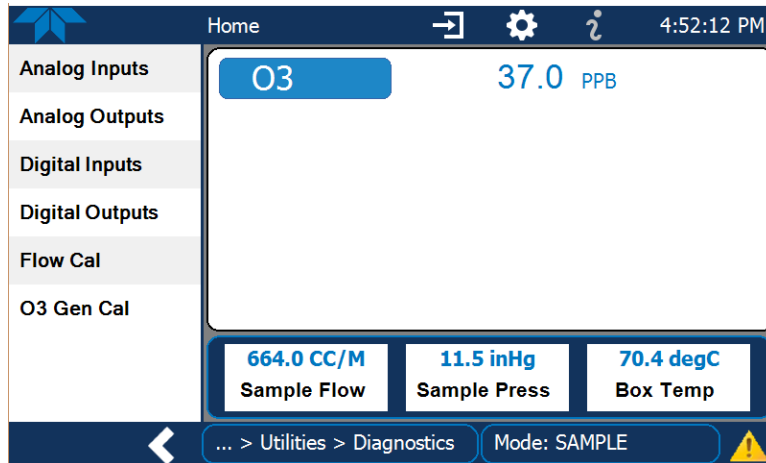

Figure 2-16. Home Page Example

2.3.4.2 ALERTS: WARNINGS AND OTHER MESSAGES

Because internal temperatures and other conditions may be outside the specified limits during the analyzer’s warm-up period, the software will suppress most Alerts for 30 minutes after power up. The Alerts page (Figure 2-17) shows the status of any active warning conditions or user-configured Events. (Section 2.4.3 provides more detailed information about Alerts, and Section 2.5.2 addresses Events).

Alerts can be viewed and cleared via either the Alerts menu or the Alerts shortcut (Caution symbol, bottom right corner of the screen). Although these alerts can be cleared from the Active Alerts page, a history of all alerts remains in the Utilities>Alerts Log page.

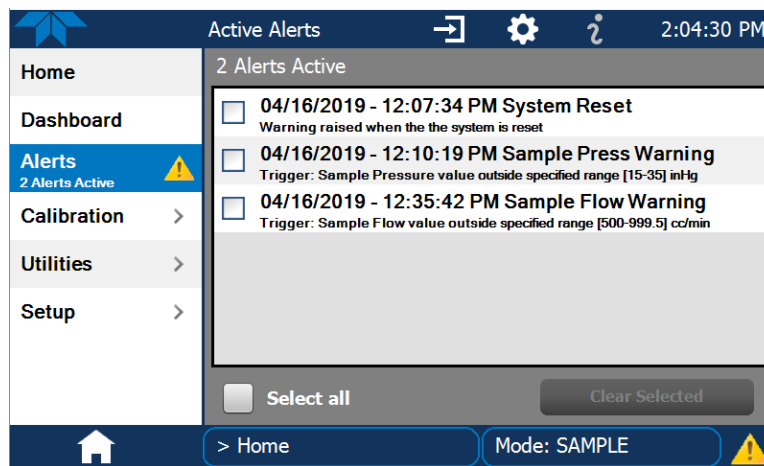

Figure 2-17. Viewing Active Alerts Page

If Alerts about warning conditions persist after the warm-up period or after being cleared, investigate their cause using the troubleshooting guidelines in Section 5.7.

2.3.4.3 FUNCTIONAL CHECKS

After warm-up, verify that the software properly supports any hardware options that are installed (Setup>Instrument menu), and that the instrument is functioning within allowable operating parameters. Check the Dashboard page against the instrument’s Final Test and Validation Data sheet, which lists these values as they appeared before the instrument left the factory. (If any functional parameters are not displayed, configure the Dashboard through the Setup>Dashboard menu to add them; see Section 2.4.2).

These functions are also useful tools for diagnosing problems (information provided in Section 5.7.2).

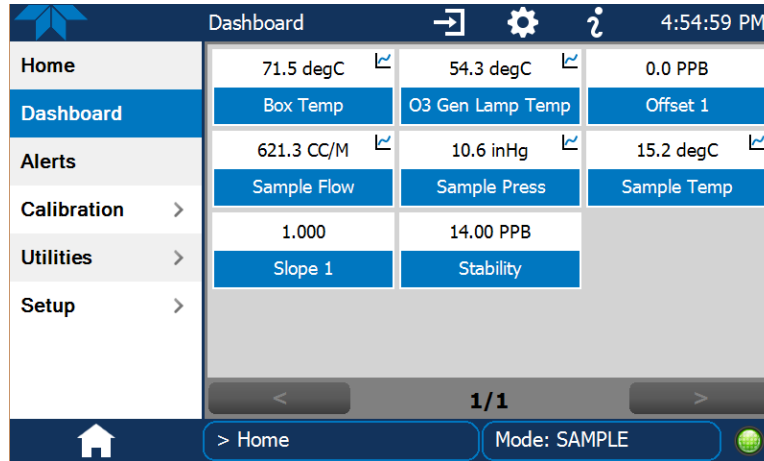

Figure 2-18. Sample Dashboard Page

2.3.4.4 INITIAL CALIBRATION

Before operation begins, the analyzer requires zero and span calibrations for the location in which it will perform any of the gas analyses. Also, any time an analyzer is moved or its configuration changed, it must undergo a calibration check. The method for performing a calibration or a basic calibration check differs slightly depending on whether or not any of the available internal zero air or valve options are installed. Follow the appropriate calibration instructions in Section 4.



2.4 MENU OVERVIEW

Table 2-8 describes the main menus and provides cross-references to the respective sections with configuration details.

Table 2-8. Menu Overview

MENU	DESCRIPTION	LOCATION	
Home	View and plot concentration readings and other selectable parameter values (Figure 2-20).	Section 2.4.1	
Dashboard	View user-selected parameters and their values, some of which can be displayed in a live-plot graph (Figure 2-21).	Section 2.4.2	
Alerts	View and clear active Alerts that were triggered by factory-defined Events as well as user-defined Events. (Active and past Alerts are recorded in the Utilities>Alerts Log).	Section 2.4.3	
Calibration	Run a multipoint calibration on O ₃ , and span and zero calibrations (if valve option installed).	Section 4	
Utilities	View logs, download data and firmware updates, copy configurations between instruments, and run diagnostics.	Section 2.4.5	
Setup	Configure a variety of features and functions through these submenus for customized operation.	Section 2.5	
	Datalogging	Track and record concentration and calibration data and selectable diagnostic parameters, the reports for which can be viewed in the Utilities>Datalog View menu (Section 2.4.5) and downloaded to a flash drive via the Utilities>USB Utilities menu (Section 2.4.5). Also, select configured Events (Section 2.5.2) and create customized triggers for data logging functions.	Section 2.5.1
	Events	Select parameters and define the conditions by which they are to be flagged and recorded in the Alerts log (Section 2.4.3) when they are triggered. Once configured, Events can be used to trigger Datalogs. (Section 2.5.1). Note that some Events are predefined and are not editable.	Section 2.5.2
	Dashboard	Monitor instrument functionality (Figure 2-18) via selectable parameters.	Section 2.5.3
	Auto Cal (with valve options)	When zero/span valve options installed, configure sequences for automatic calibration checks.	Section 4.3
	Vars	Manually adjust several software variables that define specific operational parameters.	Section 2.5.5
	Homescreen	Select up to three parameters to be displayed in the meters (Figure 2-19).	Section 2.5.6
	Digital Outputs (option)	Map the rear-panel digital outputs to a variety of signals present in the instrument to monitor the status of operating conditions or custom Events.	Section 2.5.7
	Analog Outputs (option)	Send user-selected parameter readings in the form of user-defined voltage or current loop signals as outputs to a strip chart recorder and/or the data logger.	Section 2.5.8
	Instrument	View product and system information, including list of options, if any; view network settings; view/adjust Date and Time settings*; and check for firmware updates when connected to a network that is connected to the Internet. *Time Zone change requires special procedures (Section 5.5).	Section 2.5.9
	Comm	View and configure network and serial communications.	Section 2.5.10

2.4.1 HOME PAGE

Figure 2-19 presents an orientation to the main display screen; Figure 2-20 shows that pressing the gas name or its concentration value or a meter below displays a live plot of their respective readings. Section 2.5.6 provides configuration instructions.

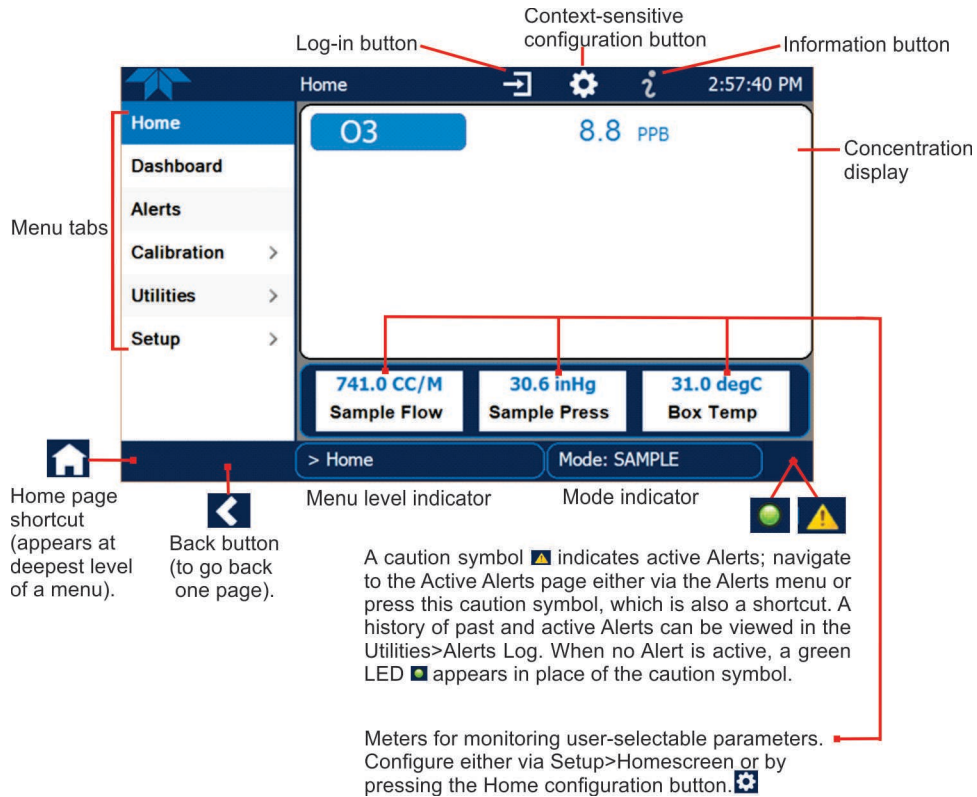
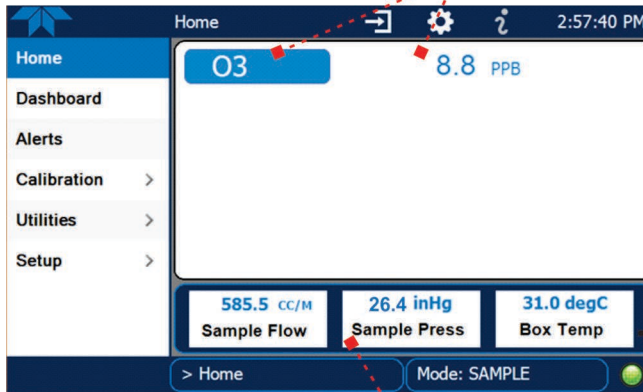
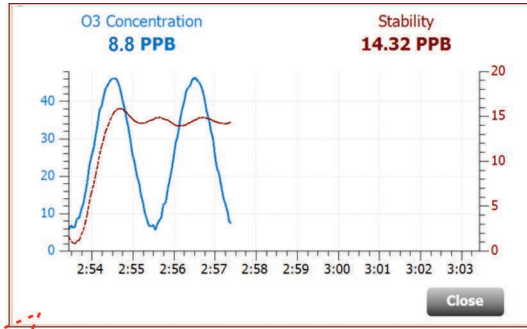

Figure 2-19. User Interface Orientation

Select either a gas name or its reading to display graph.



(Change parameters for display in these meters using Home configuration (gear icon)).

Select a meter to display graph.

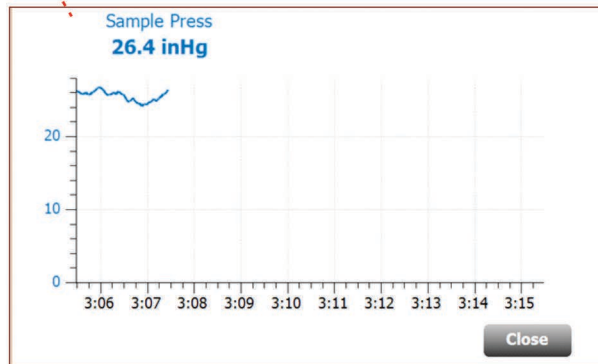
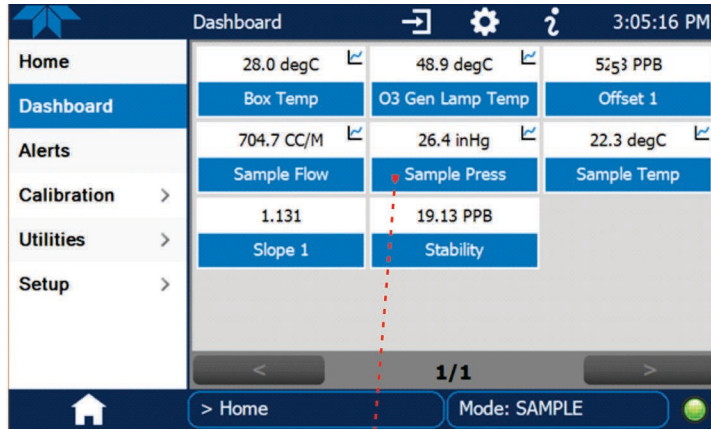

Figure 2-20. Concentration and Stability Graph (top) and Meter Graph (bottom)

2.4.2 DASHBOARD

The Dashboard displays an array of user-selectable parameters and their values (Section 2.5.3 provides configuration instructions). If there is a graphing icon in the upper right corner of a parameter, pressing that parameter displays a live plot of its readings as in Figure 2-21.



Select a graphable parameter in the Dashboard page to view a live plot.

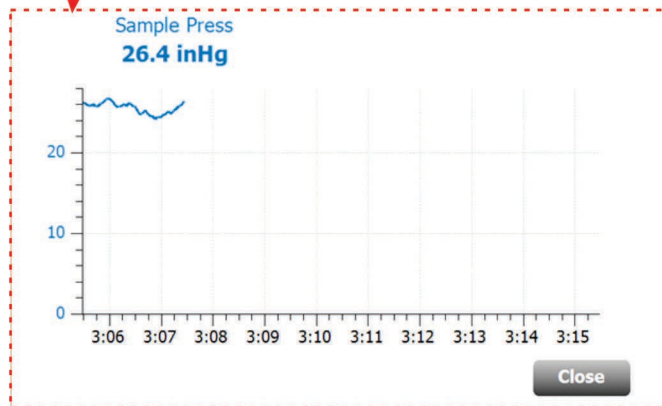

Figure 2-21. Dashboard Page

Several of the common parameters and their descriptions are presented in Table 2-9.



Table 2-9. Common Dashboard Parameters

PARAMETER	UNITS	DESCRIPTION
Box Temp	°C	The temperature inside the analyzer chassis.
O3 Offset	PPB	The Offset of the instrument as calculated during the last calibration activity.
O3 Slope	--	The Slope of the instrument as calculated during the last calibration activity.
O3 Stability	MV	Standard deviation of O ₃ Concentration readings. Data points are recorded every ten seconds. The calculation uses the last 25 data points.
Photo Lamp Temp	°C	The temperature of the UV Lamp in the Optical Bench.
Photo Meas	MV	The average UV Detector output during the MEASURE portion of the analyzer's measurement cycle.
Photo Ref	MV	The average UV Detector output during the REFERENCE portion of the analyzer's measurement cycle.
Pump Flow	CC/MIN	Sample Gas mass flow rate as measured by the Flow Sensor located between the Optical Bench and the Sample Pump.
Sample Pressure	IN-HG-A	The absolute pressure of the Sample Gas as measured by a solid-state pressure sensor.
Sample Temp	°C	The temperature of the gas inside the Sample Chamber.

2.4.3 ALERTS

Alerts are notifications triggered by specific criteria having been met by either factory-defined conditions (standard and not editable) or user-defined Events (Section 2.5.2). The Active Alerts page shows the status of any active warning conditions or Events that have been triggered.

When Alerts are triggered, a caution symbol appears in both the Alerts menu tab and in the bottom right corner of the software interface, which serves as a shortcut to the Alerts page from any other page. View a list of currently active Alerts by pressing either the Alerts menu on the Home screen or by pressing the Alerts shortcut (Figure 2-22).

While Alerts can be cleared from the Active Alerts page, they remain recorded in the Utilities>Alerts Log menu.

Navigate to the Active Alert page via the Alerts menu on Home screen.

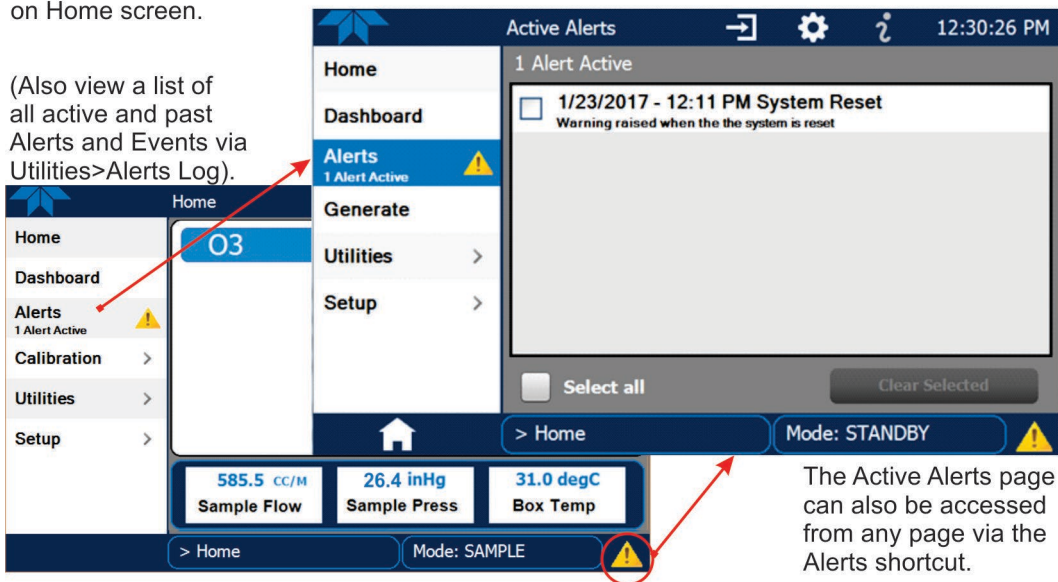

Figure 2-22. Navigating to the Active Alerts Page

Alerts can be configured as either latching (appears in Active Alerts screen when Event is triggered and must be cleared by the user) or non-latching (Active Alerts screen continuously updates based on the Event criteria, clearing on its own). See Section 2.5.2.

To clear Alerts from the Active Alerts page, either check individual boxes to choose specific Alerts, or check the Select All box to choose all Alerts, then press the Clear Selected button.

When all Alerts are cleared, the Alerts menu tab no longer shows the caution symbol, and a green LED replaces the caution symbol in the bottom right corner of the interface (Figure 2-23). However, Alerts can reappear if the conditions causing them are not resolved. For troubleshooting guidance, refer to Section 5.7.

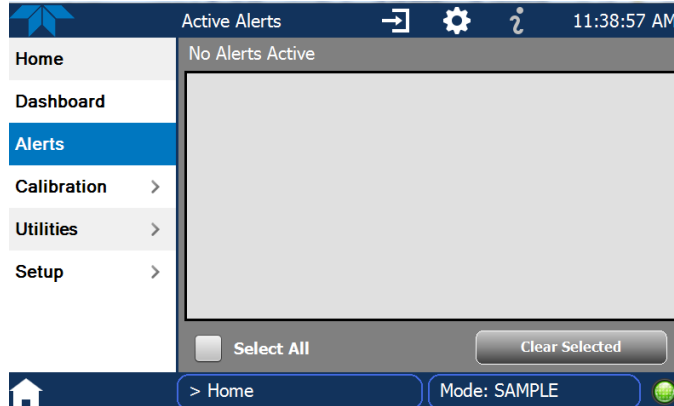

Figure 2-23. Active Alerts Cleared

Alerts and Events remain recorded in the Utilities>Alerts Log (Figure 2-24).

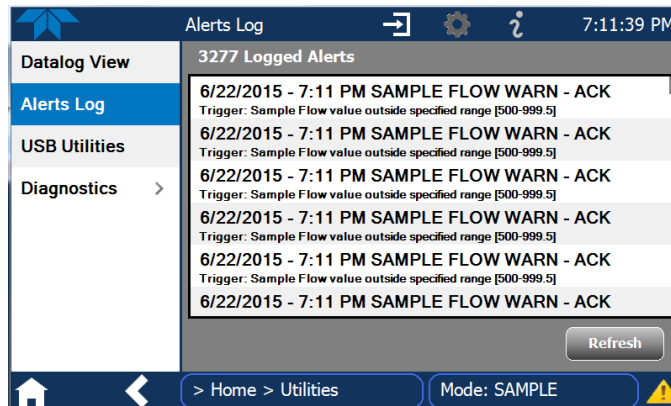

Figure 2-24. Utilities>Alerts Log of Active and Past Alerts and Events

2.4.4 CALIBRATION

The Calibration menu is used for multipoint calibrations as well as calibrations for zero and span with valve options, and for external calibration with valve options installed. Calibration procedures are presented in Section 4.

2.4.5 UTILITIES

The Utilities menu has a variety of functions as described next in Table 2-10.

Table 2-10. Utilities Submenu Descriptions

UTILITIES MENU	DESCRIPTION
Datalog View	Displays the data logs that were configured via the Setup>Data Logging menu. From this list a log can be selected and filters applied to view the desired data. (For details on setting up and running the Data Logger, see Section 2.5.1).
Alerts Log	Displays a history of alerts that are triggered by factory-defined and user-defined Events, such as warnings and alarms (See Section 2.5.2 for Events configuration).
USB Utilities	Serves multiple purposes using a flash drive connected to the instrument's front panel USB port: <ul style="list-style-type: none"> • download data from the instrument's Data Acquisition System (DAS), the Data Logger, to a flash drive (Section 2.5.1.3) • update firmware (Section 5.3) • transfer instrument configuration from/to other same-model instruments (Section 2.6) • download a basic operation functionality report (Section 5.3).
Diagnostics	Provides access to various submenus that facilitate troubleshooting, and to sensor calibrations.
Analog Inputs	Show raw Voltage of several internal analog input parameters. These can be logged in the internal data acquisition system (DAS) by configuring the Data Logger in the Setup menu.
Analog Outputs (option)	Show the Voltage or Current signals for the functions selected and configured in the Setup>Analog Outputs option menu. (Section 2.3.1.2 presents the rear panel connections).
Digital Inputs (option)	Show and change the ON/OFF state of specific, available features with the Digital I/O option.
Digital Outputs (option)	Show and change the ON/OFF state of user-defined (Setup>Digital Outputs menu) outputs and relays with the Digital I/O option.
Flow Cal	Use to calibrate the sample gas flow reading with actual flow measured by an external device. (See Section 4.5.2).
O3 Gen Cal (with IZS option)	Use to calibrate the O3 Generator when IZS option installed (Section 4.5.3).
Pressure Cal	Use for compensating for changes in atmospheric pressure (Section 4.5.1).

2.4.6 SETUP

The Setup menu is for configuring the instrument's various programmable features and functions. Section 2.5 provides details for the menus under Setup.

2.5 SETUP MENU: FEATURES/FUNCTIONS CONFIGURATION

Use the Setup menu to configure the instrument's software features, such as variables, outputs, display parameters, and the Data Logger, the instrument's internal data acquisition system (DAS). Once the setups are complete, the saved configurations can be downloaded to a USB drive through the Utilities>USB Utilities menu and uploaded to other instruments of the same model (Section 2.6).

2.5.1 SETUP>DATA LOGGING (DATA ACQUISITION SYSTEM, DAS)

The Data Logger can be configured to capture and store user-defined data, which then can be viewed in the Alerts page, if elected, as well as downloaded from the instrument to a USB flash drive or using NumaView™ Remote software for examination and analysis.

Figure 2-25 shows a new log; Figure 2-26 shows a sample existing log, which can be edited or deleted, and Figure 2-27 provides illustrated instructions for setting up a new log, with Sections 2.5.1.1 and 2.5.1.2 providing additional details.

To transfer captured instrument data to a flash drive see Section 2.5.1.3.

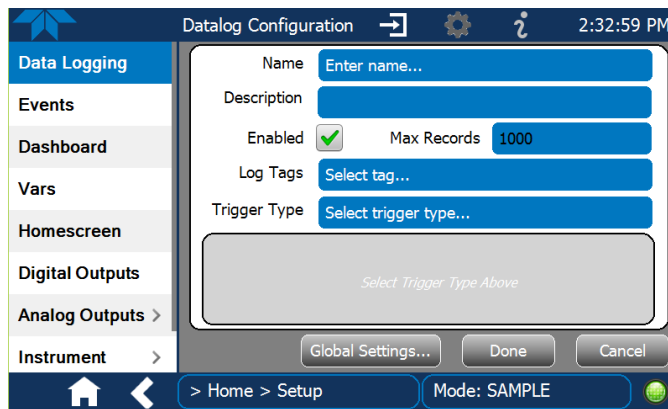

Figure 2-25. Datalog Configuration, New Log Page

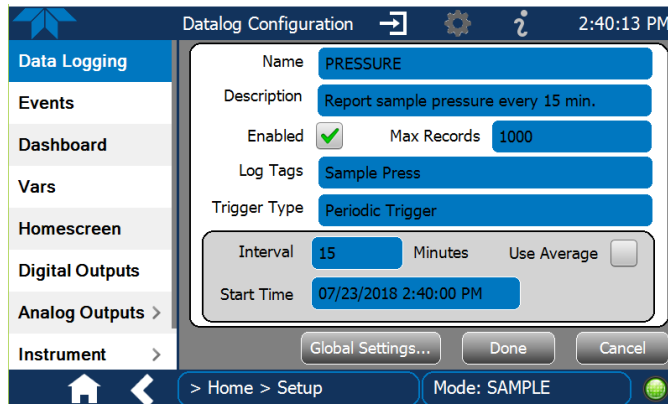
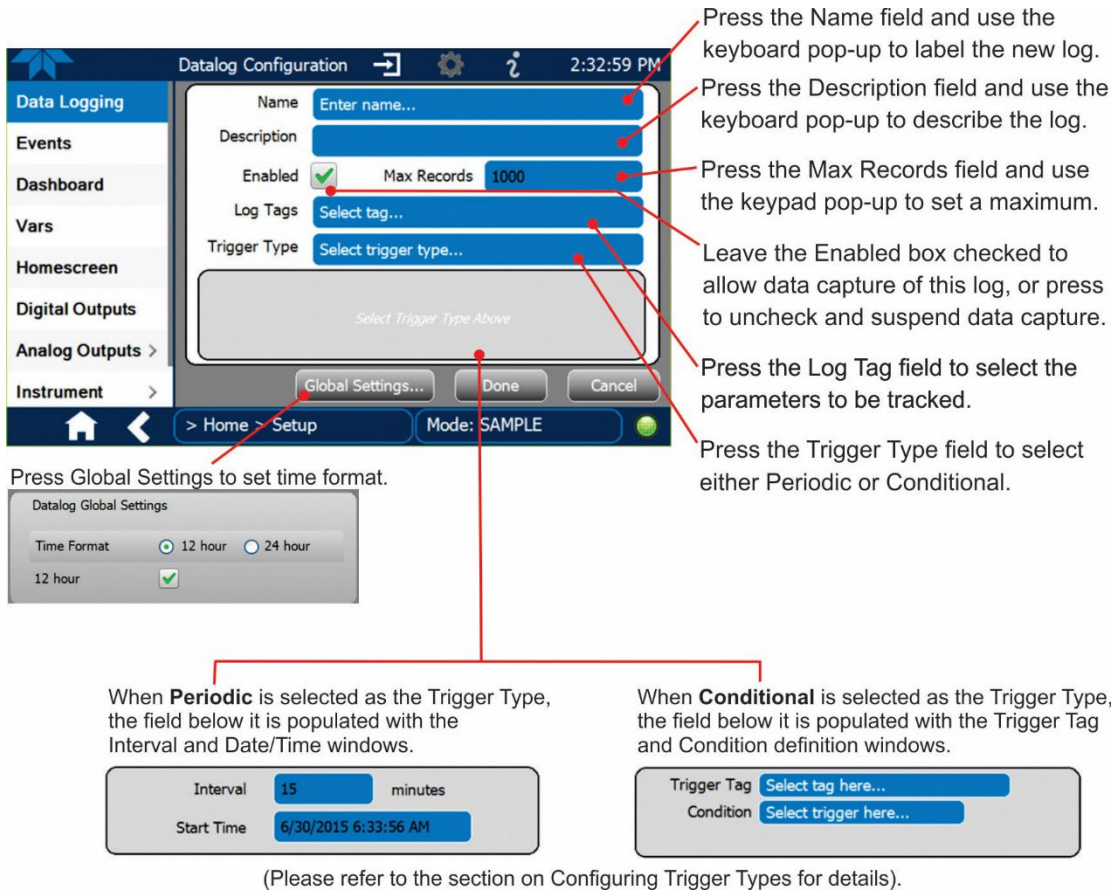

Figure 2-26. Datalog Configuration, Existing Log



Press the Name field and use the keyboard pop-up to label the new log.

Press the Description field and use the keyboard pop-up to describe the log.

Press the Max Records field and use the keypad pop-up to set a maximum.

Leave the Enabled box checked to allow data capture of this log, or press to uncheck and suspend data capture.

Press the Log Tag field to select the parameters to be tracked.

Press the Trigger Type field to select either Periodic or Conditional.

Press Global Settings to set time format.

Datalog Global Settings

Time Format 12 hour 24 hour

12 hour

When **Periodic** is selected as the Trigger Type, the field below it is populated with the Interval and Date/Time windows.

When **Conditional** is selected as the Trigger Type, the field below it is populated with the Trigger Tag and Condition definition windows.

Interval 15 minutes

Start Time 6/30/2015 6:33:56 AM

Trigger Tag Select tag here...

Condition Select trigger here...

(Please refer to the section on Configuring Trigger Types for details).

Figure 2-27. Creating a New Data Log

The parameters available in the list of Log Tags include the names of Events configured in the Events page (Section 2.5.2).

2.5.1.1 CONFIGURING TRIGGER TYPES: PERIODIC

The Periodic trigger is a timer-based trigger that is used to log data at a specific time interval. Periodic Trigger requires an interval that is set to number of minutes and a start time that is set to date and clock time.

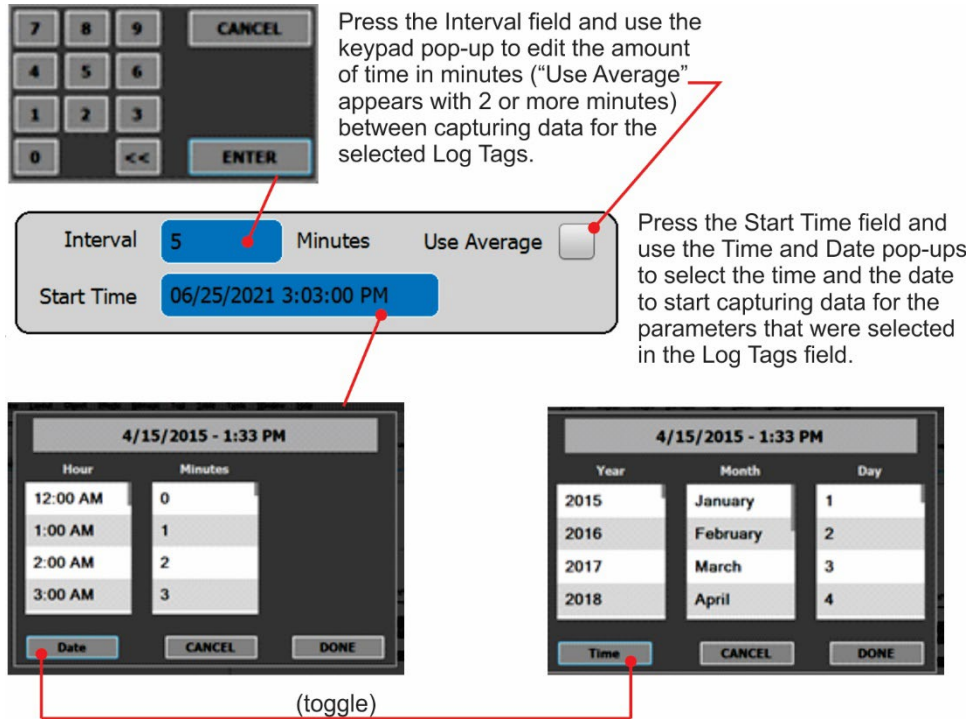

Figure 2-28. Datalog Periodic Trigger Configuration

2.5.1.2 CONFIGURING TRIGGER TYPES: CONDITIONAL

Conditional Trigger tracks/records data for user-selected parameters that meet specified conditions.

Press the Trigger Tag field and select a parameter to be tracked/logged. A default Condition associated with the selected Tag will populate the Condition field.

Press the Condition field to select a different choice from the condition list.

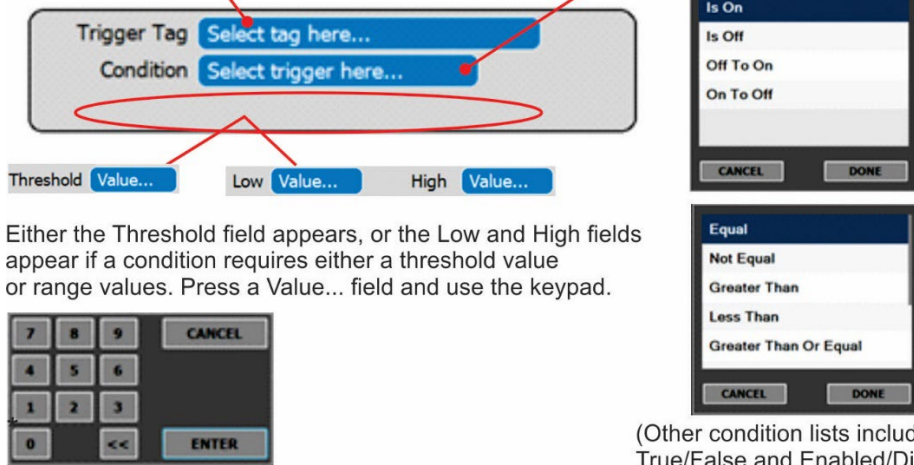

Figure 2-29. Datalog - Conditional Trigger Configuration

2.5.1.3 DOWNLOADING DAS (DATA ACQUISITION SYSTEM) DATA

To download DAS data collected by the Data Logger from the instrument to a flash drive, navigate to the Utilities>USB Utilities>DAS Download menu.

1. Insert a flash drive into a front panel USB port and wait for the Status field to indicate that the drive has been detected; available buttons will be enabled.

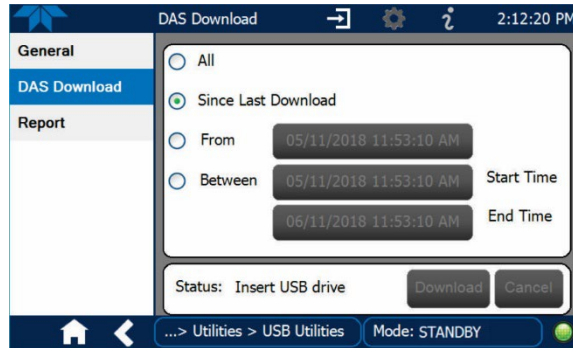

Figure 2-30. DAS Download Page

2. Select all or define a period from which to download the collected data.
3. Press the Download button, and when complete, as indicated in the Status field, press the Done button (changed from “Cancel”) and remove the flash drive.

2.5.2 SETUP>EVENTS

Events are occurrences that relate to any operating function, and are used to define the conditions that can be set to trigger Alerts (Section 2.4.3). Events can provide diagnostic information about the instrument, typically referred to as “Warnings”, or they can provide other information on instrument functionality, such as concentration alarms. Some Events are standard and not editable while others are user-configurable, described here. Existing Events are listed in the Events page (Figure 2-31) under the Setup menu.

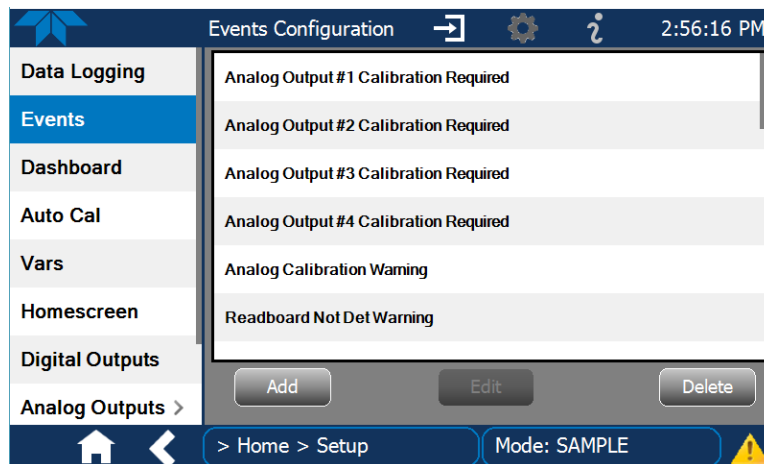

Figure 2-31. Events List

Access the Events Configuration page either from the Active Alerts page (Alerts Menu) by pressing the configuration button, or through the Home>Setup>Events menu (Figure 2-31). Press ADD to create a new Event (refer to Figure 2-32 for details), or select an existing Event to either Edit or Delete it (Figure 2-34).

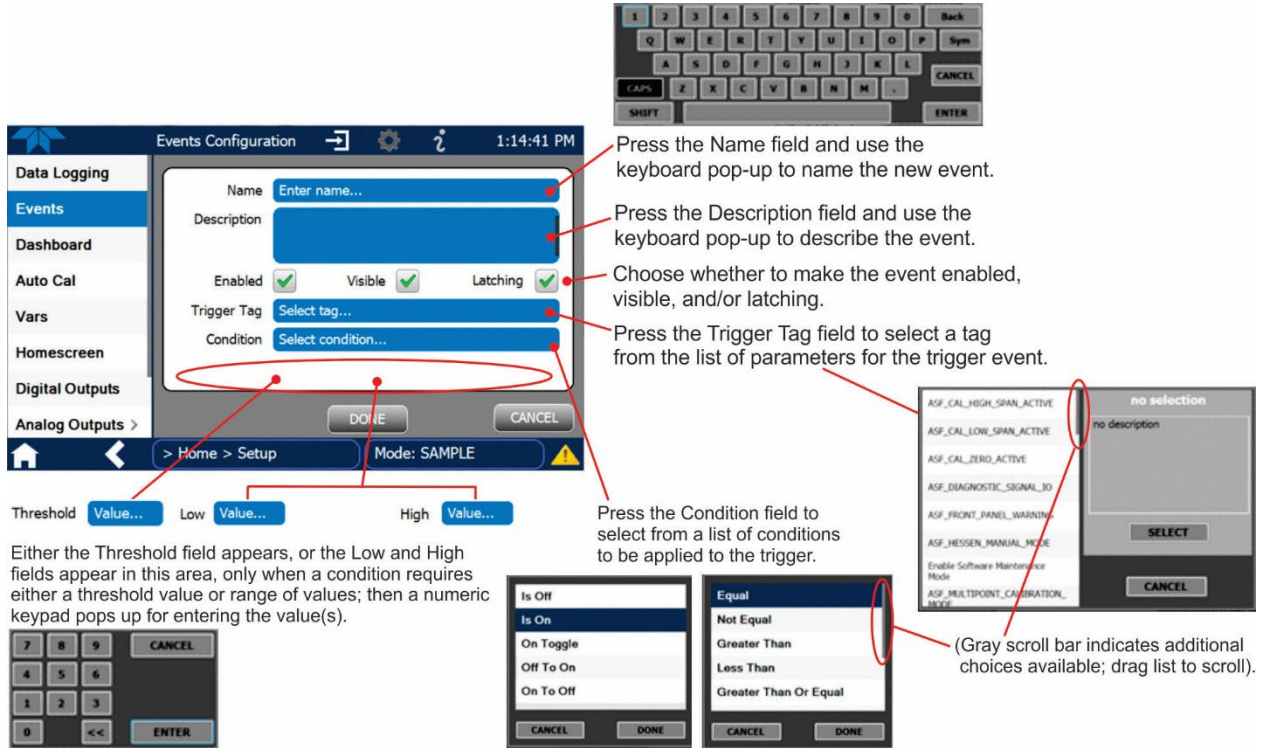

Figure 2-32. Event Configuration

- Enabled allows the choice of whether to track and record the Event (uncheck this box to “turn off” or deactivate the Event without deleting it). An Event must be enabled in order to use the Visible and the Latching options.
- Visible allows the choice of whether or not to display the Event in the Alerts page when it is triggered (it will still be recorded and can be viewed in the Utilities>Alerts Log). To use this option, the Event must be enabled.
- Latching allows the choice of whether or not to keep an Event visible even if the conditions that triggered it were to correct themselves. (Latching requires that the user interact with the Active Alerts screen to manually clear the Alert and internal Event state. Non-latching allows the entry in the Active Alerts screen and the internal Event state to continuously update based on the Event criteria, requiring no user interaction to clear the Alert or Event state).

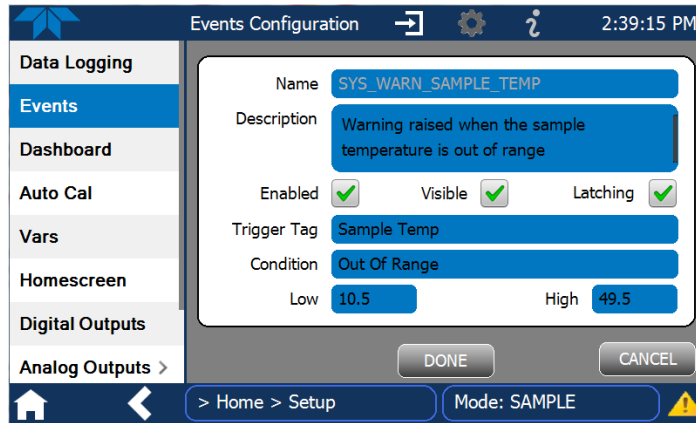

Figure 2-33. Configured Event Sample

2.5.2.1 EDITING OR DELETING EVENTS

Select an Event from the list (Figure 2-31) and press the Edit button to view or edit the details (Figure 2-33), or press the Delete button to delete the Event.

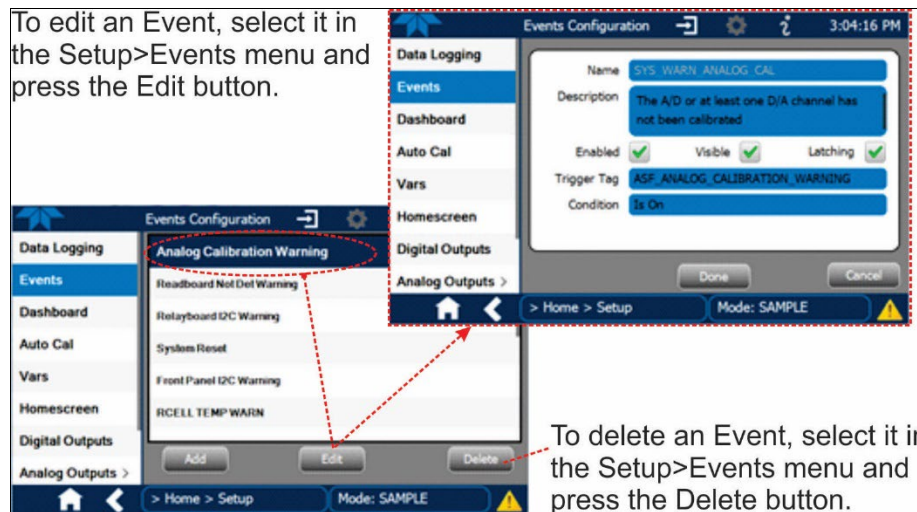

Figure 2-34. Edit or Delete an Event

Note

Some default Events that cannot be entirely deleted may return after reboot.

2.5.2.2 USING EVENTS AS TRIGGERS FOR DATA LOGGING

Events can also be used to create customized triggers for data logging functions. The name entered in the Name field of the Events Configuration page will appear in the list of Log Tags of the Datalog Configuration page. The Data Logger is presented in Section 2.5.1.

2.5.3 SETUP>DASHBOARD

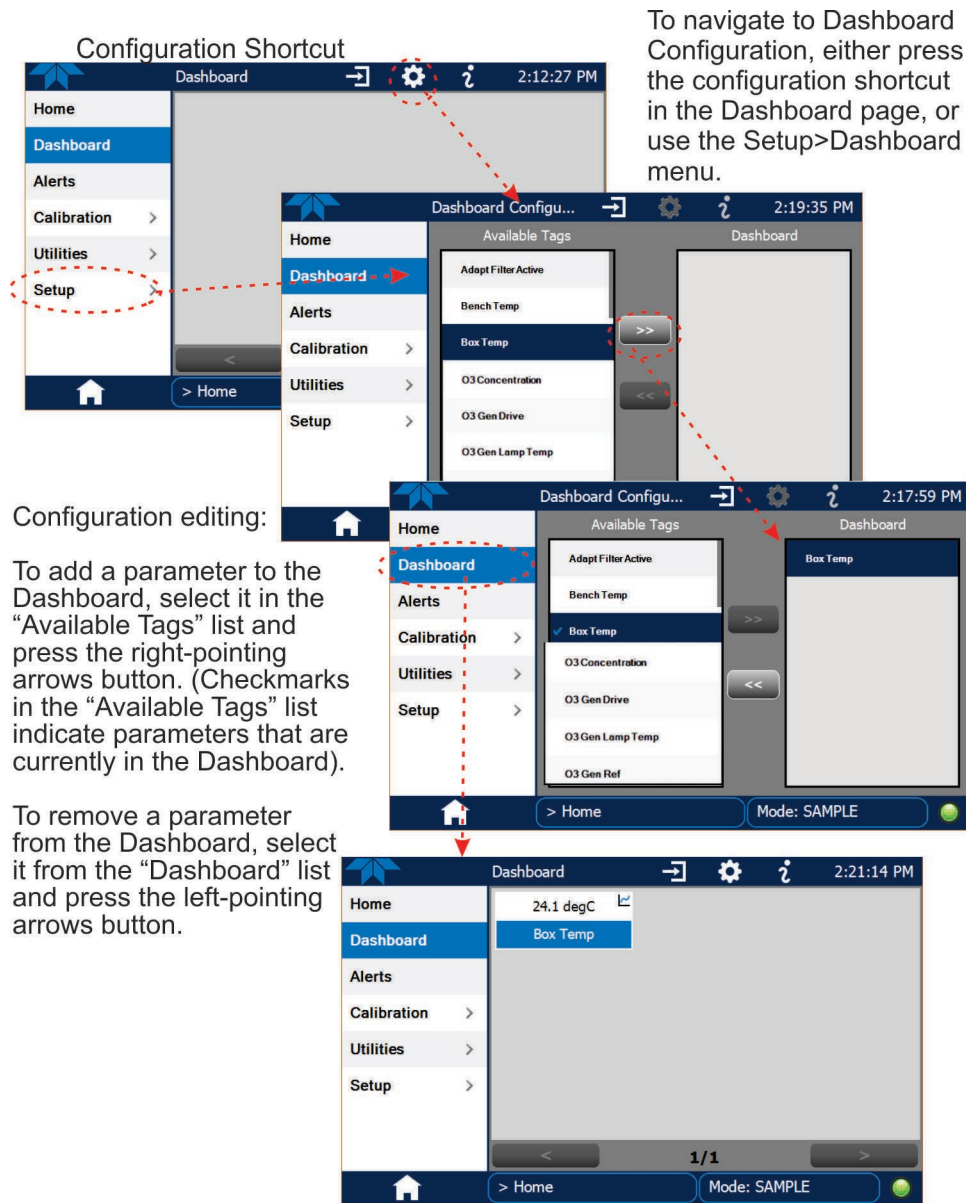

The figure consists of three screenshots illustrating the dashboard configuration process:

- Top Screenshot:** Shows the 'Configuration Shortcut' screen. A red dashed arrow points from the gear icon in the top right to the 'Setup' option in the left-hand menu.
- Middle Screenshot:** Shows the 'Dashboard Configuration' screen. A red dashed arrow points from the 'Setup' option in the menu to the 'Available Tags' list. Another red dashed arrow points from the right-pointing arrow button to the 'Box Temp' tag in the 'Available Tags' list.
- Bottom Screenshot:** Shows the 'Dashboard Configuration' screen with 'Box Temp' selected in the 'Available Tags' list. A red dashed arrow points from the left-pointing arrow button to the 'Dashboard' option in the left-hand menu.

To navigate to Dashboard Configuration, either press the configuration shortcut in the Dashboard page, or use the Setup>Dashboard menu.

Configuration editing:
To add a parameter to the Dashboard, select it in the "Available Tags" list and press the right-pointing arrows button. (Checkmarks in the "Available Tags" list indicate parameters that are currently in the Dashboard).

To remove a parameter from the Dashboard, select it from the "Dashboard" list and press the left-pointing arrows button.

Figure 2-35. Dashboard Display and Configuration

2.5.4 SETUP>AUTO CAL (WITH VALVE OPTION)

Auto Cal, automatic zero/span calibration check is available with installed valve options (see Sections 2.3.2 and 4.3).



2.5.5 SETUP>VARS

Vars are software variables that define operational parameters automatically set by the instrument's firmware, and are user-adjustable through this menu. Access the menu to see the list of variables; select a variable to view its description; touch the Edit button to change its setting(s).

Table 2-11. List of Variables with Descriptions

VARIABLE	DESCRIPTION
<p>NOTE: This list includes several of the more common Vars; selecting any Var in the NumaView™ software interface will display its description in the information field to its right. Depending on configuration, some, all, or more of these variables appear in your instrument's Vars menu.</p>	
Conc Precision (or PRIGAS/SECGAS Precision)	Sets the number of significant digits to the right of the decimal point display of concentration and stability values. ("PRIGAS" = primary gas with two or more other gases; "SECGAS" = secondary gas)
Daylight Savings Enable	Enable or disable Daylight Savings Time (also see Setup>Instrument>Date/Time Settings)
Dilution Factor Option	<p>Sets the instrument to compensate for diluted sample gas, such as in continuous emission monitoring (CEM) where the quality of gas in a smoke stack is being tested and the sampling method used to remove the gas from the stack dilutes the gas. Once the degree of dilution is known, this feature allows the user to add an appropriate scaling factor to the analyzer's gas concentration calculations so that the undiluted values for measurement range and concentration are shown on the instrument's front panel display and reported via the instrument's various outputs.</p> <p>To add the appropriate scaling factor:</p> <ol style="list-style-type: none"> 1. First, check that the analyzer's measurement units are the same as those used for determining the amount of dilution. (The analyzer's measurement units can be changed in the Setup>Vars>User Units menu). 2. Then, set the Dilution Factor Var as a gain to reflect the dilution ratio that was determined. For example, if the amount of dilution is found to be 20 parts diluent to 1 part sample gas (a dilution ratio of 20:1), the gain to be input into the Setup Vars Dilution Factor should be 20 (most common dilution ratio is 100:1). 3. Calibrate the analyzer; ensure that the calibration span gas is either supplied through the same dilution system as the sample gas or has an appropriately lower actual concentration (a concentration that matches the diluted gas concentration prior to having input the Dilution Factor).
[Enable] Software Maintenance Mode	Set instrument to continue sampling, while ignoring calibration, diagnostic, and reset instrument commands.
Instrument ID	Set unique identifier number for the instrument when it is connected with other instruments in multidrop configuration or on the same Ethernet LAN, or when applying MODBUS or Hessen protocols. (Setup>Vars>Instrument ID)
Range Mode	Controls range mode, single (SNGL) or dual (DUAL).
System Hours	Total system runtime hours
User Units	Change the concentration units of measure.

2.5.7 SETUP>DIGITAL OUTPUTS (OPTION)

Specify the function of each digital output (connected through the rear panel Digital I/O connector, Figure 2-5) by mapping the output to a selection of “Signals” present in the instrument. Create custom “Signals” in the Setup>Events menu (Section 2.5.2).

To map Digital Outputs to Signals, select a pin in the Outputs list, then make a selection from the Signals list and press the Map button; if/as needed, change the polarity by pressing the Polarity button. Save any changes by pressing the Apply button, or discard the changes by pressing the Home or the back button (a pop-up provides a warning that the changes will be lost, and will prompt for confirmation to apply changes or not).

For testing, navigate to the Utilities>Diagnostics>Digital Outputs menu to change the state (ON/OFF) of individual digital outputs.

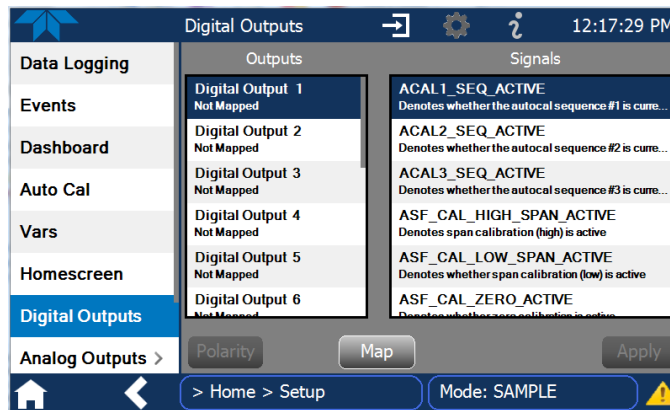

Figure 2-37. Digital Outputs Setup

2.5.8 SETUP>ANALOG OUTPUTS (OPTIONS)

Map the four user-configurable Analog Outputs to any of a wide variety of “Signals” present in the instrument and customize their respective configurations.

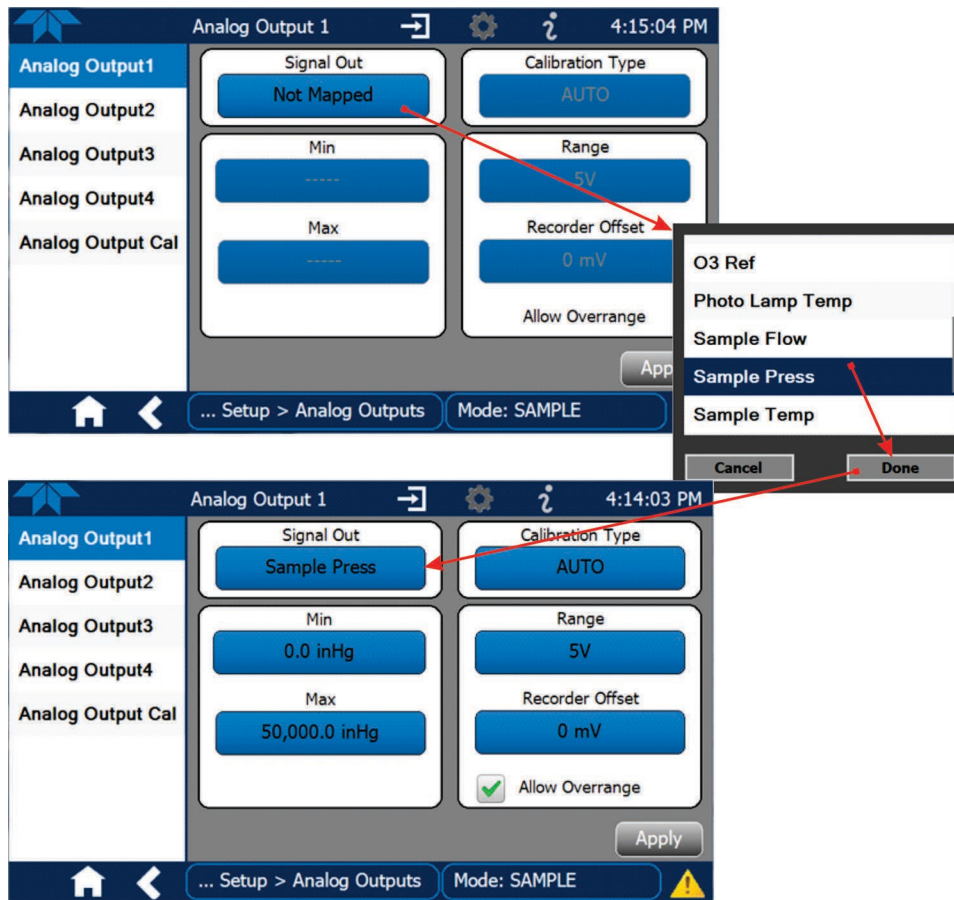

Figure 2-38. Analog Output Configuration Example

Refer to Figure 2-38 for the following:

- Signal Out: select a Signal for the output.
- Min/Max: edit minimum and maximum values associated with the selected Signal.
- Calibration Type:
 - AUTO for group calibration (Figure 2-39) of the analog outputs (cannot be selected when Current is selected for the Range)
 - MANUAL for individual calibration (Figure 2-40) of analog outputs where manual adjustments can be made (the only calibration type allowed when Current is selected for the Range). See Sections 2.5.8.1 and 2.5.8.2 .
- Range: assign a voltage or select Current (refer to Table 2-12).
- Recorder Offset: add a zero offset for recording slightly negative readings from noise around the zero point.
- Allow Overage: check to allow a $\pm 5\%$ over-range; uncheck to disable over-range if the recording device is sensitive to excess voltage or current.

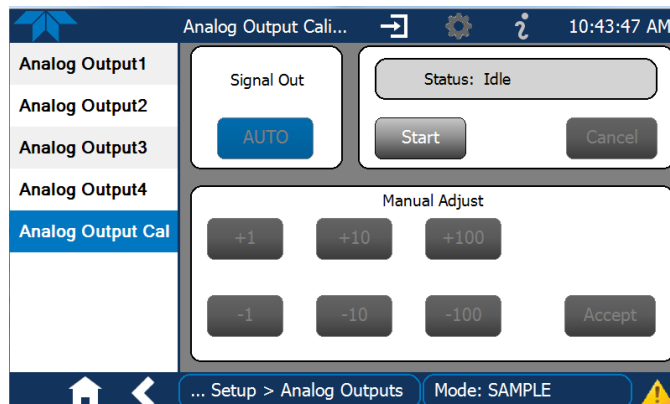

Figure 2-39. Analog Outputs Group Calibration Screen

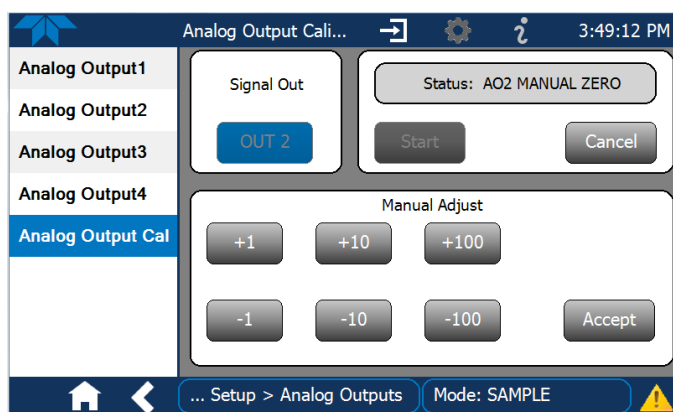

Figure 2-40. Analog Outputs Manual Calibration Screen (AOUT2 Example)

Table 2-12. Analog Output Voltage/Current Range

RANGE ¹	RANGE SPAN	MINIMUM OUTPUT	MAXIMUM OUTPUT
100mV	0-100 mVDC	-5 mVDC	105 mVDC
1V	0-1 VDC	-0.05 VDC	1.05 VDC
5V	0-5 VDC	-0.25 VDC	5.25 VDC
10V	0-10 VDC	-0.5 VDC	10.5 VDC
Current²	0-20 mA	0 mA	20 mA

¹ Each range is usable from -5% to +5% of the rated span.

² While these are the physical limits of the current loop modules, typical applications use 2-20 mA or 4-20 mA for the lower and upper limits.

For manual calibration adjustments, see Section 2.5.8.1 for voltage and Section 2.5.8.2 for current.

2.5.8.1 MANUAL CALIBRATION OF VOLTAGE RANGE ANALOG OUTPUTS

It is possible to manually calibrate the voltages by using a voltmeter connected across the output terminals (Figure 2-41) and changing the output signal level in the Manual Adjust field of the Analog Outputs Calibration screen (Figure 2-40). Refer to Table 2-13 for voltage tolerances.

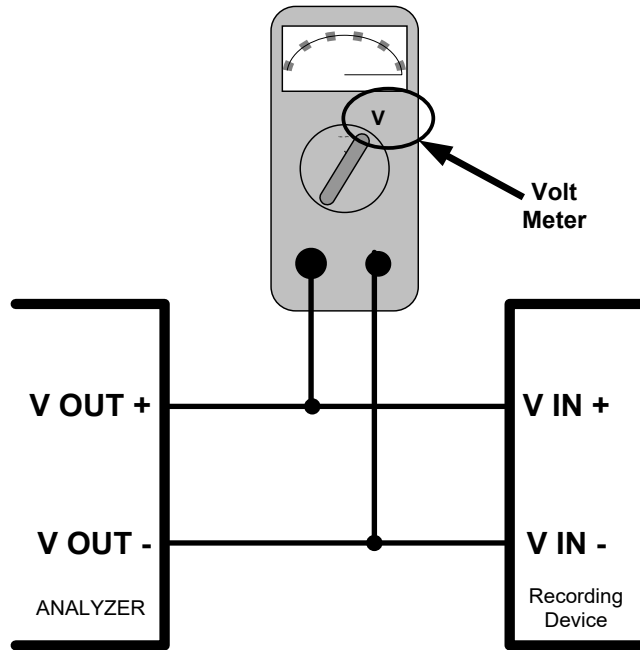

Figure 2-41. Setup for Checking / Calibrating DCV Analog Output Signal Levels

Table 2-13. Voltage Tolerances

FULL SCALE	ZERO TOLERANCE	SPAN VOLTAGE	SPAN TOLERANCE	MINIMUM ADJUSTMENT (1 count)
0.1 VDC	±0.0005V	90 mV	±0.001V	0.02 mV
1 VDC	±0.001V	900 mV	±0.001V	0.24 mV
5 VDC	±0.002V	4500 mV	±0.003V	1.22 mV
10 VDC	±0.004V	4500 mV	±0.006V	2.44 mV

2.5.8.2 MANUAL ADJUSTMENT OF CURRENT RANGE ANALOG OUTPUTS

To manually calibrate the current signals, use an ampmeter (Figure 2-42) connected across the Current output terminals (see Figure 2-4 for pin assignments and diagram of the analog output connector), and changing the output signal level in the Manual Adjust field of the Analog Outputs Current Output Calibration screen. While the software allows this adjustment to be made in 100, 10 or 1 count increments, the adjustments here would need several presses of the +100 button to arrive at a realistic starting point for 4mA.



CAUTION!

Do not exceed 60 V peak voltage between current loop outputs and instrument ground.

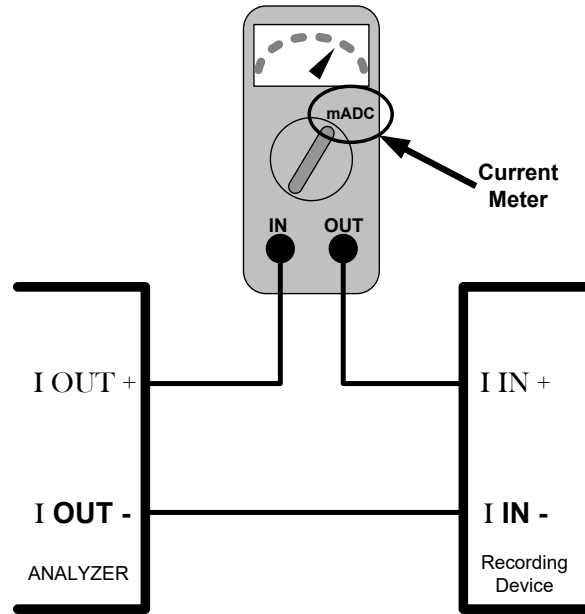

Figure 2-42. Setup for Checking / Calibration Current Output Signal Levels

2.5.9 SETUP>INSTRUMENT

As presented in Table 2-14, view product and system information and network settings, edit network settings, and perform certain maintenance tasks.

Table 2-14. Setup>Instrument Menu

MENU	DESCRIPTION
Product Info	View Model, Part, and Serial Numbers and Package and Driver Versions, and options information.
System Info	View Windows and RAM information.
Network Settings	View the network settings (configurable through the Setup>Comm>Network Settings menu).
Module Info	Provides part and revision numbers of the modules that are installed.
Date/Time Settings	Adjust date, hour, and minutes, select a time zone*, and set the system clock to automatically adjust for Daylight Savings Time or not. (Also see Setup>Vars>Daylight Savings Enable). *Time Zone change requires a special procedure; see Maintenance Section 5.5.
NTP Time Settings	Configure Network Time Protocol settings for clock synchronization.
Language	Select an available language.
Remote Update	When an instrument is connected to a network that is connected to the Internet, follow the instructions on this Remote Update page to check for and activate software/firmware updates. (Also refer to Section 5.3).



2.5.10 SETUP>COMM (COMMUNICATIONS)

This menu is for specifying the various communications configurations.

2.5.10.1 COM2

Configure the instrument's rear panel COM port to operate in modes listed in Table 2-15.

Table 2-15. COM Port Configuration

MODE	DESCRIPTION
Baud Rate	Set the baud rate for the COM1 or COM2 port being configured.
Command Prompt Display	Enable/disable a command prompt to be displayed when in terminal mode.
Data Bits	Set the data bits to 7 or 8 (typically set in conjunction with Parity and Stop bits).
Echo and Line Editing	Enable/disable character echoing and line editing.
Handshaking Mode	Choose SOFTWARE handshaking for data flow control (do NOT use SOFTWARE handshaking mode when using MODBUS RTU for Protocol mode; select only HARDWARE or OFF for MODBUS RTU), or HARDWARE for CTS/RTS style hardwired transmission handshaking. (This style of data transmission handshaking is commonly used with modems or terminal emulation protocols). Or choose to turn OFF handshaking.
Hardware Error Checking	Enable/disable hardware error checking.
Hardware FIFO	Enable/disable the hardware First In – First Out (FIFO) for improving data transfer rate for that COM port.
Modem Connection	Select either a modem connection or a direct cable connection.
Modem Init String	Input an initialization string to enable the modem to communicate.
Parity	Select odd, or even, or no parity (typically set in conjunction with Data Bits and Stop Bits).
Protocol	Select among the communications protocols:MODBUS RTU, or MODBUS ASCII. (Section 3.1.1), Hessen (Section 3.1.2), or REST (Section 3.1.3). If selecting a MODBUS protocol, see Handshaking Mode, this table; MODBUS Registers are presented in Appendix A, this manual. Also see www.modbus.org .
Quiet Mode	Enable/disable Quiet mode, which suppresses any feedback from the analyzer (such as warning messages) to the remote device and is typically used when the port is communicating with a computer program where such intermittent messages might cause communication problems. Such feedback is still available, but a command must be issued to receive them.
Security	Enable/disable the requirement for a password for this serial port to respond. The only command that is active is the request-for-help command (? CR).
Stop bits	Select either 0 or 1 stop bit (typically set in conjunction with Parity and Data bits).

2.5.10.2 TCP PORT2

This menu is configured with the port number for MODBUS (Section 3.1.1).

2.5.10.3 NETWORK SETTINGS

The Setup>Comm>Network Settings menu is for Ethernet configuration. The address settings default to automatic configuration by Dynamic Host Configuration Protocol (DHCP). Most users will want to configure the instrument with a static IP address: click the Static radio button to manually assign a static IP address (consult your network administrator, and see Table 2-16 for information).

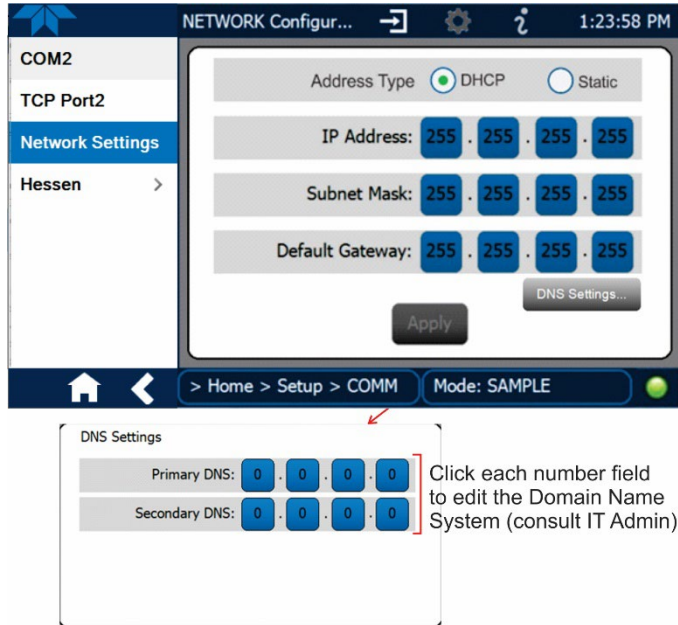

Figure 2-43. Communications Configuration, Network Settings

Table 2-16. LAN/Ethernet Configuration Properties

PROPERTY	DESCRIPTION
IP address	A string of four packets of 1 to 3 numbers each (e.g. 192.168.76.55.) is the internet protocol address of the instrument itself.
Subnet Mask	A string of four packets of 1 to 3 numbers each (e.g. 255.255.252.0) number that masks an IP address, and divides the IP address into network address and host address and identifies the LAN to which the device is connected. All addressable devices and computers on a LAN must have the same subnet mask. Any transmissions sent to devices with different subnets are assumed to be outside of the LAN and are routed through the gateway computer onto the Internet.
Default Gateway	A string of numbers very similar to the Instrument IP address (e.g. 192.168.76.1.) that is the address of the computer used by your LAN and serves as a router to access the Internet or another network.

2.4.1.2 HESSEN

Configure Hessen Settings and Gas List (see Section 3.1.2).

2.6 TRANSFERRING CONFIGURATION TO OTHER INSTRUMENTS

Once an instrument is configured, the same configuration can be copied to other instruments of the same Model. This encompasses essentially anything the user can configure and does not apply to instrument-specific settings such as those that are configured at the factory for calibration.

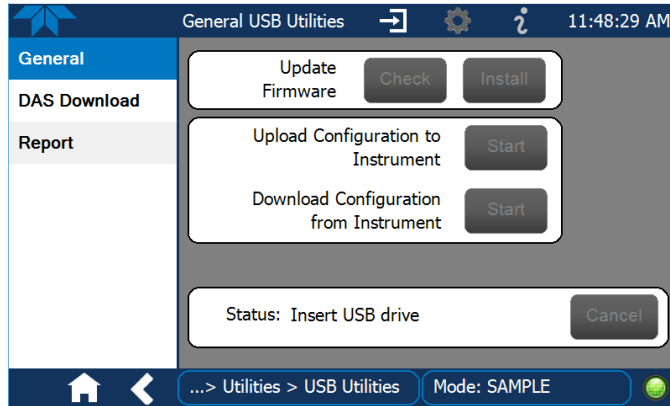

Figure 2-44. Configuration Transfer

1. In the source instrument, go to the Home>Utilities>USB Utilities>General page.
2. Insert a flash drive into either of the two front panel USB ports.
3. When the Status field indicates that the USB drive has been detected, press the “Download Configuration from Instrument” Start button.
4. When the Status field indicates that the download is complete, remove the flash drive.
5. In the target instrument, go to the Home>Utilities>USB Utilities>General page.
6. Insert a flash drive into either of the two front panel USB ports.
7. When the Status field indicates that the USB drive has been detected, press the “Upload Configuration to Instrument” Start button.
8. When the Status field indicates that the upload is complete, remove the flash drive.

3 COMMUNICATIONS AND REMOTE OPERATION

This instrument's rear panel connections include an Ethernet port and a serial communications port. Connection instructions were provided in Section 2.3.1.4. Configuration information was provided in Section 2.5.10.

Data acquisition is set up through the Data Logger (Section 2.5.1).

3.1 SERIAL COMMUNICATION

The rear panel COM port operates on the RS-232 protocol (default configuration is DCE RS-232), or it can be configured for DTE RS-232 operation (more common for PLCs) (Section 2.3.1.4).

Referring to Table 2-15, use the SETUP>COMM menu to view/edit the communications settings for the COM port.

3.1.1 MODBUS

MODBUS communications can be configured through the Setup>Comm>COM2 menu for transmission over Ethernet (Section 3.2) or serial communications.

1. Make the appropriate cable connections between the instrument and a PC.
2. Check the instrument's Modbus Units selection in the Setup>Vars menu and edit if needed.
3. Select the communication protocol for either MODBUS RTU or MODBUS ASCII transmission mode.

Important

When using MODBUS RTU, ensure that the Handshaking Mode is set to either Hardware or OFF. Do NOT set it to Software.

4. Set other parameters as needed (see descriptions in Table 2-15).
5. Press the Accept button to apply the settings.

The Setup>Comm>TCP Port2 is set to 502 for MODBUS by default.

See Appendix A for MODBUS Registers.

3.1.2 HESSEN

Hessen protocol is supported through serial communications. The Hessen protocol is not strictly defined; therefore, while Teledyne API's application is completely compatible with the protocol itself, it may be different from implementations by other companies. Configure the COM2 port for Hessen protocol through the Setup>Comm>COM2 menu: select COM2 Protocol and press Edit to select HESSEN, then press Accept.

Hessen configuration includes settings for alarms, version, response mode, status flags and gas list. Locate the alarms in the Hessen Settings list (Setup>Comm>Hessen>Hessen Settings) and edit as desired.

HESSEN RESPONSE MODE

Set the response mode under Hessen Response Mode, referring to Table 3-1 for descriptions.

Table 3-1. Teledyne API's Hessen Protocol Response Modes

MODE ID	MODE DESCRIPTION
CMD	This is the default setting. Responses from the instrument are encoded as the traditional command format. Style and format of responses depend on exact coding of the initiating command.
BCC	Responses from the instrument are always delimited with <STX> (at the beginning of the response, <ETX> (at the end of the response followed by a 2 digit Block Check Code (checksum), regardless of the command encoding.
TEXT	Responses from the instrument are always delimited with <CR> at the beginning and the end of the string, regardless of the command encoding.

HESSEN VARIATION

For the Hessen Variation setting, there are two versions.

- TYPE 1 is the original implementation.
- TYPE 2 has more flexibility when operating with instruments that can measure more than one type of gas. For more specific information about the difference between the two versions, download the *Manual Addendum for Hessen Protocol* from the Teledyne API's web site: <http://www.teledyne-api.com/manuals/>.

HESSEN STATUS FLAGS

Locate the various status flags in the Hessen Settings list and edit as needed. They are listed by status flag name with their default bit assignments. (Those with unassigned flags are listed as "0x0000").

- The status bits are included in the instrument's responses to inform the host computer of its condition. Each bit can be assigned to one operational and warning message flag.
- It is possible to assign more than one flag to the same Hessen status bit. This allows the grouping of similar flags, such as all temperature warnings, under the same status bit.
- Assigning conflicting flags to the same bit will cause each status bit to be triggered if any of the assigned flags is active.



HESSEN LIST

Table 3-2 describes the Hessen List (Setup>Comm>Hessen menu).

Table 3-2. Hessen List Configuration Summary

ITEM	DEFINITION
Parameter	gas or non-gas parameter : either Add new or Edit existing.
Range	concentration range to be reported (when Reported box is checked)
0	currently active range
1	only when range 1 or low range is active
2	only when range 2 or high range is active
3	not applicable
Id	unique identification for parameter being added or edited
400	typically designated for O3
Reported	check to report when polled by the Hessen network

3.1.3 REST

The REST protocol can be used to collect data, change parameters, extract data logs, poll groups of parameter values, and trigger calibration functions.

The user needs to be familiar with REST principles and underlying network technologies. The REST API service is on port 8180, using HTTP verbs (GET, PUT) and REST Resources in JSON format. Tag names and command strings are case sensitive. The Resources are defined in Table 3-3.

The Teledyne API REST guide is a tutorial in the form of Service Note 22-002, accessible on our website under this product page's Downloads tab.

Table 3-3. REST Resource Descriptions

RESOURCE	DESCRIPTION	OPERATION
Tag	Maps to an instrument tag, allowing direct access to parameter properties/attributes	Read/Write (GET/PUT)
Tag.value	Maps to an instrument tag value separately from its properties for direct/fast access due to dynamic characteristics	Read/Write (GET/PUT)
Tag-list	Queries for instrument's available tags and their properties; query can be filtered for specific tag group	Read only (GET)
Tag-list.value	Retrieves specified group of tag values as a batch; groups include: PRIGAS, LOG, TRIG, AOUTMAP, HIST, TRACK_ALL_UPDATES	Read/Write (GET/PUT)
Datalog-list	Retrieves list of the instrument's available data logs	Read only (GET)
Datalog	Retrieves specified data log, based on a defined page number and number of records per page, or on a defined time range that includes start & end date, hour (24-hr format), minute, and seconds (where blank = default, no seconds)	Read only (GET)

3.2 ETHERNET

When using the Ethernet interface, the analyzer can be connected to any Ethernet network via low-cost network hubs, switches or routers. The interface operates as a standard TCP/IP device on port 3000. This allows a remote computer to connect through the network to the analyzer using NumaView™ Remote, terminal emulators or other programs.

The Ethernet connector has two LEDs that are on the connector itself, indicating its current operating status.

Table 3-4. Ethernet Status Indicators

LED	FUNCTION
green (link)	On when connection to the LAN is valid.
amber (activity)	Flickers during any activity on the LAN.

The analyzer is shipped with DHCP enabled by default. This allows the instrument to be connected to a network or router with a DHCP server; however, it should be configured with a Static IP address as soon as practical. See Section 2.5.10.3 for configuration details.

For MODBUS communications configuration, see Section 3.1.1.

3.3 NUMAVIEW™ REMOTE

For remote operation and data capture through an Ethernet connection, please refer to the NumaView™ Remote Software User Guide, PN 08492, available on our website.

4 CALIBRATION

This Section provides important pre-calibration information, calibration and check procedures, and how to evaluate the quality of each calibration.

4.1 IMPORTANT PRECALIBRATION INFORMATION

Note

A start-up period of 4-5 hours is recommended prior to calibrating the analyzer.

4.1.1 CALIBRATION REQUIREMENTS

Calibration equipment and supplies include, but are not limited to, the following:

- Zero-air source
- Span gas source
- Gas lines - All Gas lines should be PTFE (Teflon) or FEP
- Optionally, a recording device such as a strip-chart recorder and/or data logger. (For electronic documentation, the internal data acquisition system (DAS) can be used by configuring the Data Logger through the Setup>Data Logging menu, Section 2.5.1).
- Traceability Standards

4.1.2 ZERO AIR

Zero air or zero calibration gas is defined as a gas that is similar in chemical composition to the measured medium but without the gas to be measured by the analyzer.

For O₃ measuring devices, zero air should be:

- Devoid of O₃ and Mercury Vapor
- Have a dew point of -20°C

Devices that condition ambient air by drying and removing any pollutants, such as the Teledyne API Model 701 Zero Air Module, are ideal for producing Zero Air.

4.1.3 CALIBRATION (SPAN) GAS

Span Gas is a gas specifically mixed to match the chemical composition of the type of gas being measured at near full scale of the desired measurement range and should be certified traceable to NIST Standard Reference Material (SRM). It is recommended that the span gas used have a concentration equal to 80% of the full measurement range. (For example, if the application is to measure between 0 ppm and 500 ppb, an appropriate span gas would be 400 ppb; between 0 ppb and 1000 ppb, an appropriate Span Gas would be 800 ppb).



If Span Gas is sourced directly from a calibrated, pressurized bottle, use the exact concentration value printed on the bottle.

Because of the instability of O₃, it is impractical, if not impossible, to produce stable concentrations of bottled, pressurized O₃. Therefore, when varying concentrations of O₃ is required for span calibrations they must be generated locally. We recommend using a gas dilution calibrator with a built in O₃ generator, such as a Teledyne API Model T700, as a source for O₃ span gas.

4.1.4 INTERFERENTS

The detection of O₃ is subject to interference from a number of sources including SO₂, NO₂, NO, H₂O and aromatic hydrocarbon meta-xylene and mercury vapor. The Model N400 successfully rejects interference from all of these with the exception of mercury vapor.

If the Model N400 is installed in an environment where the presence of mercury vapor is suspected, steps should be taken to remove the mercury vapor from the sample gas before it enters the analyzer.

For a more detailed discussion of this topic, see Section □.

4.1.5 DILUTION RATIO OPTION SOFTWARE SET UP

If your application involves diluting the sample gas before it enters the analyzer, and the Dilution Ratio Option is enabled:

1. Set the appropriate units of measure (Setup>Vars>User Units).
2. Select the reporting range mode (Setup>Vars>Range Mode [Single or Dual]).
3. Set the reporting range (Setup>Analog Outputs>Analog Output[#]>O₃ Concentration, Min Max). Ensure that the upper span limit entered for the reporting range (in the Max field) is the maximum expected concentration of the undiluted gas.
4. Set the dilution factor as a gain, e.g., a value of 20 means 20 parts diluent and 1 part sample gas (Setup>Vars>Dilution Factor).
5. Calibrate the analyzer; ensure that the calibration span gas is either supplied through the same dilution system as the sample gas or has an appropriately lower actual concentration.

EXAMPLE: If the reporting range limit is set for 100 ppm and the dilution ratio of the sample gas is 20 gain, either:

- a span gas with the concentration of 100 ppm can be used if the span gas passes through the same dilution steps as the sample gas, or;
- a 5 ppm span gas must be used if the span gas **IS NOT** routed through the dilution system.

4.1.6 DATA RECORDING DEVICES

A strip chart recorder, data acquisition system or digital data acquisition system should be used to record data from the serial or analog outputs.

- If analog readings are used, the response of the recording system should be checked against a NIST traceable voltage source or meter.



- Data recording devices should be capable of bi-polar operation so that negative readings can be recorded.
- For electronic data recording, make use of the internal data acquisition system (DAS) by setting up the Data Logger.

4.2 CALIBRATION PROCEDURES

Check that the pneumatic connections for the specific instrument configuration are as instructed in Section 2.3.2.

Verify/change (if needed) the settings as follows:

- User Units (unit of measure): PPB (Setup>Vars>User Conc Units)
- Min and Max Concentration Range (Max should be highest concentration expected to measure) (Setup>Analog Outputs>Analog Output[#], Signal Out, [Gas] Concentration)
- Range Mode: SNGL (Setup>Vars>Range Mode)

Note

Tips for Setting the Expected Span Gas Concentration:

- **When setting expected concentration values, consider impurities in your span gas source.**
- **The expected span gas concentration should be 80% of the reporting range of the instrument.**

To calibrate or to perform a calibration check for basic configuration instruments, see Section 4.2.1.

To calibrate or to perform a calibration check for instruments with valve options, see Section 4.2.2.

To perform automatic calibration check for instruments with the internal span gas generator, see Section 4.3.

4.2.1 CALIBRATION AND CHECK PROCEDURES FOR BASIC CONFIGURATION

Although this Section uses the Calibration menu for both check and actual calibration, a check does not require the Calibration menu. Instead, while in Home page, simply flow the zero air or the applicable span gas through the Sample port, and check the reading after the Stability falls below 1.0 PPB (either in the gas graph or in the Dashboard).

Otherwise, follow the steps presented in Sections 4.2.1.1 and 4.2.1.2.

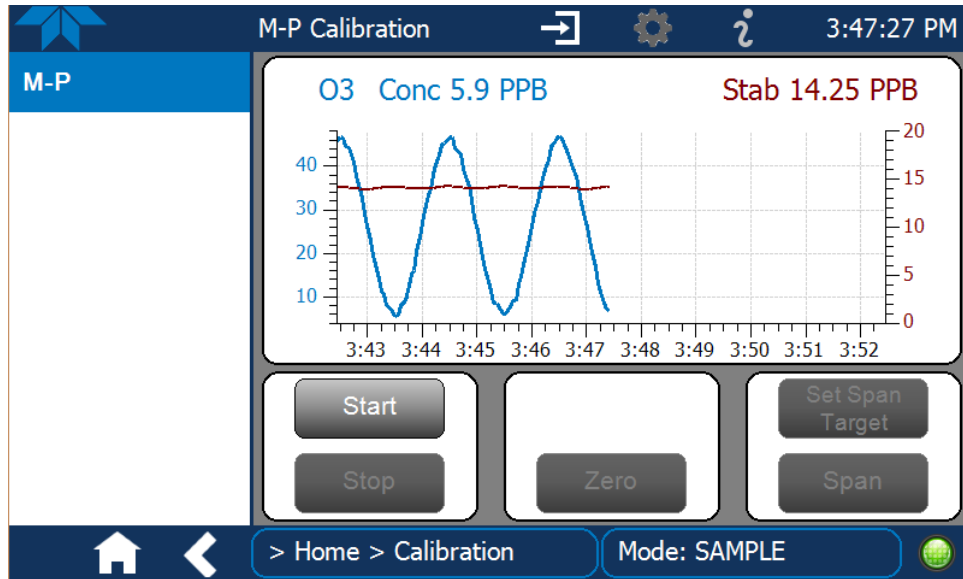

Figure 4-1. Multi-Point Calibration Page

4.2.1.1 ZERO CALIBRATION CHECK AND ACTUAL CALIBRATION

1. Go to the Calibration>M-P menu.
2. Input Zero air through the Sample port and press the Start button.
3. Either check or calibrate as follows:

CHECK ONLY:

- a. Wait to reach stability.
- b. Press Stop and check the reading.

ACTUAL CALIBRATION:

- a. Wait to reach stability, then press the Zero button.
- b. Press Stop and check the reading.

4.2.1.2 SPAN CALIBRATION CHECK AND ACTUAL CALIBRATION

1. While still in the Calibration>M-P menu, input Span gas through the Sample port and press the Start button.
2. Either check or calibrate as follows (note that reaching stability can sometimes take an hour or more):

CHECK ONLY:

- a. Wait to reach stability, then press Stop.
- b. Record the reading.

ACTUAL CALIBRATION:

- a. Press the Set Span Target button and enter the span gas concentration.
 - b. Verify the concentration reading is the same as the span gas concentration being supplied.
 - c. If incorrect, wait to reach stability, then press the Span button.
 - d. In the Cal Result window, press OK.
3. Press the Stop button and return to Home screen.
 4. In the Dashboard, check and record the Slope(s) and the Offset(s). (See Section 4.4 regarding these values).

4.2.2 CALIBRATION AND CHECK PROCEDURES WITH VALVE OPTIONS INSTALLED



Figure 4-2. Zero and Span Calibration Screens

Follow the instructions in Section 4.2.1, except instead of the M-P menu, go to the Calibration>Zero menu for Zero cal and to the Calibration>Span menu for O3 Span cal.



4.2.2.1 AUTOMATIC CAL CHECKS (AUTO CAL) WITH ZERO/SPAN VALVE

Digital inputs are available for calibration checks when the Digital I/O Board option is installed. Instructions for setup and use of this option are outlined in Section 2.3.1.3.

4.3 AUTOMATIC ZERO/SPAN CALIBRATION CHECK (AUTO CAL)

The Auto Cal feature allows unattended periodic calibration checks with the ZERO/SPAN valve option by executing up to three separate preprogrammed sequences (labeled # 1, 2 and 3). Each calibration check can operate in either Zero mode or Span mode. The Auto Cal feature requires that the instrument remain in Calibration mode after the values reset to ambient, in order to continue flagging the data until purging is complete. This is accomplished with the Auto Cal Purge VAR.

To continue calibration until the system is purged, navigate to Setup>Vars>AutoCal Purge and use the Edit button to select the number of minutes for the purge duration.

To program the calibration checks for future execution (Figure 4-3), in the numbered sequence row (#1, #2, #3), click the Zero box or the Span box to select the valve to be switched open, then input the Start, Interval, and Duration parameters (refer to Table 4-1) in the active field for that sequence (identified by the matching number in its upper left corner). Checking the Enabled box for that sequence allows the program to execute at the time, frequency and duration programmed, once the Apply button is clicked.

However, if a calibration or calibration check is initiated outside of Auto Cal, the user-initiated operation will override the Auto Cal sequence.

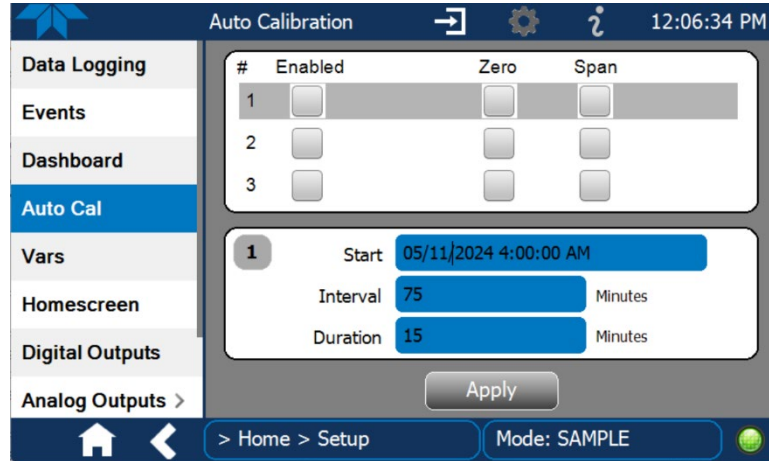

Figure 4-3. Auto Cal Page

Table 4-1. Auto Cal Programming Sequence Execution

ATTRIBUTE	ACTION
Start	When the Enabled box is “on” <input checked="" type="checkbox"/> , the Sequence (identified by its number) begins on the date and time shown in the configurable Start field. (Click the field for the pop-up window and toggle between the Time (Hour/Minutes) and the Date (Year/Month/Day) attributes to edit as needed).
Interval	Number of minutes to skip between each Sequence execution. (Click the field to input the number of minutes in the pop-up window).
Duration	Number of minutes that each Sequence execution is to run. (Click the field to input the number of minutes in the pop-up window).

IMPORTANT

IMPACT ON READINGS OR DATA

- The programmed **STARTING_TIME** must be a minimum of 5 minutes later than the real time clock for setting real time clock (Setup>Instrument, Section 2.5.9).
- Avoid setting two or more sequences at the same time of the day.
- Any user-initiated calibration or calibration check that overlaps or coincides with a preprogrammed Auto Cal check will override the Auto Cal check.
- It is recommended that calibrations be performed using external sources of Zero Air and Span Gas whose accuracy is traceable to EPA standards.



4.4 CALIBRATION QUALITY

After completing any of the calibration procedures described above, it is important to evaluate the analyzer's calibration **SLOPE** and **OFFSET** parameters. These values describe the linear response curve of the analyzer. The values for these terms, both individually and relative to each other, indicate the quality of the calibration.

To perform this quality evaluation, check these parameters in the Dashboard (Setup>Dashboard to configure if needed) and frequently compare them to those values on the *Final Test and Validation Data Sheet* that was shipped with your instrument, which should not be significantly different. If they are, refer to the Troubleshooting content in Section 5.

4.5 CALIBRATION OF THE ELECTRONIC SUBSYSTEMS

There are several electronic characteristics of the N400 analyzer's photometer that may occasionally need checking or calibration. These calibrations include Dark Calibration, Pressure Cal and Flow Cal (and O₃ Gen Cal when the O₃ Generator option is installed), all located under the Utilities>Diagnostics menu.

4.5.1 PRESSURE CALIBRATION

A sensor at the exit of the sample chamber continuously measures the pressure of the sample gas. The data for Sample Pressure are used to compensate the final gas concentration calculation for changes in atmospheric pressure and are stored in the CPU's memory.

IMPORTANT

Impact on Readings or Data

This calibration must be performed when the pressure of the sample gas is equal to ambient atmospheric pressure. Before performing the following pressure calibration procedure, power off the sample gas pump through the software only, and then disconnect the sample gas-line vent from the rear panel sample gas inlet.

ATTENTION

COULD DAMAGE INSTRUMENT AND VOID WARRANTY
Do NOT disconnect or reconnect the pump's power cable from its control PCA while the instrument is running. This will damage the PCA and render the instrument useless until the PCA or module is replaced.

1. Power down the pump via the Pump Control Mode Var.
2. Activate this procedure in the Utilities>Diagnostics>Pressure Cal menu.
3. When finished, reconnect the sample gas line vent to the rear panel sample gas inlet.
4. To restore power to the pump, select "Constant" for this HD pump.



4.5.2 FLOW CALIBRATION

The flow calibration allows the user to adjust the values of the sample flow rates as they appear in the Dashboard to match the actual flow rate measured at the sample inlet. This does not change the hardware measurement of the flow sensors, only the software-calculated values.

To carry out this adjustment, connect an external, sufficiently accurate flow meter to the sample inlet per Section 5.6.5. Once the flow meter is attached and is measuring actual gas flow, use the Utilities>Diagnostics>Flow Cal menu to input the flow meter reading and calibrate.

4.5.3 O₃ GEN CALIBRATION (WITH IZS OPTION)

This function calibrates the O₃ Generator that comes with the IZS option, by setting the IZS O₃ Generator output to a series of levels between zero and full scale and matching each level to a drive voltage from the generator lamp. This calibration is typically performed when the O₃ Generator lamp requires adjustment or replacement.

5. MAINTENANCE AND SERVICE

Although this instrument requires little service, a few simple procedures should be performed regularly to ensure that it continues to operate accurately and reliably over its lifetime. In general, the exterior can be wiped down with a lightly damp cloth.

5.1 MAINTENANCE SCHEDULE

Table 5-1 shows a typical maintenance schedule for the instrument. The actual frequency of performing these procedures can vary depending on the operating environment. Additionally, in some cases, there are local regulations or standards that also need to be considered.

In certain environments (e.g., dusty, very high ambient pollutant levels) some maintenance procedures may need to be performed more often than shown.



WARNING – Electrical Shock Hazard

Disconnect power before performing any of the following operations that require entry into the interior of the analyzer.



CAUTION – Qualified Personnel

These maintenance procedures must be performed by qualified technicians only.

ATTENTION

COULD DAMAGE INSTRUMENT AND VOID WARRANTY

Always power off the instrument before disconnecting or reconnecting internal electrical assemblies. Failure to do so can cause damage to instrument.

When cleaning (or any time), avoid spraying anything directly onto any part of the analyzer.



Important

IMPACT ON READINGS OR DATA

A Span and Zero Calibration Check (see CAL CHECK REQ'D Column of Table 5-1) must be performed following certain of the maintenance procedure listed below. To perform a CHECK of the instrument's Zero or Span Calibration, refer to Sections 4.2.1.1 and 4.2.1.2, respectively.

Alternatively, use the Auto Cal feature described in Section 4.3.

Table 5-1. N400 Maintenance Schedule

ITEM	ACTION	FREQ	CAL CHECK REQ'D. ¹	MANUAL SECTION	DATE PERFORMED													
Particulate Filter 47mm option	Replace membrane element	Weekly or as needed	Yes	5.6.1														
Long-Life Filter option	Replace	Annually or as needed for highly polluted sample air	No	5.6.2														
Verify Dashboard Functions	Record and analyze	Weekly or after any Maintenance or Repair	No	5.7.2														
Pump Diaphragm	Replace	As Needed	Yes	(kit)														
O ₃ Reference Scrubber	Replace	Every 2-5 years, as needed	Yes	5.8.2.1														
IZS Zero Air Scrubber	Replace	Annually	No	5.8.4														
Absorption Tube	Inspect --- Clean	Annually --- As Needed	Yes	5.6.6														
Flow Check	Perform Flow Check	Every 6 Months	No	5.6.5														
Leak Check	Perform Leak Check	Annually or after any Maintenance or Repair	Yes	5.6.4														
Pneumatic lines	Examine and clean	As needed	Yes if cleaned	--														

This page intentionally left blank.



5.2 PREDICTIVE DIAGNOSTICS

These Functions can be used to predict failures by looking at how their values change over time. Initially it may be useful to compare the state of these functions to the values recorded on the printed record of the Final Test and Validation Data Sheet for your instrument. Table 5-2 can be used as a basis for taking action as these values change with time. The Data Logger (internal data acquisition system or DAS) is a convenient way to record and track these changes (Section 2.5.1). Use NumaView™ Remote to download and review this data from a remote location.

The following table, checked weekly, can be used as a basis for taking action as these values change with time:

Table 5-2. Predictive Uses for Dashboard Functions

FUNCTION	CONDITION	BEHAVIOR	INTERPRETATION
STABILITY	Zero Cal	Increasing	<ul style="list-style-type: none"> • Pneumatic leaks – instrument & sample system • Malfunctioning UV lamp (Bench)
O3 REF	Sample	Decreasing	<ul style="list-style-type: none"> • Lamp Aging • Mercury contamination
O3 DRIVE	CalS	Increasing	<ul style="list-style-type: none"> • Aging IZS UV lamp (only if reference detector option is installed)
SAMPLE PRESSURE	Sample	Increasing > 1"	<ul style="list-style-type: none"> • Pneumatic Leak between sample inlet and optical bench
		Decreasing > 1"	<ul style="list-style-type: none"> • Dirty particulate filter • Pneumatic obstruction between sample inlet and optical bench • Obstruction in sampling manifold
SAMPLE FLOW	Sample	Decreasing	<ul style="list-style-type: none"> • Pump diaphragm deteriorating • Sample flow orifice plugged/obstructed • Pneumatic obstruction between sample inlet and optical bench • Obstruction in sampling manifold
O3 OFFSET	Zero Cal	Increasing	<ul style="list-style-type: none"> • Obstructed/leaking Meas/Ref Valve • Pneumatic leaks – instrument & sample system
		Decreasing	<ul style="list-style-type: none"> • Contaminated zero calibration gas • Obstructed Meas/Ref Valve • Pneumatic leaks – instrument & sample system
O3 SLOPE	Span Cal	Increasing	<ul style="list-style-type: none"> • Pneumatics becoming contaminated/dirty • Dirty particulate filter • Pneumatic leaks – instrument & sample system
		Decreasing	<ul style="list-style-type: none"> • Contaminated calibration gas

5.3 OPERATIONAL HEALTH CHECKS

Navigate to the Utilities>USB Utilities>Report menu (Figure 5-1) to download a report on the basic operations of the instrument. To download the report for your own viewing on a computer or to send to others, insert a flash drive into a front panel USB port and press the Download button, which is enabled when the instrument detects the flash drive.

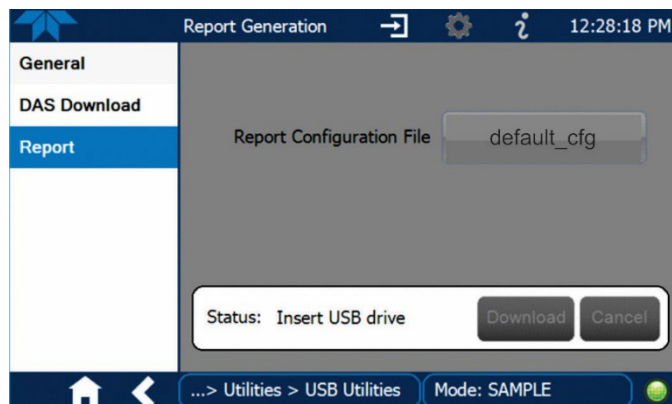

Figure 5-1. Report Generation Page

The report can also be set to generate periodically and sent to a Web services “cloud” where it is available for viewing by Teledyne API technical support personnel. Set this function with two Vars:

Setup>Vars>Upload Report to Cloud: set to True.

Setup>Vars>Report Upload>Interval: edit the number of hours between report uploads.

5.4 SOFTWARE/FIRMWARE UPDATES

There are two ways to check for and acquire updates: either remotely or manually.

5.4.1 REMOTE UPDATES

The instrument must be connected to a network that is connected to the Internet. In the Setup>Instrument menu, select the Remote Update menu and press the Check for Updates button. If an update is available, it can be downloaded through this page.

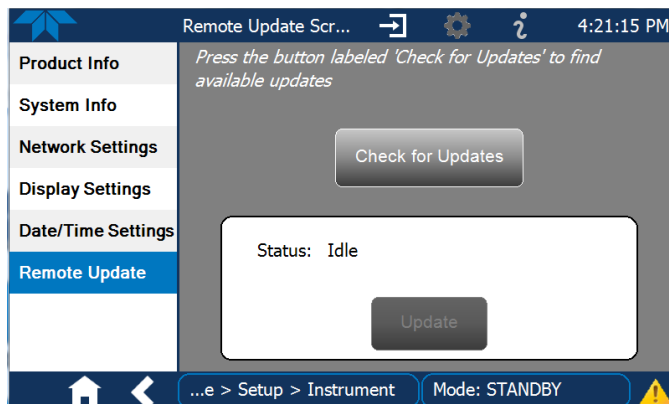

Figure 5-2. Remote Update Page

5.4.2 MANUAL RELOAD/UPDATE PROCEDURES

To reload or update firmware, first contact Technical Support to obtain the applicable file(s): api-techsupport@teledyne.com /+1 800-324-5190.

1. Follow Technical Support's instructions for copying the firmware files to a flash drive.
2. Go to the Utilities>USB Utilities>General menu.

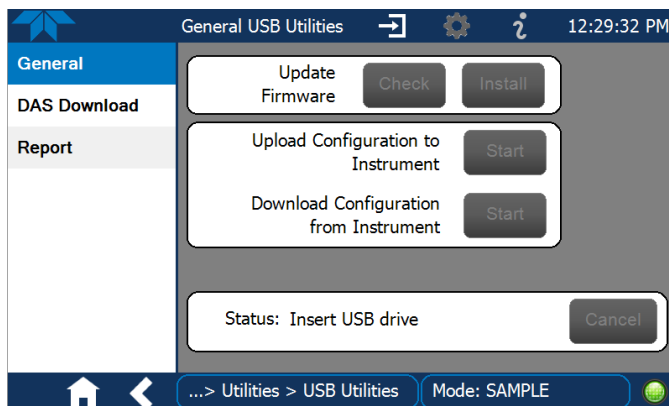

Figure 5-3. Manual Update Page (and other utilities)

3. Insert a flash drive into a front panel USB port and wait for the Status field to indicate that the drive has been detected.
4. In the Update Firmware field, press the Check button for the instrument to determine whether the firmware on the flash drive is more recent than what is currently installed. Once it's been determined that the firmware is new, the Install button will be enabled; if the firmware version on the flash drive is the same as or older than the current firmware of the instrument, the Install button will not be enabled.
5. Press the Install button and note the messages in the Status field at the bottom of the page. Use the Cancel button if necessary.
6. When complete, as indicated in the Status field, press the Done button, which replaces the Cancel button, and remove the flash drive.
7. Power off and restart the instrument to complete the new firmware installation.

5.5 TIME ZONE CHANGES

There is an option to change between 12-hour and 24-hour format in the Setup>Vars menu (System Time Format). Effectively changing the Time Zone requires a specific procedure as follows:

1. In Setup>Instrument>Date/Time Settings select the applicable Time Zone.
2. Allow adequate time for the selected Time Zone to be properly accepted.
3. Verify: return to Home page then back to the Date/Time Settings page, and check that the selected Time Zone is now highlighted.
4. **Without making any other changes, power OFF the instrument and power ON again.**
5. Once restarted, return to the Date/Time Settings page where the newly selected Time Zone should be highlighted. (If not, it means that not enough time had passed for the instrument to accept the change before the power was cycled OFF).
6. After the Time Zone is implemented first (Steps 1 through 5), then other changes to the date and/or time can be made, and recycling the power is not necessary.

- ① **Time zone** change must be set **first**.
- ② **Wait**. Allow sufficient time to accept new Time Zone.
- ③ **Verify**. Return to Home page, then return to Date/Time Settings page.
- ④ After correct Time Zone is displayed, **power recycle** the instrument.
- ⑤ Only after Time Zone is selected and instrument rebooted, can other changes to date and/or time be made effectively.

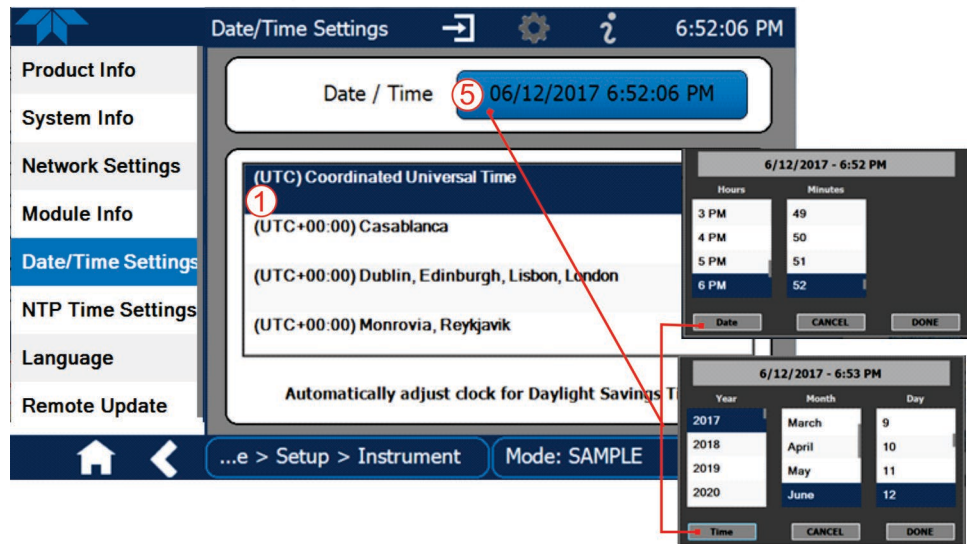

Changes to date and/or time do **not** require a reboot.

Figure 5-4. Time Zone Change Requirements

5.6 MAINTENANCE PROCEDURES

The following procedures are to be performed periodically as part of the standard maintenance of the N400.

5.6.1 REPLACING THE 47 MM SAMPLE PARTICULATE FILTER OPTION

If the instrument is equipped with the 47mm filter option, inspect it often for signs of plugging or contamination. It should be replaced according to the service interval schedule even without obvious signs of dirt, as filters with 1 and 5 μm pore size can clog up while retaining a clean look.

Important

IMPACT ON READINGS OR DATA

Use gloves or PTFE coated tweezers or similar handling to avoid contamination of the sample filter assembly. Do not touch any part of the housing, filter element, PTFE retaining ring, glass cover and the o-ring with bare hands, as contamination can negatively impact accuracy of readings.

To change the filter element:

1. Turn OFF the analyzer to prevent drawing debris into the instrument.
2. Open the N400's hinged rear panel and unscrew the knurled retaining ring on the filter assembly.

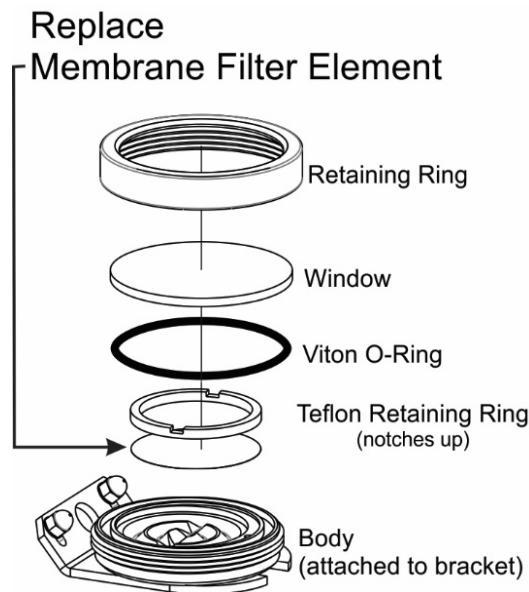

Figure 5-5. Replacing the Particulate Filter's Membrane Element

3. Carefully remove the Retaining Ring, the glass Window, the notched Retaining Ring, and the used Membrane Filter Element (the Viton O-Ring may come up with the Window or it may remain nested in the Body).
4. Replace the filter, being careful that the element is fully seated and centered in the bottom of the holder.



5. Re-install the PTFE o-ring (with the notches up), the glass cover, then screw on the retaining ring and hand tighten. Inspect the seal between the edge of filter and the o-ring to assure a proper seal.
6. Close panel and restart the Analyzer.

5.6.2 REPLACING THE LONG-LIFE DFU FILTER OPTION

For analyzers equipped with the long-life DFU filter, if and when it needs to be replaced, the DFU is easily accessible for removal and replacement.

To replace:

1. Power OFF the analyzer to prevent drawing debris into the instrument.
2. Access the old filter by lowering the hinged portion of the rear panel.
3. Noting the orientation of the filter (imprinted arrow indicates direction of flow), remove filter's tie-down and disconnect its fittings. Dispose of according to code.
4. Install the replacement filter in the same orientation.
5. Secure with tie-down.
6. Close and secure hinged rear panel, power up instrument, and allow time for conditioning.
7. Conduct zero and span calibrations and allow time to stabilize.

5.6.3 REPLACING THE IZS OPTION ZERO AIR SCRUBBER

1. Power OFF the analyzer.
2. Remove the cover from the analyzer.
3. Disconnect the white nylon 1/4"-1/8" fitting from the Zero Air Scrubber (See Figure 5-6).
4. Remove the old scrubber by disconnecting the 9/16" fitting at the top of the O₃ generator tower, then removing the scrubber.
5. Install the new scrubber by reversing these instructions.



N400

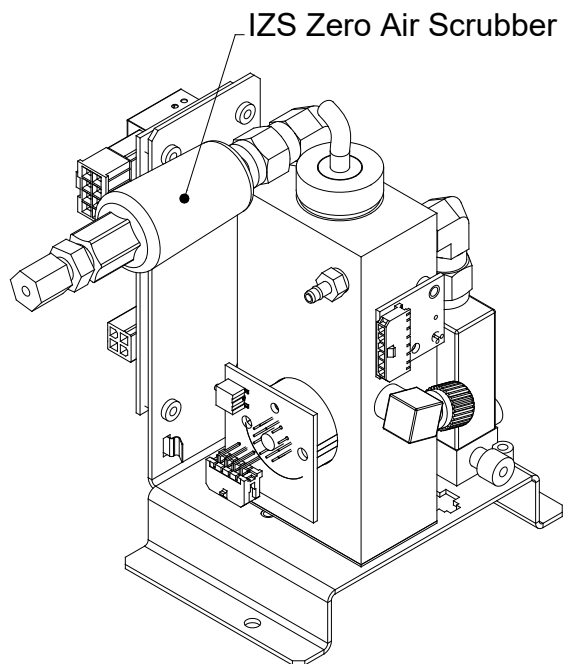

Figure 5-6. Replacing the IZS Zero Air Scrubber

5.6.4 PERFORMING LEAK CHECKS

Leaks are the most common cause of analyzer malfunction; Section 5.6.4.1 presents a simple leak check procedure. Section 5.6.4.2 details a more thorough procedure.

5.6.4.1 VACUUM LEAK CHECK AND PUMP CHECK

This method is easy and fast. It detects but does not locate most leaks. It also verifies that the sample pump is in good condition.

1. Turn the analyzer ON and allow enough time for flows to stabilize.
2. Cap the sample inlet port.
3. After a few minutes, when the pressure has stabilized, note the SAMPLE PRESSURE reading in the Dashboard.
 - If the reading is < 10 in-Hg, the pump is in good condition and there are no large leaks.
4. Check the sample gas flow.
 - If the flow is < 10 cm³/min and stable, there are no large leaks in the instrument's pneumatics.

5.6.4.2 PRESSURE LEAK CHECK

If you can't locate the leak by the above procedure, obtain a leak checker that contains a small pump, shut-off valve, and pressure gauge. Alternatively, use a tank of pressurized gas, with the two-stage regulator adjusted to less than 15 psi with a shutoff valve and pressure gauge.



CAUTION

Do not use bubble solution with vacuum applied to the analyzer, as the solution may contaminate the instrument. Do not exceed 15 PSIG pressure.

1. Turn OFF power to the instrument.
2. Install a leak checker or tank of gas as described above on the sample inlet at the rear panel.
3. Install a cap on the rear panel's EXHAUST fitting.
4. Open the rear panel hinged cover to access the sample pump. Disconnect the two fittings on the sample pump and install a union fitting in place of the pump. The analyzer cannot be leak checked with the pump in line due to internal leakage that normally occurs in the pump.
5. Pressurize the instrument with the leak checker, allowing enough time to fully pressurize the instrument through the critical flow orifice. Check each fitting with soap bubble solution, looking for bubbles. Once the fittings have been wetted with soap solution, do not re-apply vacuum, as it will suck soap solution into the instrument and contaminate it. Do not exceed 15 psi pressure.

6. If the instrument has one of the zero and span valve options, the normally closed ports on each valve should also be separately checked. Connect the leak checker to the normally closed ports and check with soap bubble solution.
7. If the analyzer is equipped with an IZS option, connect the leak checker to the dry air inlet and check with soap bubble solution.
8. Once the leak has been located and repaired, the leak-down rate should be < 1 in-Hg (0.4 psi) in 5 minutes after the pressure is shut off.

5.6.5 PERFORMING A SAMPLE FLOW CHECK

CAUTION



Always use a separate calibrated flow meter capable of measuring flows in the 0 – 1000 cc/min range to measure the gas flow rate though the analyzer.

DO NOT use the built in flow measurement viewable from the Front Panel of the instrument. This measurement is only for detecting major flow interruptions such as clogged or plugged gas lines.

See rear panel for SAMPLE port location.

1. Power off the analyzer.
2. Attach the flow meter to the sample inlet port on the rear panel. Ensure that the inlet to the flow meter is at atmospheric pressure.
3. Sample flow should be $800 \text{ cm}^3/\text{min} \pm 10\%$.
 - Low flows indicate blockage somewhere in the pneumatic pathway, typically a plugged sintered filter or critical flow orifice in one of the analyzer's flow control assemblies.
 - High flows indicate leaks downstream of the Flow Control Assembly.
4. Once an accurate measurement has been recorded by the method described above, adjust the analyzer's internal flow sensors (See Section 4.5.2).

5.6.6 MAINTAINING THE PHOTOMETER ABSORPTION TUBE

NOTE

This procedure should never be needed as long as the photometer is supplied with clean, dry, particulate-free zero air only. However, this procedure is included for the rare event that cleaning or replacing the absorption tube is required.

1. Power off the unit.
2. Remove the cover from analyzer.
3. Locate the optical bench.
4. Remove the top cover of the optical bench.
5. Unclip the sample thermistor from the tube.
6. Loosen the two screws on the round tube retainers at either end of the tube.
7. Using both hands, carefully rotate the tube to free it.

8. Slide the tube towards the lamp housing.
 - Slide the front of the tube past the detector block and out of the instrument.



CAUTION – General Safety Hazard

Do not cause the tube to bind against the metal housings: the tube may break and cause serious injury.

9. Clean the tube only with de-ionized water.
10. Air dry the tube.
11. Check the cleanliness by looking down the bore of the tube.
 - It should be free from dirt and lint.
12. Inspect the o-rings that seal the ends of the optical tube (these o-rings may stay seated in the manifolds when the tube is removed.)
 - If there is any noticeable damage to these o-rings, they should be replaced.
13. Re-assemble the tube into the lamp housing and return the top cover of the optical bench.
14. Prior to tightening the retainer screws, gently push the tube all the way toward the front of the optical bench when it is reassembled; this will ensure that the tube is assembled with the forward end against the stop inside the detector manifold.
15. Return the cover to the analyzer and power up the analyzer.
16. Perform an **AUTO LEAK CHECK** on the instrument.

5.6.7 REPLACING THE OPTICAL BENCH UV LAMP

This procedure details the steps for replacement of the UV source lamp in the optical bench assembly. This procedure should be done whenever the Photo Detector signal value can no longer be adjusted to or above 1000 mV.



CAUTION – UV Radiation Risk

Power off the instrument before proceeding with lamp replacement. When the instrument is powered back on during this procedure, do not look directly at the light of the UV lamp. Use safety glasses rated for UV protection while performing the adjustments.

1. Power off the analyzer.
2. Remove the cover from the analyzer.
3. Locate the Optical Bench Assembly Locate the UV lamp at the front of the optical bench assembly (see Figure 2-3).
4. Unplug the lamp cable from the power supply connector on the side of the optical bench.
5. Slightly loosen (do not remove) the UV lamp setscrew and pull the lamp from its housing.

6. Install a new lamp in the housing, pushing it all the way in.
 - Leave the UV lamp setscrew loose for now.
7. Turn the analyzer back on and allow it to warm up for at least 15 minutes.
8. Navigate to Utilities>Diagnostics>Analog Inputs>Photo Detector.
9. While ensuring that the new lamp is pushed all the way into the housing, slightly rotate the lamp up to ¼ turn in either direction until the maximum Photo Detector signal value is observed.
10. At the point where the Photo Detector signal reaches maximum observed value, tighten the lamp setscrew at that position.
11. Replace the cover on the analyzer.

5.6.8 ADJUSTING OR REPLACING THE IZS OZONE GENERATOR OPTION'S UV LAMP

This procedure details the steps for replacing and calibrating the UV lamp of the O₃ Generator that is included in the Internal Zero Span (IZS) option. If adjusting an existing lamp, skip to Step 7.



CAUTION – Mercury Exposure Risk

The UV lamp contains mercury (Hg), which is considered hazardous waste. The lamp should be disposed of in accordance with local regulations regarding waste containing mercury.

1. Power off the analyzer.
2. Remove the cover from the analyzer.
3. Locate the O₃ generator (see Figure 2-3).

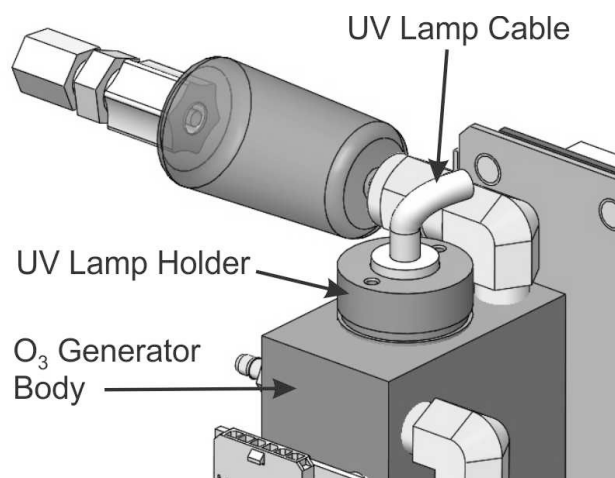

Figure 5-7. O₃ Generator UV Lamp

4. Unscrew the UV lamp holder and gently pull out the old lamp.
5. Inspect the o-ring beneath the lamp holder and replace if damaged.

6. Install the new lamp in O₃ generator housing, and partially tighten the UV lamp holder.
 - The lamp should be free enough to be rotated in the assembly by grasping the lamp cable.
7. Power on the analyzer and allow it to stabilize for at least 20 minutes.
8. Navigate to Dashboard>O₃ Gen Ref (configure the Dashboard if needed).
9. While watching the O₃ Gen Ref reading, slowly rotate the lamp or move it back and forth vertically until the reading is at its maximum, above 1300 mV (replace lamp if highest possible reading falls below 1300 mV: Steps 1 thru 7 above).
10. Finish screwing in the UV lamp holder so that it is snug but not excessively tight.
11. Replace the analyzer's cover.
12. Perform a leak check (Section 5.6.4).

5.7 TROUBLESHOOTING

This contains methods for identifying the source of performance problems with the analyzer and procedures to service the instrument.



QUALIFIED PERSONNEL REQUIRED

The operations presented in this Section must be performed by qualified maintenance personnel only.



WARNING – Risk of Electrical Shock

Some operations require that the instrument be open and running. Exercise caution to avoid electrical shocks



CAUTION

Exercise caution to avoid electrostatic or mechanical damage to the analyzer.

Do not drop tools into the analyzer or leave those after your procedures.

Do not short or touch electric connections with metallic tools while operating inside the analyzer.

Use common sense when operating inside a running analyzer.

The analyzer has been designed so that problems can be rapidly detected, evaluated and repaired. During operation, it continuously performs diagnostic tests and provides the ability to evaluate its key operating parameters without disturbing monitoring operations.

A systematic approach to troubleshooting will generally consist of the following steps:

1. Note Alerts and take corrective action as necessary.
2. Examine the values of all parameter functions and compare them to factory values. Note any major deviations from the factory values and take corrective action.



3. Use the internal electronic status LEDs to determine whether the electronic communication channels are operating properly.
4. **SUSPECT A LEAK FIRST!**
 - Technical Support data indicate that the majority of all problems are eventually traced to leaks in the internal pneumatics of the analyzer or the diluent gas and source gases delivery systems.
 - Check for gas flow problems such as clogged or blocked internal/external gas lines, damaged seals, punctured gas lines, a damaged / malfunctioning pumps, etc.

5.7.1 FAULT DIAGNOSIS WITH ALERTS

The most common and/or serious instrument failures will result in a warning message, called an Alert. Table 5-3 lists some of the more common Alert messages, along with their meaning and recommended corrective action.

It should be noted that if more than two or three warning Alerts occur at the same time, it is often an indication that some fundamental analyzer sub-system has failed, rather than being an indication of the specific failures referenced by the warning Alerts.

Table 5-3. Alerts - Indicated Failures

ALERT	FAULT CONDITION	POSSIBLE CAUSES
PHOTO TEMP WARNING	The optical bench temperature lamp temp is $\geq 51^{\circ}\text{C}$.	<ul style="list-style-type: none"> • Bench lamp heater • Bench lamp temperature sensor • Relay controlling the bench heater • "Hot" Lamp
BOX TEMP WARNING	Box Temp is $< 5^{\circ}\text{C}$ or $> 48^{\circ}\text{C}$.	<ul style="list-style-type: none"> • Box Temperature typically runs $\sim 7^{\circ}\text{C}$ warmer than ambient temperature. • Poor/blocked ventilation to the analyzer • Stopped Exhaust-Fan • Ambient Temperature outside of specified range
CONFIG INITIALIZED	Configuration and Calibration data reset to original Factory state.	User erased data
DATA INITIALIZED	Data Storage in DAS was erased.	User cleared data.
LAMP STABIL WARN	Reference value is unstable.	<ul style="list-style-type: none"> • Faulty UV source lamp • Noisy UV detector • Faulty UV lamp power supply
SAMPLE FLOW WARN	Sample flow rate is < 500 cc/min or > 1000 cc/min.	<ul style="list-style-type: none"> • Failed Sample Pump • Blocked Sample Inlet/Gas Line • Dirty Particulate Filter • Leak downstream of Critical Flow Orifice • Failed Flow Sensor
SAMPLE PRES WARN	Sample Pressure is < 15 in-Hg or > 35 in-Hg Normally 29.92 in-Hg at sea level decreasing at 1 in-Hg per 1000 ft of altitude (with no flow – pump disconnected).	<p>If Sample Pressure is < 15 in-HG:</p> <ul style="list-style-type: none"> • Blocked Particulate Filter • Blocked Sample Inlet/Gas Line • Failed Pressure Sensor/circuitry <p>If Sample Pressure is > 35 in-HG:</p> <ul style="list-style-type: none"> • Bad Pressure Sensor/circuitry
SAMPLE TEMP WARN	Sample temperature is $< 10^{\circ}\text{C}$ or $> 50^{\circ}\text{C}$.	<ul style="list-style-type: none"> • Ambient Temperature outside of specified range • Failed Sample Temperature Sensor • Board controlling the Bench Heater



ALERT	FAULT CONDITION	POSSIBLE CAUSES
PHOTO REF WARNING	Occurs when Ref is <700 mVDC or >2900 mVDC.	<ul style="list-style-type: none"> • UV Lamp • UV Photo-Detector Preamp
O3 GEN TEMP WARNING	IZS Ozone Generator Temp is outside of control range of 48°C ± 3°C.	<ul style="list-style-type: none"> • No IZS option installed, instrument improperly configured • O₃ generator heater • O₃ generator temperature sensor • Board controlling the O₃ generator heater
SYSTEM RESET	The computer has rebooted.	<ul style="list-style-type: none"> • This message occurs at power on. • If it is confirmed that power has not been interrupted: • Fatal Error caused software to restart • Loose connector/wiring

5.7.2 FAULT DIAGNOSIS WITH DASHBOARD FUNCTIONS

In addition to being useful as predictive diagnostic tools, the functions viewable in the Dashboard can be used to isolate and identify many operational problems.

The acceptable ranges for these functions are listed in the “Nominal Range” column of the analyzer *Final Test and Validation Data Sheet* that was shipped with the instrument. Values outside these acceptable ranges indicate a failure of one or more of the analyzer’s subsystems. Functions whose values are still within the acceptable range but have significantly changed from the measurement recorded on the factory data sheet may also indicate a failure.

The following table contains some of the more common causes for these values to be out of range.

Table 5-4. Dashboard Functions - Indicated Failures

FUNCTIONS	INDICATED FAILURE(S)
RANGE	<p>Incorrectly configured measurement range(s) could cause response problems with a Data logger or chart recorder attached to one of the analog output.</p> <p>If the Range selected is too small, the recording device will over range.</p> <p>If the Range is too big, the device will show minimal or no apparent change in readings.</p>
O3 Stability	Indicates noise level of instrument or concentration of sample gas.
Photo Meas & Photo Ref	<p>If the value displayed is too high (the full-scale range of the detector is up to 2990mV), the UV Source has become brighter. If the Measure or Reference values are at 2990mV:</p> <p>If the value displayed is too low:</p> <ul style="list-style-type: none"> • < 100mV – Bad UV lamp or UV lamp power supply. • < 700mV – Lamp output has dropped; adjust or replace lamp. <p>If the value displayed is constantly changing:</p> <ul style="list-style-type: none"> • Bad UV lamp. • Defective UV lamp power supply. <p>If the Photo Ref value changes by more than 10mV between zero and span gas:</p> <ul style="list-style-type: none"> • Defective/leaking switching valve.
Sample Pressure	See Table 5-3 for SAMPLE PRES WARN.
Sample Flow	Check for gas flow problems (see Section 5.7.5).



N400

FUNCTIONS	INDICATED FAILURE(S)
Sample Temp	SAMPLE TEMP should be close to PHOTO BENCH TEMP. Temperatures outside of the specified range or oscillating temperatures are cause for concern.
Photo Lamp Temp	Bench temp control improves instrument noise, stability and drift. Temperatures outside of the specified range or oscillating temperatures are cause for concern. Table 5-3 for PHOTO TEMP WARNING.
Box Temp	If the box temperature is out of range, check fan in the power supply module. Areas to the side and rear of instrument should allow adequate ventilation. See Table 5-3 for BOX TEMP WARNING.
Lamp IZS Block Temp	If the O ₃ Generator Temperature is out of range, check the O ₃ Generator heater and temperature sensor. See Table 5-3 for O3 GEN TEMP WARNING
O3 Slope	Values outside range indicate Contamination of the zero air or span gas supply Instrument is miscalibrated Blocked gas flow Faulty sample pressure sensor (P1) or circuitry Bad/incorrect span gas concentration.
O3 Offset	Values outside range indicate Contamination of the zero air supply

5.7.3 THE DIAGNOSTIC SIGNAL I/O FUNCTION

The Utilities>Diagnostics menu provides a view of the digital and analog I/O signals in the analyzer. These signals, combined with a thorough understanding of the instrument's Theory of Operation (found in Section 6), are useful for troubleshooting in three ways:

- The technician can view the raw, unprocessed signal level of the analyzer's critical inputs and outputs.
- Many of the components and functions that are normally under algorithmic control of the CPU can be manually exercised.
- The technician can directly control the signal level Analog and Digital Output signals.

This allows the technician to observe systematically the effect of directly controlling these signals on the operation of the analyzer. Use the Utilities>Diagnostics menu to view the raw voltage of an input signal or the Setup menu to control the state of an output voltage or control signal.

5.7.4 FAULT DIAGNOSIS WITH BOARD LEDs

The following illustrations show connectors and LEDs that can indicate where issues may lie. Figure 5-8 shows the layout for the mainboard; Figure 5-9 shows the layout for the ozone brick module's smartboard.

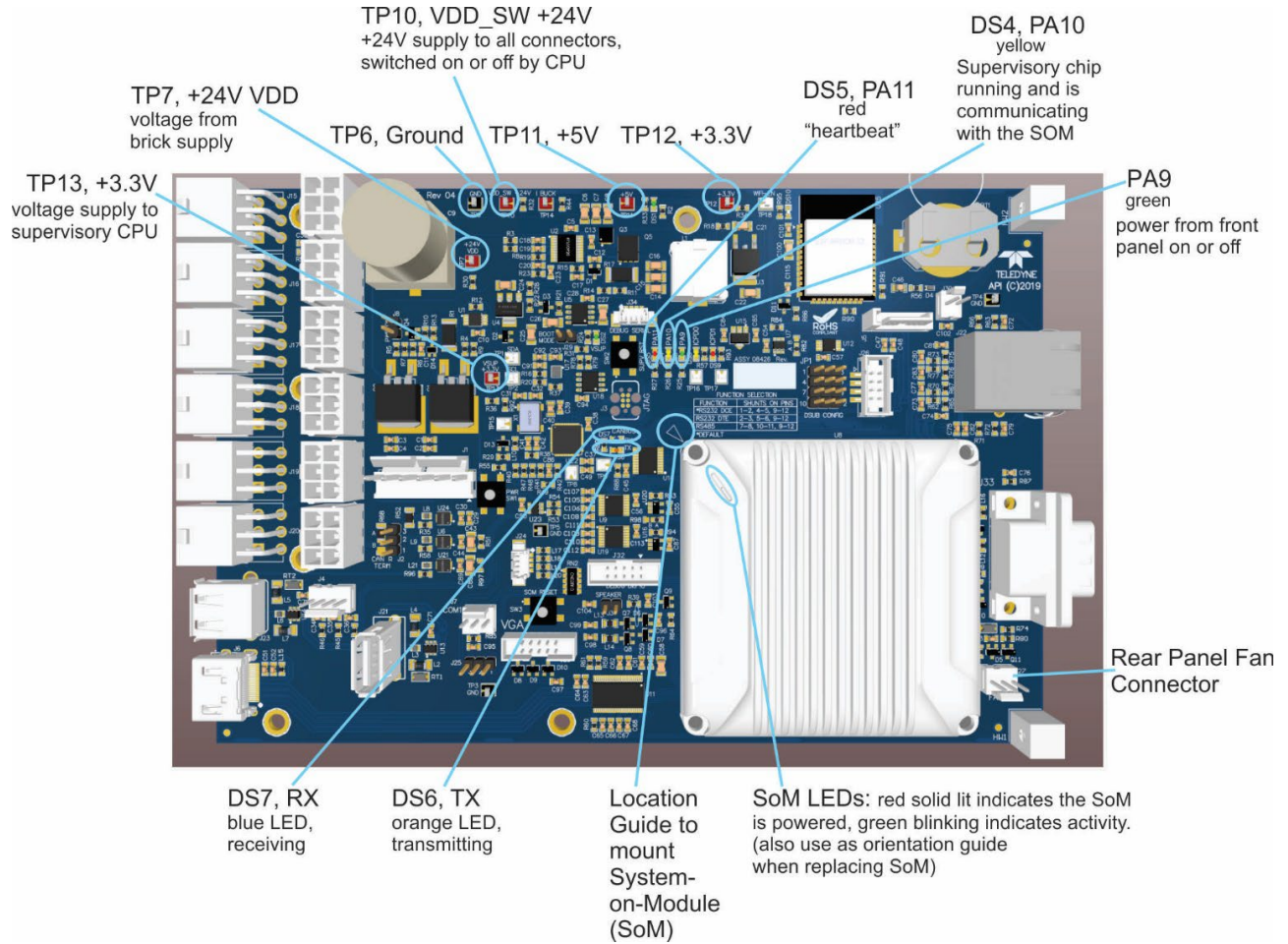

Figure 5-8. Mainboard

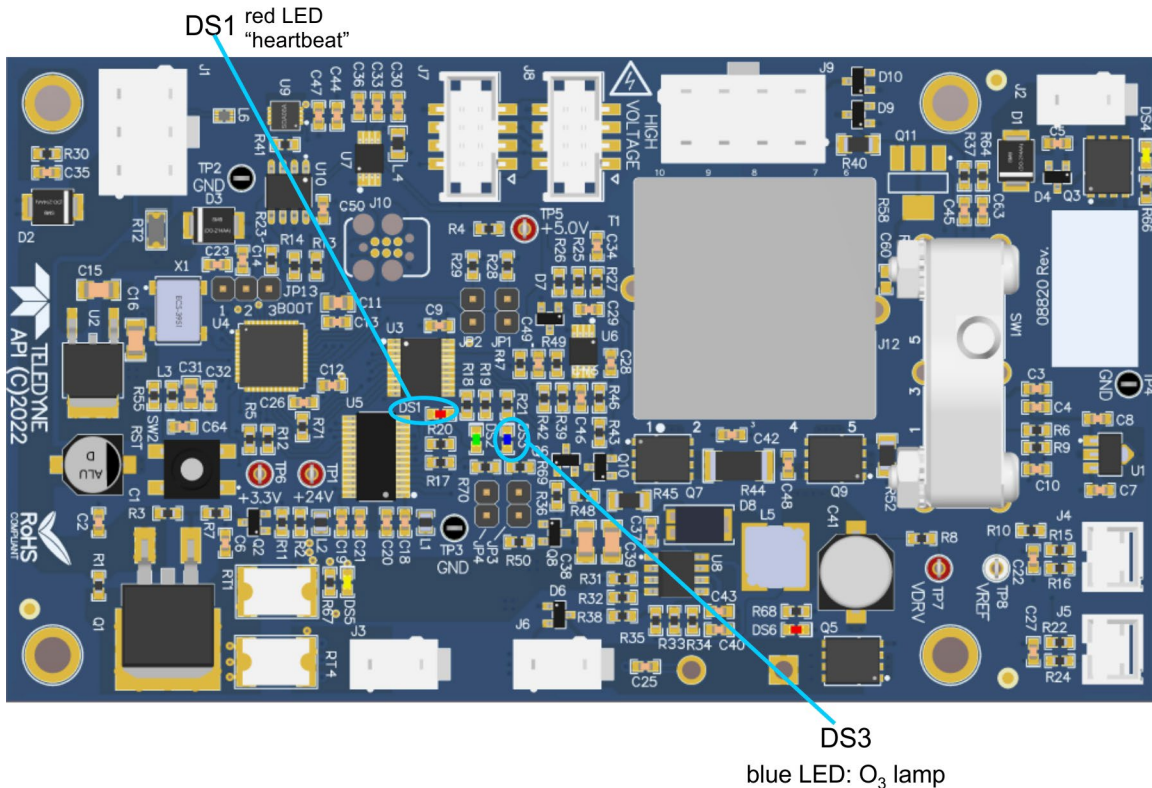

Figure 5-9. Ozone Sensor Board LEDs

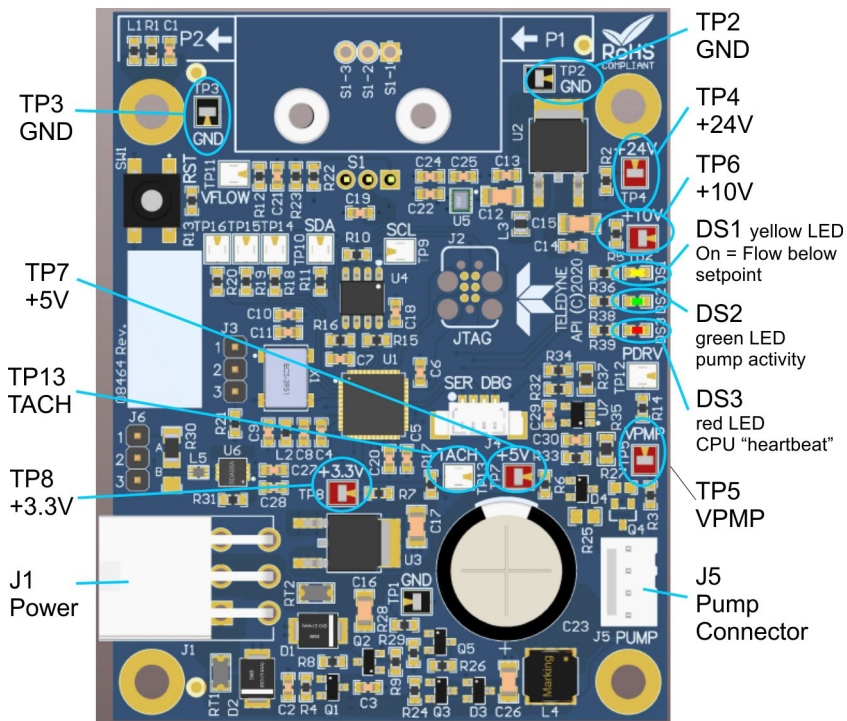

Figure 5-10. DC Pump Control Board LEDs

5.7.5 FLOW PROBLEMS

CAUTION



It is important that the sample airflow system is both leak tight and not pressurized over ambient pressure.

Regular leak checks should be performed on the analyzer as described in the maintenance schedule, Table 5-1.

Procedures for correctly performing leak checks are provided in Section 5.6.4, andj flow checks are provided in 5.6.5.

When troubleshooting flow problems, it is a good idea to first confirm that the actual flow and not the analyzer's flow sensor and software are in error, or the flow meter is in error. Use an independent, calibrated volumetric flow meter to perform a flow check as described in Section 5.6.5.

In general, flow problems can be divided into three categories:

- Flow is zero (no flow).
- Flow is greater than zero, but is too low, and/or unstable.
- Flow is too high .

When troubleshooting flow problems, it is crucial to confirm the actual flow rate without relying on the analyzer's flow display. The use of an independent, external flow meter as described above is essential.

The flow diagrams found in Section 2.3.3 can help in trouble-shooting flow problems.

5.7.5.1 FLOW IS ZERO

This is when the unit displays a SAMPLE FLOW Alert, or the SAMPLE FLOW function reports a zero or very low flow rate. The instrument has a controlled HD pump (Figure 5-11) which controlled by the pump PCA (see Figure 5-10 for LED descriptions and Figure 5-14 for connectors).

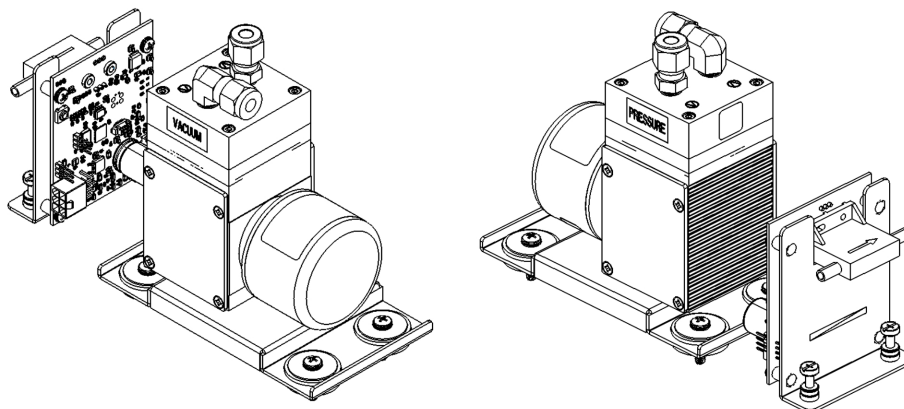

Figure 5-11. HD non-PID Controlled Pump



Confirm that the sample pump is operating (turning). If not, use a DC voltmeter to make sure that power is being supplied to the pump if no power is present at the electrical leads of the pump.

1. Check that the communication/activity LEDs on the pump board (Figure 5-10) are illuminated and/or blinking. If not, check power to board via its test points.
2. If pump board LEDs are active and pump is not operating, check the "Pump Control Mode" VAR and make sure its setting is Constant for this HD flow-controlled pump.
3. Check flow calibration (Section 4.5.2).
4. If DC power is being supplied to the pump, but it is not turning, replace the pump module; refer to Figure 5-14 for control board connectors.
5. If the pump is operating but the unit reports no gas flow, perform a flow check as described in Section 5.6.5.
6. If no independent flow meter is available:
 - Disconnect the gas lines from both the sample inlet and the exhaust outlet on the rear panel of the instrument.
 - Make sure that the unit is in basic Sample Mode.
 - Place a finger over an Exhaust outlet on the rear panel of the instrument.
 - If gas is flowing through the analyzer, you will feel pulses of air being expelled from the Exhaust outlet.
7. If gas flows through the instrument when it is disconnected from its sources of zero air, span gas or sample gas, the flow problem is most likely not internal to the analyzer. Check to make sure that:
 - All calibrators/generators are turned on and working correctly.
 - Gas bottles are not empty or low.
 - Valves, regulators and gas lines are not clogged or dirty.

5.7.5.2 LOW FLOW

1. Check flow calibration (Section 4.5.2).
2. Check if the pump diaphragm is in good condition. If not, rebuild the pump (see Section 5.6.2). Check with Technical Support for information on pump rebuild kits.
3. Check for leaks as described in Section 5.6.3. Repair the leaking fitting, line or valve and re-check.
4. Check the sample filter and the orifice filter for dirt. Replace filters (see 5.6.1).
5. Check for partially plugged pneumatic lines, or valves. Clean or replace them.
6. Check for plugged or dirty critical flow orifices. Replace them.
7. If an IZS option is installed in the instrument, press CALZ and CALS. If the flow increases, then suspect a bad sample/cal valve.

5.7.5.3 HIGH FLOW

The most common cause of high flow is a leak in the sample flow control assembly or between there and the pump. If no leaks or loose connections are found in the fittings or the gas line between the orifice and the pump, replace the critical flow orifice (s) inside the sample flow control assembly.



5.7.5.4 ACTUAL FLOW DOES NOT MATCH DISPLAYED FLOW

If the actual flow measured does not match the displayed flow, but is within the limits of 720-880 cm³/min, adjust the calibration of the flow measurement as described in Section 5.6.5.

5.7.5.5 SAMPLE PUMP

The sample pump should start shortly after the the instrument is powered up and all modules have been initiated; it requires no additional waiting time as it runs at 100% constant flow, pulling against an orifice for flow control.

With the Sample Inlet plugged, the Pressure reading should be about 10 in-Hg for a pump that is in good condition. The pump may need to be replaced if the reading is above 10 in-Hg. If the Sample Flow reading is greater than 10 cm³/min there is a leak in the pneumatic lines.

5.7.6 CALIBRATION PROBLEMS

5.7.6.1 MISCALIBRATED

There are several symptoms that can be caused by the analyzer being miscalibrated. This condition is indicated by out-of-range Slopes and Offsets as displayed through the test functions and is frequently caused by the following:

- Contaminated span gas. This can cause a large error in the slope and a small error in the offset. Span gas contaminated with a major interferent such as Mercury Vapor, will cause the analyzer to be calibrated to the wrong value. Also, could be caused if the span gas concentration entered into the analyzer during the calibration procedure is not the precise concentration value of the gas used.
- Contaminated zero gas. This can cause either a positive or negative offset and will indirectly affect the slope. If contaminated with O₃, it will cause a positive offset.
- Dilution calibrator not set up correctly or is malfunctioning. This will also cause the slope, but not the zero, to be incorrect. Again, the analyzer is being calibrated to the wrong value.
- Too many analyzers on the manifold. This can cause either a slope or offset error because ambient gas with its pollutants will dilute the zero or span gas.

5.7.6.2 NON-REPEATABLE ZERO AND SPAN

As stated earlier, leaks both in the N400 and in the external system are a common source of unstable and non-repeatable readings.

- Check for leaks in the pneumatic systems as described in Section 5.6.3. Also consider pneumatic components in the gas delivery system outside the analyzer such as:
- A change in zero air source such as ambient air leaking into zero air line, or;
- A change in the span gas concentration due to zero air or ambient air leaking into the span gas line.
- Once the instrument passes a leak check, perform a flow check (see Section 5.6.5) to make sure adequate sample is being delivered to the sensor assembly.



- Confirm the sample pressure, sample temperature, and sample flow readings are correct and have steady readings.
- Verify that the sample filter element is clean and does not need to be replaced.

5.7.6.3 INABILITY TO SPAN – NO SPAN BUTTON (CAL5)

- Confirm that the O₃ span gas source is accurate. This can be done by inter-comparing the source with another calibrated monitor, or by having the O₃ source verified by an independent traceable photometer.
- Check for leaks in the pneumatic systems as described in Section 5.6.3.
- Make sure that the expected span gas concentration entered into the instrument during calibration is the correct span gas concentration and not too different from expected span value.
- Check to make sure that there is no ambient air or zero air leaking into span gas line.

5.7.6.4 INABILITY TO ZERO – NO ZERO BUTTON (CALZ)

- Confirm that there is a good source of zero air. If the IZS option is installed, compare the zero reading from the IZS zero air source to the calibration zero air source.
- Check for leaks in the pneumatic systems as described in 5.6.3.
- Check to ensure that there is no ambient air leaking into zero air line.

5.7.7 OTHER PERFORMANCE PROBLEMS

Dynamic problems (i.e. problems which only manifest themselves when the analyzer is monitoring sample gas) can be the most difficult and time consuming to isolate and resolve. The following provides an itemized list of the most common dynamic problems with recommended troubleshooting checks and corrective actions.

5.7.8 TEMPERATURE PROBLEMS

Individual control loops are used to maintain the set point of the UV Lamp, IZS Ozone Generator (Optional) and Metal Wool Scrubber (Optional) temperatures. If any of these temperatures are out of range or are poorly controlled, the N400 will perform poorly.

5.7.8.1 BOX TEMPERATURE

View the Box Temp signal using the signal voltage in the Utilities>Diagnostics>Analog Inputs menu (Section 5.7.3). This parameter will vary with ambient temperature, but at ~30°C (6-7° above room temperature) the signal should be ~1450 mV.

5.7.8.2 SAMPLE TEMPERATURE

Sample Temperature should read approximately 5.0°C higher than the box temperature.



N400

5.7.8.3 UV LAMP TEMPERATURE

Some possible causes for the UV Lamp temperature to have failed could be that the lamp heater has failed.

5.7.8.4 IZS OPTION OZONE GENERATOR TEMPERATURE

Some possible causes for the Ozone Generator temperature to have failed could be that the O₃ Gen heater has failed.

5.7.9 SUBSYSTEM CHECKOUT

The preceding content discussed a variety of methods for identifying possible sources of failures or performance problems within the analyzer. This section describes how to determine whether an individual component or subsystem is the cause of the problem being investigated.

5.7.9.1 AC MAIN POWER



WARNING – ELECTRICAL SHOCK HAZARD

Should the AC power circuit breaker trip, investigate and correct the condition causing this situation before turning the analyzer back on.



The instrument's electronic systems will operate with any of the specified power specifications listed in Table 1-1 and will power on when the rear panel Hard Power switch is placed in the ON position. (If the power source is disrupted, the instrument will turn on once the power is restored). If the instrument doesn't start, check the following possible causes and possible solutions:

- Check the power cord for damage, such as whether it's cut or burned.
- Check that the power cord is adequately rated for the instrument's specified power rating.
- Check that the power source is of the proper voltage for the instrument's specified power rating.
- Note whether the instrument had been opened for maintenance; if so, place the rear panel Hard Power switch in the OFF position, and disconnect the power cord; then reopen the instrument and check that no wiring had been dislodged and that no tools were left inside.
- If the preceding checks reveal no cause, then check the fuse with an ohmmeter to determine its viability: carefully follow the instructions in Section 5.8.1 to remove the fuse for testing.
 - If the fuse is blown, replace it with a fuse of the correct specifications as instructed in Section 5.8.1.
 - If the fuse is not blown, or if the replacement fuse blows, then call Technical Support (Section 5.10).
- Last, check that the cable running from the power supply is properly seated in its connector at J1 on the Mainboard (Figure 5-13), and use a voltmeter to check TP7 on the Mainboard (Figure 5-8).

5.7.9.2 LCD DISPLAY MODULE

Verify the functioning of the front panel display by observing it when power is applied to the instrument. Assuming that there are no wiring problems and that the DC power supplies are operating properly, the display screen should light and show the splash screen with logo and other indications of its state as the CPU goes through its initialization process.

5.7.9.3 RS-232 COMMUNICATIONS

Teledyne API analyzers use the RS-232 communications protocol to allow the instrument to be connected to a variety of computer-based equipment. Problems with RS-232 connections usually center around such things as incorrect connector configuration or incorrect software settings. Do not do anything inside the instrument without first contacting Technical Support (Section 5.10). For additional information, see Section 2.3.1.4 under "Serial Connection."

5.7.10 TROUBLESHOOTING THE PHOTOMETER

This section involves checking the measure/reference valve and the photometer UV lamp power supply.

5.7.10.1 CHECKING THE MEASURE/REFERENCE VALVE

To check the function of the photometer's measure / reference valve:

1. View the Photo Ref function in the Dashboard (Setup>Dashboard to configure).
2. Follow the instruction in Section 4.2.1.1 for performing a zero-point calibration check.
 - Press ZERO and allow the analyzer to stabilize.
3. Note the displayed value.
4. Follow the instruction in Section 4.2.1.2 for performing a span point calibration check.
 - Press SPAN and allow the analyzer to stabilize.
5. Note the displayed value for Photo Ref.
 - If the PHOTO REF value has decreased by more than 2 mV from its value with zero gas, then there is a "cross-port" leak in the M/R valve or a bad O₃ reference scrubber. Refer to Section 5.8.2.1 for replacement instructions.
 - Press the EXIT button to interrupt the span point calibration process (DO NOT PRESS the ENTR button).

5.8 SERVICE PROCEDURES

This section contains procedures that might need to be performed on rare occasions when a major component of the analyzer requires repair or replacement.

Note

Regular maintenance procedures are discussed in Section 5.6 and are not listed here). Also, there may be more detailed service notes for some of the below procedures. Contact Teledyne API's Technical Support Department (Section 5.10).

WARNING – Electrical Shock Hazard



Unless the procedure being performed requires the instrument to be operating, turn it off and disconnect power before opening the analyzer and removing, adjusting or repairing any of its components or subsystems.

Caution – Qualified Technician



The operations outlined in this chapter are to be performed by qualified maintenance personnel only.

5.8.1 REPLACING THE FUSE

ATTENTION

COULD DAMAGE INSTRUMENT AND VOID WARRANTY
Fuses do not typically fail without definite cause. Do not attempt to replace until after all measures to detect the cause of a power failure, have been carried out, including Soft Power switch LED not lit (neither solid nor blinking), but Hard Power switch is in ON position and instrument's power cord properly connected at both ends. If an ohmmeter shows that the fuse is good, or if a new fuse blows, call Technical Support (Section 5.10).

WARNING – ELECTRICAL SHOCK HAZARD



Never pull out fuse drawer without ensuring that the Hard Power switch is in OFF position and power cord disconnected, to ensure there is no power to the instrument before checking/changing fuse.

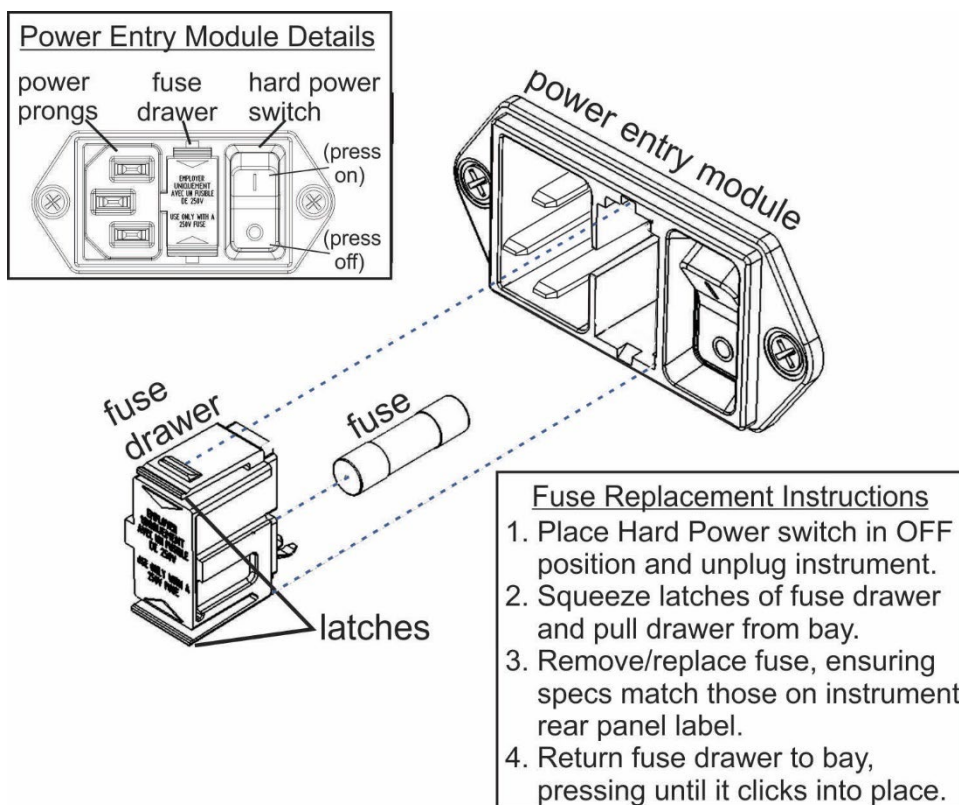

Figure 5-12. Fuse Access

5.8.2 REPLACING A MODULE

Each smart module has its own printed circuit board mounted to it so that the entire assembly can be quickly and efficiently swapped out:

1. Turn off the analyzer power (noting that the front panel switch LED should either be blinking or solid off before powering down via the rear panel switch).
2. Remove the power cord and the analyzer cover.
3. Disconnect tubing connected to the module.
4. Unplug the electrical connection to the module.
5. Unscrew the mounting screws that attach the module to the chassis and lift out the entire assembly.
6. If you received a complete replacement module with circuit board and mounting bracket attached, simply reverse the above steps to install.

Note

Ensure to carry out a leak check (Section 5.6.4) and a recalibration after the analyzer has warmed up for about 60 minutes.

5.8.2.1 CONNECTORS ON MAINBOARD

Modules can be connected to any of the Mainboard's six CANBUS connectors.

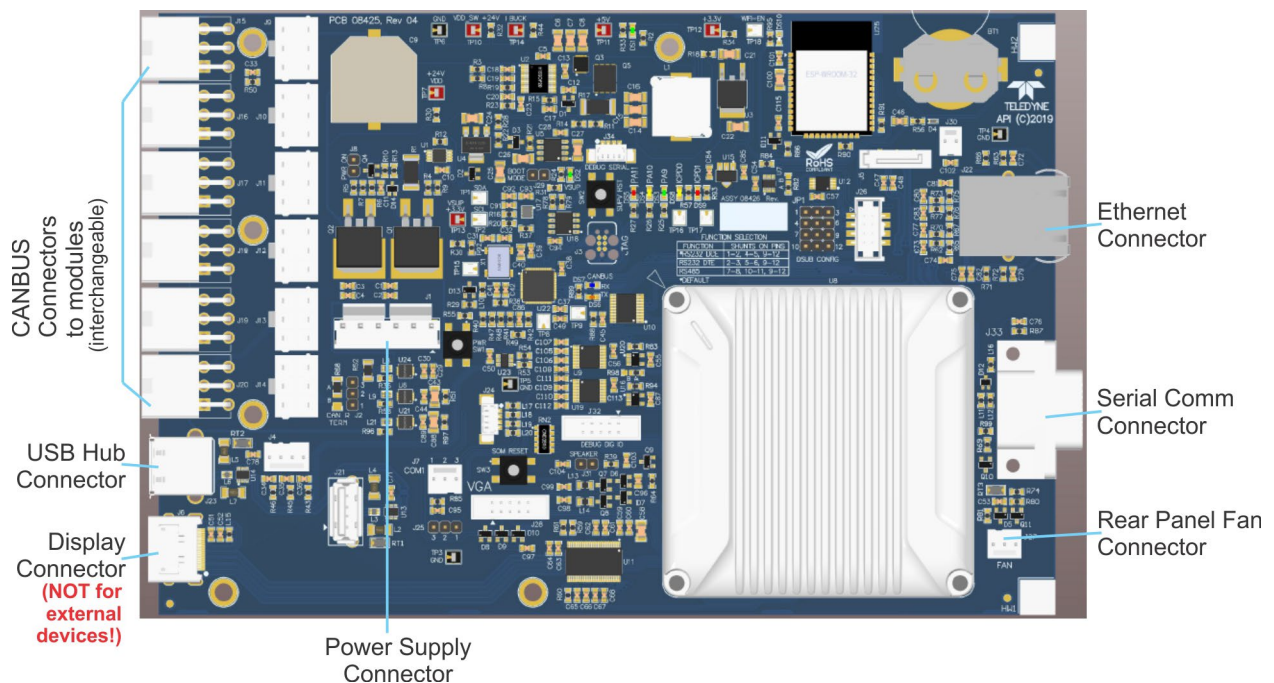

Figure 5-13. Mainboard Connectors

5.8.2.2 CONNECTORS ON DC PUMP PCA

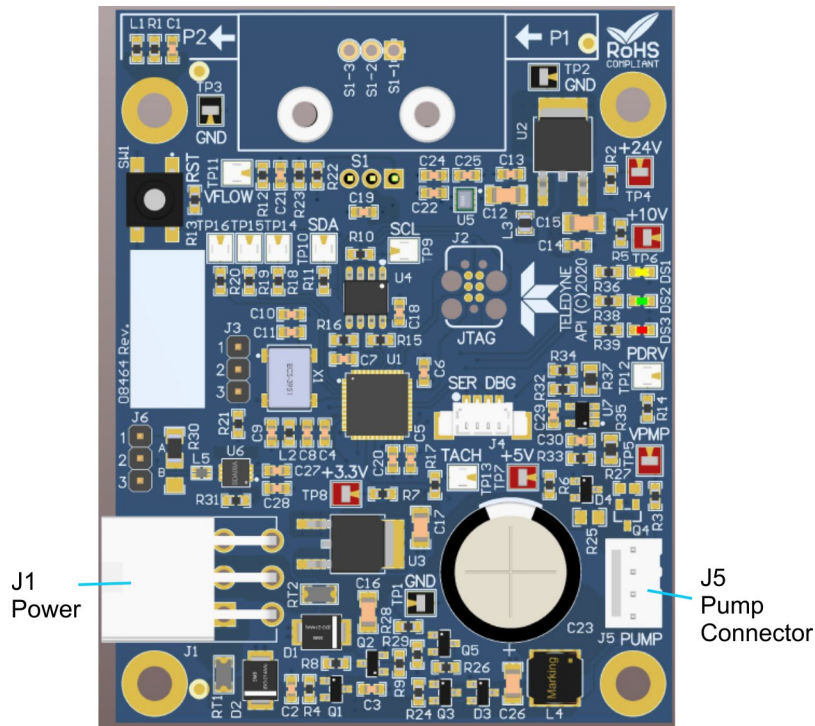

Figure 5-14. DC Pump Control Board Connectors

5.8.2.3 CONNECTORS ON OZONE GENERATOR LAMP PCA

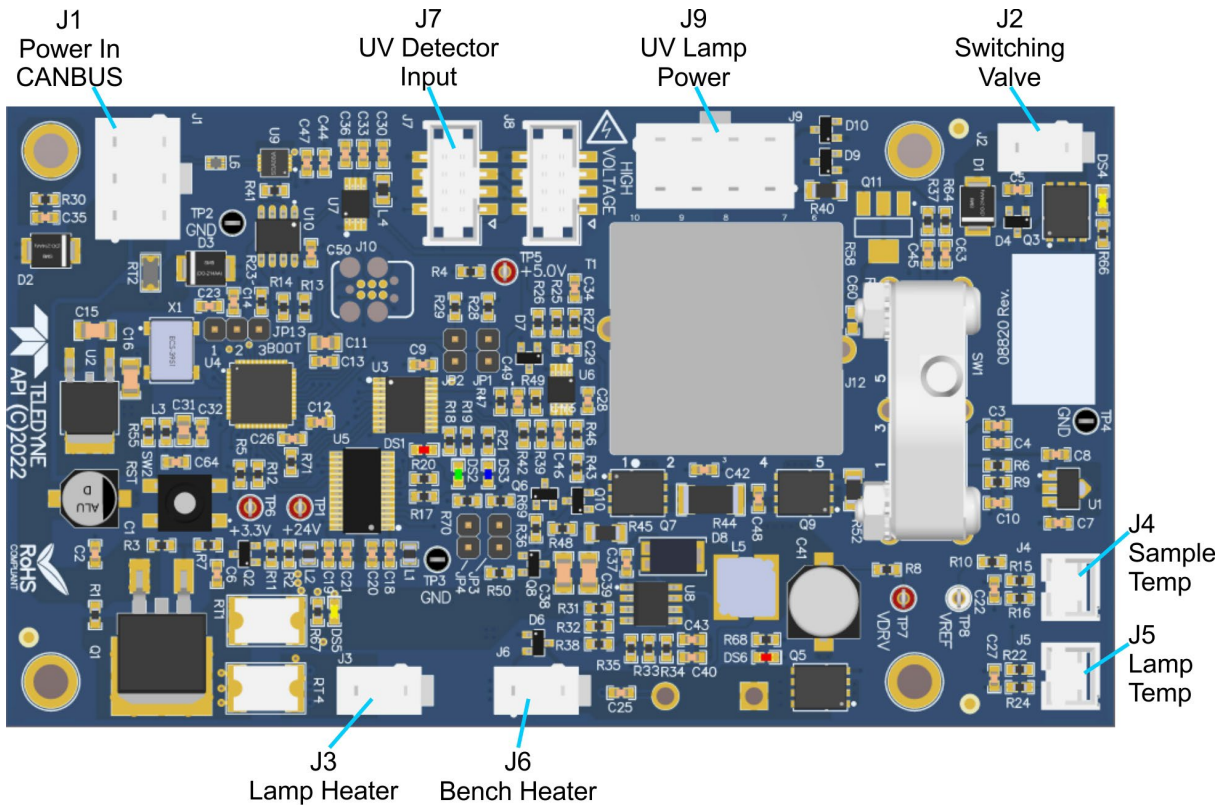

Figure 5-15. Ozone Generator Lamp PCA

5.8.2.4 CONNECTOR ON OZONE GENERATOR UV DETECTOR

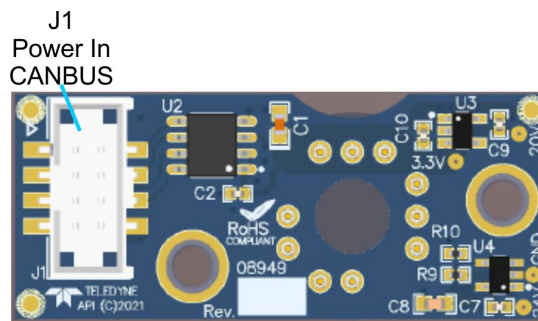

Figure 5-16. Ozone Generator UV Detector PCA

5.8.3 REPLACING THE STANDARD REFERENCE O₃ SCRUBBER

When the reference O₃ scrubber requires replacement:

1. Turn off power to the instrument.
2. Remove instrument cover.
3. The reference scrubber is a blue colored canister located at the rear of the measure/reference valve assembly.
4. Disconnect the top 1/8" brass tube fitting from the scrubber.

5. Carefully remove the scrubber from the retaining clip.
6. Remove the bottom 1/8" brass tube fitting from the scrubber.
7. Perform the above steps in reverse to install the new scrubber.
8. Run the instrument for at least 24 hours with the new scrubber installed, and recalibrate the instrument.

5.8.4 REPLACING THE IZS O₃ SCRUBBER

1. Turn off power to the instrument.
2. Remove instrument cover.
3. The IZS zero air scrubber is attached to the brass elbow inlet fitting on the top of the O₃ generator assembly. See Figure 5-17.
4. Disconnect 1/4" Tube Fitting nut on O₃ generator inlet fitting.
5. Disconnect 1/8" tube fitting on the other end of the scrubber.
6. Remove the scrubber and install new scrubber
7. Reassemble by reversing these steps.

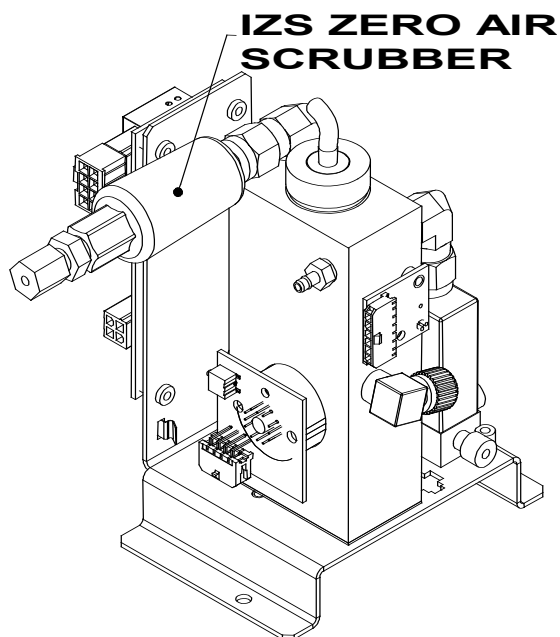

Figure 5-17. IZS O₃ Generator Zero Air Scrubber Location

5.8.5 REPLACING THE METAL WOOL SCRUBBER OPTION

Please contact Teledyne API's Technical Support for this procedure.



5.9 FREQUENTLY ASKED QUESTIONS

The following is a list from the Teledyne API's Technical Support Department of the most commonly asked questions relating to this analyzer.

QUESTION	ANSWER
Why is the ZERO or SPAN button not displayed during calibration?	This happens when the measured gas concentration differs significantly from the span or zero gas concentration value entered by the user. This prevents accidental recalibration of the analyzer to an out-of-range response curve. EXAMPLE: The span set point is 40 ppm but gas concentration being measured is only 5 ppm. For more information, see Sections 5.7.6.3 and 5.7.6.4.
How do I enter or change the value of my Span Gas?	See Section 4.2.1.2.
Why does the analyzer not respond to span gas?	There could be something wrong with a span gas tank, or a span gas concentration was entered incorrectly, or there could be a pneumatic leak. Section 5.7.6.3 addresses these issues.
Is there an optional midpoint calibration?	Midpoint calibration checks can be performed using the instrument's AutoCal feature. The IZS option is required in order to perform a mid-point span check.
What do I do if the concentration displayed does not match the value recorded or displayed on my data logger even if both instruments are calibrated?	This most commonly occurs when an independent metering device is used besides the data logger/recorder to determine gas concentration levels while calibrating the analyzer. These disagreements result from the analyzer, the metering device and the data logger having slightly different ground levels.
How do I perform a leak check?	Section 5.6.3 provides leak check instructions.
How do I measure the sample flow?	Sample flow is measured by attaching a calibrated rotameter, wet test meter, or other flow-measuring device to the sample inlet port when the instrument is operating. The sample flow should be 800 cm ³ /min ±10%. See Section 5.6.5.
How long does the UV source last?	Typical lifetime is about 2-3 years.
Can I automate the calibration of my analyzer?	Any analyzer with zero/span valve or IZS option can be automatically calibrated using the instrument's AutoCal feature (Section 4.3).
Can I use the IZS option to calibrate the analyzer?	Yes. However, whereas this may be acceptable for basic calibration checks, the IZS option is not as accurate as the external span and zero gas bottles. To achieve highest accuracy, it is recommended to use cylinders of calibrated span gases in combination with a zero air source.



N400

5.10 TECHNICAL ASSISTANCE

If this manual and its troubleshooting / repair sections do not solve your problems, technical assistance may be obtained from:

Teledyne API Technical Support
9970 Carroll Canyon Road
San Diego, California 92131-1106 USA

Toll-free Phone: +1 800-324-5190

Phone: +1 858-657-9800

Fax: +1 858-657-9816

Email: api-techsupport@teledyne.com

Website: <http://www.teledyne-api.com/>

Before contacting Teledyne API Tech Support, please fill out the problem report form, available online for electronic submission at <http://www.teledyne-api.com>.



6. THEORY OF OPERATION

The Model N400 ozone analyzer is a microprocessor-controlled analyzer that determines the concentration of Ozone (O_3) in a sample gas drawn through the instrument. It requires that sample and calibration gasses be supplied at ambient atmospheric pressure in order to establish a stable gas flow through the absorption tube where the gas' ability to absorb ultraviolet (UV) radiation of a certain wavelength (in this case 254 nm) is measured.

Calibration of the instrument is performed in software and does not require physical adjustments to the instrument. During calibration, the microprocessor measures the current state of the UV Sensor output and various other physical parameters of the instrument and stores them in memory.

The microprocessor uses these calibration values, the UV absorption measurements made on the Sample Gas in the absorption tube along with data regarding the current temperature and pressure of the gas to calculate a final O_3 concentration.

This concentration value and the original information from which it was calculated are stored in the unit's internal data acquisition system (DAS).

6.1 MEASUREMENT METHOD

This Section presents measurement principles and fundamentals for this instrument.



6.1.1 CALCULATING O₃ CONCENTRATION

The basic principle by which the analyzer works is called the Beer-Lambert Law or Beer's Law. It defines how light of a specific wavelength is absorbed by a particular gas molecule over a certain distance. The mathematical relationship among these three parameters is:

Equation 6-1

$$I = I_0 e^{-\alpha Lc}$$

Where:

I₀ is the intensity of the light if there was no absorption.

I is the intensity with absorption.

e is the mathematical constant (Euler's number)

L is the absorption path, or the distance the light travels as it is being absorbed.

C is the concentration of the absorbing gas (in the case of the N400, Ozone (O₃)).

α is the absorption coefficient that tells how well O₃ absorbs light at the specific wavelength of interest.

To solve this equation for **C**, the concentration of the absorbing Gas (in this case O₃), the application of a little algebra is required to rearrange the equation as follows:

Equation 6-2

$$C = \ln\left(\frac{I_0}{I}\right) \times \left(\frac{1}{\alpha L}\right) \quad \text{at STP}$$

Unfortunately, both ambient temperature and pressure influence the density of the sample gas and therefore the number of ozone molecules present in the absorption tube thus changing the amount of light absorbed.

In order to account for this effect the following addition is made to the equation:

Equation 6-3

$$C = \ln\left(\frac{I_0}{I}\right) \times \left(\frac{1}{\alpha L}\right) \times \left(\frac{T}{273K} \times \frac{29.92 \text{ inHg}}{P}\right)$$

Where:

T = sample temperature in Kelvin

P = sample pressure in inches of mercury

Finally, to convert the result into parts per billion (PPB), the following change is made:

Equation 6-4

$$C = \ln\left(\frac{I_0}{I}\right) \times \left(\frac{10^{-9}}{\alpha L}\right) \times \left(\frac{T}{273K} \times \frac{29.92 \text{ inHg}}{P}\right)$$

Briefly, the Model N400 Ozone Analyzer:

- Measures each of the above variables: sample temperature; sample pressure; the intensity of the UV light beam with and without O₃ present,
- Inserts known values for the length of the absorption path and the absorption coefficient, and
- Calculates the concentration of O₃ present in the sample gas.

6.1.2 THE PHOTOMETER UV ABSORPTION PATH

In the most basic terms, the photometer of the Model N400 uses a high energy, mercury vapor lamp to generate a beam of UV light. This beam passes through a window of material specifically chosen to be both non-reactive to O₃ and transparent to UV radiation at 254nm and into an absorption tube filled with Sample Gas.

Because ozone is a very efficient absorber of UV radiation the absorption path length required to create a measurable decrease in UV intensity is short enough (approximately 42 cm) that the light beam is only required to make one pass through the absorption tube. Therefore, no complex mirror system is needed to lengthen the effective path by bouncing the beam back and forth.

Finally, the UV then passes through similar window at the other end of the absorption tube and is detected by a specially designed vacuum diode that only detects radiation at or very near a wavelength of 254nm. The specificity of the detector is high enough that no extra optical filtering of the UV light is needed.

The detector assembly reacts to the UV light and outputs a voltage that varies in direct relationship with the light's intensity. This voltage is digitized and sent to the instrument's CPU to be used in computing the concentration of O₃ in the absorption tube.

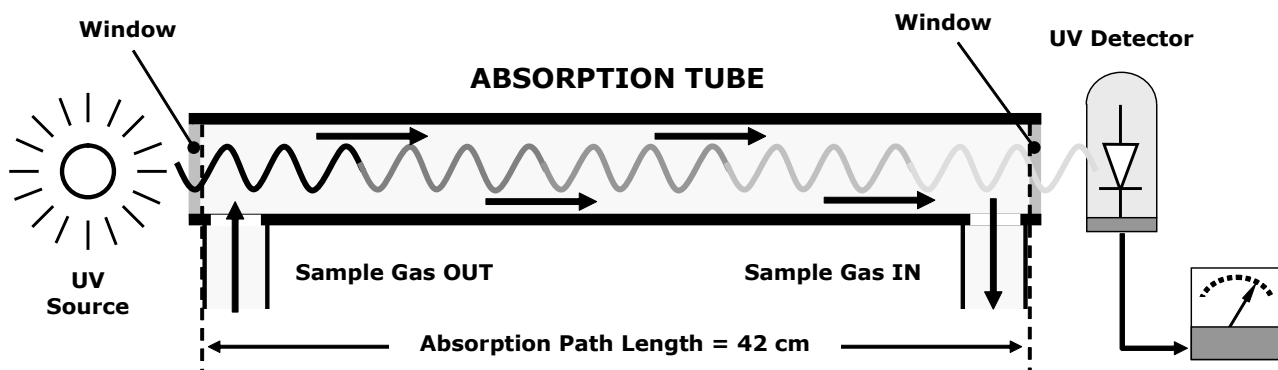

Figure 6-1. O₃ Absorption Path



6.1.3 THE REFERENCE / MEASUREMENT CYCLE

In order to solve the Beer-Lambert equation (see Section 6.1.1), it is necessary to know the intensity of the light passing through the absorption path both when O₃ is present and when it is not. The Model N400 accomplishes this by alternately sending the sample gas directly to the absorption tube and passing it through a chemical scrubber that removes any O₃ present; the measurement at this point is called the Reference.

The full Measurement/Reference (M/R) Cycle takes 8 seconds, during which the following take place:

- M/R Valve opens to the Measure path.
- Wait Period ensures that the Absorption tube has been adequately flushed of any previously present gasses.
- Analyzer measures the average UV light intensity of O₃-bearing Sample Gas (I) during this period.
- M/R Valve opens to the Reference path.
- Wait Period ensures that the Absorption tube has been adequately flushed of O₃ bearing gas.
- Analyzer measures the average UV light intensity of non-O₃-bearing Sample Gas (I₀) during this period.

6.1.4 INTERFERENT REJECTION

The detection of O₃ is subject to interference from a number of sources including: SO₂, NO₂, NO, H₂O, aromatic hydrocarbons such as meta-xylene and mercury vapor. The Model N400's basic method of operation successfully rejects interference from most of these molecules.

The O₃ scrubber located on the reference path is specifically designed ONLY to remove O₃ from the sample gas. Thus, the variation in intensities of the UV light detected during the instrument's measurement phase versus the reference phase is ONLY due to the presence or absence of O₃. Thus, the effect of interferents on the detected UV light intensity is ignored by the instrument.

Even if the concentration of interfering gases were to fluctuate so wildly as to be significantly different during consecutive reference and measurement phases, this would only cause the O₃ concentration reported by the instrument to become noisy. The average of such noisy readings would still be a relatively accurate representation of the O₃ concentration in the sample gas.

The Model N400 very effectively rejects interferences from SO₂, NO₂, NO and H₂O. The two types of interferents that may cause problems for the Model N400 are aromatic hydrocarbons and mercury vapor.

6.1.4.1 AROMATIC HYDROCARBONS

While the instrument effectively rejects interference from meta-xylene, it should be noted that there are a very large number of volatile aromatic hydrocarbons that could potentially interfere with ozone detection. This is particularly true of hydrocarbons with higher molecular weights. If the Model N400 is installed in an environment where high aromatic hydrocarbon concentrations are suspected, specific tests should be conducted to reveal the amount of interference these compounds may be causing.

6.1.4.2 MERCURY VAPOR

Mercury vapor absorbs radiation in the 254nm wavelength so efficiently that its presence, even in small amounts, will reduce the intensity of UV light to almost zero during both the Measurement and Reference Phases rendering the analyzer useless for detecting O₃.

If the Model N400 is installed in an environment where the presence of mercury vapor is suspected, specific steps **MUST** be taken to remove the mercury vapor from the sample gas before it enters the analyzer.

6.2 PNEUMATIC OPERATION

CAUTION



It is important that the sample airflow system is both leak tight and not pressurized over ambient pressure.

Regular leak checks should be performed on the analyzer as described in the maintenance schedule, Table 5-1.

Procedures for correctly performing leak checks can be found in Section 5.6.3.

6.2.1 SAMPLE GAS AIR FLOW

The flow of sample gas through the N400 analyzer (refer to pneumatic flow diagrams in Section 2.3.3) is produced by an internal pump that draws a small vacuum on the downstream side of a critical flow orifice, thereby creating a controlled airflow through the analyzer's absorption tube and other components. This requires the analyzer gas inlets be at or near ambient pressure usually managed by placing a vent line on the incoming gas line (see connections in Section 2.3.2).

By placing the pump down stream from the sample chamber, several problems are avoided.

- First, the pumping process heats and compresses the sample air complicating the measurement process.
- Additionally, certain physical parts of the pump itself are made of materials that might chemically react with the sample gas.
- Finally, in certain applications where the concentration of the target gas might be high enough to be hazardous, maintaining a negative gas pressure relative to ambient means that should a minor leak occur, no sample gas would be pumped into the atmosphere surrounding analyzer.

6.2.2 FLOW RATE CONTROL

To maintain a constant flow rate of the sample gas through the instrument, the N400 uses a special flow control assembly located downstream from the absorption tube and in the exhaust gas line just before the pump (see Figure 10-7). This assembly consists of:

- A critical flow orifice.
- Two o-rings: Located just before and after the critical flow orifice, the o-rings seal the gap between the walls of assembly housing and the critical flow orifice.
- A spring: Applies mechanical force needed to form the seal between the o-rings, the critical flow orifice and the assembly housing.

The critical flow orifice is the most important component of this flow control assembly is the critical flow orifice.

Critical flow orifices are a remarkably simple way to regulate stable gas flow rates. They operate without moving parts by taking advantage of the laws of fluid dynamics. By restricting the flow of gas through the orifice, a pressure differential is created. This pressure differential combined with the action of the analyzer's pump draws the gas through the orifice.

As the pressure on the downstream side of the orifice (the pump side) continues to drop, the speed that the gas flows through the orifice continues to rise. Once the ratio of upstream pressure to downstream pressure is greater than 2:1, the velocity of the gas through the orifice reaches the speed of sound. As long as that ratio stays at least 2:1, the gas flow rate is unaffected by any fluctuations, surges, or changes in downstream pressure because such variations only travel at the speed of sound themselves and are therefore cancelled out by the sonic shockwave at the downstream exit of the critical flow orifice.

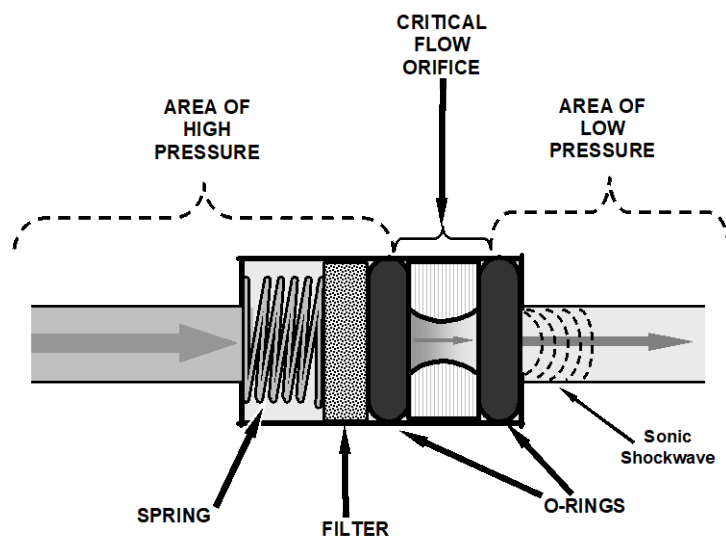

Figure 6-2. Flow Control Assembly & Critical Flow Orifice

The actual flow rate of gas through the orifice (volume of gas per unit of time), depends on the size and shape of the aperture in the orifice. The larger the hole, the more gas molecules (moving at the speed of sound) pass through the orifice. Using this critical flow orifice design extends the useful life of the pump. Once the pump degrades to the



point where the sample-to-vacuum-pressure ratio is less than 2:1, a critical flow rate can no longer be maintained.

6.2.3 PARTICULATE FILTER

The N400 Ozone Analyzer comes optionally equipped with either a 47 mm diameter Teflon particulate filter with a 5 micron pore size or a long-life DFU filter with 0.01 micron pore size. The filter is accessible through the hinged rear panel, which folds down to allow access, and should be changed according to the suggested maintenance schedule described in Table 5-1.

6.2.4 PNEUMATIC SENSORS

There are two pneumatic sensors: one each to measure sample pressure and flow.

6.2.4.1 SAMPLE PRESSURE SENSOR

A pressure sensor plumbed to the outlet of the sample chamber is used to measure sample pressure. The output of the sensor is used to compensate the concentration measurement for changes in air pressure.

6.2.4.2 SAMPLE FLOW SENSOR

A flow meter is used to measure the sample flow through the analyzer. The sensor is located on the pump controller PCA.

6.3 ELECTRONIC OPERATION

The electronic platform is based on a Controller Area Network (CAN) bus modular system. CAN is the central networking system that enables communication among all the parts and facilitates centralized diagnoses of errors, as well as configuration of all the parts. CAN bus technology allows for a uniform cable architecture with interchangeable 6-pin connectors configured for power (5 V and 24 V) and communications (CAN high and CAN low serial lines).

The Mainboard is the main hub, which not only contains the Central Processing Unit (CPU) that communicates with other modules, but also directs power and communication distribution. The Mainboard includes an altitude sensor, a temperature sensor, and the Supervisory Chip.

The Supervisory Chip monitors power and the sensors, and when the front panel Soft Power switch is pressed (see Power Switches, Section 6.3.2), the Supervisory Chip directs the soft power down of the internal components, to safely shut down processes and close connections to prevent data corruption.

6.3.1 MODULES

Each module consists of its own board controlled by a microprocessor that receives messages from and sends information to the Mainboard on the CAN network. Depending on the signal line, CAN Low or CAN High, the modules can determine whether a message is intended for them and what the priority is, and then act on the applicable



messages. These are called “Smart Modules,” which conduct local operations, such as activating valves or controlling manifold temperature. There is also the Sensor Module, which is comprised of the gas sensor and its operational components, as well as the data acquisition (DAQ) board with logic device, microcontroller and LED driver mounted on it. The Sensor Module calculates gas concentrations and may command the Smart Modules.

6.3.2 POWER SWITCHES

The front panel Soft Power switch is used to prevent data loss. When the instrument is initially powered on, the Supervisory Chip spins up the internal computer components and places them in operational mode (indicated by LED’s solid-lit state). However, before powering off the instrument, pressing and momentarily holding the solid-lit Soft Power switch tells the Supervisory Chip to put the internal computer components through a soft-shutdown process (indicated by LED’s blinking state).

The rear panel Hard Power switch is used to turn on or off the instrument; however, before turning off the instrument, the Soft Power switch must be used first as described above. If there is an unexpected loss of source power while the instrument is running, it will power up in the ON state when source power is restored.

6.4 SOFTWARE OPERATION

The instrument’s software developed by Teledyne API interprets user commands via the various interfaces, performs procedures and tasks, stores data in the CPU’s various memory devices and calculates the concentration of the sample gas.

6.4.1 ADAPTIVE FILTER

The Model N400 software processes sample gas measurement and reference data through an adaptive filter built into the software. Unlike other analyzers that average the output signal over a fixed time period, the Model N400 averages over a set number of samples, where a new sample is calculated approximately every 3 seconds - this is a technique is known as boxcar averaging. During operation, the software automatically switches between two different length filters, short and long, based on the conditions at hand.

During conditions of constant or nearly constant concentration, the software, by default, computes an average of the last 32 samples (long), or approximately 96 seconds. This provides the calculation portion of the software with smooth, stable readings. If a rapid change in concentration is detected, the filter length is changed to average the last 6 samples (short), approximately 18 seconds of data, to allow the analyzer to respond more quickly. If necessary, these boxcar lengths can be changed between 1 and 1000 samples but with corresponding tradeoffs in rise time and signal-to-noise ratio (contact Technical Support for more information).

Two conditions must be simultaneously met to switch to the short filter. First, the instantaneous concentration must exceed the average in the long filter by a fixed amount. Second, the instantaneous concentration must exceed the average in the long filter by a portion, or percentage, of the average in the long filter.



6.4.2 CALIBRATION - SLOPE AND OFFSET

Calibration of the analyzer is performed exclusively in software.

During instrument calibration (see Section 4) the user enters expected values for zero and span via the front panel controls, and commands the instrument to make readings of calibrated sample gases for both levels. The readings taken are adjusted, linearized, and compared to the expected values. With this information, the software computes values for instrument slope and offset and stores these values in memory for use in calculating the O₃ concentration of the sample gas.

The instrument slope and offset values recorded during the last calibration are viewable in the Dashboard (Setup>Dashboard to configure).



MODBUS REGISTERS

ADDR	TAG	DESCRIPTION
Discrete Inputs		
0	SYS_WARN_O3_GEN_REF	O3_GEN_REF_WARNING
1	LAMP_IZS_BLOCK_CONTROL_WARN	O3_GEN_LAMP_INT_WARNING
2	LAMP_IZS_BLOCK_TEMP_WARN	GEN_LAMP_TEMP_WARNING
3	ASF_PHOTO_REFERENCE_WARNING	PHOTO_REF_WARNING
4	SYS_WARN_PHOTO_REFERENCE	PHOTO_REF_WARNING
5	SYS_WARN_PHOTO_LAMP_STABILITY	Photometer lamp stability outside limits
6	PHOTO_LAMP_TEMP_WARN	Photometer lamp temperature outside limits
7	SYS_WARN_BOX_TEMP	Chassis temperature outside limits
8	SYS_WARN_SAMPLE_TEMP	Sample temperature outside limits
9	SYS_WARN_SAMPLE_FLOW	Sample flow outside limits
10	SYS_WARN_SAMPLE_PRESSURE	Sample pressure outside limits
11	SYS_WARN_RESET	CPU has rebooted
12	SYS_WARN_SUPERVISOR_COM_WARNING	Supervisor communication warning when module watchdog timer has expired
13	SYS_WARN_PHOTOMETER_COM_WARNING	Photometer module watchdog expired
14	PHOTO_LAMP_CONTROL_WARN	Photometer Lamp control module watchdog expired
15	SYS_WARN_PUMP_CONTROL_COM_WARNING	Pump Control module watchdog expired
16	SYS_WARN_ANALOG_OUTPUT_COM_WARNING	Analog Outputs module watchdog expired
17	SYS_WARN_DIGITAL_IO_COM_WARNING	Digital I/O module watchdog expired
18	SYS_WARN_LAMP_IZS_COM_WARNING	IZS Lamp module watchdog expired
19	ASF_INVALID_CONCENTRATION_WARNING	Concentration reading not valid
20	SF_ZERO_CALIBRATION_MODE	Indicates whether Zero Calibration is active
21	SF_SPAN_CALIBRATION_MODE	Indicates whether Span Calibration is active
22	SYS_WARN_AO_OUTPUT4_CAL	ANALOG_OUPUT_CAL4
23	SF_MULTIPOINT_CALIBRATION_MODE	Indicates whether Multipoint Calibration Mode is enabled
24	SYS_OK_WARN	Denotes whether fault is present in system
25	SYS_WARN_CONC_ALARM1	Concentration Alarm 1 active
26	SYS_WARN_CONC_ALARM2	Concentration Alarm 2 active
27	SYS_WARN_ACAL1_CAL_FAIL	Auto-Cal Sequence 1 failed
28	SYS_WARN_ACAL2_CAL_FAIL	Auto-Cal Sequence 2 failed
29	SYS_WARN_ACAL3_CAL_FAIL	Auto-Cal Sequence 3 failed
30	SYS_WARN_TIME_NOT_SYNCED	time-synchronization warning
31	SYS_WARN_Z-S_VALVE_COM_WARNING	ZS_VALVE_COM_WARNING
32	SYS_WARN_AO_OUTPUT1_CAL	ANALOG_OUPUT_CAL1
33	SYS_WARN_AO_OUTPUT2_CAL	ANALOG_OUPUT_CAL2
34	SYS_WARN_AO_OUTPUT3_CAL	ANALOG_OUPUT_CAL3
35	SYS_WARN_AO_OUTPUT4_CAL	ANALOG_OUPUT_CAL4
36	SYS_WARN_AO_OUTPUT5_CAL	ANALOG_OUPUT_CAL5
37	SYS_WARN_AO_OUTPUT6_CAL	ANALOG_OUPUT_CAL6
38	SYS_WARN_AO_OUTPUT7_CAL	ANALOG_OUPUT_CAL7
39	WARM_UP_COMPLETE	warm-up complete
Coils		
0	DO_RELAY1_SETPT	Control relay 36
1	DO_RELAY2_SETPT	Control relay 37
2	DO_RELAY3_SETPT	Control relay 38



ADDR	TAG	DESCRIPTION
3	DO_RELAY4_SETPT	Control relay 39
4	ASF_MAINTENANCE_MODE_SOFTWARE	Control Maintenance mode
20	MB_ZERO_CAL_RANGE1	Enable/disable external zero cal
21	MB_SPAN_CAL_RANGE1	Enable/disable external low span cal
Input Registers		
0	AI_PHOTO_MEASURE	Photometer Detector Measure Reading in mV
2	AI_PHOTO_REFERENCE	Photometer Detector Reference Reading in mV
4	PHOTO_LAMP_STABILITY	Photometer lamp stability
6	O3_SLOPE1	Slope for range 1
10	O3_OFFSET1	Offset for range 1 in PPB
14	O3_PRE_CALC_CONC_1	O3 for range 1 pre zero span calibration
18	O3_CONC	O3 conc for range 1 in PPB
22	O3_STABILITY	Concentration stability in PPB
24	AI_LAMP_IZS_O3_GEN_REF_DETECTOR	Ozone generator reference detector reading in mV
26	AO_LAMP_IZS_O3_GEN_DRIVE	Ozone generator lamp drive in mV
28	AI_LAMP_IZS_BLOCK_TEMP	Ozone generator lamp temperature in degree C
34	AI_PHOTO_LAMP_TEMP	Photo Lamp temperature in degree C
36	AI_PHOTO_LAMP_DUTY_CYCLE	Photo Lamp temperature control duty cycle
38	AI_SAMPLE_TEMP_C	Sample temperature in degree C
40	AI_PUMP_FLOW	Sample pump flow in CC/M
42	AI_PHOTO_PRESSURE_UNITS	Sample pressure in in.Hg-A
44	AI_BOX_TEMP	Box temperature in degree C
208	SV_SERIAL_NUMBER	Serial Number
Holding Registers		
0	O3_TARGET_ZERO_CONC_1	Target zero1
2	O3_TARGET_SPAN_CONC_1	Target span1



GLOSSARY

Note: Some terms in this glossary may not occur elsewhere in this manual.

TERM	DESCRIPTION/DEFINITION
10Base-T	an Ethernet standard that uses twisted (“T”) pairs of copper wires to transmit at 10 megabits per second (Mbps)
100Base-T	same as 10BaseT except ten times faster (100 Mbps)
APICOM	name of a remote control program offered by Teledyne-API to its customers
ASSY	<i>Assembly</i>
CAS	<i>Code-Activated Switch</i>
CD	<i>Corona Discharge</i> , a frequently luminous discharge, at the surface of a conductor or between two conductors of the same transmission line, accompanied by ionization of the surrounding atmosphere and often by a power loss
CE	<i>Converter Efficiency</i> , the percentage of light energy that is actually converted into electricity
CEM	<i>Continuous Emission Monitoring</i>
Chemical formulas that may be included in this document:	
CO ₂	carbon dioxide
C ₃ H ₈	propane
CH ₄	methane
H ₂ O	water vapor
HC	general abbreviation for hydrocarbon
HNO ₃	nitric acid
H ₂ S	hydrogen sulfide
NO	nitric oxide
NO ₂	nitrogen dioxide
NO _x	nitrogen oxides, here defined as the sum of NO and NO ₂
NO _y	nitrogen oxides, often called odd nitrogen: the sum of NO _x plus other compounds such as HNO ₃ (definitions vary widely and may include nitrate (NO ₃), PAN, N ₂ O and other compounds as well)
NH ₃	ammonia
O ₂	molecular oxygen
O ₃	ozone
SO ₂	sulfur dioxide
cm ³	metric abbreviation for <i>cubic centimeter</i> (replaces the obsolete abbreviation “cc”)
CPU	<i>Central Processing Unit</i>
DAC	<i>Digital-to-Analog Converter</i>
DAS	<i>Data Acquisition System</i>
DCE	<i>Data Communication Equipment</i>
DFU	<i>Dry Filter Unit</i>
DHCP	<i>Dynamic Host Configuration Protocol</i> . A protocol used by LAN or Internet servers to automatically set up the interface protocols between themselves and any other addressable device connected to the network
DIAG	<i>Diagnostics</i> , the diagnostic settings of the analyzer.



TERM	DESCRIPTION/DEFINITION
DOM	<i>Disk On Module</i> , a 44-pin IDE flash drive with up to 128MB storage capacity for instrument's firmware, configuration settings and data
DOS	<i>Disk Operating System</i>
DRAM	<i>Dynamic Random Access Memory</i>
DR-DOS	<i>Digital Research DOS</i>
DTE	<i>Data Terminal Equipment</i>
EEPROM	<i>Electrically Erasable Programmable Read-Only Memory</i> also referred to as a FLASH chip or drive
ESD	<i>Electro-Static Discharge</i>
ETEST	<i>Electrical Test</i>
Ethernet	a standardized (IEEE 802.3) computer networking technology for local area networks (LANs), facilitating communication and sharing resources
FEP	<i>Fluorinated Ethylene Propylene</i> polymer, one of the polymers that Du Pont markets as <i>Teflon</i> [®]
Flash	non-volatile, solid-state memory
FPI	<i>Fabry-Perot Interface</i> : a special light filter typically made of a transparent plate with two reflecting surfaces or two parallel, highly reflective mirrors
GFC	<i>Gas Filter Correlation</i>
I ² C bus	a clocked, bi-directional, serial bus for communication between individual analyzer components
IC	<i>Integrated Circuit</i> , a modern, semi-conductor circuit that can contain many basic components such as resistors, transistors, capacitors etc in a miniaturized package used in electronic assemblies
IP	<i>Internet Protocol</i>
IZS	<i>Internal Zero Span</i>
LAN	<i>Local Area Network</i>
LCD	<i>Liquid Crystal Display</i>
LED	<i>Light Emitting Diode</i>
LPM	<i>Liters Per Minute</i>
MFC	<i>Mass Flow Controller</i>
M/R	<i>Measure/Reference</i>
MOLAR MASS	the mass, expressed in grams, of 1 mole of a specific substance. Conversely, one mole is the amount of the substance needed for the molar mass to be the same number in grams as the atomic mass of that substance. EXAMPLE: The atomic weight of Carbon is 12 therefore the molar mass of Carbon is 12 grams. Conversely, one mole of carbon equals the amount of carbon atoms that weighs 12 grams. Atomic weights can be found on any Periodic Table of Elements.
NDIR	<i>Non-Dispersive Infrared</i>
NIST-SRM	<i>National Institute of Standards and Technology - Standard Reference Material</i>
PC	<i>Personal Computer</i>
PCA	<i>Printed Circuit Assembly</i> , the PCB with electronic components, ready to use
PC/AT	<i>Personal Computer / Advanced Technology</i>
PCB	<i>Printed Circuit Board</i> , the bare board without electronic component
PFA	<i>Perfluoroalkoxy</i> , an inert polymer; one of the polymers that <i>Du Pont</i> markets as <i>Teflon</i> [®]



TERM	DESCRIPTION/DEFINITION
PLC	<i>Programmable Logic Controller</i> , a device that is used to control instruments based on a logic level signal coming from the analyzer
PLD	<i>Programmable Logic Device</i>
PLL	<i>Phase Lock Loop</i>
PMT	<i>Photo Multiplier Tube</i> , a vacuum tube of electrodes that multiply electrons collected and charged to create a detectable current signal
P/N (or PN)	<i>Part Number</i>
PSD	<i>Prevention of Significant Deterioration</i>
PTFE	<i>Polytetrafluoroethylene</i> , a very inert polymer material used to handle gases that may react on other surfaces; one of the polymers that <i>Du Pont</i> markets as <i>Teflon</i> [®]
PVC	<i>Poly Vinyl Chloride</i> , a polymer used for downstream tubing
Rdg	Reading
RS-232	specification and standard describing a serial communication method between DTE (Data Terminal Equipment) and DCE (Data Circuit-terminating Equipment) devices, using a maximum cable-length of 50 feet
RS-485	specification and standard describing a binary serial communication method among multiple devices at a data rate faster than RS-232 with a much longer distance between the host and the furthest device
SAROAD	<i>Storage and Retrieval of Aerometric Data</i>
SLAMS	<i>State and Local Air Monitoring Network Plan</i>
SLPM	<i>Standard Liters Per Minute</i> of a gas at standard temperature and pressure
STP	<i>Standard Temperature and Pressure</i>
TCP/IP	<i>Transfer Control Protocol / Internet Protocol</i> , the standard communications protocol for Ethernet devices
TEC	<i>Thermal Electric Cooler</i>
TPC	<i>Temperature/Pressure Compensation</i>
USB	<i>Universal Serial Bus</i> : a standard connection method to establish communication between peripheral devices and a host controller, such as a mouse and/or keyboard and a personal computer or laptop
VARS	<i>Variables</i> , the variable settings of the instrument
V-F	<i>Voltage-to-Frequency</i>
Z/S	<i>Zero / Span</i>



A

AC Power, 15
Analog Outputs, 15, 24, 25
 Test Channel, 24
APICOM
 and Failure Prediction, 82
AutoCal, 36, 37, 74, 75, 111

B

Beer-Lambert Equation, 116
BENCH TEMP, 96
BOX TEMP, 94, 96, 102
BOX TEMP WARNING, 94
brass, 70

C

Calibration Gasses
 Span Gas, 29, 70, 71, 111
 Zero Air, 29, 70, 80, 110
Control Inputs, 24, 25, 36, 37
CPU, 96, 115
Critical Flow Orifice, 118

D

DAS System, 72, 82, 94, 113
 Parameters
 STABIL, 94
data acquisition. See DAS System
Default Settings
 Hessen Protocol, 67
Dilution Ratio
 Set Up, 71

E

Electrical Connections
 AC Power, 23
 Control Inputs, 25
 Ethernet, 69
 Serial/COMM Ports, 26
Electro-Static Discharge, 17
ENTR Button, 105
Environmental Protection Agency(EPA)
 Calibration, 28, 30
Ethernet, 69
Exhaust Gas, 21
Exhaust Gas Outlet, 21, 29, 32, 33, 34

EXIT Button, 105

F

FEP, 27, 70

G

Gas Filter Correlation, 116
Gas Inlets, 94
 Sample, 21
 Span, 21
 Zero Air, 21
Gas Outlets, 31, 34
 Exhaust, 21, 29, 32, 33

H

Hessen Protocol, 67
 Default Settings, 67

I

Infrared Radiation (IR), 111
Internal Pneumatics
 Basic Configuration, 35
 Zero/Span Valves, 37
Internal Pump, 89, 100, 101, 118
Internal Zero Air (IZS), 21, 28, 100
Internal Zero/Span Option (IZS), 16
 Generator, 16, 92, 96, 110
 Maintenance, 80, 88, 90
 O₃ Scrubber, 80, 116
 Span Gas for, 28
 Specifications, 16
 Troubleshooting, 82, 95, 102
 Valve States, 37
IZS
 Reference Feedback Option, 16

L

LAMP STABIL WARN, 94

M

Measure Reference Ratio, 116
Measurement / Reference Cycle, 116
Menu Buttons
 ENTR, 105
 EXIT, 105
Metal Wool Scrubber
 Troubleshooting, 102



MR Ratio, 82

O

O3 GEN TEMP WARN, 95
O₃ Generator IZS, 92, 96, 110
O₃ MEAS, 95
O₃ REF, 105
O₃ Scrubber, 80, 116
OFFSET, 82, 96
Ozone, 106

P

Particulate Filter, 80, 82, 86, 94, 119
PHOTO REF WARNING, 95
PHOTO TEMP WARNING, 94
Photometer
 Absorption Tube, 80
 UV Absorption Path, 115, 116
 UV detector, 94
PHT DRIVE, 82, 96
Pneumatic Set Up
 Basic
 Bottled Gas, 29
 Basic Model
 Gas Dilution Calibrator, 35
 Calibration Gasses, 28
 Zero/Span/Shutoff Valves, 33
PRES, 82, 89, 94, 95
PTEF, 29, 32
PTFE, 27, 70, 87
Pump
 Sample, 94

R

RANGE, 95
Reference Feedback Option (IZS), 16
Reporting Range
 Upper Span Limit, 71
RS-232, 66, 104

S

SAFETY MESSAGES
 Electric Shock, 23
 GENERAL, 17, 22, 23, 27
SAMPLE FL, 95
Sample Flow Sensor, 94, 119
SAMPLE FLOW WARN, 94
Sample Gas Line, 29, 32, 33, 34
Sample Inlet, 21

Sample Pressure Sensor, 94, 119
SAMPLE TEMP, 96
SAMPLE TEMP WARN, 94
Sample Temperature Sensor, 94
Sensors
 Sample Flow, 94
 Sample Pressure, 94
 Sample Temperature, 94
 Thermistors
 Sample Temperature, 94
Serial I/O Ports, 15
SLOPE, 82, 96
Span Gas, 21, 29, 70, 71, 89, 96, 100, 101,
 102, 111
Span Inlet, 21
Specifications, 15, 16
STABIL, 82, 94, 95
SYSTEM RESET, 95

T

Teledyne Contact Information
 Email Address, 112
 Fax, 112
 Phone, 112
 Technical Assistance, 112
 Website, 112
Test Channel, 24
Test Functions, 80
 BENCH TEMP, 96
 BOX TEMP, 94, 96, 102
 MR Ratio, 82
 O₃ MEAS, 95
 O₃ REF, 105
 OFFSET, 82, 96
 PHT DRIVE, 82, 96
 PRES, 82, 89, 94, 95
 RANGE, 95
 SAMPLE FL, 95
 SAMPLE TEMP, 96
 SLOPE, 82, 96
 STABIL, 82, 94, 95
 TIME, 75
Theory of Operation
 Beer-Lambert Equation, 116
TIME, 75

U

Ultraviolet Light, 14, 115, 116, 117
Units of Measurement, 72
UV Absorption Path, 115, 116
UV detector, 94
UV Source
 Photometer



Replacement, 91
Troubleshooting, 95, 102

V

Valve Options, 21

Internal Zero/Span Option (IZS), 16

Generator, 92, 96, 110

Maintenance, 80, 88

O₃ Scrubber, 80, 116

Span Gas for, 28

Specifications, 16

Troubleshooting, 82, 95, 102

Valve States, 37

Zero/Span

Valve States, 36

with Remote Contact Closure, 74

Zero/Span Valves

Internal Pneumatics, 37

Zero/Span/Shutoff Valves

Pneumatic Set Up, 33

Ventilation Clearance, 18

Venting

Exhaust Line, 29, 32

W

Warm-up Period, 39

Warning Messages

BOX TEMP WARNING, 94

LAMP STABIL WARN, 94

O₃ GEN TEMP WARN, 95

PHOTO REF WARNING, 95

PHOTO TEMP WARNING, 94

SAMPLE FLOW WARN, 94

SAMPLE TEMP WARN, 94

SYSTEM RESET, 95

Warnings, 39

Z

Zero Air, 28, 29, 70, 80, 96, 100, 101, 110, 111

Zero Ar Inlet, 21

Zero/Span Valves

Internal Pneumatics, 37

Zero/Span/Shutoff Valves

Pneumatic Set Up, 33

