



User Manual
Models N300, N300M
CO Analyzers



© Teledyne API (TAPI)
9970 Carroll Canyon Road
San Diego, California
92131-1106
USA

Toll-free Phone: +1 800-324-5190
Phone: +1 858-657-9800
Fax: +1 858-657-9816
Email: api-sales@teledyne.com
Website: <http://www.teledyne-api.com>



N300, N300M

NOTICE OF COPYRIGHT

© 2022-24 Teledyne API (TAPI). All rights reserved.

TRADEMARKS

All trademarks, registered trademarks, brand names or product names appearing in this document are the property of their respective owners and are used herein for identification purposes only.

SAFETY MESSAGES

Important safety messages are provided throughout this manual for the purpose of avoiding personal injury or instrument damage. Please read these messages carefully. Each safety message is associated with a safety alert symbol and is placed throughout this manual; the safety symbols are also located inside the instrument. It is imperative that you pay close attention to these messages, the descriptions of which are as follows:



WARNING: Electrical Shock Hazard



HAZARD: Strong oxidizer



GENERAL WARNING/CAUTION: Read the accompanying message for specific information.



CAUTION: Hot Surface Warning



Do Not Touch: Touching some parts of the instrument without protection or proper tools could result in damage to the part(s) and/or the instrument.



Technician Symbol: All operations marked with this symbol are to be performed by qualified maintenance personnel only.



N300, N300M

CAUTION

This product should only be installed, commissioned, and used strictly for the purpose and in the manner described in this manual. If you improperly install, commission, or use this instrument in any manner other than as instructed in this manual or by our Technical Support team, unpredictable behavior could ensue with possible hazardous consequences.

Such risks, whether during installation and commission or caused by improper installation/commissioning/use, and their possible hazardous outcomes include but are not limited to:



RISK	HAZARD
Liquid or dust/debris ingress	Electrical shock hazard
Improper or worn power cable	Electrical shock or fire hazard
Excessive pressure from improper gas bottle connections	Explosion and projectile hazard
Sampling combustible gas(es)	Explosion and fire hazard
Improper lift & carry techniques	Personal injury

Note that the safety of a system that may incorporate this product is the end user's responsibility.

For Technical Assistance regarding the use and maintenance of this instrument or any other Teledyne API product, contact Teledyne API's Technical Support Department:

Telephone: +1 800-324-5190 (toll free) or +1 858-657-9800

Email: api-techsupport@teledyne.com

or access any of the service options on our website at <http://www.teledyne-api.com/>

CONSIGNES DE SÉCURITÉ

Des consignes de sécurité importantes sont fournies tout au long du présent manuel dans le but d'éviter des blessures corporelles ou d'endommager les instruments. Veuillez lire attentivement ces consignes. Chaque consigne de sécurité est représentée par un pictogramme d'alerte de sécurité; ces pictogrammes se retrouvent dans ce manuel et à l'intérieur des instruments. Les symboles correspondent aux consignes suivantes :



AVERTISSEMENT : Risque de choc électrique



DANGER : Oxydant puissant



AVERTISSEMENT GÉNÉRAL / MISE EN GARDE : Lire la consigne complémentaire pour des renseignements spécifiques



MISE EN GARDE : Surface chaude



Ne pas toucher : Toucher à certaines parties de l'instrument sans protection ou sans les outils appropriés pourrait entraîner des dommages aux pièces ou à l'instrument.



Pictogramme « technicien » : Toutes les opérations portant ce symbole doivent être effectuées uniquement par du personnel de maintenance qualifié.

MISE EN GARDE

Ce produit ne doit être installé, mis en service et utilisé qu'aux fins et de la manière décrites dans le présent manuel. Si vous installez, mettez en service ou utilisez cet instrument de manière incorrecte autre que celle indiquée dans ce manuel ou sous la direction de notre équipe de soutien technique, un comportement imprévisible pourrait entraîner des conséquences potentiellement dangereuses.

Ce qui suit est une liste, non exhaustive, des risques et résultats dangereux possibles associés avec une mauvaise utilisation, une mise en service incorrecte, ou causés mauvaise commission.



RISQUE	DANGER
Pénétration de liquide ou de poussière/débris	Risque de choc électrique
Câble d'alimentation incorrect, endommagés ou usé	Choc électrique ou risque d'incendie
Pression excessive due à des connexions de bouteilles de gaz incorrectes	Risque d'explosion et d'émission de projectile
Échantillonnage de gaz combustibles	Risque d'explosion et d'incendie
Techniques de manutention, soulèvement et de transport inappropriées	Blessure corporelle

Notez que la sécurité d'un système qui peut incorporer ce produit est la responsabilité de l'utilisateur final.

WARRANTY

WARRANTY POLICY (02024J)

Teledyne API (TAPI), a business unit of Teledyne Instruments, Inc., provides that:

Prior to shipment, TAPI equipment is thoroughly inspected and tested. Should equipment failure occur, TAPI assures its customers that prompt service and support will be available. (For the instrument-specific warranty period, please refer to the “Limited Warranty” Section in the Terms and Conditions of Sale on our website at: <http://www.teledyne-api.com>.)

COVERAGE

After the warranty period and throughout the equipment lifetime, TAPI stands ready to provide on-site or in-plant service at reasonable rates similar to those of other manufacturers in the industry. All maintenance and the first level of field troubleshooting are to be performed by the customer.

NON-TAPI MANUFACTURED EQUIPMENT

Equipment provided but not manufactured by TAPI is warranted and will be repaired to the extent and according to the current terms and conditions of the respective equipment manufacturer’s warranty.

PRODUCT RETURN

All units or components returned to Teledyne API should be properly packed for handling and returned freight prepaid to the nearest designated Service Center. After the repair, the equipment will be returned, freight prepaid.

Please review the complete Terms and Conditions of Sale on our website.

CAUTION – Avoid Warranty Invalidation



Failure to comply with proper anti-Electro-Static Discharge (ESD) handling and packing instructions and Return Merchandise Authorization (RMA) procedures when returning parts for repair or calibration may void your warranty. For anti-ESD handling and packing instructions please refer to the manual, Fundamentals of ESD, PN 04786, in its “Packing Components for Return to Teledyne API’s Customer Service” section. The manual can be downloaded from our website at <http://www.teledyne-api.com>. RMA procedures can also be found on our website.



ABOUT THIS MANUAL

NOTE

We recommend that all users read this manual in its entirety before operating the instrument.

CONVENTIONS USED

In addition to the safety symbols as presented in the *Safety Messages* page, this manual provides *special notices* related to the careful and effective use of the instrument and related, pertinent information.

ATTENTION

COULD DAMAGE INSTRUMENT AND VOID WARRANTY

This special notice provides information to avoid damage to your instrument and possibly invalidate the warranty.

IMPORTANT

IMPACT ON READINGS OR DATA

Provides information about that which could either affect accuracy of instrument readings or cause loss of data.

NOTE

Provides information pertinent to the proper care, operation or maintenance of the instrument or its parts.

TABLE OF CONTENTS

1. Introduction, Specifications, Approvals, & Compliance.....	15
1.1 Specifications.....	16
1.2 EPA Designation	18
1.3 Compliance and Certifications.....	18
2. Getting Started.....	19
2.1 Unpacking.....	19
2.1.1 Ventilation Clearance	20
2.2 Instrument Layout.....	21
2.2.1 Front Panel.....	21
2.2.2 Rear panel.....	22
2.2.3 Internal Chassis	23
2.3 Connections and Startup	26
2.3.1 Electrical Connections.....	26
2.3.1.1 Connecting Power	26
2.3.1.2 Connecting Analog Outputs Option.....	27
2.3.1.3 Connecting the Digital I/O Expansion Board Option	28
2.3.1.4 Connecting the Communication Interfaces	29
2.3.2 Pneumatic Connections	30
2.3.2.1 Critical Tubing, Pressure, Venting and Exhaust Requirements	32
2.3.2.2 Pneumatic Connections: Basic Configuration	33
2.3.2.3 Pneumatic Connections: Ambient Zero/Ambient Span Option	34
2.3.2.4 Pneumatic Connections: Ambient Zero/Pressurized Span Option	36
2.3.2.5 Pneumatic Connections: Zero Scrubber/Pressurized Span Option	38
2.3.2.6 Pneumatic Connections: Zero Scrubber/Ambient Span Option (N300).....	39
2.3.3 Pneumatic Flow Diagrams	41
2.3.3.1 Pneumatic Flow: Basic Configuration.....	41
2.3.3.2 Pneumatic Flow: N300 Ambient Zero/Ambient Span Valve Option	42
2.3.3.3 Pneumatic Flow: N300 Ambient Zero/Pressurized Span Option	43
2.3.4 Startup, Functional Checks, and Initial Calibration	44
2.3.4.1 Power Status	44
2.3.4.2 Startup	45
2.3.4.3 Alerts: Warnings and Other Messages.....	46
2.3.4.4 Functional Checks	46
2.3.4.5 Initial Calibration	47
2.4 Menu Overview.....	48
2.4.1 Home Page	49
2.4.2 Dashboard.....	51
2.4.3 Alerts	53
2.4.4 Calibration	54
2.4.5 Utilities.....	55
2.4.6 Setup	55
2.5 Setup Menu: Features/Functions Configuration.....	56
2.5.1 Setup>Data Logging (Data Acquisition System, DAS)	56
2.5.1.1 Configuring Trigger Types: Periodic.....	59
2.5.1.2 Configuring Trigger Types: Conditional.....	59
2.5.1.3 Downloading DAS (Data Acquisition System) Data	60
2.5.2 Setup>Events.....	60
2.5.2.1 Editing or Deleting Events	62
2.5.2.2 Using Events as Triggers for Data Logging.....	62
2.5.3 Setup>Dashboard	63
2.5.4 Setup>AutoCal (with Valve Option)	63
2.5.5 Setup>Vars	63



N300, N300M

2.5.6	Setup>Homescreen	65
2.5.7	Setup>Digital Outputs (Option)	66
2.5.8	Setup>Analog Outputs (Option)	67
2.5.8.1	Manual Calibration Adjustment of Voltage Range Analog Outputs	70
2.5.8.2	Manual Calibration Adjustment of Current Range Analog Outputs	70
2.5.9	Setup>Instrument	71
2.5.10	Setup>Comm (Communications)	72
2.5.10.1	COM2	72
2.5.10.2	TCP Port2	73
2.5.10.3	Network Settings	73
2.5.10.4	Hessen	73
2.6	Transferring Configuration to Other Instruments	74
3	Communications and Remote Operation	75
3.1	Serial Communication	75
3.1.1	MODBUS	75
3.1.2	Hessen	76
3.1.3	REST	77
3.2	Ethernet	78
3.3	NumaView™ Remote	78
4	Calibration	79
4.1	Important Precalibration Information	79
4.1.1	Calibration Requirements	79
4.1.2	Zero Air	79
4.1.3	Calibration (Span) Gas	80
4.1.4	Interferents	80
4.1.5	Dilution Ratio Option Software Set Up	80
4.1.6	Second Gas Sensor Options Calibration	80
4.1.7	Data Recording Devices	81
4.2	Calibration Procedures	81
4.2.1	Calibration and Check Procedures for Basic Configuration	81
4.2.1.1	Zero Calibration Check and Actual Calibration	82
4.2.1.2	Span Calibration Check and Actual Calibration	82
4.2.2	Calibration and Check Procedures with Valve Option Installed	83
4.2.2.1	Use of Zero/Span Valves with Digital Expansion Board Option	83
4.2.2.2	Automatic Zero/Span Cal Check (AutoCal) with Zero/Span Valve	84
4.3	Calibration Quality	85
4.4	Calibration of the Analyzer's Electronic Subsystems	85
4.4.1	Dark Calibration Test	86
4.4.2	Pressure Calibration	86
4.4.3	Flow Calibration	86
4.5	Calibration of Optional Sensors	87
4.5.1	O ₂ Sensor Calibration	87
4.5.2	CO ₂ Sensor Calibration Procedure	88
4.6	EPA Protocol Calibration	88
5	Maintenance and Service	89
5.1	Maintenance Schedule	89
5.2	Predictive Diagnostics	92
5.3	Operational Health Checks	93
5.4	Software/Firmware Updates	94
5.4.1	Remote Updates	94
5.4.2	Manual Reload/Update Procedures	94
5.5	Time Zone Changes	96
5.6	Maintenance Procedures	97
5.6.1	Replacing the 47 mm Sample Particulate Filter Option (N300)	97



N300, N300M

5.6.2	changing the Long-Life DFU Filter Option (N300)	98
5.6.3	Rebuilding the Sample Pump	98
5.6.4	Performing Leak Checks	98
5.6.4.1	Vacuum Leak Check and Pump Check	98
5.6.4.2	Pressure Leak Check	99
5.6.5	Performing a Sample Flow Check	99
5.6.6	Cleaning the Optical Bench	100
5.7	Troubleshooting	100
5.7.1	Fault Diagnosis with Alerts	101
5.7.2	Fault Diagnosis with Dashboard Functions	102
5.7.3	Using The Diagnostic Signal I/O Functions	103
5.7.4	Fault Diagnosis with LEDs	104
5.7.5	Flow Problems	105
5.7.5.1	Flow is Zero	106
5.7.5.2	Low Flow	107
5.7.5.3	High Flow	107
5.7.5.4	Flow Alert	108
5.7.5.5	Actual Flow Does Not Match Displayed Flow	108
5.7.5.6	Sample Pump	108
5.7.6	Calibration Problems	109
5.7.6.1	Miscalibrated	109
5.7.6.2	Non-Repeatable Zero and Span	109
5.7.6.3	Inability to Span – No SPAN Button	110
5.7.6.4	Inability to Zero – No ZERO Button	110
5.7.7	Other Performance Problems	110
5.7.7.1	Temperature Problems	110
5.7.7.2	Excessive Noise	111
5.7.7.3	Slow Response	111
5.7.8	Subsystem Check for Troubleshooting	112
5.7.8.1	AC Main Power	112
5.7.8.2	Touchscreen Interface	112
5.7.9	RS-232 Communications	112
5.8	Service Procedures	113
5.8.1	Replacing the Fuse	113
5.8.2	Replacing a Module	114
5.8.2.1	Connectors on Mainboard	115
5.8.2.2	Connectors on DC Pump PCA	115
5.8.2.3	Connectors on GFC Sensor PCA	116
5.8.3	Removing/Replacing the GFC Wheel	116
5.9	Frequently Asked Questions	119
5.10	Technical Assistance	121
6.	Theory of Operation	122
6.1	Measurement Method	122
6.1.1	Beer's Law	123
6.2	Measurement Fundamentals	123
6.2.1	Gas Filter Correlation	124
6.2.1.1	The GFC Wheel	124
6.2.1.2	The Measure/Reference (M/R) Ratio	125
6.2.1.3	Interference and Signal to Noise Rejection	126
6.2.1.4	Summary Interference Rejection	127
6.3	Oxygen Sensor (Option)	127
6.3.1	Paramagnetic Measurement of O ₂	127
6.3.1.1	O ₂ Sensor Operation within the Analyzer	128
6.4	Pneumatic Operation	128
6.4.1	Flow Rate Control	129



N300, N300M

6.4.1.1	Critical Flow Orifice.....	129
6.4.2	Particulate Filter	130
6.4.3	Pneumatic Sensors	130
6.4.3.1	Sample Pressure Sensor.....	130
6.4.3.2	Sample Flow Sensor	130
6.5	Electronic Operation	131
6.5.1	Modules.....	131
6.5.2	Power Switches.....	131
6.5.3	Optical Bench & GFC Wheel.....	131
6.5.3.1	Temperature Control	132
6.5.3.2	IR Source.....	132
6.5.3.3	GFC Wheel.....	133
6.5.3.4	IR Photo-Detector.....	134
6.6	Software Operation.....	134
6.6.1	Adaptive Filter for Stability	135
6.6.2	Calibration - Slope and Offset.....	135
6.6.3	Measurement Algorithm.....	135
6.6.4	Temperature and Pressure Compensation (TPC).....	135

Appendix A – MODBUS Registers

Appendix B – Interconnect Diagrams



FIGURES

Figure 2-1. Front Panel Layout.....21

Figure 2-2. Rear Panel Layout22

Figure 2-3. Internal Layout – N300.....23

Figure 2-4. Internal Layout – N300M.....24

Figure 2-5. Optical Bench Layout (shorter bench, N300M, shown).....25

Figure 2-6. Analog Outputs Connectors Panel Option.....27

Figure 2-7. Digital I/O Connector Panel Option.....28

Figure 2-8. Mainboard JP1 Location and Pin Arrangements29

Figure 2-9. Pneumatic Connections – Basic Configuration Using Bottled Span Gas.....33

Figure 2-10. Pneumatic Connections – Basic Configuration Using Gas Dilution Calibrator.....33

Figure 2-11. Pneumatic Connections – Zero/Span Option35

Figure 2-12. Pneumatic Connections – Ambient Zero/Pressurized Span Option.....36

Figure 2-13. Pneumatic Connections – Zero Scrubber/Pressurized Span Option.....38

Figure 2-14. N300 Pneumatic Connections – Zero/Span Option.....39

Figure 2-15. N300/N300M Internal Gas Flow (Basic Configuration).....41

Figure 2-16. N300 Internal Pneumatic Flow for Zero/Span Valves Option.....42

Figure 2-17. N300 Internal Pneumatic Flow for Ambient Zero/Pressurized Span Option.....43

Figure 2-18. Status Screens at Startup.....45

Figure 2-19. Home Page Example45

Figure 2-20. Viewing Active Alerts Page.....46

Figure 2-21. Sample Dashboard Page.....47

Figure 2-22. User Interface Orientation.....49

Figure 2-23. Concentration and Stability Graph (top) and Meter Graph (bottom).....50

Figure 2-24. Dashboard Page.....51

Figure 2-25. Navigating to the Active Alerts Page.....53

Figure 2-26. Active Alerts Cleared.....54

Figure 2-27. Utilities>Alerts Log of Active and Past Alerts and Events.....54

Figure 2-28. Datalog Configuration, New Log Page.....57

Figure 2-29. Datalog Configuration, Existing Log.....57

Figure 2-30. Creating a New Data Log.....58

Figure 2-31. Datalog Periodic Trigger Configuration.....59

Figure 2-32. Datalog - Conditional Trigger Configuration59

Figure 2-33. DAS Download Page60

Figure 2-34. Events List.....60

Figure 2-35. Event Configuration.....61

Figure 2-36. Configured Event Sample61

Figure 2-37. Edit or Delete an Event.....62

Figure 2-38. Dashboard Display and Configuration63

Figure 2-39. Homescreen Configuration65

Figure 2-40. Digital Outputs Setup.....66

Figure 2-41. Analog Output Configuration for Voltage Output, Example.....67

Figure 2-42. Analog Output Configuration for Current Output, Example.....68

Figure 2-43. Analog Output Calibration, Voltage or Current.....69

Figure 2-44. Setup for Checking / Calibrating DCV Analog Output Signal Levels.....70

Figure 2-45. Setup for Checking / Calibration Current Output Signal Levels.....71

Figure 2-46. Communications Configuration, Network Settings73

Figure 2-47. Configuration Transfer74

Figure 4-1. Multi-Point Calibration Page82

Figure 4-2. Zero and Span Calibration Screens.....83

Figure 4-3. Auto Cal Page.....84

Figure 4-3. O₂ Sensor Calibration Set Up87



N300, N300M

Figure 4-4. CO ₂ Sensor Calibration Set Up.....	88
Figure 5-1: Report Generation Page	93
Figure 5-2. Remote Update Page.....	94
Figure 5-3. Manual Update Page (and other utilities).....	94
Figure 5-4. Time Zone Change Requirements	96
Figure 5-5. Sample Particulate Filter's Membrane Filter Element.....	97
Figure 5-6. Mainboard	104
Figure 5-7. GFC Sensor Board LEDs.....	105
Figure 5-8. DC Pump Control Board LEDs	105
Figure 5-9. HD non-PID Controlled Pump.....	106
Figure 5-10. STD PID Controlled Pump	106
Figure 5-11. Fuse Access.....	114
Figure 5-12. Mainboard Connectors.....	115
Figure 5-13. DC Pump Control Board Connectors.....	115
Figure 5-14. GFC Sensor Board Connectors	116
Figure 5-15. Opening the GFC Wheel Housing	117
Figure 5-16. Removing the Opto-Pickup Assembly	118
Figure 5-17. Removing the GFC Wheel Housing.....	118
Figure 5-18. Removing the GFC Wheel	119
Figure 6-1. IR Beam Path.....	124
Figure 6-2. GFC Wheel	124
Figure 6-3. Measurement Fundamentals with GFC Wheel.....	125
Figure 6-4. Effect of CO in the Sample on IR Measure & IR Reference	126
Figure 6-5. Effects of Interfering Gas on IR Measure and IR Reference	126
Figure 6-6. Chopped IR Signal	127
Figure 6-7. Oxygen Sensor - Principle of Operation	128
Figure 6-8. Flow Control Assembly & Critical Flow Orifice.....	130
Figure 6-9. GFC Light Mask	133
Figure 6-10. Segment Sensor and M/R Sensor Output	134



TABLES

Table 1-1. N300/N300M Basic Unit Specifications.....	16
Table 1-2. O ₂ Sensor Option Specifications	17
Table 1-3. CO ₂ Sensor Option Specifications	17
Table 2-1. Ventilation Clearance	20
Table 2-2. Rear Panel Description	22
Table 2-3. Analog Output Pin Assignments	27
Table 2-4. Digital I/O Pin Assignments.....	28
Table 2-5. JP1 Configurations for Serial Communication	30
Table 2-6. Zero/Span Valve Option Operating States.....	42
Table 2-7. Operating States for Ambient Zero/Pressurized Span Option	43
Table 2-8. Menu Overview	48
Table 2-9. Common Dashboard Parameters	51
Table 2-10. Utilities Submenu Descriptions	55
Table 2-11. List of Variables with Descriptions	64
Table 3-1. Teledyne API's Hessen Protocol Response Modes.....	76
Table 3-2. Hessen List Configuration Summary.....	77
Table 3-3. REST Resource Descriptions	77
Table 3-4. Ethernet Status Indicators	78
Table 4-1. Auto Cal Programming Sequence Execution.....	85
Table 4-2. Calibration Data Quality Evaluation	85
Table 5-1. N300/N300M Maintenance Schedule	90
Table 5-2. N300/N300M Functions Record.....	91
Table 5-3. Predictive Uses for Dashboard Functions.....	92
Table 5-4. Alerts - Indicated Failures.....	101
Table 5-5. Dashboard Functions - Indicated Failures	102
Table 6-1. Absorption Path Length.....	123



1. INTRODUCTION, SPECIFICATIONS, APPROVALS, & COMPLIANCE

Teledyne API's Model N300 and Model N300M are Gas Filter Correlation Carbon Monoxide Analyzers. These microprocessor-controlled analyzers are used to determine the concentration of carbon monoxide (CO) in a sample gas drawn through the instrument. The analysis method is based on the Beer-Lambert law, an empirical relationship that relates the absorption of light to the properties of the material through which the light is traveling over a defined distance. In this case the light is infrared radiation (IR) traveling through a sample chamber filled with gas bearing a varying concentration of CO.

The N300 and the N300M use Gas Filter Correlation (GFC) to overcome the interfering effects of various other gases (such as water vapor) that also absorb IR. The analyzer passes the IR beam through a spinning wheel made up of two separate chambers: one containing a high concentration of CO known as the *reference*, and the other containing a neutral gas known as the *measure*. The concentration of CO in the sample chamber is computed by taking the ratio of the instantaneous measure and reference values and then compensating the ratio for sample temperature and pressure.

Smart modules on a CAN Bus communications system manage the functions and controls of the instrument, and with the modular architecture comes fast, efficient assembly replacements that facilitate maximum operation time. Further enhancing the user experience is the touch-control interface screen for quick customization and for real-time readings not only numerically, but also graphically. Proprietary software allows configurable data acquisition capability that can be triggered conditionally or periodically, enabling operators to perform predictive diagnostics and enhanced data analysis by tracking parameter trends. Reports can be downloaded onto a USB flash drive or via the I/O ports.

1.1 SPECIFICATIONS

Table 1-1. N300/N300M Basic Unit Specifications

PARAMETER	SPECIFICATION	
	N300	N300M
Ranges	Min: 0-1 ppm Full scale Max: 0-1,000 ppm Full scale	Min: 0-5 ppm Full scale Max: 0-5,000 ppm Full scale
	(user selectable, dual-range supported)	
Measurement Units	ppb, ppm, $\mu\text{g}/\text{m}^3$, mg/m^3 (user selectable)	ppm, mg/m^3 (user selectable)
Response Time ¹	< 70 seconds to 95%	< 70 seconds to 95%
Sample Flow Rate	800 cc/min $\pm 10\%$	800 cc/min $\pm 10\%$
	(O ₂ Sensor option adds 120 cm ³ /min to total flow when installed)	
Zero Noise ¹	< 0.02 ppm RMS	< 0.1 ppm RMS
Span Noise ¹	< 0.5% of reading (RMS) above 5 ppm	< 0.5% of reading RMS above 20 ppm
Lower Detectable Limit ¹	< 0.04 ppm	< 0.2 ppm
Precision	0.5% of reading above 5 ppm	1.0% of reading
Linearity	1% of full scale	$\pm 1\%$ of full scale
Zero Drift (24 hours) ²	< 0.1 ppm	< 0.5 ppm
Span Drift (24 hours) ²	< 0.5% of reading	< 0.5% of reading
AC Power	Rating / Typical Power Consumption	Rating / Typical Power Consumption
	100 V - 240 V, 50/60 Hz, 3.0 A / 115W	100 V - 240 V, 50/60 Hz, 3.0 A / <150 W
Power Entry Module Fuse	5.0 A, 250 V AC, 5 mm x 20 mm, SLO-BLO	
Communications		
Standard I/O	1 Ethernet: TCP/IP 1 RS-232 (300 – 115,200 baud) 2 front panel USB device ports	
Optional I/O	Universal Analog Output Board (all user-definable): 4 x isolated voltage outputs (5 V, 10 V) 3 x individually isolated current outputs (4-20 mA) Digital I/O Expansion Board includes: 3 x isolated digital input controls (fixed) 5 x isolated digital output controls (user-definable) 3 x form C relay alarm outputs (user-definable)	
Temperature Range	0 - 40°C operating, 0 - 40°C EPA Designation (N300 only)	
Humidity Range	0-95% RH, Non-Condensing	
Temp Coefficient	< 0.05 % per °C (minimum 50 ppb/°C)	
Voltage Coefficient	< 0.05 % per V	
Dimensions (HxWxD)	7" x 17" x 24.3" (178 mm x 432 mm x 617 mm)	
Weight	40 lbs (18.1 kg)	
Environmental Conditions	Installation Category (Over voltage Category) II Pollution Degree 2 For outdoor use only, to ≤ 2000 m altitude	

Note: All specifications are based on constant conditions

Table 1-2. O₂ Sensor Option Specifications

PARAMETER	DESCRIPTION
Ranges	0-1% to 0-100% user selectable. Dual ranges and auto-ranging supported.
Zero Noise ¹	<0.02% O ₂
Lower Detectable Limit ²	<0.04% O ₂
Zero Drift (24 hours) ³	<± 0.02% O ₂
Span Noise ¹	<± 0.05% O ₂
Accuracy	(intrinsic error) <± 0.1% O ₂
Linearity	<± 0.1 % O ₂
Temp Coefficient	<± 0.05% O ₂ /°C,
Rise and Fall Time	<60 seconds to 95%

¹ As defined by the USEPA

² Defined as twice the zero noise level by the USEPA

³ Note: zero drift is typically <± 0.1% O₂ during the first 24 hrs of operation

Table 1-3. CO₂ Sensor Option Specifications

PARAMETER	DESCRIPTION
Ranges	0-1% to 0-20% user selectable. Dual ranges and auto-ranging supported.
Zero Noise ¹	<0.02% CO ₂
Lower Detectable Limit ²	<0.04% CO ₂
Zero Drift (24 hours)	<± 0.02% CO ₂
Zero Drift (7 days)	<± 0.05% CO ₂
Span Noise ¹	<± 0.1% CO ₂
Span Drift (7 days)	<± 0.1% CO ₂
Accuracy	<± (1.5% of range + 2% of reading)
Linearity	<± 0.1% CO ₂
Temperature Coefficient	<± 0.01% CO ₂ /°C
Rise and Fall Time	<60 seconds to 95%

¹ As defined by the USEPA

² Defined as twice the zero noise level by the USEPA



N300, N300M

1.2 EPA DESIGNATION

Teledyne API's Model N300, Gas Filter Correlation Carbon Monoxide Analyzer, is designated as a US EPA Reference Method, Designation Number RFCA-1093-093 for CO measurement. The official "List of Designated Reference and Equivalent Methods" is published in the U.S. Federal Register.

1.3 COMPLIANCE AND CERTIFICATIONS

This product is CE compliant and adheres to the Low Voltage and Electromagnetic Compatibility Directives.

For any other certifications, please refer to our website for the product specifications sheet.

2. GETTING STARTED

This Section addresses unpacking, connecting, and initializing the instrument, getting an overview of the menu system, and setting up/configuring the functions.

2.1 UNPACKING



CAUTION - GENERAL SAFETY HAZARD

To avoid personal injury, always use two persons and proper lift and carry techniques to move/relocate the analyzer.

ATTENTION

COULD DAMAGE INSTRUMENT AND VOID WARRANTY

Printed Circuit Assemblies (PCAs) are sensitive to electro-static discharges too small to be felt by the human nervous system. Failure to use Electro-Static Discharge (ESD) protection when working with electronic assemblies will void the instrument warranty. Refer to the manual, Fundamentals of ESD, PN 04786, which can be downloaded from our website at <http://www.teledyne-api.com>.

ATTENTION

COULD DAMAGE INSTRUMENT AND VOID WARRANTY

Do not operate this instrument without first removing dust plugs from SAMPLE and EXHAUST ports on the rear panel.

Note

Teledyne API recommends that you store shipping containers and materials for future use if/when the instrument should be returned to the factory for repair and/or calibration service. See Warranty statement in this manual and Return Merchandise Authorization (RMA) on our Website at <http://www.teledyne-api.com>.

Verify that there is no apparent external shipping damage. If damage has occurred, please advise the shipper first, then Teledyne API.

Included with your instrument is a printed record of the final performance characterization performed on your instrument at the factory. This record, titled Final Test and Validation Data Sheet, is an important quality assurance and calibration record and should be placed in the quality records file for this instrument.

With no power to the unit, carefully remove the top cover of the instrument and check for internal shipping damage by carrying out the following steps:

1. Carefully remove the top cover and check for internal shipping damage.
 - a. Remove the screws located on the instrument's sides.
 - b. Slide cover backward until it clears the instrument's front bezel.
 - c. Lift cover straight up.
2. Inspect instrument interior to ensure all circuit boards and other components are intact and securely seated.
3. Check the connectors of the various internal wiring harnesses and pneumatic hoses to ensure they are firmly and securely seated.
4. Verify that all of the optional hardware ordered with the unit has been installed. These are listed on the paperwork accompanying the instrument.



WARNING – ELECTRICAL SHOCK HAZARD

Never disconnect or reconnect PCAs, wiring harnesses or electronic subassemblies while instrument is under power.

2.1.1 VENTILATION CLEARANCE

Whether the analyzer is set up on a bench or installed into an instrument rack, be sure to leave sufficient ventilation clearance.

Table 2-1. Ventilation Clearance

AREA	MINIMUM REQUIRED CLEARANCE
Back of the instrument	10 cm / 4 in
Sides of the instrument	2.5 cm / 1 in
Above and below the instrument	2.5 cm / 1 in

Various rack mount kits are available for this analyzer. Contact Sales for more information.

2.2 INSTRUMENT LAYOUT

Instrument layout includes front panel, rear panel connectors, and internal chassis layout.

2.2.1 FRONT PANEL

The front panel (Figure 2-1) includes two USB ports for peripheral device connections, which can be used with mouse and keyboard as alternatives to the touchscreen interface, or with flash drive for uploads/downloads (devices not included).

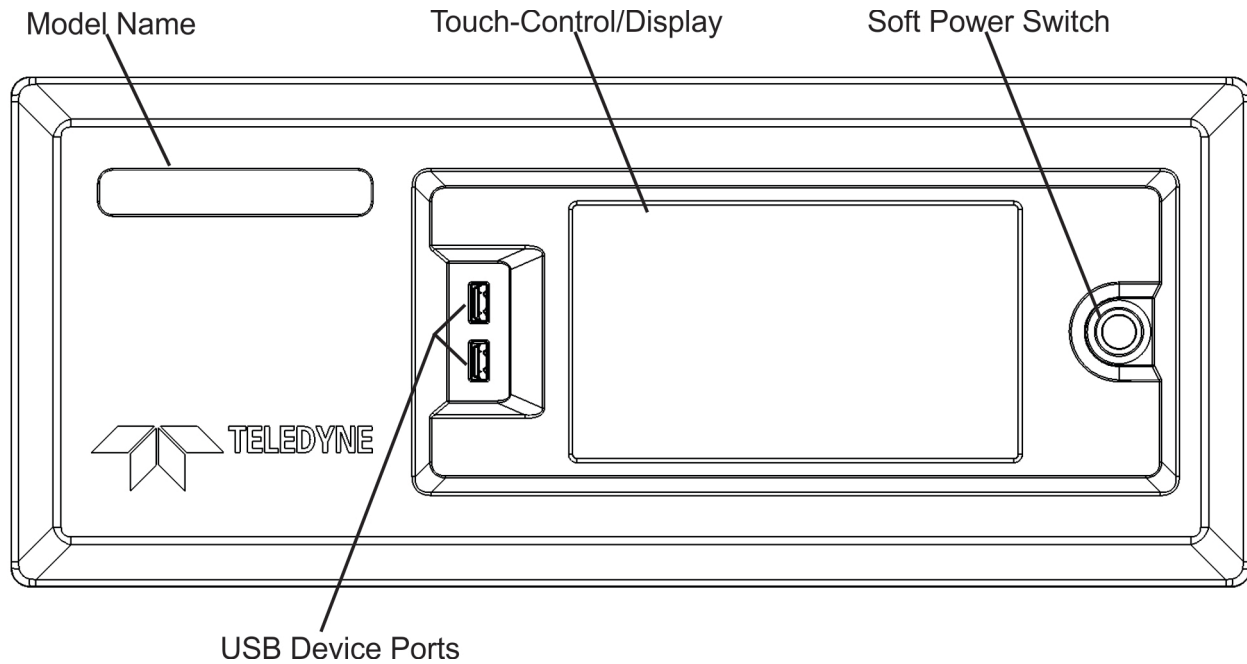

Figure 2-1. Front Panel Layout

2.2.2 REAR PANEL

Figure 2-2 shows the layout of the rear panel, and Table 2-2 provides descriptions.

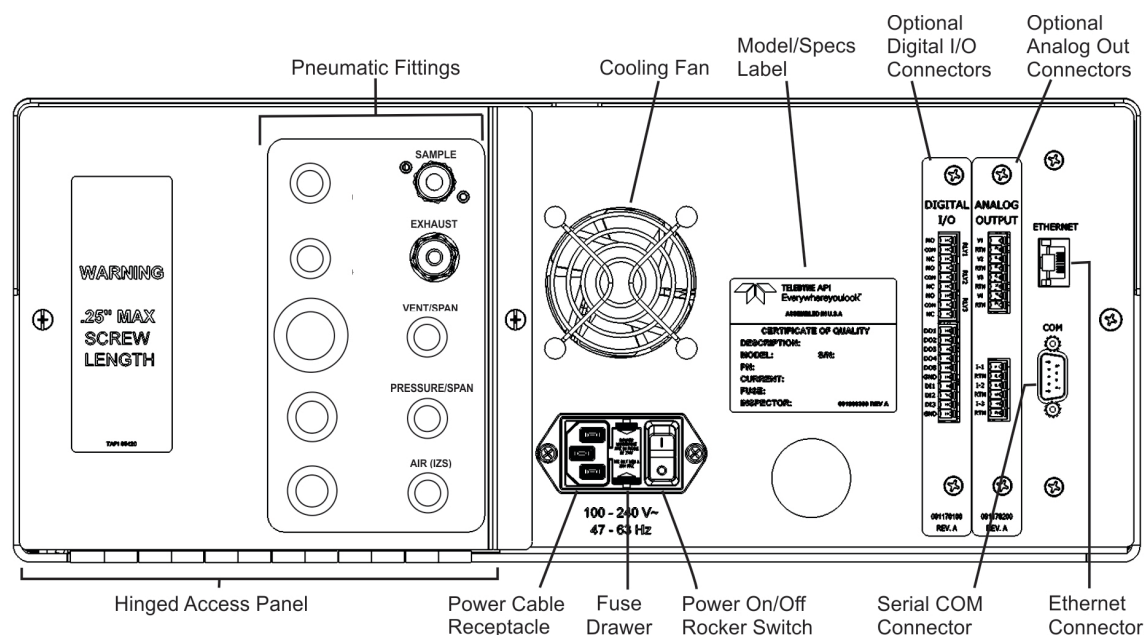



Figure 2-2. Rear Panel Layout

Table 2-2. Rear Panel Description

COMPONENT	FUNCTION
SAMPLE	Connect a gas line from the source of sample gas here. Calibration gases can also enter here on units without zero/span/shutoff valve options installed.
EXHAUST	Connect an exhaust gas line of not more than 10 meters long here that leads outside the shelter or immediate area surrounding the instrument. The line must be 1/4" tubing or greater.
VENT SPAN (with option)	On units with zero/span valve option installed, connect a gas line to the source of calibrated span gas here.
PRESSURE/SPAN (with option)	Used as a second cal gas input line when instrument is configured with zero/span valves and a dual gas option, or as a cal gas vent line when instrument is configured with a pressurized span option (<i>Call factory for details</i>).
AIR (IZS) (with option)	Internal Zero Air: On units with zero/span/shutoff valve options installed but no internal zero air scrubber attach a gas line to the source of zero air here.
Cooling fan	Pulls ambient air into chassis through side vents and exhausts through rear (software controlled to Box Temp setpoint).
Model/specs label	Identifies the analyzer model number and provides power specs.
	Power cable receptacle Connector for three-prong cord to apply AC power to the analyzer CAUTION! The cord's power specifications (specs) MUST comply with the power specs on the analyzer's rear panel label
	Power On/Off Switch Rocker switch to power unit on or off. CAUTION! Prior to powering OFF, use front panel button for preliminary internal "soft" power-down to protect components from damage.
Fuse drawer	For circuit protection
DIGITAL I/O Option	For remotely activating the zero and span calibration modes.
ANALOG OUT Option	For voltage or current loop outputs to a strip chart recorder and/or a data logger.
ETHERNET	Connector for network or Internet remote communication, using Ethernet cable.
COM	Serial communications port for RS-232

2.2.3 INTERNAL CHASSIS

Figure 2-3 shows the N300 internal layout. Figure 2-4 shows the N300M internal layout.

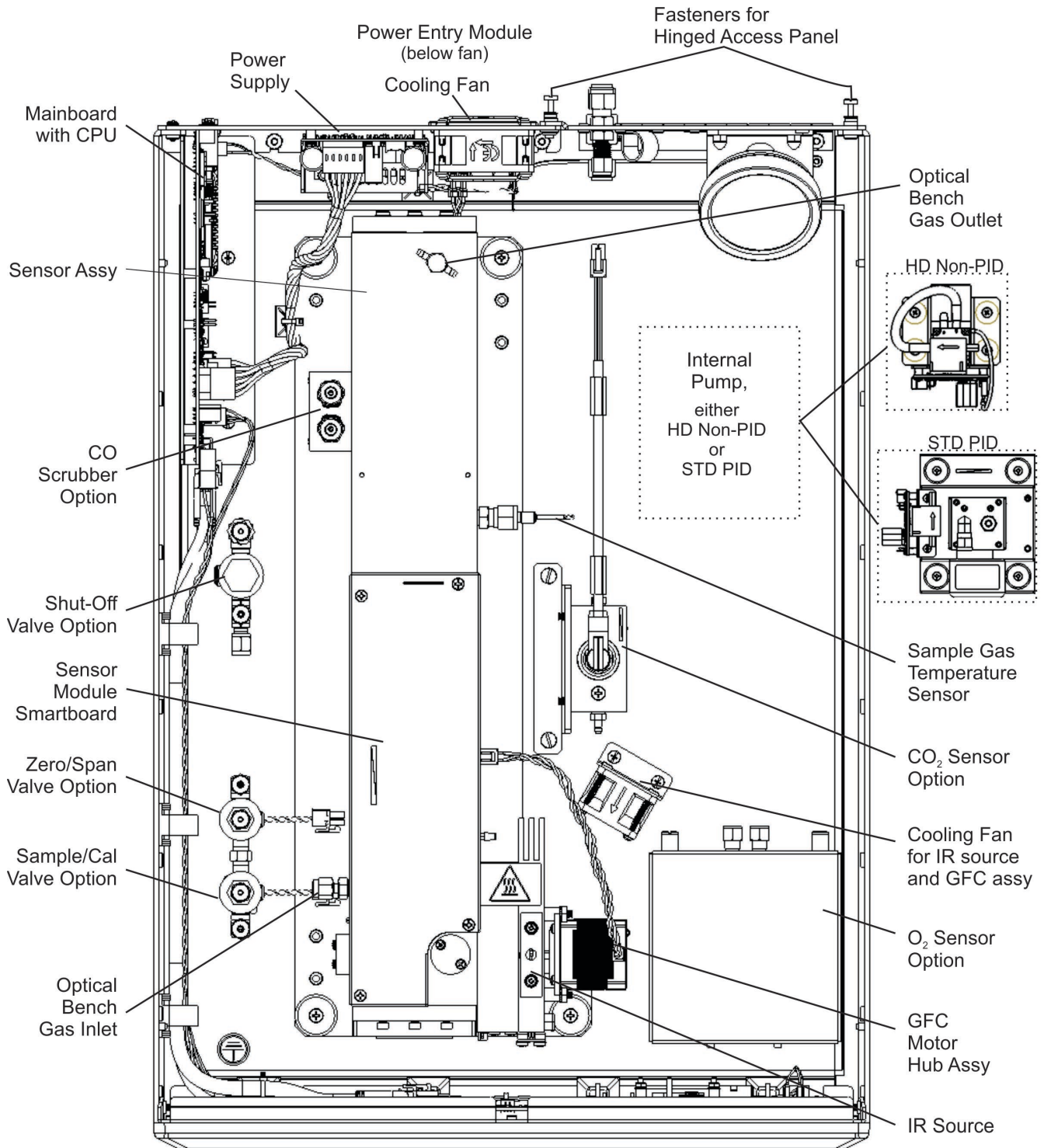

Figure 2-3. Internal Layout – N300

N300, N300M

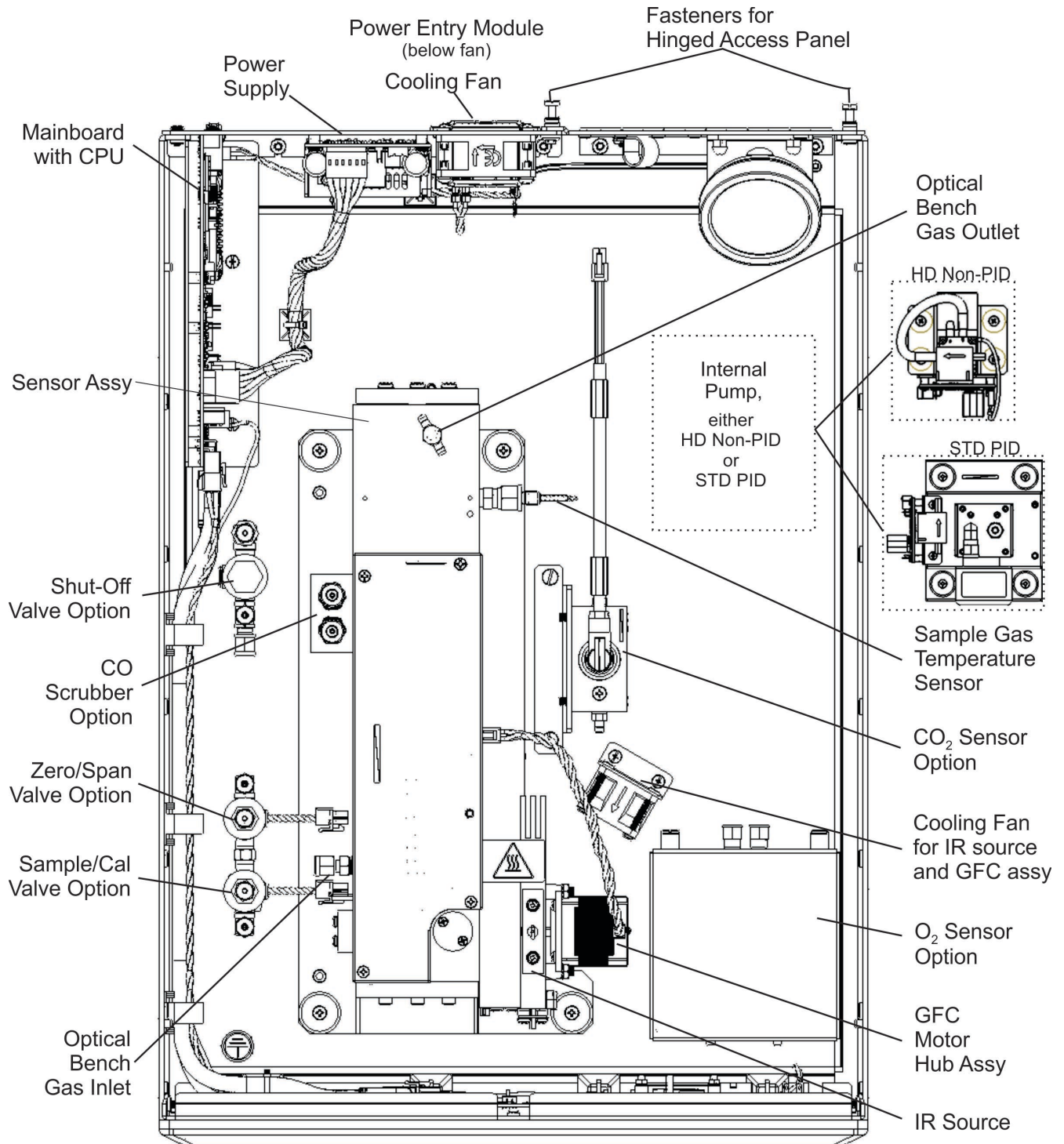

Figure 2-4. Internal Layout – N300M



N300, N300M

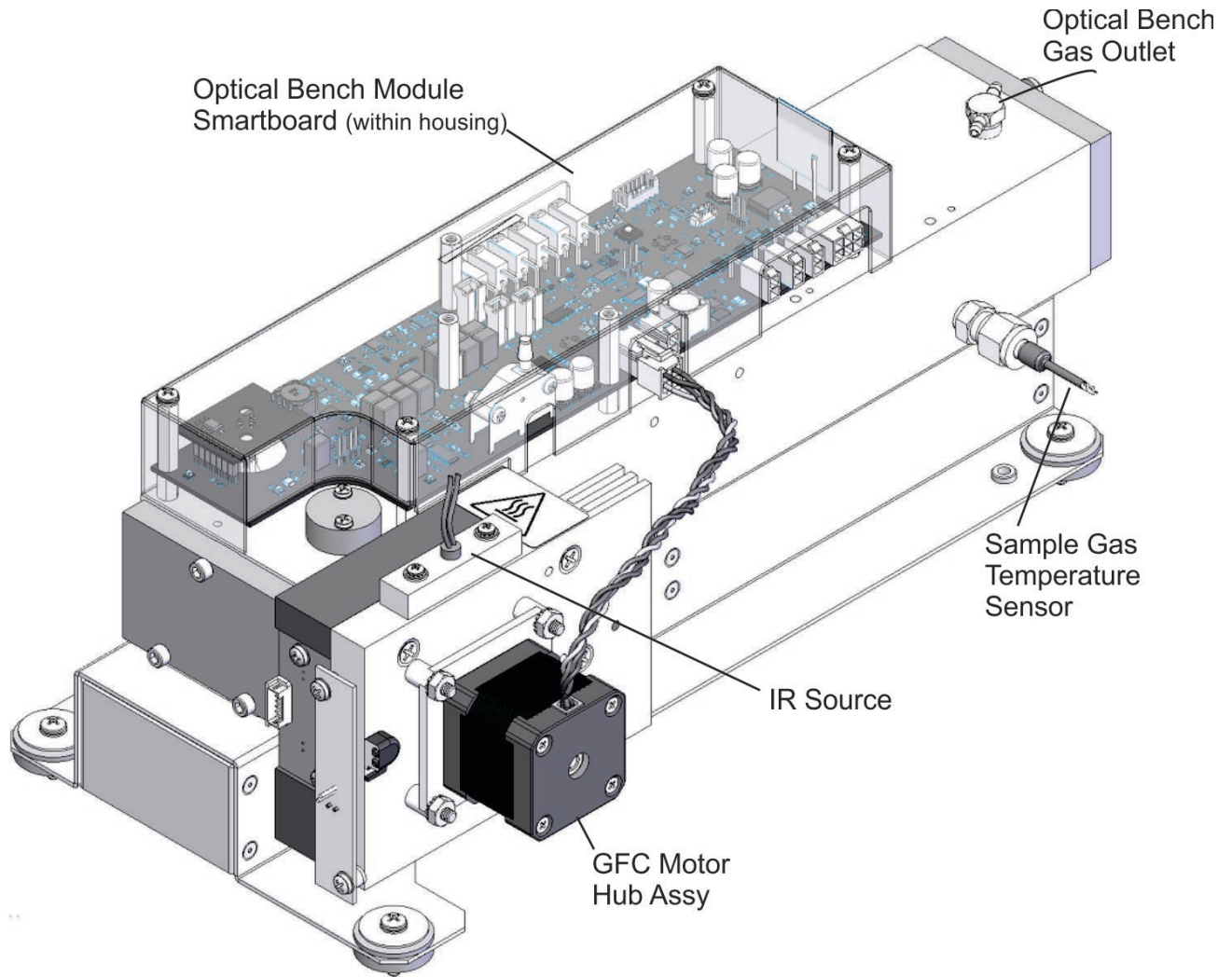

Figure 2-5. Optical Bench Layout (shorter bench, N300M, shown)



2.3 CONNECTIONS AND STARTUP

This Section presents the electrical (Section 2.3.1) and pneumatic (Section 2.3.2) connections for setup and preparing for instrument operation.

2.3.1 ELECTRICAL CONNECTIONS

Note

To maintain compliance with EMC standards, cable must be no longer than 3 meters for all I/O connections. Ensure that there is enough space to easily disconnect this instrument from the power source if necessary.

Teledyne API recommends that you store shipping containers and materials for future use if/when the instrument should be returned to the factory for repair and/or calibration service.



WARNING – Electrical Shock Hazard

- High Voltages are present inside the instrument's case.
- Power connection must have functioning ground connection.
- Do not defeat the ground wire on power plug.
- Turn off instrument power before disconnecting or connecting electrical subassemblies.
- Do not operate with cover off.



CAUTION – Avoid Damage to the Instrument

Ensure that the AC power voltage matches the voltage indicated on the instrument's model/specs label before plugging it into line power.

2.3.1.1 CONNECTING POWER

Important

COULD CAUSE LOSS OR CORRUPTION OF DATA

Never power off the instrument from the rear panel Hard Power switch before first using the front panel Soft Power switch, which triggers the Supervisory chip to safely shut down the internal computerized components and preserve data. Press and hold the front panel Soft Power switch until the instrument stops running; the LED state then changes from solid lit to blinking, at which time either the rear panel Hard Power switch can be used to finish powering off the instrument if needed, or the Soft Power switch can be pressed again later to restart the instrument.

Attach the power cord between the instrument's AC power connector and a power outlet capable of carrying at least the rated current at your AC voltage range and ensure that it is equipped with a functioning earth ground. It is important to adhere to all safety and cautionary messages.



N300, N300M

2.3.1.2 CONNECTING ANALOG OUTPUTS OPTION

The optional rear panel Analog Output board offers several channels that can be mapped to reflect various operating values in the analyzer, including concentration values, temperatures, pressures, etc. These mappings are not configured by default and must be set by the user.

The four **voltage** outputs (0-5 V or 0-10 V) are isolated from the instrument but share a common ground. The three **current** outputs are individually isolated from each other and from the instrument.

To access these signals, attach a strip chart recorder and/or data-logger to the appropriate analog output connections, and configure through the Setup>Analog Outputs menu.

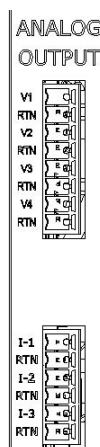

Figure 2-6. Analog Outputs Connectors Panel Option

Table 2-3. Analog Output Pin Assignments

PIN	OUTPUT	DESCRIPTION
Isolated Voltage Outputs		
V1	V +	User definable through the Setup>Analog Outputs menu.
RTN	Ground	
V2	V +	
RTN	Ground	
V3	V +	
RTN	Ground	
V4	V +	
RTN	Ground	
Isolated Current Outputs		
I-1	I Out +	User definable through the Setup>Analog Outputs menu.
RTN	I Out -	
I-2	I Out +	
RTN	I Out -	
I-3	I Out +	
RTN	I Out -	



N300, N300M

2.3.1.3 CONNECTING THE DIGITAL I/O EXPANSION BOARD OPTION

The connections on this board include three relay alarms, five digital outputs, and three isolated digital input controls. The **Relays** can be mapped to reflect various internal instrument conditions and states. The **Outputs** are isolated from the instrument and consist of open collector transistors with a common ground; they can be mapped to reflect various internal instrument conditions and states; they can be used to interface with devices that accept logic-level digital inputs, such as Programmable Logic Controllers (PLCs). The **Inputs** are also isolated but share the same ground as the Outputs; they will work with relays, open collectors, or 3.3 V – 24 V logic. Pull low to activate. DI1 and DI2 are fixed (not mappable) for remote zero and span calibrations. DI1 and DI2 are fixed (not mappable) for remote zero and span calibrations.

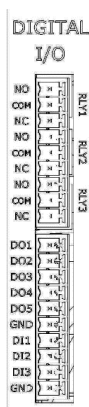

Figure 2-7. Digital I/O Connector Panel Option

Table 2-4. Digital I/O Pin Assignments

PIN	DESCRIPTION	
Relays		
NO	RLY 1	Relay Alarms, user-configurable through the Setup>Digital Outputs menu.
COM		
NC		
NO	RLY 2	
COM		
NC		
NO	RLY 3	
COM		
NC		
Digital Outputs and Inputs		
DO1	Digital Outputs mappable in the Setup>Digital Outputs menu, and viewable in the Utilities>Diagnostics>Digital Outputs menu	
DO2		
DO3		
DO4		
DO5		
GND	Ground	
DI1	Digital Input1 = Remote Zero Cal	
DI2	Digital Input2 = Remote Span Cal	
DI3	(Digital Input3 not used)	
	View status in Utilities>Diagnostics>Digital Inputs menu	
GND	Ground	

2.3.1.4 CONNECTING THE COMMUNICATION INTERFACES

For remote communications, the rear panel provides Ethernet or RS-232 connectors. In addition to using the appropriate cables, the communication method must be configured using the SETUP>COMM menu, Section 2.5.10).

ETHERNET CONNECTION

For network or Internet communication with the analyzer, connect an Ethernet cable from the analyzer's rear panel Ethernet interface connector to an Ethernet access port. Although Ethernet is DHCP-enabled by default, it should be manually configured (Section 2.5.10.3) with a static IP address.

SERIAL CONNECTION

Received from the factory, the analyzer COM port is set up for RS-232 communications with data communication equipment (DCE). This port can be reconfigured for RS-232 communications with data terminal equipment (DTE) by jumpering the pins on JP1 as indicated in Table 2-5 (view/edit software settings Table 2-14).



WARNING – Electrical Shock Hazard

Disconnect all power before performing any operation that requires entry into the interior of the analyzer.

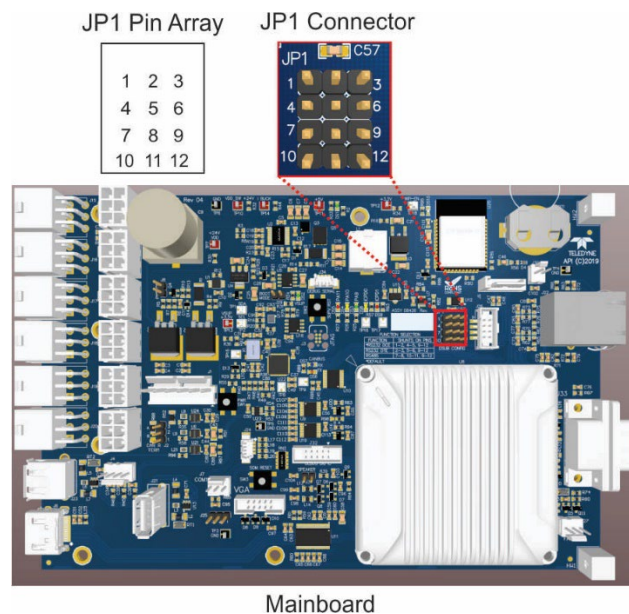

Figure 2-8. Mainboard JP1 Location and Pin Arrangements



N300, N300M

Table 2-5. JP1 Configurations for Serial Communication

Function	Jumpers	DSub Pins	
		2	3
DCE RS232 (default)	1-2, 4-5, 9-12	232Tx	232Rx
DTE RS232	2-3, 5-6, 9-12	232Rx	232Tx

- **Baud rate:** 115200 bits per second (baud)
- **Data Bits:** 8 data bits with 1 stop bit
- **Parity:** None

2.3.2 PNEUMATIC CONNECTIONS

This section provides pneumatic connection and setup instructions for basic and valve option configurations. Pneumatic flow diagrams are shown in Section 2.3.3. Calibration instructions are provided in Section 4.

Before making the pneumatic connections, carefully note the following cautionary and special messages:



CAUTION – General Safety Hazard

- **Carbon monoxide (CO) is a toxic gas. Do not vent calibration gas or sample gas into enclosed areas.**
- **Obtain a Safety Data Sheet (SDS) for this material. Read and rigorously follow the safety guidelines described there.**
- **Sample and calibration gases should only come into contact with PTFE (Teflon), FEP, glass, stainless steel or brass.**
- **The exhaust from the analyzer's internal pump MUST be vented outside the shelter or immediate area surrounding the instrument.**
- **It is important to conform to all safety requirements regarding exposure to CO.**



N300, N300M

ATTENTION

COULD DAMAGE INSTRUMENT AND VOID WARRANTY

Maximum Pressure:

Ideally the maximum pressure of any gas at the sample inlet should equal ambient atmospheric pressure and should NEVER exceed 1.5 in-hg above ambient pressure.

Venting Pressurized Gas:

In applications where any gas (span gas, zero air supply, sample gas is) received from a pressurized manifold, a vent must be provided to equalize the gas with ambient atmospheric pressure before it enters the analyzer to ensure that the gases input do not exceed the maximum inlet pressure of the analyzer, as well as to prevent back diffusion and pressure effects. These vents should be:

- at least 0.2m long
- no more than 2m long
- vented outside the shelter or immediate area surrounding the instrument.

Dust Plugs:

Remove dust plugs from rear panel exhaust and supply line fittings before powering on/operating instrument. These plugs should be kept for reuse in the event of future storage or shipping to prevent debris from entering the pneumatics.

IMPORTANT

LEAK CHECK

Run a leak check once the appropriate pneumatic connections have been made; check all pneumatic fittings for leaks using the procedures defined in Section 5.6.3.



N300, N300M

2.3.2.1 CRITICAL TUBING, PRESSURE, VENTING AND EXHAUST REQUIREMENTS

The requirements presented in this section apply to all pneumatic connection instructions.

Tubing:

- PTFE material
- Outer diameter (OD) minimum ¼"
- Min/max length 2 meters to 10 meters

Pressure:

- All Sample gas pressure must be at ambient atmospheric pressure, do not run a pressurized sample line greater than 1.0 psig.

Venting (to prevent back diffusion and pressure effects):

- Run tubing outside the enclosure or at least away from immediate area surrounding the instrument.

Exhaust Outlet:

- Run tubing outside the enclosure.

Calibration Gas Sources:

- The source of calibration gas or zero air is also attached to the **SAMPLE** inlet, but only when a calibration operation is actually being performed.

SPAN GAS FOR MULTIPOINT CALIBRATION

Some applications, such as EPA monitoring, require a multipoint calibration procedure where span gases of different concentrations are needed. We recommend using a bottle of calibrated CO gas of higher concentration in conjunction with a gas dilution calibrator such as from the TAPI 700-Series. This type of calibrator precisely mixes a high concentration gas with zero air (both supplied externally) to accurately produce span gas of the correct concentration. Linearity profiles can be automated with this model and run unattended over night.



N300, N300M

2.3.2.2 PNEUMATIC CONNECTIONS: BASIC CONFIGURATION

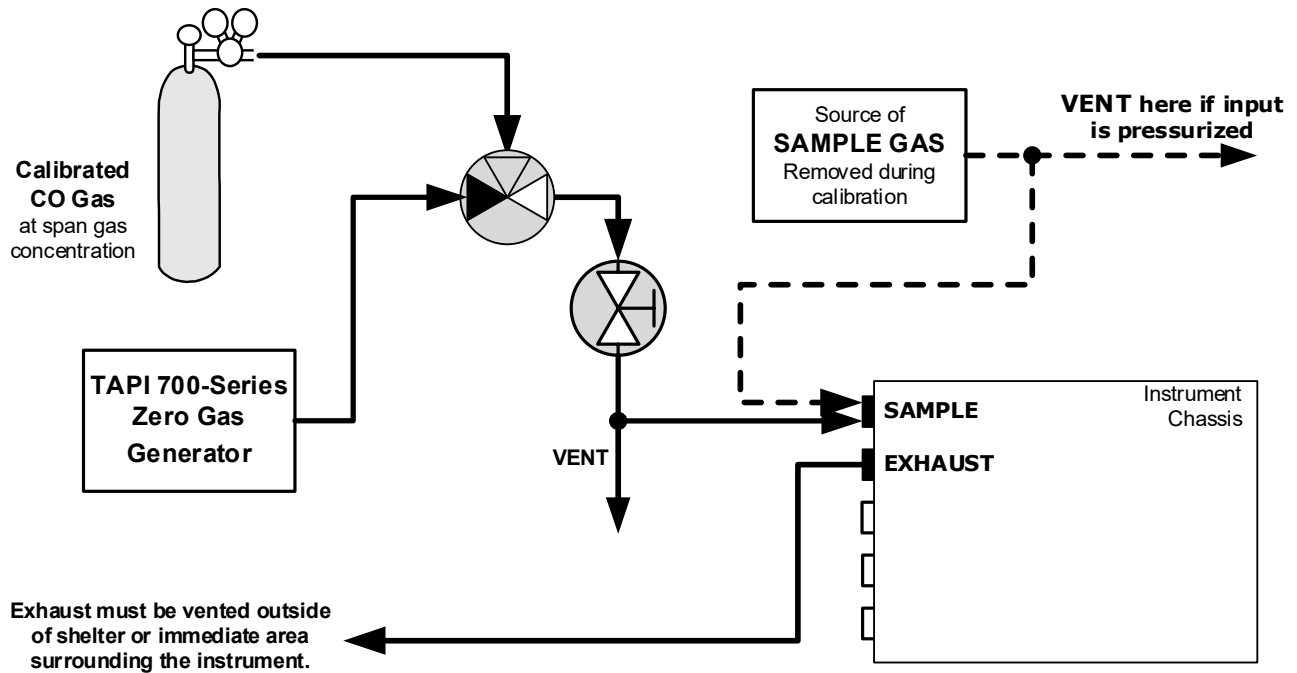

Figure 2-9. Pneumatic Connections – Basic Configuration Using Bottled Span Gas

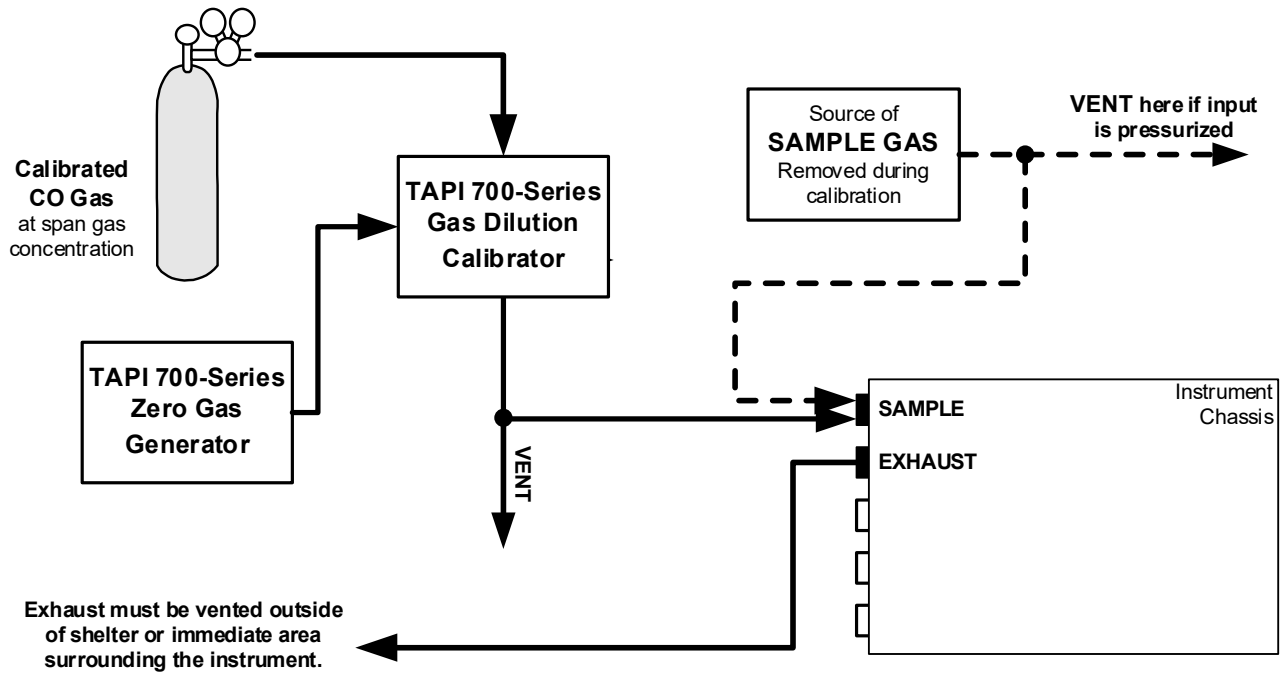

Figure 2-10. Pneumatic Connections – Basic Configuration Using Gas Dilution Calibrator



N300, N300M

SAMPLE GAS SOURCE

Attach a sample inlet line to the SAMPLE inlet port. The sample input line should not be more than 2 meters long.

- Maximum pressure of any gas at the sample inlet should not exceed 1.5 in-hg above ambient pressure and ideally should equal ambient atmospheric pressure.
- In applications where the sample gas is received from a pressurized manifold, a vent must be placed on the sample gas before it enters the analyzer.

CALIBRATION GAS SOURCES

The source of calibration gas is also attached to the SAMPLE inlet, but only when a calibration operation is actually being performed.

Note Zero air and span gas inlets should supply their respective gases in excess of the 800 cc³/min demand of the analyzer.

INPUT GAS VENTING

The span gas, zero air supply and sample gas line MUST be vented in order to ensure that the gases input do not exceed the maximum inlet pressure of the analyzer as well as to prevent back diffusion and pressure effects. These vents should be:

- At least 0.2m long;
- No more than 2m long and;
- Vented outside the shelter or immediate area surrounding the instrument.

EXHAUST OUTLET

Attach an exhaust line to the analyzer's EXHAUST outlet fitting. The exhaust line should be:

- PTFE tubing; minimum O.D. 1/4";
- A maximum of 10 meters long;
- Vented outside the N300/N300M Analyzer's enclosure.

2.3.2.3 PNEUMATIC CONNECTIONS: AMBIENT ZERO/AMBIENT SPAN OPTION

This valve option is intended for applications where:

- Zero air is supplied by a zero air generator such as from the TAPI 700-Series, and
- Span gas is supplied by a gas dilution calibrator such as from the TAPI 700-Series.

Internal zero/span and sample/cal valves control the flow of gas through the instrument, but because the generator and calibrator limit the flow of zero air and span gas, no shutoff valves are required.

See Figure 2-2 for the location of gas inlets.

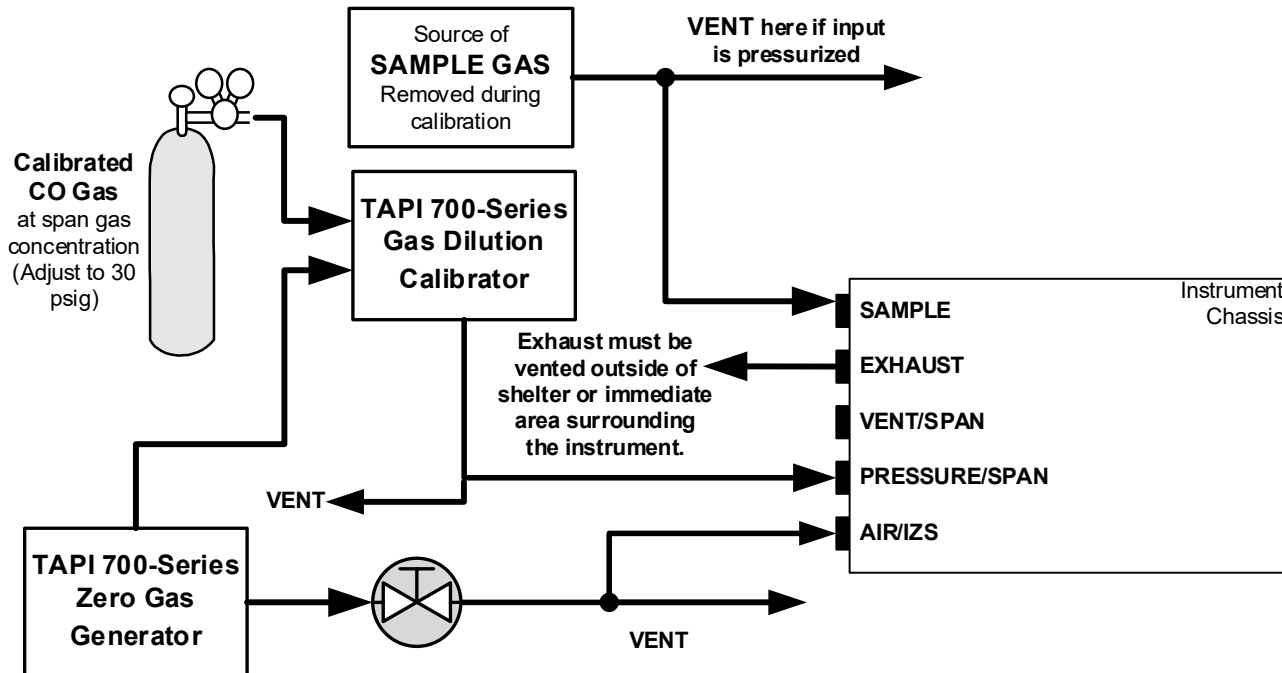

Figure 2-11. Pneumatic Connections – Zero/Span Option

SAMPLE GAS SOURCE

Attach a sample inlet line to the SAMPLE inlet port. The sample input line should not be more than 2 meters long.

- Maximum pressure of any gas at the sample inlet should not exceed 1.5 in-hg above ambient pressure and ideally should equal ambient atmospheric pressure.
- In applications where the sample gas is received from a pressurized manifold, a vent must be placed on the sample gas before it enters the analyzer.

CALIBRATION GAS SOURCES

A vent may or may not be required when a TAPI 700-Series model is used with this option, depending on how that model's output manifold is configured.

SPAN GAS

- Attach a gas line from the source of calibration gas (such as the Dynamic Dilution Calibrator in the TAPI 700-Series) to the PRESSURE/SPAN inlet at 30 psig.

ZERO AIR

- Zero air is supplied via a zero air generator such as from the TAPI 700-Series.
- An adjustable valve is installed in the zero air supply line to regulate the gas flow.

INPUT GAS VENTING

The zero air supply and sample gas line **MUST** be vented in order to ensure that the gases input do not exceed the maximum inlet pressure of the analyzer as well as to prevent back diffusion and pressure effects. These vents should be:

- At least 0.2m long;
- No more than 2m long and;

Vented outside the shelter or immediate area surrounding the instrument.

EXHAUST OUTLET

Attach an exhaust line to the analyzer's EXHAUST outlet fitting. The exhaust line should be:

- PTFE tubing; minimum O.D ¼";
- A maximum of 10 meters long;
- Vented outside the analyzer's enclosure.

2.3.2.4 PNEUMATIC CONNECTIONS: AMBIENT ZERO/PRESSURIZED SPAN OPTION

This option requires that both zero air and span gas be supplied from external sources.

- Span gas will be supplied from a pressurized bottle of calibrated CO gas.
 - A critical flow control orifice, internal to the instrument ensures that the proper flow rate is maintained.
 - An internal vent line ensures that the gas pressure of the span gas is reduced to ambient atmospheric pressure.
 - A SHUTOFF valve preserves the span gas source when it is not in use.
- Zero gas is supplied by either an external scrubber or a zero air generator such from the TAPI 700-Series.

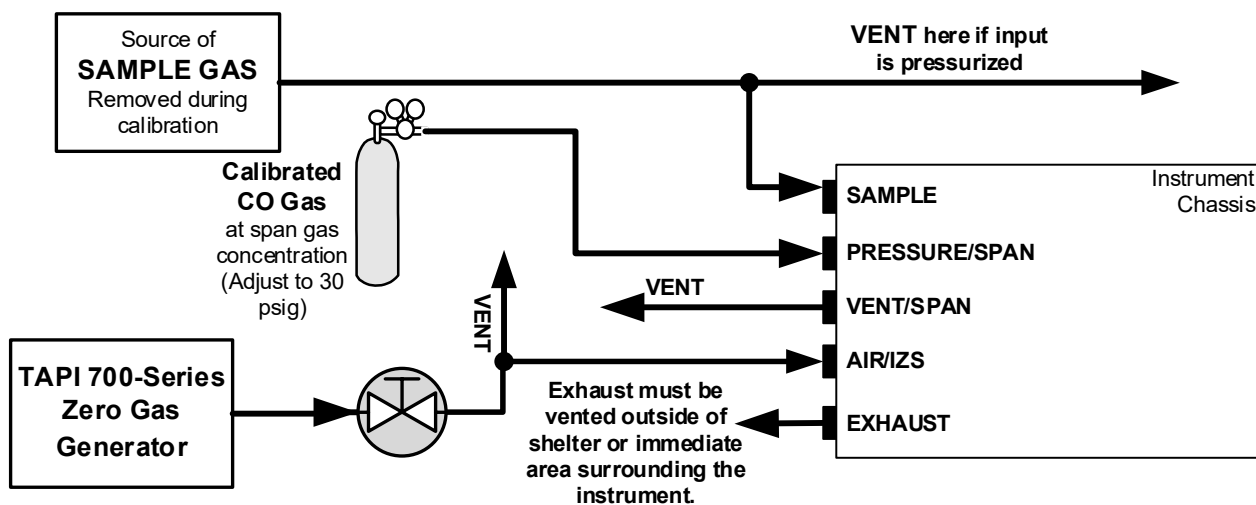

Figure 2-12. Pneumatic Connections – Ambient Zero/Pressurized Span Option



N300, N300M

SAMPLE GAS SOURCE

Attach a sample inlet line to the **SAMPLE** inlet port. The sample input line should not be more than 2 meters long.

- Maximum pressure of any gas at the sample inlet should not exceed 1.5 in-hg above ambient pressure and ideally should equal ambient atmospheric pressure.
- In applications where the sample gas is received from a pressurized manifold, a vent must be placed on the sample gas before it enters the analyzer.

CALIBRATION GAS SOURCES

SPAN GAS

- Attach a gas line from the pressurized source of calibration gas (e.g. a bottle of NIST-SRM gas) to the SPAN inlet at 30 psig.

ZERO AIR

- Zero air is supplied via a zero air generator such as a Teledyne API's T701.
- An adjustable valve is installed in the zero air supply line to regulate the gas flow.

INPUT GAS VENTING

The zero air supply and sample gas line **MUST** be vented in order to ensure that the gases input do not exceed the maximum inlet pressure of the analyzer as well as to prevent back diffusion and pressure effects. These vents should be:

- At least 0.2m long;
- No more than 2m long and;
- Vented outside the shelter or immediate area surrounding the instrument.

A similar vent line should be connected to the VENT SPAN outlet on the back of the analyzer.

EXHAUST OUTLET

Attach an exhaust line to the analyzer's EXHAUST outlet fitting. The exhaust line should be:

- PTFE tubing; minimum O.D ¼";
 - A maximum of 10 meters long;
1. Vented outside the analyzer's enclosure.

2.3.2.5 PNEUMATIC CONNECTIONS: ZERO SCRUBBER/PRESSURIZED SPAN OPTION

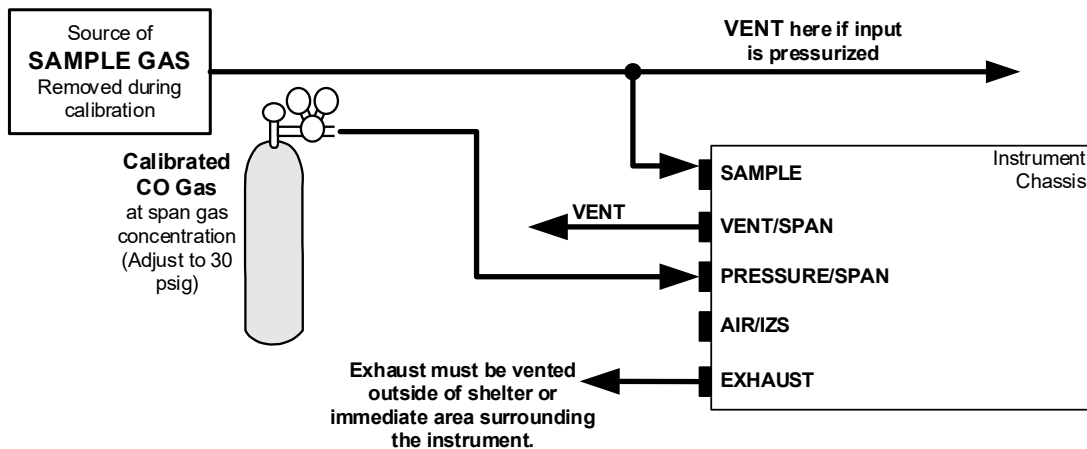

Figure 2-13. Pneumatic Connections – Zero Scrubber/Pressurized Span Option

SAMPLE GAS SOURCE

Attach a sample inlet line to **SAMPLE** inlet port. The sample input line should not be more than 2 meters long.

- Maximum pressure of any gas at the sample inlet should not exceed 1.5 in-hg above ambient pressure and ideally should equal ambient atmospheric pressure.
- In applications where the sample gas is received from a pressurized manifold, a vent must be placed on the sample gas before it enters the analyzer.

CALIBRATION GAS SOURCES

SPAN GAS:

- Attach a gas line from the pressurized source of calibration gas (e.g. a bottle of NIST-SRM gas) to the span inlet.
- Span gas can be generated by a TAPI 700-Series Dynamic Dilution Calibrator.

ZERO AIR:

- Zero air is supplied internally via a zero air scrubber that draws ambient air through the ZERO AIR inlet.

INPUT GAS VENTING

The zero air supply and sample gas line **MUST** be vented in order to ensure that the gases input do not exceed the maximum inlet pressure of the analyzer as well as to prevent back diffusion and pressure effects. These vents should be:

- At least 0.2m long;
- No more than 2m long and;
- Vented outside the shelter or immediate area surrounding the instrument.

A similar vent line should be connected to the VENT SPAN outlet on the back of the analyzer.

EXHAUST OUTLET

Attach an exhaust line to the analyzer's EXHAUST outlet fitting. The exhaust line should be:

- PTFE tubing; minimum O.D. ¼”;
- A maximum of 10 meters long;
- Vented outside the analyzer's enclosure.

2.3.2.6 PNEUMATIC CONNECTIONS: ZERO SCRUBBER/AMBIENT SPAN OPTION (N300)

Not available in the N300M, Option 50H is operationally and pneumatically similar to Option 50A described earlier, except that the zero air is generated by an internal zero air scrubber. This means that the IZS inlet can simply be left open to ambient air.

Internal zero/span and sample/cal valves control the flow of gas through the instrument, but because the generator and calibrator limit the flow of zero air and span gas no shutoff valves are required.

See Figure 2-2 for the location of gas inlets and outlets and span gas no shutoff valves are required.

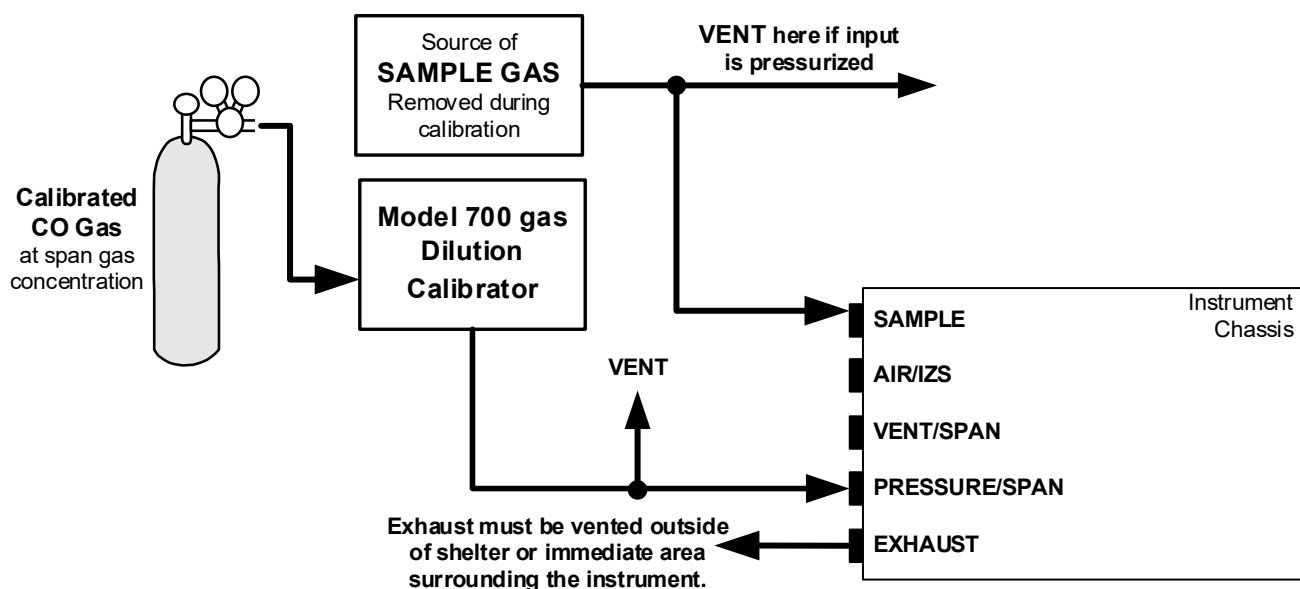

Figure 2-14. N300 Pneumatic Connections – Zero/Span Option

SAMPLE GAS SOURCE

Attach a sample inlet line to **SAMPLE** inlet port. The sample input line should not be more than 2 meters long.

- Maximum pressure of any gas at the sample inlet should not exceed 1.5 in-Hg above ambient pressure and ideally should equal ambient atmospheric pressure.
- In applications where the sample gas is received from a pressurized manifold, a vent must be placed on the sample gas before it enters the analyzer.



N300, N300M

CALIBRATION GAS SOURCES

SPAN GAS

- Attach a gas line from the source of calibration gas (such as a TAPI 700-Series Dynamic Dilution Calibrator) to the **SPAN** inlet.

ZERO AIR

- Zero air is supplied internally via a zero air scrubber that draws ambient air through the IZS inlet.

INPUT GAS VENTING

The zero air supply and sample gas line **MUST** be vented in order to ensure that the gases input do not exceed the maximum inlet pressure of the analyzer as well as to prevent back diffusion and pressure effects. These vents should be:

- At least 0.2m long;
- No more than 2m long and;
- Vented outside the shelter or immediate area surrounding the instrument.

EXHAUST OUTLET

Attach an exhaust line to the analyzer's EXHAUST outlet fitting. The exhaust line should be:

- PTFE tubing; minimum O.D ¼";
- A maximum of 10 meters long;
- Vented outside the analyzer's enclosure.

2.3.3 PNEUMATIC FLOW DIAGRAMS

This Section shows the basic pneumatic flow diagram followed by flow diagrams with options.

2.3.3.1 PNEUMATIC FLOW: BASIC CONFIGURATION

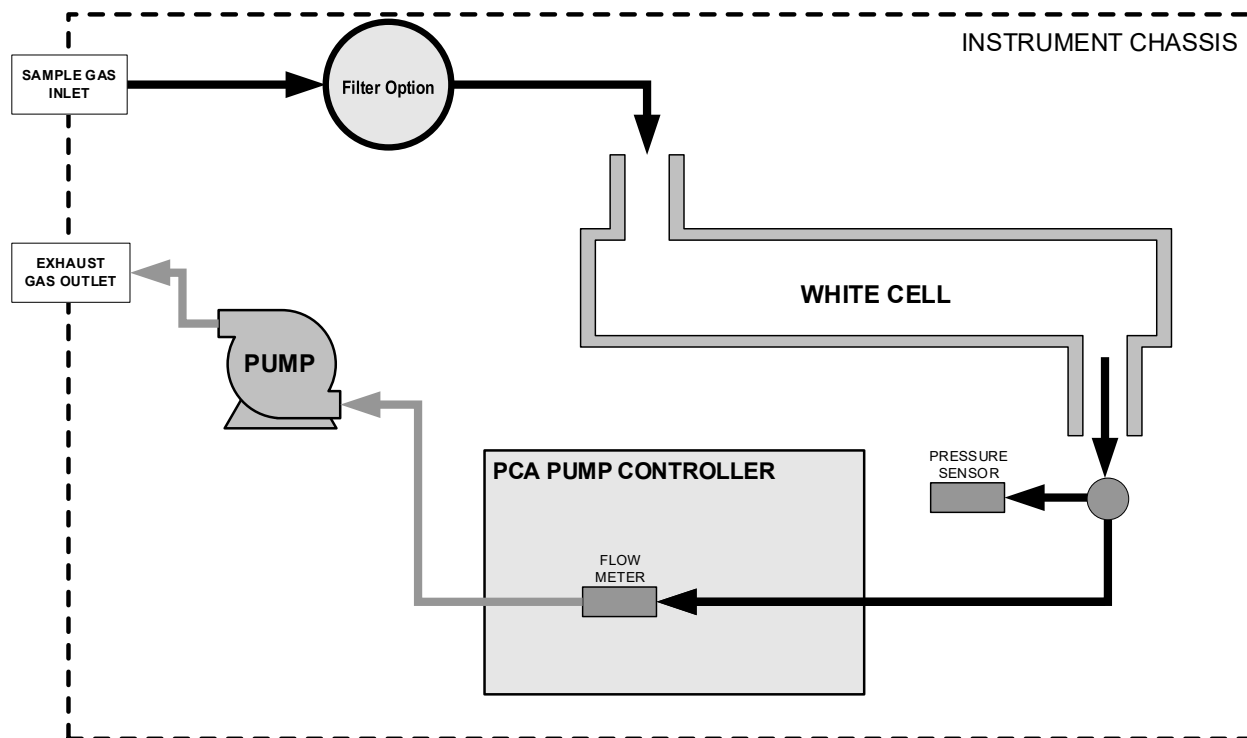

Figure 2-15. N300/N300M Internal Gas Flow (Basic Configuration)

2.3.3.2 PNEUMATIC FLOW: N300 AMBIENT ZERO/AMBIENT SPAN VALVE OPTION

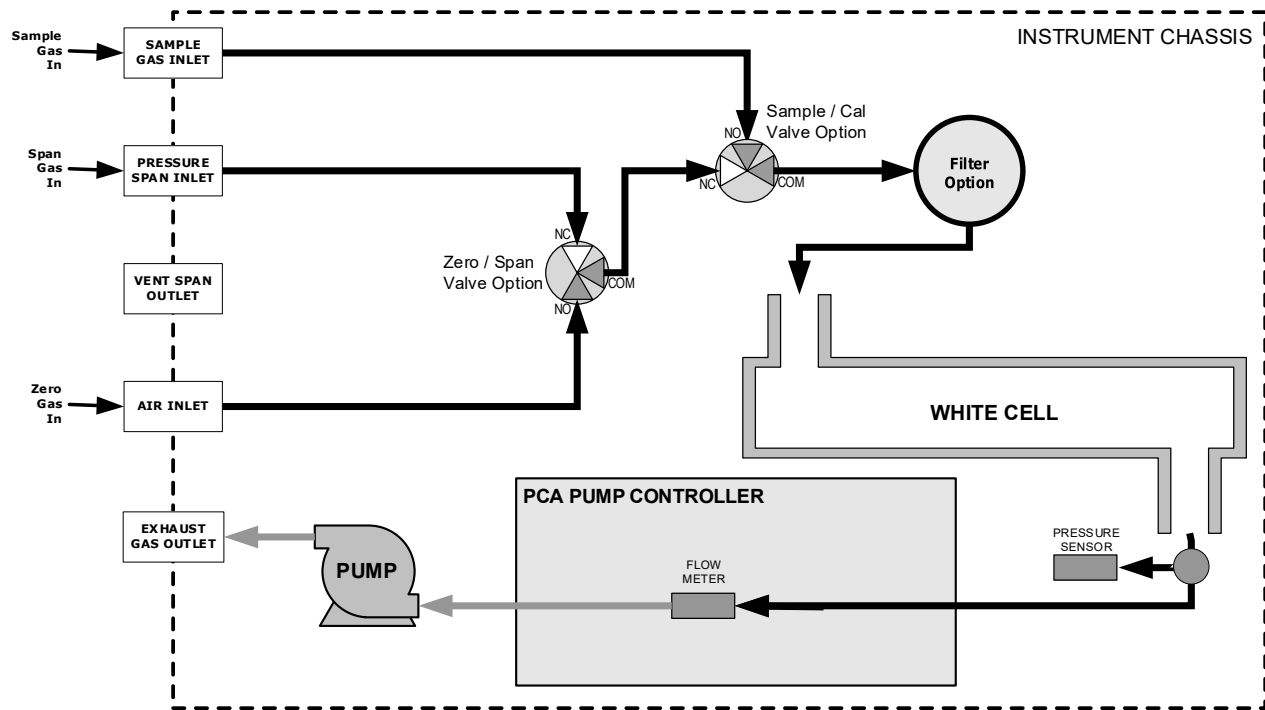

Figure 2-16. N300 Internal Pneumatic Flow for Zero/Span Valves Option

Table 2-6. Zero/Span Valve Option Operating States

MODE	VALVE	CONDITION
SAMPLE (Normal State)	Sample/Cal	Open to SAMPLE inlet
	Zero/Span	Open to IZS inlet
ZERO CAL	Sample/Cal	Open to ZERO/SPAN valve
	Zero/Span	Open to IZS inlet
SPAN CAL	Sample/Cal	Open to ZERO/SPAN valve
	Zero/Span	Open to PRESSURE SPAN inlet

2.3.3.3 PNEUMATIC FLOW: N300 AMBIENT ZERO/PRESSURIZED SPAN OPTION

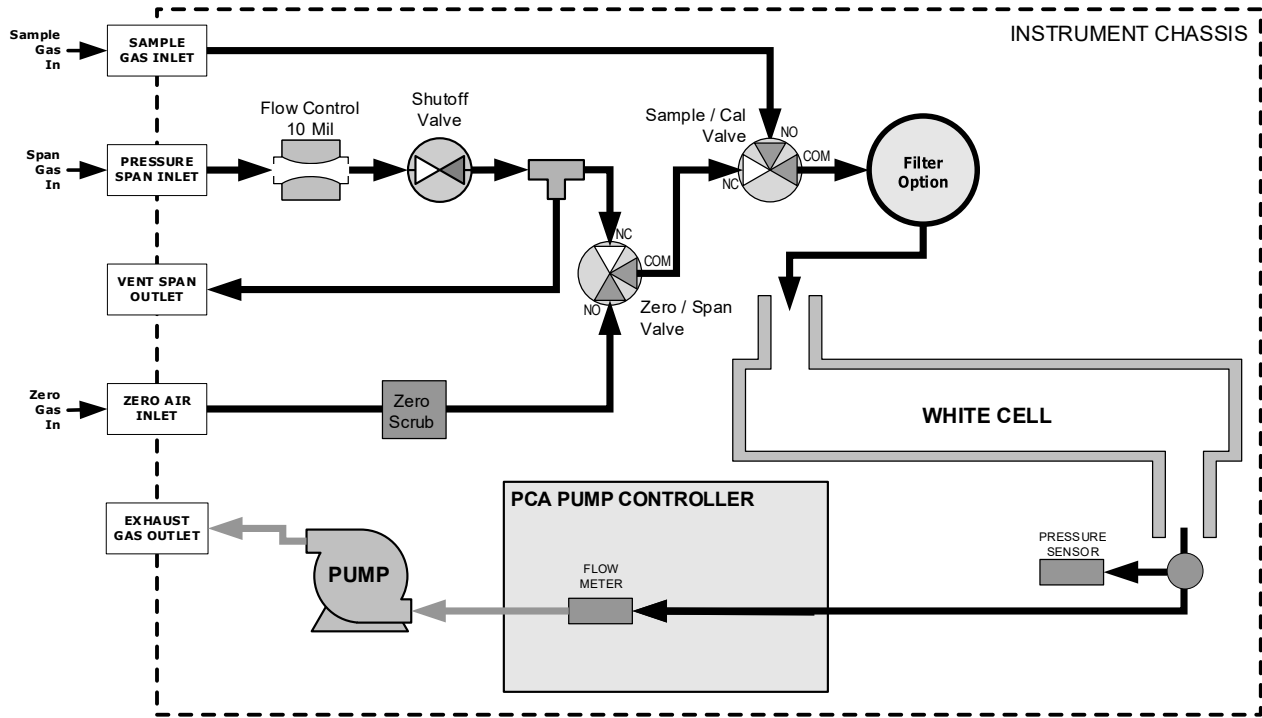

Figure 2-17. N300 Internal Pneumatic Flow for Ambient Zero/Pressurized Span Option

Table 2-7. Operating States for Ambient Zero/Pressurized Span Option

MODE	VALVE	CONDITION
SAMPLE (Normal State)	Sample/Cal	Open to SAMPLE inlet
	Zero/Span	Open to IZS inlet
	Shutoff Valve	Closed
ZERO CAL	Sample/Cal	Open to ZERO/SPAN valve
	Zero/Span	Open to IZS inlet
	Shutoff Valve	Closed
SPAN CAL	Sample/Cal	Open to ZERO/SPAN valve
	Zero/Span	Open to SHUTOFF valve
	Shutoff Valve	Open to PRESSURE SPAN Inlet



2.3.4 STARTUP, FUNCTIONAL CHECKS, AND INITIAL CALIBRATION

IMPORTANT

Impact on Readings or Data

The analyzer's cover must be installed to ensure that the temperatures of the GFC Wheel and absorption cell assemblies are properly controlled.

We recommend reading Section 6 to become familiar with the principles of operation.

When the instrument is first started (Section 2.3.4.1, check its functionality (Section 2.3.4.4) and run an initial calibration (Section 4). Section 2.4 introduces the menu system, and Section 2.5 provides setup/customization instructions.

2.3.4.1 POWER STATUS

The front panel Soft Power switch has a status LED that indicates whether:

- instrument is powered OFF (LED off)
- instrument powered on and internal components in deep sleep mode (LED blinking, achieved by pressing and momentarily holding the soft power button)
- instrument powered on and internal components are operating (LED solid lit; achieved when first powered up; must place in deep sleep mode before power off)

When the instrument is first started (Sections 2.3.4.1 and 2.3.4.2), check its functionality (Section 2.3.4.4) and run an initial calibration (Section 2.3.4.5). Section 2.4 introduces the menu system, and Section 2.5 provides setup/customization instructions.

2.3.4.2 STARTUP

Upon initial startup, a sequence of status screens (Figure 2-18) appear prior to the Home page (Figure 2-19).

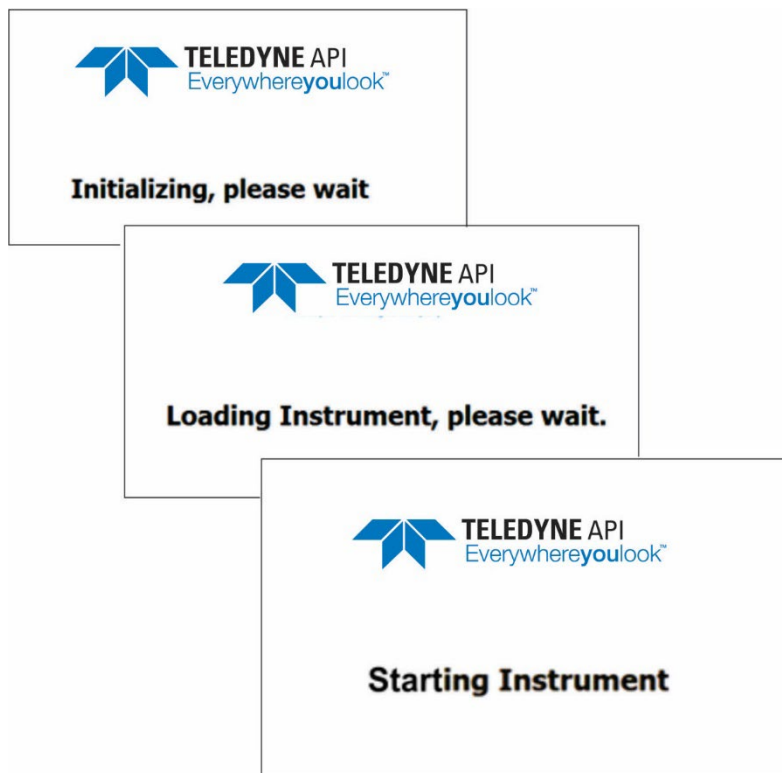

Figure 2-18. Status Screens at Startup

Upon any startup, this instrument should warm up for at least one hour to allow the pump, heaters, IR source, and detector to stabilize, and to provide reliable measurements.

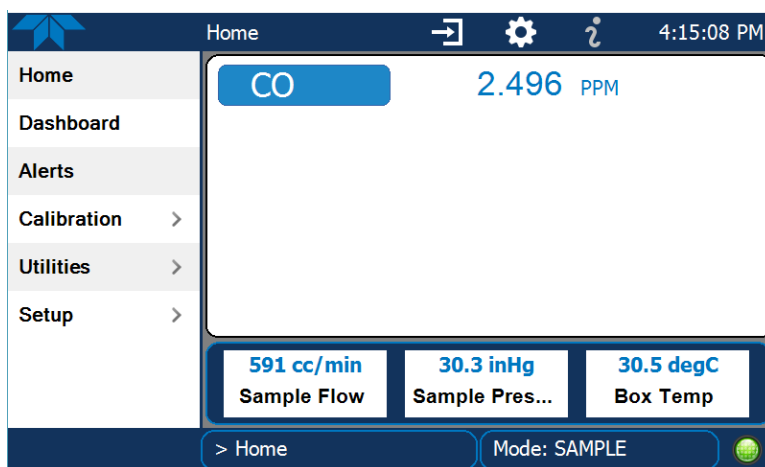

Figure 2-19. Home Page Example

2.3.4.3 ALERTS: WARNINGS AND OTHER MESSAGES

Because internal temperatures and other conditions may be outside the specified limits during the analyzer’s warm-up period, the software will suppress most Alerts for 30 minutes after power up. The Alerts page (Figure 2-20) shows the status of any active warning conditions or user-configured Events. (Section 2.4.3 provides more detailed information about Alerts, and Section 2.5.2 addresses Events).

Alerts can be viewed and cleared via either the Alerts menu or the Alerts shortcut (Caution symbol, bottom right corner of the screen). Although these alerts can be cleared from the Active Alerts page, a history of all alerts remains in the Utilities>Alerts Log page.

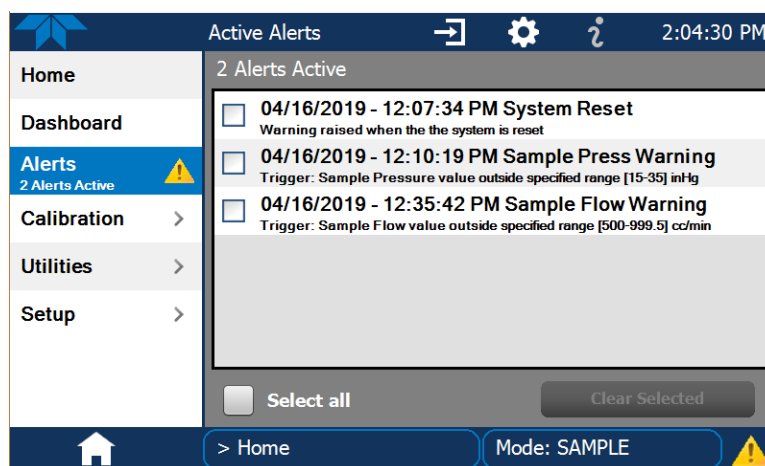

Figure 2-20. Viewing Active Alerts Page

If Alerts about warning conditions persist after the warm up period or after being cleared, investigate their cause using the troubleshooting guidelines in Section 5.7.

2.3.4.4 FUNCTIONAL CHECKS

After warm-up, verify that the software properly supports any hardware options that are installed (Setup>Instrument menu), and that the instrument is functioning within allowable operating parameters. Check the Dashboard page against the instrument’s Final Test and Validation Data sheet, which lists these values as they appeared before the instrument left the factory. (If any functional parameters are not displayed, configure the Dashboard through the Setup>Dashboard menu to add them; see Section 2.4.2).

These functions are also useful tools for diagnosing problems (information provided in Section 5.7.2).

N300, N300M

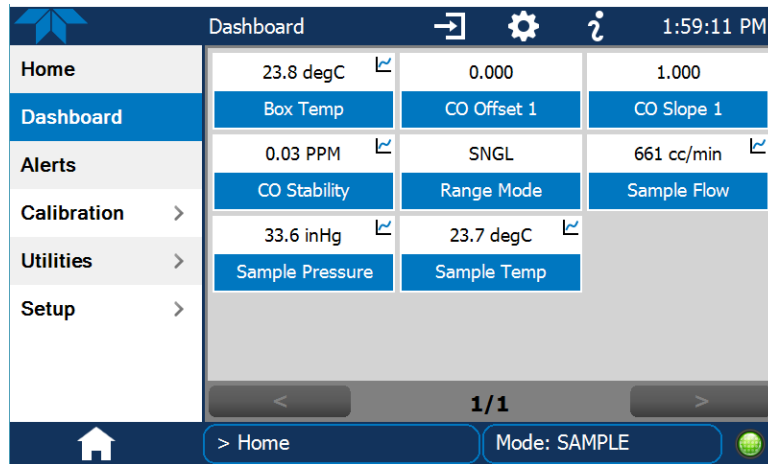

Figure 2-21. Sample Dashboard Page

2.3.4.5 INITIAL CALIBRATION

Before operation begins, the analyzer requires initial calibrations for the location in which it will perform any of the gas analyses. Also, any time an analyzer is moved or its configuration changed, it must be calibrated. The method for performing a calibration differs slightly depending on whether or not any of the available internal zero air or valve options are installed. Follow the appropriate calibration instructions in Section 4.

2.4 MENU OVERVIEW

Table 2-8 describes the main menus and provides cross-references to the respective sections with configuration details.

Table 2-8. Menu Overview

MENU	DESCRIPTION	LOCATION
Home	View and plot concentration readings and other selectable parameter values (Figure 2-23).	Section 2.4.1
Dashboard	View user-selected parameters and their values, some of which can be displayed in a live-plot graph (Figure 2-24).	Section 2.4.2
Alerts	View and clear active Alerts that were triggered by factory-defined Events as well as user-defined Events. (Active and past Alerts are recorded in the Utilities>Alerts Log).	Section 2.4.3
Calibration	Run a multipoint calibration on the gas (or additional gas if 2 nd sensor option installed), and span and zero calibrations (if valve option installed).	Section 4
Utilities	View logs, download data and firmware updates, copy configurations between instruments, and run diagnostics.	Section 2.4.5
Setup	Configure a variety of features and functions through these submenus for customized operation.	Section 2.5
Datalogging	Track and record concentration and calibration data and selectable diagnostic parameters, the reports for which can be viewed in the Utilities>Datalog View menu (Section 2.4.5) and downloaded to a flash drive via the Utilities>USB Utilities menu (Section 2.4.5). Also, select configured Events (Section 2.5.2) and create customized triggers for data logging functions.	Section 2.5.1
Events	Select parameters and define the conditions by which they are to be flagged and recorded in the Alerts log (Section 2.4.3) when they are triggered. Once configured, Events can be used to trigger Datalogs. (Section 2.5.1). Note that some Events are predefined and are not editable.	Section 2.5.2
Dashboard	Monitor instrument functionality (Figure 2-21) via selectable parameters.	Section 2.5.3
Auto Cal (with valve options)	When zero/span valve options installed, configure sequences for automatic calibration checks.	Section 4.2.2.2
Vars	Manually adjust several software variables that define specific operational parameters.	Section 2.5.5
Homescreen	Select up to three parameters to be displayed in the meters (Figure 2-22).	Section 2.5.6
Digital Outputs (option)	Map the rear-panel digital outputs to a variety of signals present in the instrument to monitor the status of operating conditions or custom Events.	Section 2.5.7
Analog Outputs (option)	Send user-selected parameter readings in the form of user-defined voltage or current loop signals as outputs to a strip chart recorder and/or the data logger.	Section 2.5.8
Instrument	View product and system information, including list of options, if any; view network settings; view/adjust Date and Time settings*; and check for firmware updates when connected to a network that is connected to the Internet. *Time Zone change requires special procedures (Section 5.5).	Section 2.5.9
Comm	View and configure network and serial communications.	Section 2.5.10

2.4.1 HOME PAGE

Figure 2-22 presents an orientation to the main display screen; Figure 2-23 shows that pressing the gas name or its concentration value or a meter below displays a live plot of their respective readings. Section 2.5.6 provides configuration instructions.

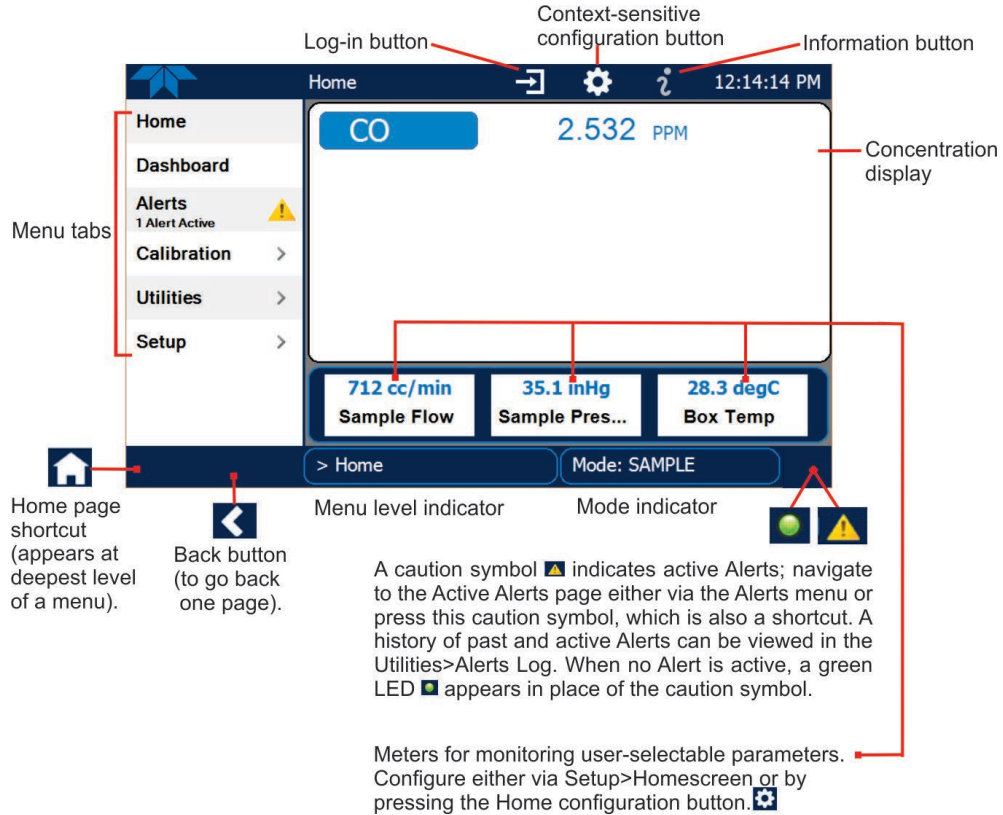
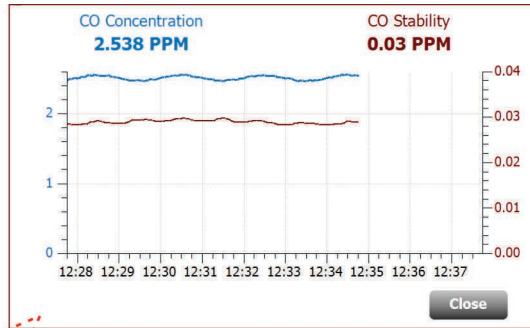

Figure 2-22. User Interface Orientation



N300, N300M

Select either a gas name or its reading to display graph.



Home 12:14:14 PM

Home

Dashboard

Alerts 1 Alert Active

Calibration >

Utilities >

Setup >

CO 2.532 PPM

585.5 CC/M Sample Flow

35.1 inHg Sample Pres...

28.3 degC Box Temp

> Home Mode: SAMPLE

(Change parameters for display in these meters using Home configuration).

Select a meter to display graph.

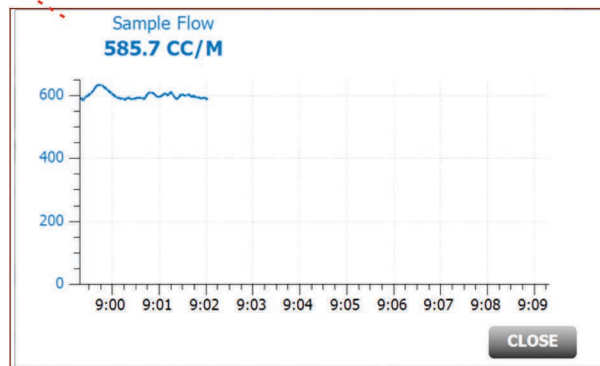
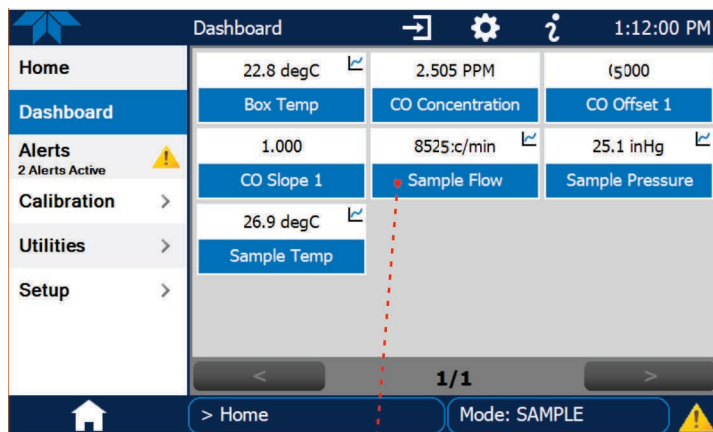

Figure 2-23. Concentration and Stability Graph (top) and Meter Graph (bottom)

2.4.2 DASHBOARD

The Dashboard displays an array of user-selectable parameters and their values (Section 2.5.3 provides configuration instructions). If there is a graphing icon in the upper right corner of a parameter, pressing that parameter displays a live plot of its readings as in Figure 2-24.



Select a graphable parameter in the Dashboard page to view a live plot.

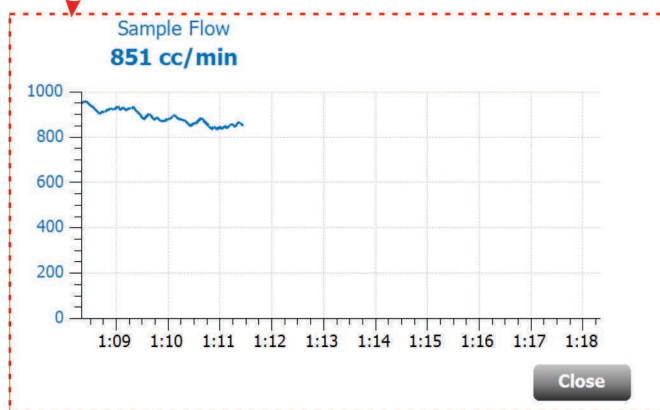

Figure 2-24. Dashboard Page

Common parameters and their descriptions are presented in Table 2-9.

Table 2-9. Common Dashboard Parameters

PARAMETER	UNITS	MEANING
Bench Temp	°C	Optical bench temperature.
Box Temp	°C	The temperature inside the analyzer chassis.
Detector Temp	°C	The operating temperature of the detector. Typical value is <-15°C Fault if temp has exceeded -15°C. If this value is > -15°C, check PHT drive.
CO Offset	-	The overall offset of the instrument as calculated during the last calibration activity.
CO Slope	-	The sensitivity of the instrument as calculated during the last calibration activity.
CO Stability	PPB ³ , PPM UGM ³ , MGM	Standard deviation of CO concentration readings. Data points are recorded every ten seconds using the last 25 data points. This function can be reset to show O ₂ or CO ₂ stability in instruments with those sensor options installed.



N300, N300M

PARAMETER	UNITS	MEANING
IR Measure	MV	The demodulated, peak IR detector output during the measure portion of the GFC Wheel cycle.
IR Reference	MV	The demodulated, peak IR detector output during the reference portion of the GFC Wheel cycle.
MR Ratio	-	(Measure/Reference Ratio) The result of IR Measure divided by IR Reference . This ratio is the primary value used to compute CO concentration. The value displayed is not linearized.
PHT Drive	mV	(Photo-detector temperature control voltage) The drive voltage being supplied to the thermoelectric coolers of the IR photo-detector.
Pump Flow	cm ³ /min	Sample mass flow rate as measured by the flow rate sensor in the sample gas stream.
Sample Pressure	In-Hg-A	The absolute pressure of the Sample gas as measured by a pressure sensor located inside the sample chamber.
Sample Temp	°C	The temperature of the gas inside the sample chamber.
Wheel Temp	°C	GFC Wheel temperature.

2.4.3 ALERTS

Alerts are notifications triggered by specific criteria having been met by either factory-defined conditions (standard and not editable) or user-defined Events (Section 2.5.2). The Active Alerts page shows the status of any active warning conditions or Events that have been triggered.

When Alerts are triggered, a caution symbol appears in both the Alerts menu tab and in the bottom right corner of the software interface, which serves as a shortcut to the Alerts page from any other page. View a list of currently active Alerts by pressing either the Alerts menu on the Home screen or by pressing the Alerts shortcut (Figure 2-25).

While Alerts can be cleared from the Active Alerts page, they remain recorded in the Utilities>Alerts Log menu.

Navigate to the Active Alert page via the Alerts menu on Home screen.

(Also view a list of all active and past Alerts and Events via Utilities>Alerts Log).

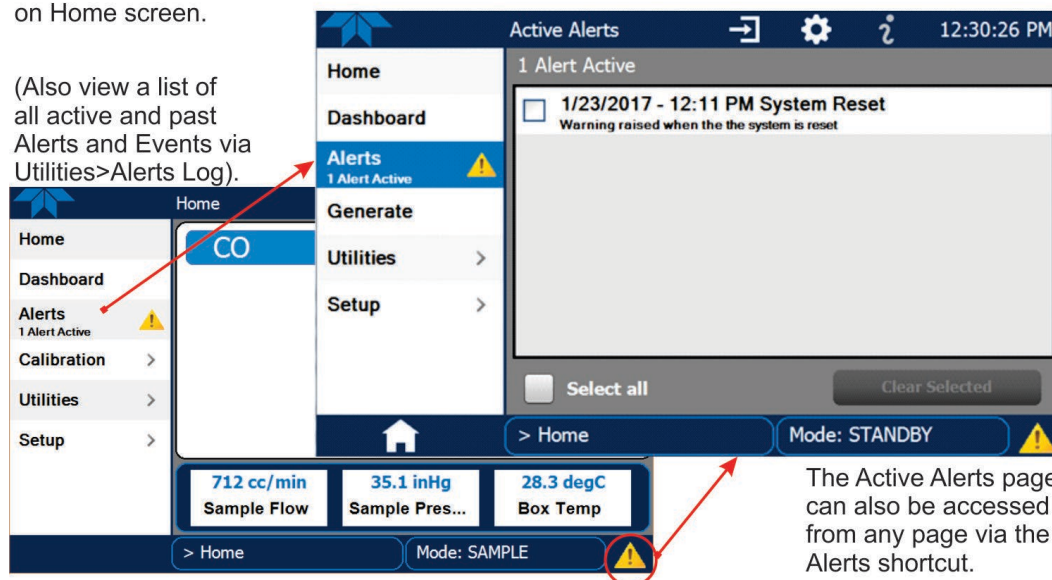

Figure 2-25. Navigating to the Active Alerts Page

Alerts can be configured as either latching (appears in Active Alerts screen when Event is triggered and must be cleared by the user) or non-latching (Active Alerts screen continuously updates based on the Event criteria, clearing on its own). See Section 2.5.2.

To clear Alerts from the Active Alerts page, either check individual boxes to choose specific Alerts, or check the Select All box to choose all Alerts, then press the Clear Selected button.

When all Alerts are cleared, the Alerts menu tab no longer shows the caution symbol, and a green LED replaces the caution symbol in the bottom right corner of the interface (Figure 2-26). However, Alerts can reappear if the conditions causing them are not resolved. For troubleshooting guidance, refer to Section 5.7.

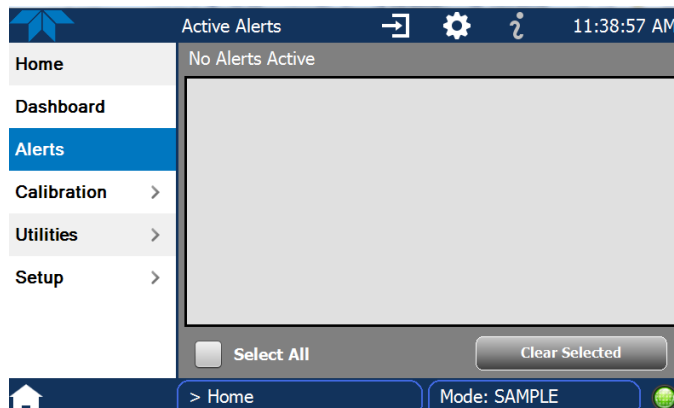

Figure 2-26. Active Alerts Cleared

Alerts and Events remain recorded in the Utilities>Alerts Log (Figure 2-27).

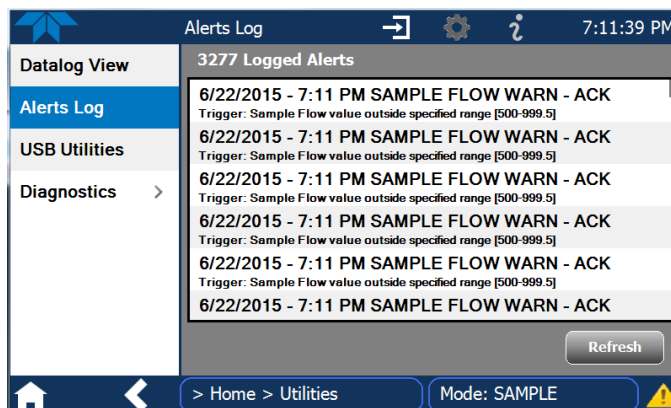

Figure 2-27. Utilities>Alerts Log of Active and Past Alerts and Events

2.4.4 CALIBRATION

The Calibration menu is used for multipoint calibrations as well as calibrations for zero and span with valve options, and for external calibration with valve options installed. Calibration procedures are presented in Section 4.

2.4.5 UTILITIES

The Utilities menu has a variety of functions as described next in Table 2-10.

Table 2-10. Utilities Submenu Descriptions

UTILITIES MENU	DESCRIPTION	
Datalog View	Displays the data logs that were configured via the Setup>Data Logging menu. From this list a log can be selected and filters applied to view the desired data. (For details on setting up and running the Data Logger, see Section 2.5.1).	
Alerts Log	Displays a history of alerts that are triggered by factory-defined and user-defined Events, such as warnings and alarms (See Section 2.5.2 for Events configuration).	
USB Utilities	Serves multiple purposes using a flash drive connected to the instrument's front panel USB port: <ul style="list-style-type: none"> • download data from the instrument's Data Acquisition System (DAS), the Data Logger, to a flash drive (Section 2.5.1.3) • update firmware (Section 5.3) • transfer instrument configuration from/to other same-model instruments (Section 2.6) • download a basic operation functionality report (Section 5.3). 	
Diagnostics	Provides access to various pages that facilitate troubleshooting.	
	Analog Inputs	Measure voltage signals of several analog input parameters. These can be logged in the internal data acquisition system (DAS), by configuring the Data Logger in the Setup>Data Logging menu (Section 2.5.1).
	Analog Outputs (option)	Show the voltage or current signals for the functions selected and configured in the Setup>Analog Outputs option menu (Section 2.5.8). (Section 2.3.1.2 presents the rear panel connections).
	Digital Inputs (option)	Show/change the ON/OFF state of specific, available features with the Digital I/O option.
	Digital Outputs (option)	Show/change the ON/OFF state of user-defined (Setup>Digital Outputs menu, Section 2.5.7). outputs and relays with the Digital I/O option.
	Dark Calibration	Compensate for any voltage levels inherent in the sync/demod circuitry that might affect the CO concentration calculation (Section 4.4.1).
	Pressure Cal	Used for compensating for changes in atmospheric pressure (Section 4.4.2).
	Flow Cal	Used to calibrate the sample gas flow reading with actual flow measured by an external device. (See Section 4.4.3).

2.4.6 SETUP

The Setup menu is used to configure the instrument's various features, functions, and data log. Section 2.5 provides details for the menus under Setup.



2.5 SETUP MENU: FEATURES/FUNCTIONS CONFIGURATION

Use the Setup menu to configure the instrument's software features, to gather information on the instrument's performance, and to configure and access data from the Data Logger, the instrument's internal data acquisition system (DAS). Once the setups are complete, the saved configurations can be downloaded to a USB drive through the Utilities>USB Utilities menu and uploaded to other instruments of the same model (Section 2.6).

2.5.1 SETUP>DATA LOGGING (DATA ACQUISITION SYSTEM, DAS)

The Data Logger can be configured to capture and store user-defined data, which then can be viewed in the Alerts page, if elected, as well as downloaded from the instrument to a USB flash drive or using NumaView™ Remote software for examination and analysis.

Figure 2-28 shows a new log; Figure 2-29 shows a sample existing log, which can be edited or deleted, and Figure 2-30 provides illustrated instructions for setting up a new log, with Sections 2.5.1.1 and 2.5.1.2 providing additional details.

To transfer captured instrument data to a flash drive, see Section 2.5.1.3.

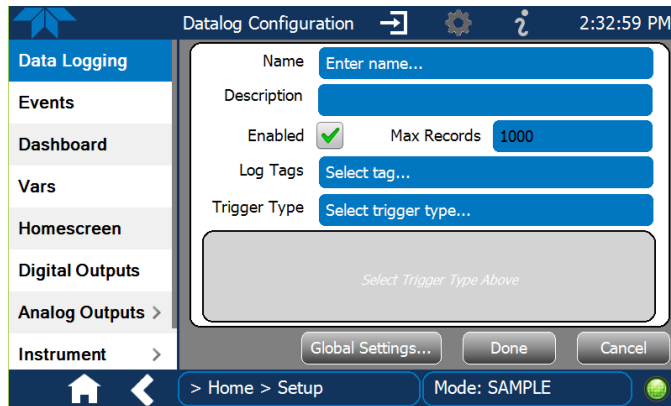

Figure 2-28. Datalog Configuration, New Log Page

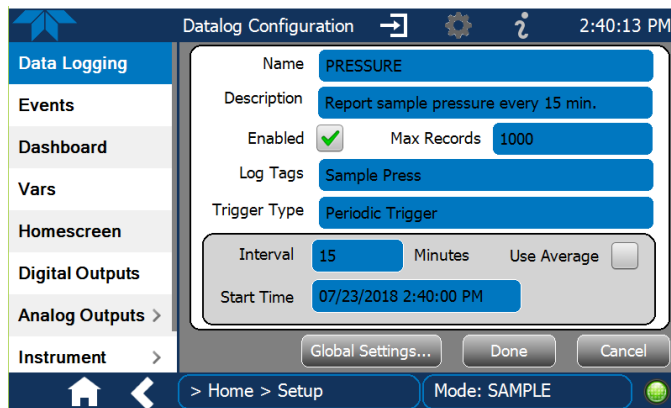
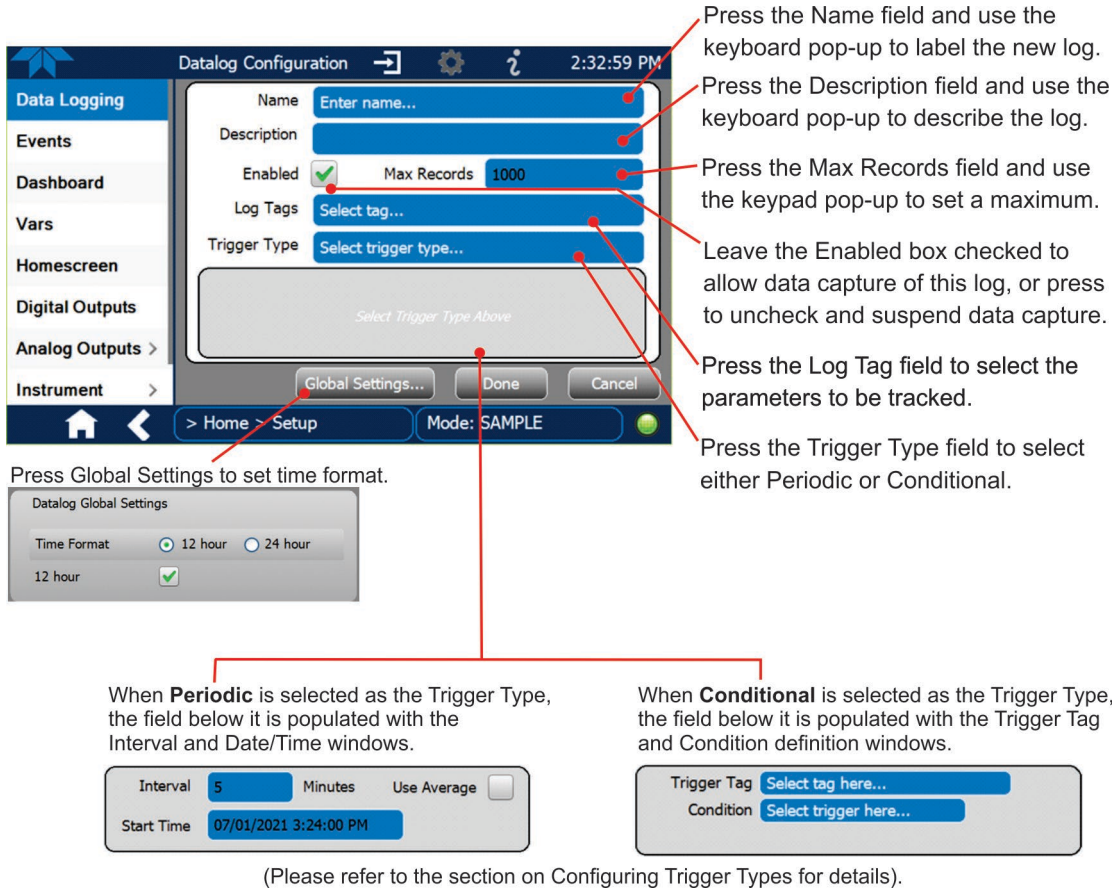

Figure 2-29. Datalog Configuration, Existing Log



Press the Name field and use the keyboard pop-up to label the new log.

Press the Description field and use the keyboard pop-up to describe the log.

Press the Max Records field and use the keypad pop-up to set a maximum.

Leave the Enabled box checked to allow data capture of this log, or press to uncheck and suspend data capture.

Press the Log Tag field to select the parameters to be tracked.

Press the Trigger Type field to select either Periodic or Conditional.

Press Global Settings to set time format.

Datalog Global Settings

Time Format 12 hour 24 hour

12 hour

When **Periodic** is selected as the Trigger Type, the field below it is populated with the Interval and Date/Time windows.

Interval Minutes Use Average

Start Time

When **Conditional** is selected as the Trigger Type, the field below it is populated with the Trigger Tag and Condition definition windows.

Trigger Tag

Condition

(Please refer to the section on Configuring Trigger Types for details).

Figure 2-30. Creating a New Data Log

The parameters available in the list of Log Tags include the names of Events configured in the Events page (Section 2.5.2).



N300, N300M

2.5.1.1 CONFIGURING TRIGGER TYPES: PERIODIC

The Periodic trigger is a timer-based trigger that is used to log data at a specific time interval. Periodic Trigger requires an interval that is set to number of minutes and a start time that is set to date and clock time.

Press the Interval field and use the keypad pop-up to edit the amount of time in minutes ("Use Average" appears with 2 or more minutes) between capturing data for the selected Log Tags.

Press the Start Time field and use the Time and Date pop-ups to select the time and the date to start capturing data for the parameters that were selected in the Log Tags field.

(toggle)

Figure 2-31. Datalog Periodic Trigger Configuration

2.5.1.2 CONFIGURING TRIGGER TYPES: CONDITIONAL

Conditional Trigger tracks/records data for user-selected parameters that meet specified conditions.

Press the Trigger Tag field and select a parameter to be tracked/logged. A default Condition associated with the selected Tag will populate the Condition field.

Press the Condition field to select a different choice from the condition list.

Either the Threshold field appears, or the Low and High fields appear if a condition requires either a threshold value or range values. Press a Value... field and use the keypad.

(Also includes True/False and Enabled/Disabled)

Figure 2-32. Datalog - Conditional Trigger Configuration

2.5.1.3 DOWNLOADING DAS (DATA ACQUISITION SYSTEM) DATA

To download DAS data collected by the Data Logger from the instrument to a flash drive, navigate to the Utilities>USB Utilities>DAS Download menu.

1. Insert a flash drive into a front panel USB port and wait for the Status field to indicate that the drive has been detected; available buttons will be enabled.

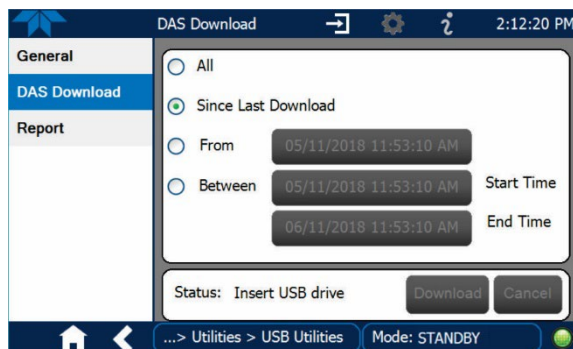

Figure 2-33. DAS Download Page

2. Select all or define a period from which to download the collected data.
3. Press the Download button, and when complete, as indicated in the Status field, press the Done button (changed from “Cancel”) and remove the flash drive.

2.5.2 SETUP>EVENTS

Events are occurrences that relate to any operating function, and are used to define the conditions that can be set to trigger Alerts (Section 2.4.3). Events can provide diagnostic information about the instrument, typically referred to as “Warnings”, or they can provide other information on instrument functionality, such as concentration alarms. Some Events are standard and not editable while others are user-configurable, described here. Existing Events are listed in the Events page (Figure 2-34) under the Setup menu.

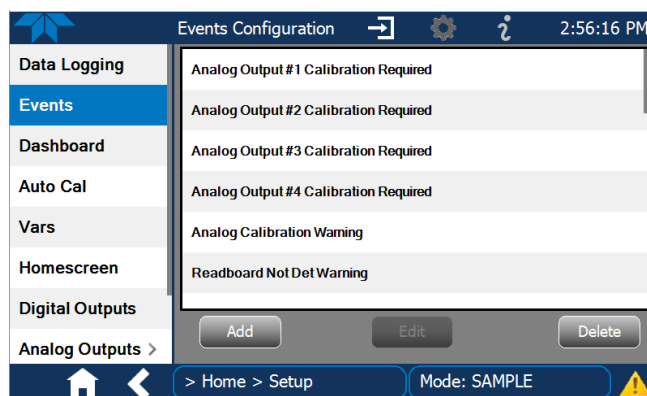

Figure 2-34. Events List

Access the Events Configuration page either from the Active Alerts page (Alerts Menu) by pressing the configuration button, or through the Home>Setup>Events menu

(Figure 2-34). Press ADD to create a new Event (refer to Figure 2-35 for details), or select an existing Event to either Edit or Delete it (Figure 2-37).

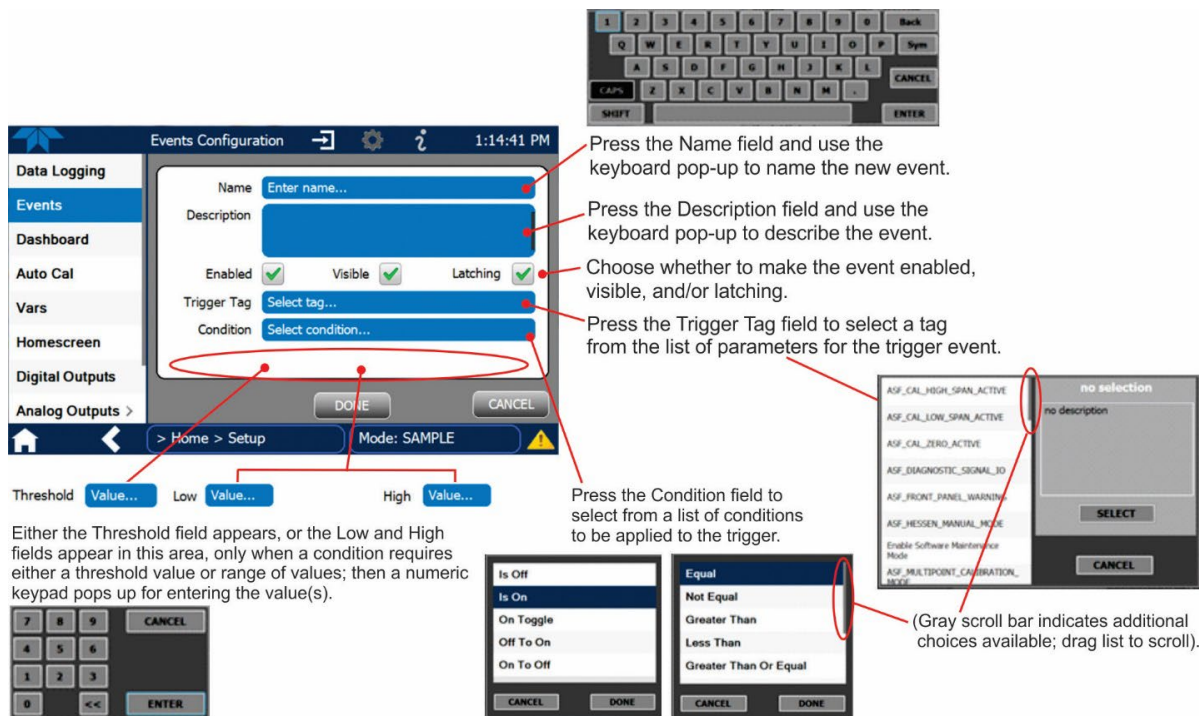

Figure 2-35. Event Configuration

- **Enabled** allows the choice of whether to track and record the Event (uncheck this box to “turn off” or deactivate the Event without deleting it). An Event must be enabled in order to use the Visible and the Latching options.
- **Visible** allows the choice of whether or not to display the Event in the Alerts page when it is triggered (it will still be recorded and can be viewed in the Utilities>Alerts Log). To use this option, the Event must be enabled.
- **Latching** allows the choice of whether or not to keep an Event visible even if the conditions that triggered it were to correct themselves. (Latching requires that the user interact with the Active Alerts screen to manually clear the Alert and internal Event state. Non-latching allows the entry in the Active Alerts screen and the internal Event state to continuously update based on the Event criteria, requiring no user interaction to clear the Alert or Event state).

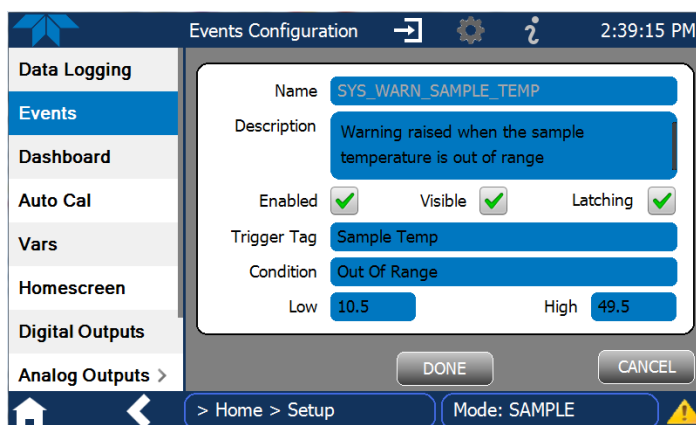

Figure 2-36. Configured Event Sample



2.5.2.1 EDITING OR DELETING EVENTS

Select an Event from the list (Figure 2-34) and press the Edit button to view or edit the details (Figure 2-36), or press the Delete button to delete the Event.

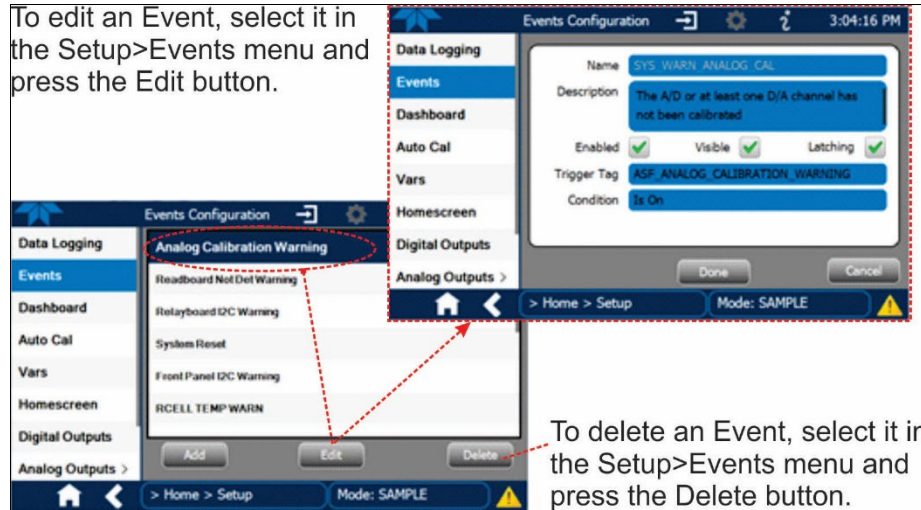
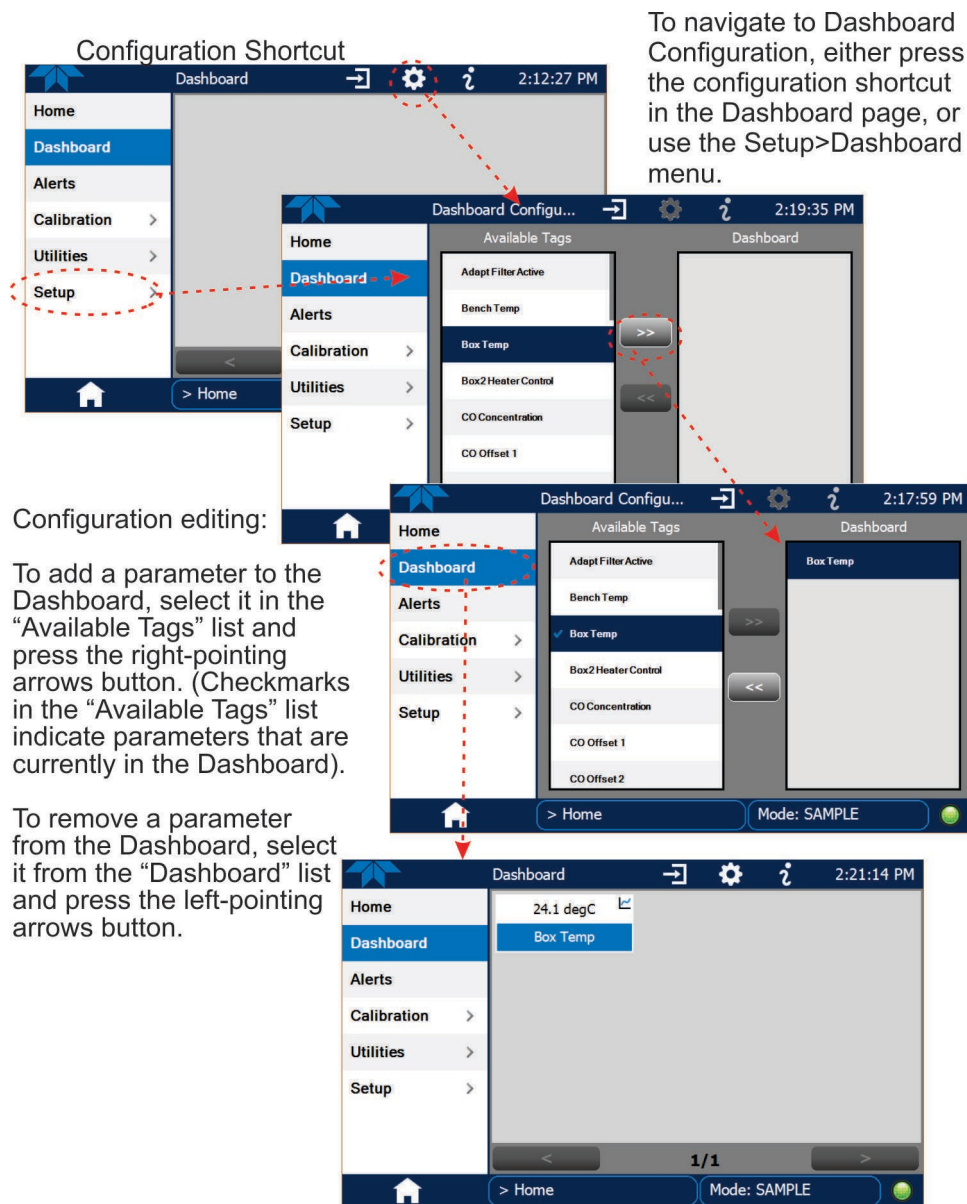

Figure 2-37. Edit or Delete an Event

2.5.2.2 USING EVENTS AS TRIGGERS FOR DATA LOGGING

Events can also be used to create customized triggers for data logging functions. The name entered in the Name field of the Events Configuration page will appear in the list of Log Tags of the Datalog Configuration page. The Data Logger is presented in Section 2.5.1.

2.5.3 SETUP>DASHBOARD



To navigate to Dashboard Configuration, either press the configuration shortcut in the Dashboard page, or use the Setup>Dashboard menu.

Configuration editing:

To add a parameter to the Dashboard, select it in the "Available Tags" list and press the right-pointing arrows button. (Checkmarks in the "Available Tags" list indicate parameters that are currently in the Dashboard).

To remove a parameter from the Dashboard, select it from the "Dashboard" list and press the left-pointing arrows button.

Figure 2-38. Dashboard Display and Configuration

2.5.4 SETUP>AUTOCAL (WITH VALVE OPTION)

Auto Cal, automatic zero/span calibration check, is available with installed valve options (see Sections 2.3.2 and 4.2.2.2).

2.5.5 SETUP>VARS

Vars are software variables that define operational parameters automatically set by the instrument's firmware and are user-adjustable through this menu. Access the menu to see the list of variables; select a variable to view its description; touch the Edit button to change its setting(s).



N300, N300M

Table 2-11. List of Variables with Descriptions

VARIABLE	DESCRIPTION
NOTE: This list includes several of the more common Vars; selecting any Var in the NumaView™ software interface will display its description in the information field to its right. Depending on configuration, some, all, or more of these variables appear in your instrument's Vars menu.	
Conc Precision (or PRIGAS/SECGAS Precision)	Sets the number of significant digits to the right of the decimal point display of concentration and stability values. ("PRIGAS" = primary gas with two or more other gases; "SECGAS" = secondary gas)
Daylight Savings Enable	Enable or disable Daylight Savings Time (also see Setup>Instrument>Date/Time Settings)
Dilution Factor Option	<p>Sets the instrument to compensate for diluted sample gas, such as in continuous emission monitoring (CEM) where the quality of gas in a smoke stack is being tested and the sampling method used to remove the gas from the stack dilutes the gas. Once the degree of dilution is known, this feature allows the user to add an appropriate scaling factor to the analyzer's concentration calculations so that the undiluted values for measurement range and concentration are shown on the instrument's front panel display and reported via the instrument's various outputs.</p> <p>To add the appropriate scaling factor:</p> <ol style="list-style-type: none"> 1. First, check that the analyzer's measurement units are the same as those used for determining the amount of dilution. (The analyzer's measurement units can be changed in the Setup>Vars>User Units menu). 2. Then, set the Dilution Factor Var as a gain to reflect the dilution ratio that was determined. For example, if the amount of dilution is found to be 20 parts diluent to 1 part sample gas (a dilution ratio of 20:1), the gain to be input into the Setup Vars Dilution Factor should be 20 (100:1 is common). 3. Calibrate the analyzer; ensure that the calibration span gas is either supplied through the same dilution system as the sample gas or has an appropriately lower actual concentration (a concentration that matches the diluted gas concentration prior to having input the Dilution Factor).
[Enable] Software Maintenance Mode	Set instrument to continue sampling, while ignoring calibration, diagnostic, and reset instrument commands.
Instrument ID	Set unique identifier number for the instrument when it is connected with other instruments on the same Ethernet LAN, or when applying MODBUS protocol. (Setup>Vars>Instrument ID)
Modbus Units	<p>If this Var is changed, the instrument must be restarted. LEGACY units is for Modbus registers to be in PPB; where DYNAMIC units is for Modbus registers to be user selected.</p> <p>NOTE that if you change the analyzer's Modbus Units to "DYNAMIC" it is recommended that you confirm your data logger settings since some data loggers have settings to convert PPB units to PPM.</p>
Range Mode	Controls range mode, single (SNGL) or dual (DUAL).
System Hours	Total system runtime hours
TPC Enable	Enables or disables the Temperature and Pressure Compensation (TPC) feature (For information on TPC, see Section 6.6.4).
User Units	Change the concentration units of measure.



2.5.6 SETUP>HOMESCREEN

To select a parameter (“tag”) for display in each of the three meters at the bottom of the Home page, navigate to the Homescreen configuration page through either the Setup>Homescreen menu or from Home page using the configuration icon (Figure 2-39).

From Home page, either navigate to Setup>Homescreen or select configuration button.



Figure 2-39. Homescreen Configuration

An orientation to the Homescreen was presented in Section 2.4.1, including Figure 2-22 and Figure 2-23.



2.5.7 SETUP>DIGITAL OUTPUTS (OPTION)

Specify the function of each digital output (connected through the rear panel Digital I/O connector) by mapping the output to a selection of “Signals” present in the instrument. Create custom “Signals” in the Setup>Events menu (Section 2.5.2). The three Relays can also be connected and functions assigned.

To map Digital Outputs to Signals, select a pin in the Outputs list (DO1 thru DO5), then make a selection from the Signals list and press the Map button; if/as needed, change the polarity by pressing the Polarity button. Save any changes by pressing the Apply button, or discard the changes by pressing the Home or the back button (a pop-up provides a warning that the changes will be lost, and will prompt for confirmation to apply changes or not). Map the Digital Relays in the same manner.

For testing only, navigate to the Utilities>Diagnostics>Digital Outputs menu to change the state (ON/OFF) of individual digital outputs.

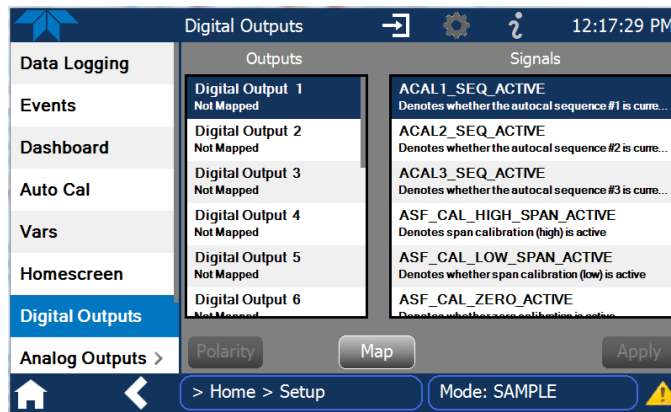

Figure 2-40. Digital Outputs Setup

2.5.8 SETUP>ANALOG OUTPUTS (OPTION)

Map the user-configurable Analog Outputs for either voltage output (Figure 2-41) or current output (Figure 2-42) to any of a wide variety of “Signals” present in the instrument and customize their respective configurations.

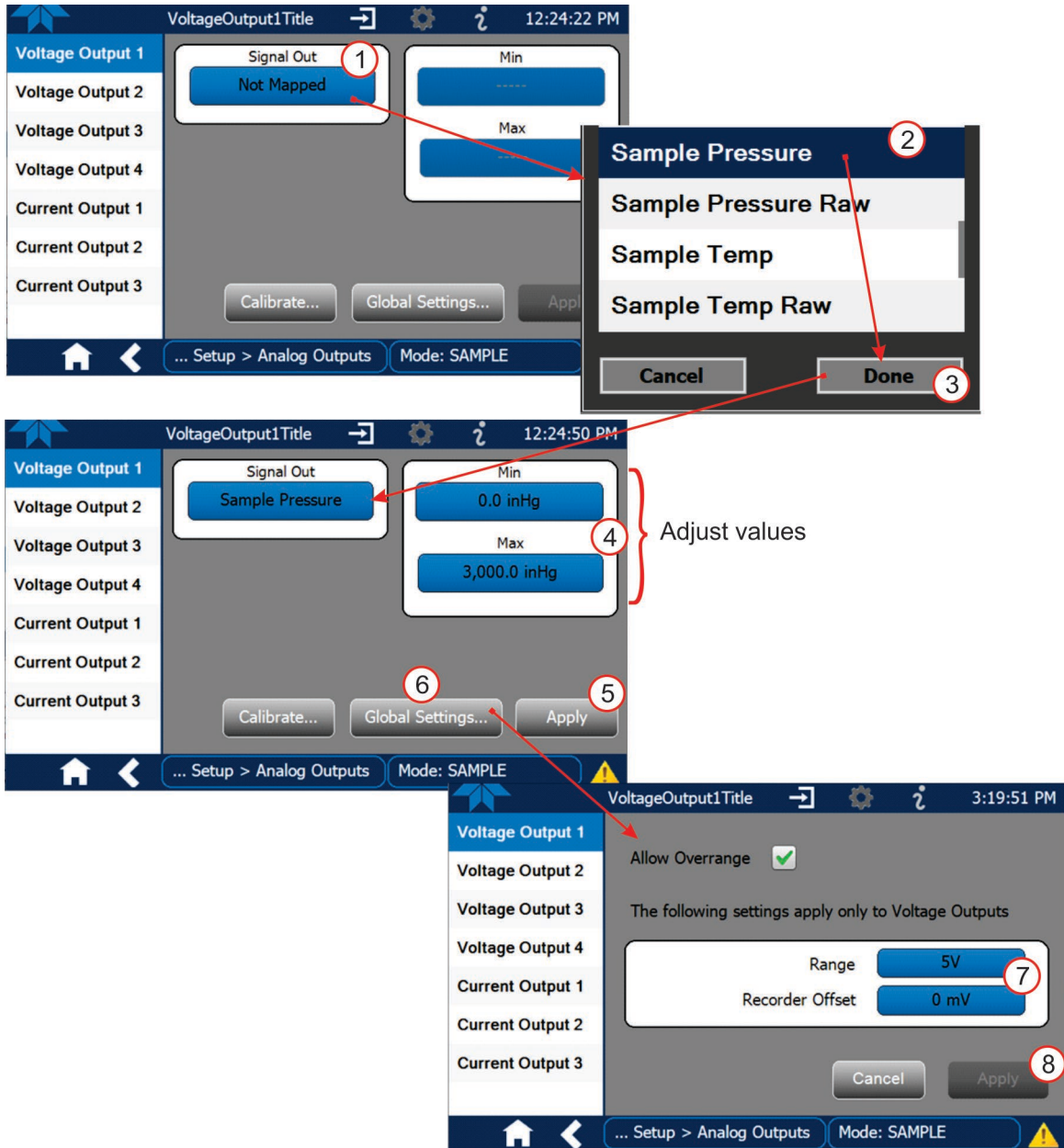

Figure 2-41. Analog Output Configuration for Voltage Output, Example

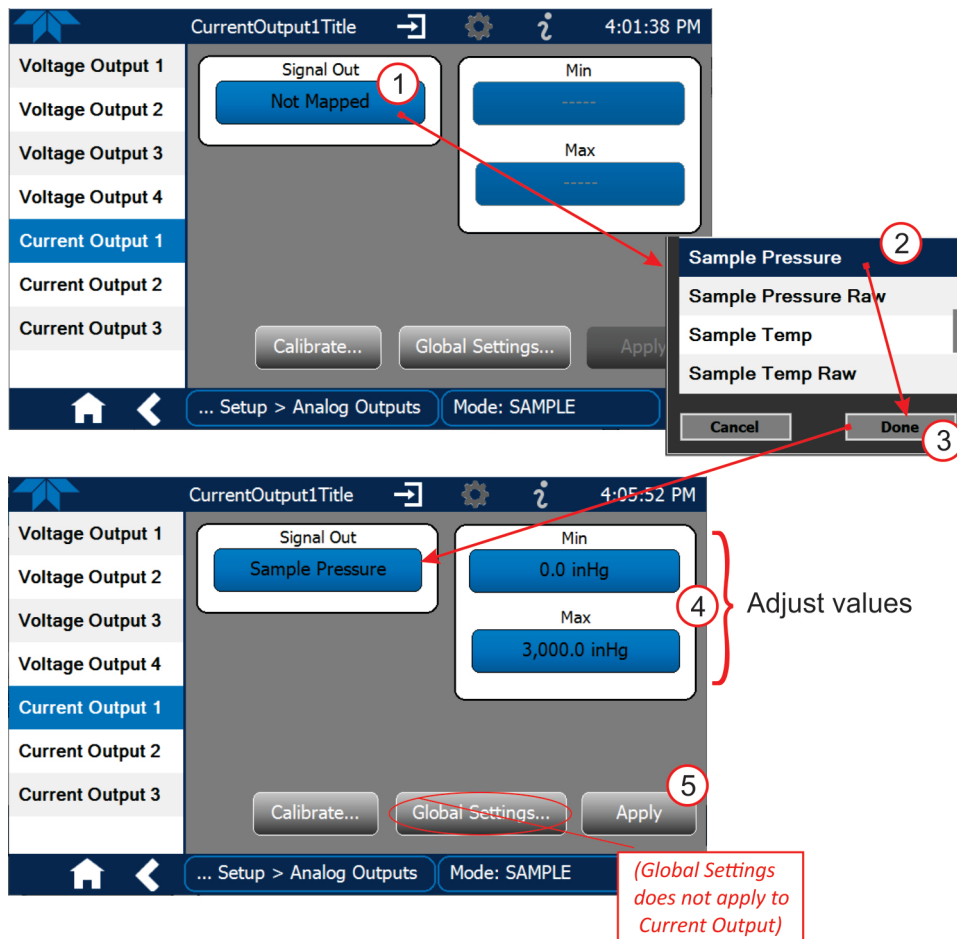

Figure 2-42. Analog Output Configuration for Current Output, Example

Refer to Figure 2-41 (Voltage output) or Figure 2-42 (Current output), and to Table 2-12 for the following:

1. Signal Out: select a Signal for the output (typically the gas concentration).
2. Min/Max: edit Min and Max fields with realistic values for the selected Signal.
3. Global Settings:
 - For Voltage output, select a Range, and in the Recorder Offset field, add a zero offset for recording slightly negative readings from noise around the zero point. Either check “Allow Overrange” to allow a $\pm 5\%$ over-range, or uncheck to disable over-range if the recording device is sensitive to excess voltage and assign a maximum voltage.
 - For Current output, Global Settings does not apply.
4. After completing the configurations, press the (Apply or Accept) button.
5. To calibrate, press the Calibrate button to see the reading, and use the buttons in the Manual Adjust field to make incremental adjustments as needed, noting the range and the minimum/maximum outputs shown in (Table 2-12).
 - For Current output, press the +100 button several times to get the setting close to 4mA.
6. Press the Accept button when adjustment reached.

Table 2-12. Analog Output Voltage/Current Range

RANGE ¹	RANGE SPAN	MINIMUM OUTPUT	MAXIMUM OUTPUT
5V	0-5 VDC	-1 VDC	6 VDC
10V	0-10 VDC	-2 VDC	12 VDC
Current	4-20 mA	3 mA	21 mA

¹ Each range is usable from -5% to +5% of the rated span.

For manual calibration adjustments, see Section 2.5.8.1 for voltage and Section 2.5.8.2 for current.



Figure 2-43. Analog Output Calibration, Voltage or Current



N300, N300M

2.5.8.1 MANUAL CALIBRATION ADJUSTMENT OF VOLTAGE RANGE ANALOG OUTPUTS

To manually calibrate the voltage outputs, use a voltmeter (Figure 2-44) connected across the Voltage output terminals (see Figure 2-6 for pin assignments and diagram of the analog output connector) and changing the output signal level in the Manual Adjust field of the Analog Outputs Voltage Output Calibration screen (Figure 2-43).

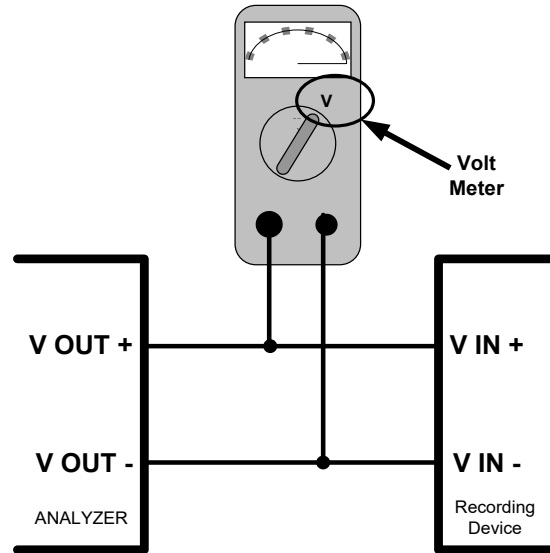

Figure 2-44. Setup for Checking / Calibrating DCV Analog Output Signal Levels

2.5.8.2 MANUAL CALIBRATION ADJUSTMENT OF CURRENT RANGE ANALOG OUTPUTS

To manually calibrate the current outputs, use an ampmeter (Figure 2-45) connected across the Current output terminals (see Figure 2-6 for pin assignments and diagram of the analog output connector) and changing the output signal level in the Manual Adjust field of the Analog Outputs Current Output Calibration screen (Figure 2-43). While the software allows this adjustment to be made in 100, 10 or 1 count increments, the adjustments here would need several presses of the +100 button to arrive at a realistic starting point for 4mA.



CAUTION!

Do not exceed 60 V peak voltage between current loop outputs and instrument ground.

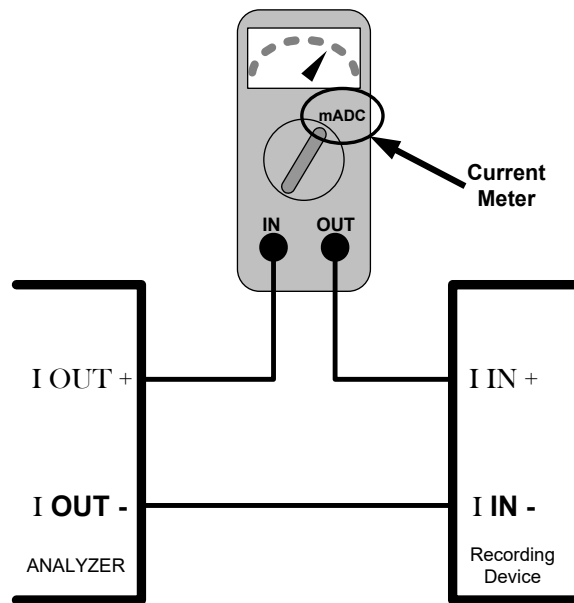

Figure 2-45. Setup for Checking / Calibration Current Output Signal Levels

2.5.9 SETUP>INSTRUMENT

As presented in Table 2-13, view product and system information and network settings, edit network settings, and perform certain maintenance tasks.

Table 2-13. Setup>Instrument Menu

MENU	DESCRIPTION
Product Info	View Model, Part, and Serial Numbers and Package and Driver Versions, and options information.
System Info	View Windows and RAM information.
Network Settings	View the network settings (configurable through the Setup>Comm>Network Settings menu).
Module Info	Provides part and revision numbers of the modules that are installed
Date/Time Settings	Adjust date, hour, and minutes, select a time zone*, and set the system clock to automatically adjust for Daylight Savings Time or not. (Also see Setup>Vars>Daylight Savings Enable). *Time Zone change requires a special procedure; see Maintenance Section 5.5.
NTP Time Settings	Configure Network Time Protocol settings for clock synchronization.
Language	Select an available language.
Remote Update	When an instrument is connected to a network that is connected to the Internet, follow the instructions on this Remote Update page to check for and activate software/firmware updates. (Also refer to Section 5.3).

2.5.10 SETUP>COMM (COMMUNICATIONS)

This menu is for configuring the various communications interfaces.

2.5.10.1 COM2

Configure the instrument's COM port to operate in modes listed in Table 2-14.

Table 2-14. Com Port Configuration

MODE	DESCRIPTION
Baud Rate	Set the baud rate.
Command Prompt Display	Enable/disable a command prompt to be displayed when in terminal mode.
Data Bits	Set the data bits to 7 or 8 (typically set in conjunction with Parity and Stop bits).
Echo and Line Editing	Enable/disable character echoing and line editing.
Handshaking Mode	Choose SOFTWARE handshaking for data flow control (do NOT use SOFTWARE handshaking mode when using MODBUS RTU for Protocol mode; select only HARDWARE or OFF for MODBUS RTU), or HARDWARE for CTS/RTS style hardwired transmission handshaking. (This style of data transmission handshaking is commonly used with modems or terminal emulation protocols). Or choose to turn OFF handshaking.
Hardware Error Checking	Enable/disable hardware error checking.
Hardware FIFO	Enable/disable the hardware First In – First Out (FIFO) for improving data transfer rate for that COM port.
Modem Connection	Select either a modem connection or a direct cable connection.
Modem Init String	Input an initialization string to enable the modem to communicate.
Parity	Select odd, or even, or no parity (typically set in conjunction with Data Bits and Stop Bits).
Protocol	Select among the communications protocols: MODBUS RTU, or MODBUS ASCII.(Section 3.1.1), Hessen (Section 3.1.2), or REST (Section 3.1.3). If selecting a MODBUS protocol, see Handshaking Mode, this table; MODBUS Registers are presented in Appendix A, this manual. Also see www.modbus.org .
Quiet Mode	Enable/disable Quiet mode, which suppresses any feedback from the analyzer (such as warning messages) to the remote device and is typically used when the port is communicating with a computer program where such intermittent messages might cause communication problems. Such feedback is still available, but a command must be issued to receive them.
Security	Enable/disable the requirement for a password for this serial port to respond. The only command that is active is the request-for-help command (? CR).
Stop bits	Select either 0 or 1 stop bit (typically set in conjunction with Parity and Data bits).

2.5.10.2 TCP PORT2

This menu is configured with the port number for MODBUS (Section 3.1.1).

2.5.10.3 NETWORK SETTINGS

The Setup>Comm>Network Settings menu is for Ethernet configuration. The address settings default to automatic configuration by Dynamic Host Configuration Protocol (DHCP). Most users will want to configure the instrument with a static IP address: click the Static radio button to manually assign a static IP address (consult your network administrator, and see Table 2-15 for information).

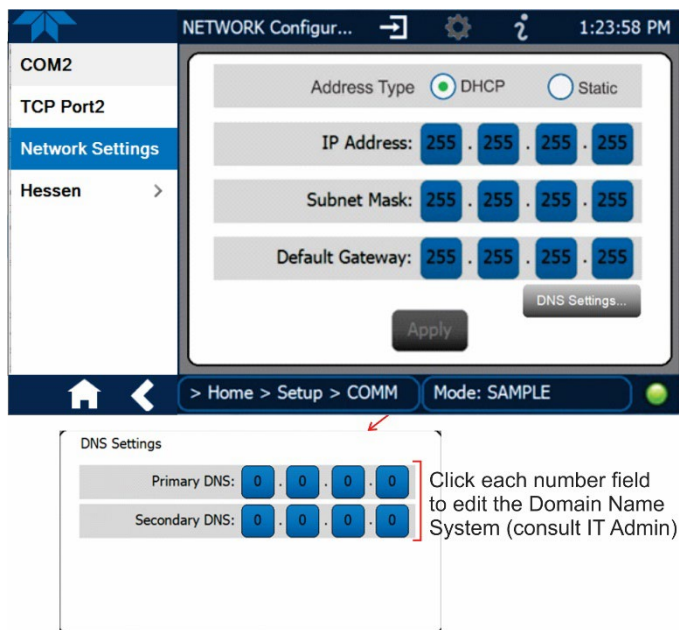

Figure 2-46. Communications Configuration, Network Settings

Table 2-15. LAN/Ethernet Configuration Properties

PROPERTY	DESCRIPTION
IP address	A string of four numbers, 1 to 3 digits each (e.g. 192.168.76.55.) is the internet protocol address of the instrument itself.
Subnet Mask	A string of four numbers, 1 to 3 digits each (e.g. 255.255.252.0) number that masks an IP address, and divides the IP address into network address and host address and identifies the LAN to which the device is connected. All addressable devices and computers on a LAN must have the same subnet mask. Any transmissions sent to devices with different subnets are assumed to be outside of the LAN and are routed through the gateway computer onto the Internet.
Default Gateway	A string of numbers very similar to the Instrument IP address (e.g. 192.168.76.1.) that is the address of the computer used by your LAN and serves as a router to access the Internet or another network.

2.5.10.4 HESSEN

Configure Hessen Settings and Gas List (see Section 3.1.2).



2.6 TRANSFERRING CONFIGURATION TO OTHER INSTRUMENTS

Once an instrument is configured, the same configuration can be copied to other instruments of the same Model. This encompasses essentially anything the user can configure and does not apply to instrument-specific settings such as those that are configured at the factory for calibration.

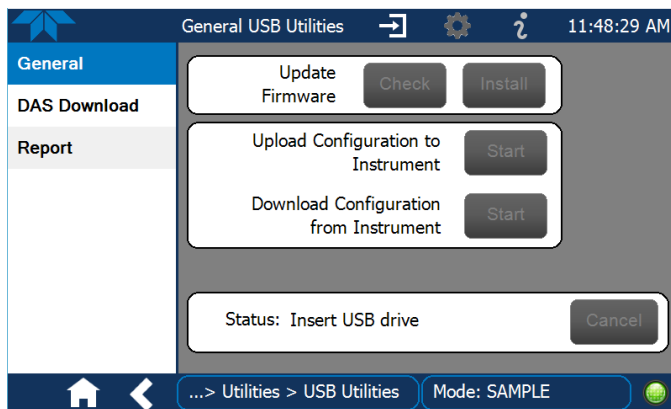

Figure 2-47. Configuration Transfer

1. In the source instrument, go to the Home>Utilities>USB Utilities>General page.
2. Insert a flash drive into either of the two front panel USB ports.
3. When the Status field indicates that the USB drive has been detected, press the “Download Configuration from Instrument” Start button.
4. When the Status field indicates that the download is complete, remove the flash drive.
5. In the target instrument, go to the Home>Utilities>USB Utilities>General page.
6. Insert a flash drive into either of the two front panel USB ports.
7. When the Status field indicates that the USB drive has been detected, press the “Upload Configuration to Instrument” Start button.
8. When the Status field indicates that the upload is complete, remove the flash drive.



3. COMMUNICATIONS AND REMOTE OPERATION

This instrument's rear panel connections include an Ethernet port and a serial communications port. Connection instructions were provided in Section 2.3.1.4. Configuration information was provided in Section 2.5.10.

Data acquisition is set up through the Data Logger (Section 2.5.1).

3.1 SERIAL COMMUNICATION

The rear panel COM port operates on the RS-232 protocol (default configuration is DCE RS-232), or it can be configured for DTE RS-232 operation (more common for PLCs) (Section 2.3.1.4).

Referring to Table 2-14, use the SETUP>COMM menu to view/edit the communications settings for the COM port.

3.1.1 MODBUS

MODBUS communications can be configured through the Setup>Comm>COM2 menu for transmission over Ethernet (Section 3.1.3) or serial communications.

1. Make the appropriate cable connections between the instrument and a PC.
2. Check the instrument's Modbus Units selection in the Setup>Vars menu and edit if needed.
3. Select the communication protocol for either MODBUS RTU or MODBUS ASCII transmission mode.

Important

When using MODBUS RTU, ensure that the Handshaking Mode is set to either Hardware or OFF. Do NOT set it to Software.

4. Set other parameters as needed (see descriptions in Table 2-14).
5. Press the Accept button to apply the settings.

The Setup>Comm>TCP Port2 is set to 502 for MODBUS by default.

See Appendix A for MODBUS Registers.



3.1.2 HESSEN

Hessen protocol is supported through serial communications. The Hessen protocol is not strictly defined; therefore, while Teledyne API's application is completely compatible with the protocol itself, it may be different from implementations by other companies. Configure the COM2 port for Hessen protocol through the Setup>Comm>COM2 menu: select COM2 Protocol and press Edit to select HESSEN, then press Accept.

Hessen configuration includes settings for alarms, version, response mode, status flags and gas list. Locate the alarms in the Hessen Settings list (Setup>Comm>Hessen>Hessen Settings) and edit as desired.

HESSEN PROTOCOL RESPONSE MODE

Set the response mode under Hessen Response Mode, referring to Table 3-1 for descriptions.

Table 3-1. Teledyne API's Hessen Protocol Response Modes

MODE ID	MODE DESCRIPTION
CMD	This is the default setting. Responses from the instrument are encoded as the traditional command format. Style and format of responses depend on exact coding of the initiating command.
BCC	Responses from the instrument are always delimited with <STX> (at the beginning of the response, <ETX> (at the end of the response followed by a 2 digit Block Check Code (checksum), regardless of the command encoding.
TEXT	Responses from the instrument are always delimited with <CR> at the beginning and the end of the string, regardless of the command encoding.

HESSEN VARIATION

For the Hessen Variation setting, there are two versions.

- TYPE 1 is the original implementation.
- TYPE 2 has more flexibility when operating with instruments that can measure more than one type of gas. For more specific information about the difference between the two versions, download the *Manual Addendum for Hessen Protocol* from the Teledyne API's web site: <http://www.teledyne-api.com/manuals/>.

HESSEN STATUS FLAGS

Locate the various status flags in the Hessen Settings list and edit as needed. They are listed by status flag name with their default bit assignments. (Those with unassigned flags are listed as "0x0000").

- The status bits are included in the instrument's responses to inform the host computer of its condition. Each bit can be assigned to one operational and warning message flag.
- It is possible to assign more than one flag to the same Hessen status bit. This allows the grouping of similar flags, such as all temperature warnings, under the same status bit.
- Assigning conflicting flags to the same bit will cause each status bit to be triggered if any of the assigned flags is active.

HESSEN LIST

Table 3-2 describes the Hessen List (Setup>Comm>Hessen menu).

Table 3-2. Hessen List Configuration Summary

ITEM	DEFINITION
Parameter	gas or non-gas parameter: either Add new or Edit existing.
Range	concentration range to be reported (when Reported box is checked)
0	currently active range
1	only when range 1 or low range is active
2	only when range 2 or high range is active
3	not applicable
Id	unique identification for selected parameter
310	typically designated for CO
Reported	check to report when polled by the Hessen network

3.1.3 REST

The REST protocol can be used to collect data, change parameters, extract data logs, poll groups of parameter values, and trigger calibration functions.

The user needs to be familiar with REST principles and underlying network technologies. The REST API service is on port 8180, using HTTP verbs (GET, PUT) and REST Resources in JSON format. Tag names and command strings are case sensitive. The Resources are defined in Table 3-3.

The Teledyne API REST guide is a tutorial in the form of Service Note 22-002, accessible on our website under this product page's Downloads tab.

Important

EXTERNAL DATALOGGER BEST FOR REST PROTOCOL
Frequent polling of the instrument's datalogger with REST can slow not only its software routines and tasks, but also the response to the external datalogger polling request.
We recommend polling the live Tag values directly for external datalogger use with REST protocol.

Table 3-3. REST Resource Descriptions

RESOURCE	DESCRIPTION	OPERATION
Tag	Maps to an instrument tag, allowing direct access to parameter properties/attributes	Read/Write (GET/PUT)
Tag.value	Maps to an instrument tag value separately from its properties for direct/fast access due to dynamic characteristics	Read/Write (GET/PUT)
Tag-list	Queries for instrument's available tags and their properties; query can be filtered for specific tag group	Read only (GET)
Tag-list.value	Retrieves specified group of tag values as a batch; groups include: PRIGAS, LOG, TRIG, AOUTMAP, HIST, TRACK_ALL_UPDATES	Read/Write (GET/PUT)
Datalog-list	Retrieves list of the instrument's available data logs	Read only (GET)
Datalog	Retrieves specified data log, based on a defined page number and number of records per page, or on a defined time range that includes start & end date, hour (24-hr format), minute, and seconds (where blank = default, no seconds)	Read only (GET)



3.2 ETHERNET

When using the Ethernet interface, the analyzer can be connected to any Ethernet network via low-cost network hubs, switches or routers. The interface operates as a standard TCP/IP device on port 3000. This allows a remote computer to connect through the network to the analyzer using NumaView™ Remote, terminal emulators or other programs.

The Ethernet connector has two LEDs that are on the connector itself, indicating its current operating status.

Table 3-4. Ethernet Status Indicators

LED	FUNCTION
green (link)	On when connection to the LAN is valid.
amber (activity)	Flickers during any activity on the LAN.

The analyzer is shipped with DHCP enabled by default. This allows the instrument to be connected to a network or router with a DHCP server; however, it should be configured with a Static IP address as soon as practical. See Section 2.5.10.3 for configuration details.

For MODBUS communications configuration, see Section 3.1.1.

3.3 NUMAVIEW™ REMOTE

For remote operation and data capture through an Ethernet connection, please refer to the NumaView™ Remote Software User Guide, PN 08492, available on our website.



4. CALIBRATION

This Section provides important pre-calibration information, calibration and check procedures, and how to evaluate the quality of each calibration.

4.1 IMPORTANT PRECALIBRATION INFORMATION

Note

A one-hour warm-up period is recommended prior to calibrating the analyzer.

4.1.1 CALIBRATION REQUIREMENTS

Calibration of the analyzer requires specific equipment and supplies. These include, but are not limited to, the following:

- Zero-air source
- Span gas source
- Gas lines - All Gas lines should be PTFE (Teflon), FEP, glass, stainless steel or brass
- Optionally, a recording device such as a strip-chart recorder and/or data logger. (For electronic documentation, the internal data acquisition system DAS can be used by configuring the Data Logger through the Setup>Data Logging menu, Section 2.5.1).
- Traceability Standards

4.1.2 ZERO AIR

Zero air or zero calibration gas is defined as a gas that is similar in chemical composition to the measured medium but without the gas to be measured by the analyzer.

For the N300/N300M zero air should contain less than 25 ppb of CO and other major interfering gases and should have a dew point of -5°C or less.

If your application is not a measurement in ambient air, the zero calibration gas should be matched to the composition of the gas being measured.

- Pure nitrogen (N₂) can be used as a zero gas for applications where CO is measured in nitrogen.
- If your analyzer is equipped with an external zero air scrubber option, it is capable of creating zero air from ambient air.

For analyzers without the zero air scrubber, a zero air generator such as from the TAPI 700-Series can be used. Please visit the company website for more information.



4.1.3 CALIBRATION (SPAN) GAS

Span Gas is a gas specifically mixed to match the chemical composition of the type of gas being measured at near full scale of the desired measurement range and should be certified traceable to NIST Standard Reference Material (SRM). It is recommended that the span gas used have a concentration equal to 80-90% of the full measurement range.

If Span Gas is sourced directly from a calibrated, pressurized bottle, use the exact concentration value printed on the bottle.

For oxygen measurements using the optional O₂ sensor, we recommend a reference gas of 21% O₂ in N₂.

- For quick checks, ambient air can be used at an assumed concentration of 20.8%.
- Generally, O₂ concentration in dry, ambient air varies by less than 1%.

4.1.4 INTERFERENTS

It should be noted that the gas filter correlation method for detecting CO is subject to interference from a number of other gases that absorb IR in a similar fashion to CO. Most notable of these are water vapor, CO₂, N₂O (nitrous oxide) and CH₄ (methane). The N300/N300M has been successfully tested for its ability to reject interference from of these sources, however high concentrations of these gases can interfere with the instrument's ability to make low-level CO measurements.

For a more detailed discussion of this topic, see Section 6.2.1.4.

4.1.5 DILUTION RATIO OPTION SOFTWARE SET UP

If your application involves diluting the sample gas before it enters the analyzer, and the Dilution Ratio Option is enabled:

1. Set the appropriate units of measure (Setup>Vars>User Units).
2. Select the reporting range mode (Setup>Vars>Range Mode [Single or Dual]).
3. Set the reporting range (Setup>Analog Output>CO Concentration, Min Max). Ensure that the upper span limit entered for the reporting range (in the Max field) is the maximum expected concentration of the undiluted gas.
4. Set the dilution factor as a gain, e.g., a value of 20 means 20 parts diluent and 1 part sample gas (Setup>Vars>Dilution Factor).
5. Calibrate the analyzer; ensure that the calibration span gas is either supplied through the same dilution system as the sample gas or has an appropriately lower actual concentration.

EXAMPLE: If the reporting range limit is set for 100 ppm and the dilution ratio of the sample gas is 20 gain, either:

- a span gas with the concentration of 100 ppm can be used if the span gas passes through the same dilution steps as the sample gas, or;
- a 5 ppm span gas must be used if the span gas is NOT routed through the dilution system.

4.1.6 SECOND GAS SENSOR OPTIONS CALIBRATION

For the optional O₂ sensor, calibrate per Section 4.5.1 during installation of the instrument.

For the optional CO₂ sensor, calibrate per Section 4.5.2 during installation of the instrument.

4.1.7 DATA RECORDING DEVICES

A strip chart recorder, data acquisition system or digital data acquisition system should be used to record data from the serial or analog outputs of the N300/N300M.

- If analog readings are used, the response of the recording system should be checked against a NIST traceable voltage source or meter.
- Data recording devices should be capable of bi-polar operation so that negative readings can be recorded.
- For electronic data recording, make use of the internal data acquisition system (DAS) by setting up the Data Logger.

4.2 CALIBRATION PROCEDURES

Check that the pneumatic connections for the specific instrument configuration are as instructed in Section 2.3.2.

Verify/change (if needed) the settings as follows:

- User Units (unit of Measure): PPB (Setup>Vars>User Conc Units)
- Range Mode: SNGL (Setup>Vars>Range Mode)

Note

Tips for Setting the Expected Span Gas Concentration:

- **When setting expected concentration values, consider impurities in your span gas source.**
- **The expected CO span gas concentration should be 80% to 90% of the reporting range of the instrument.**

To calibrate or to perform a calibration check for basic configuration instruments, see Section 4.2.1.

To calibrate or to perform a calibration check for instruments with valve options, see Section 4.2.2.

To perform automatic calibration check for instruments with the internal span gas generator, see Section 4.2.2.2.

4.2.1 CALIBRATION AND CHECK PROCEDURES FOR BASIC CONFIGURATION

Although this Section uses the Calibration menu for both check and actual calibration, a check does not require the Calibration menu. Instead, while in Home page, simply flow the zero air or the CO span gas through the Sample port and check the reading after the Stability falls below 1.0 PPB (either in the gas graph or in the Dashboard).

Otherwise, follow the steps presented in Sections 4.2.1.1 and 4.2.1.2.

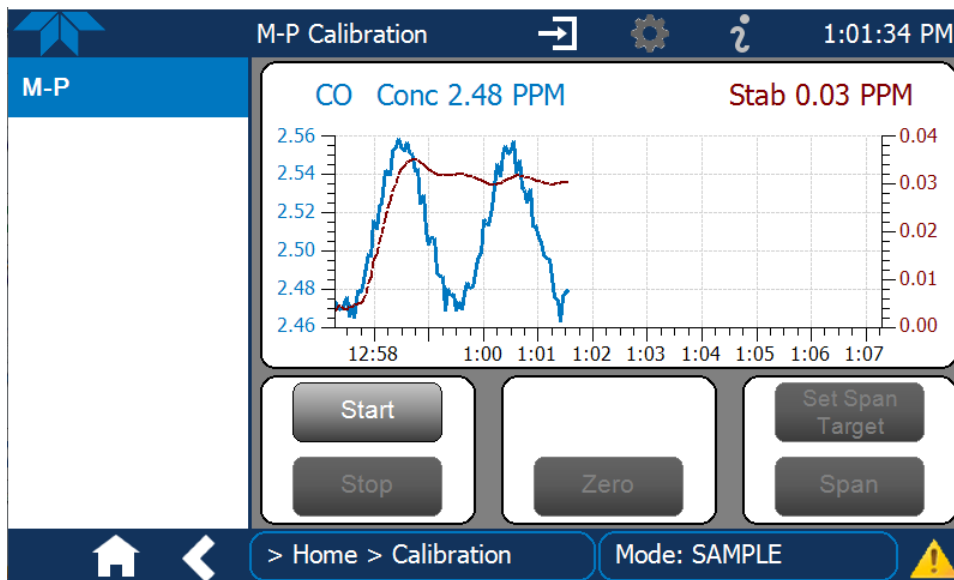

Figure 4-1. Multi-Point Calibration Page

4.2.1.1 ZERO CALIBRATION CHECK AND ACTUAL CALIBRATION

1. Go to the Calibration>M-P menu.
2. Input Zero air through the Sample port and press the Start button.
3. Either check or calibrate as follows:

<p style="text-align: center; color: blue; margin: 0;">CHECK ONLY:</p> <ol style="list-style-type: none"> a. Wait for reading to stabilize, then press Stop. b. Check and record the reading. 	<p style="text-align: center; color: blue; margin: 0;">ACTUAL CALIBRATION:</p> <ol style="list-style-type: none"> a. Wait for reading to stabilize. b. Press the Zero button. c. Press Stop and check the reading.
--	--

4.2.1.2 SPAN CALIBRATION CHECK AND ACTUAL CALIBRATION

1. While still in the Calibration>M-P menu, input CO Span gas through the Sample port and press the Start button.
2. Either check or calibrate as follows (note that reaching stability can sometimes take an hour or more):

<p style="text-align: center; color: blue; margin: 0;">CHECK ONLY:</p> <ol style="list-style-type: none"> a. Wait to reach stability, then press Stop. b. Record the reading(s). 	<p style="text-align: center; color: blue; margin: 0;">ACTUAL CALIBRATION:</p> <ol style="list-style-type: none"> a. Wait to reach stability. b. Press the Set Span Target button and enter the CO concentration. c. Verify the concentration reading is the same as the CO concentration being supplied. d. If incorrect, wait to reach stability, then press the Span button. e. In the Cal Result window, press OK.
---	--
3. Press the Stop button and return to Home screen.

- In the Dashboard, check and record the Slope(s) and the Offset(s). (See Table 4-2 in Section 4.3 for expected/acceptable values).

4.2.2 CALIBRATION AND CHECK PROCEDURES WITH VALVE OPTION INSTALLED

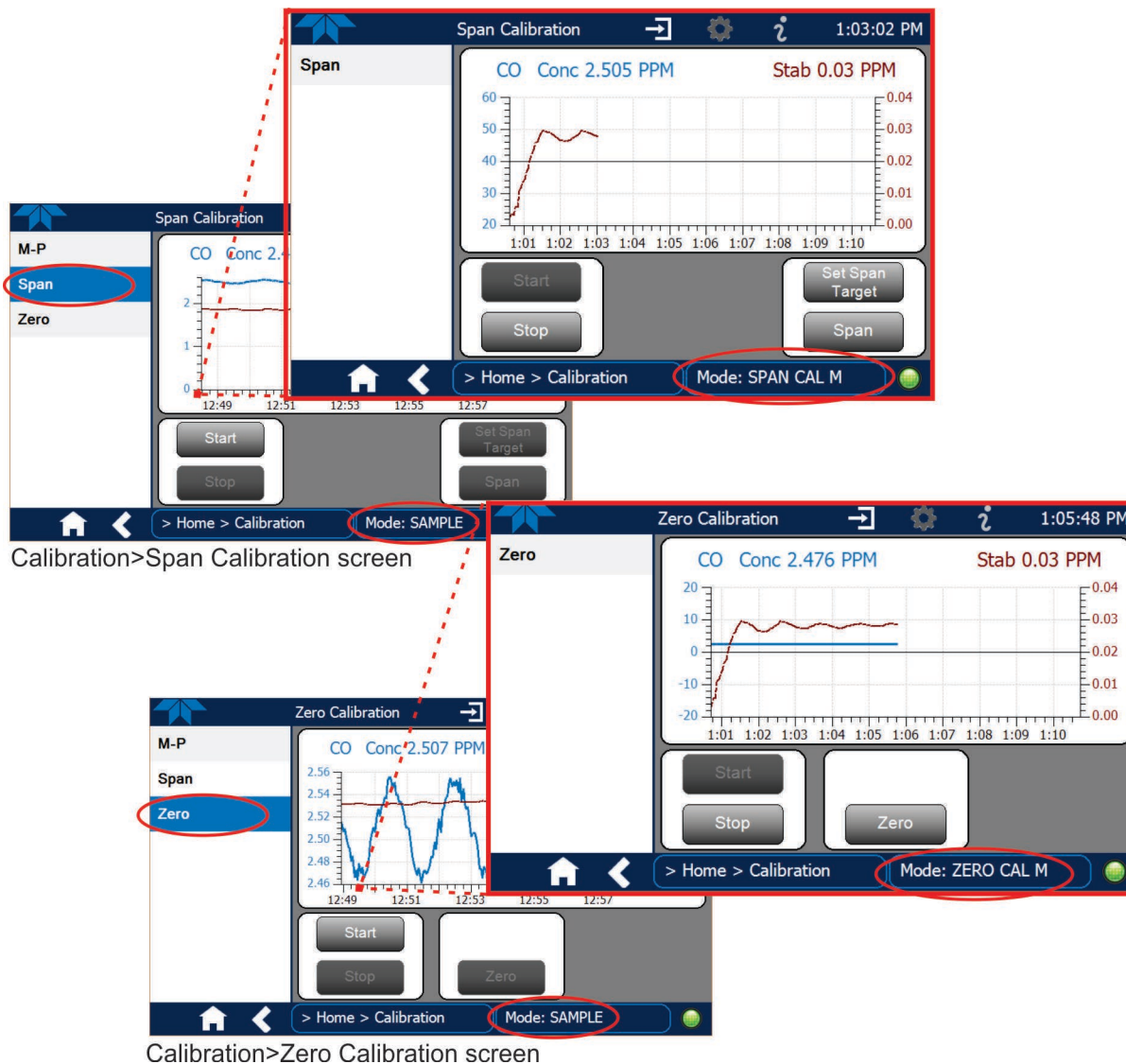

Figure 4-2. Zero and Span Calibration Screens

Follow the instructions in Section 4.2.1, except instead of the M-P menu, go to the Calibration>Zero menu for Zero cal and to the Calibration>Span menu for CO Span cal.

4.2.2.1 USE OF ZERO/SPAN VALVES WITH DIGITAL EXPANSION BOARD OPTION

Contact closures for controlling calibration checks are located on the rear panel CONTROL IN connector. Instructions for setup and use of these contacts are in Section 2.3.1.3.

4.2.2.2 AUTOMATIC ZERO/SPAN CAL CHECK (AUTO CAL) WITH ZERO/SPAN VALVE

The Auto Cal feature allows unattended periodic calibration checks with the ZERO/SPAN valves option by executing up to three separate preprogrammed sequences, labeled # 1, 2 and 3 (see Figure 4-3). Each calibration check can operate in either Zero mode or Span mode. The Auto Cal feature requires that the instrument remain in Calibration mode after the valves reset to ambient, in order to continue flagging the data until purging is complete. This is accomplished with the Auto Cal Purge Var.

To continue calibration until the system is purged, navigate to Setup>Vars>AutoCal Purge and use the Edit button to select the number of minutes for the purge duration.

To program the calibration checks for future execution (Figure 4-3), in the numbered sequence row (#1, #2, #3), click the Zero box or the Span box to select the valve to be switched open, then input the Start, Interval, and Duration parameters (refer

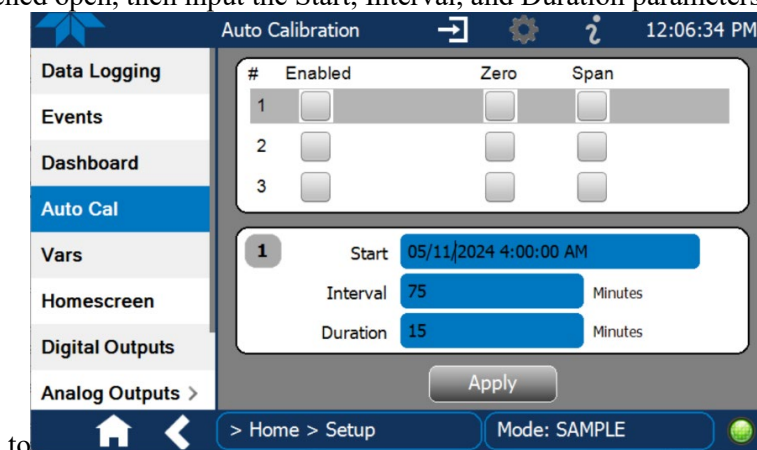

Figure 4-3. Auto Cal Page

Table 4-1) in the active field for that sequence (identified by the matching number in its upper left corner). Checking the Enabled box for that sequence allows the program to execute at the time, frequency and duration programmed, once the Apply button is clicked.

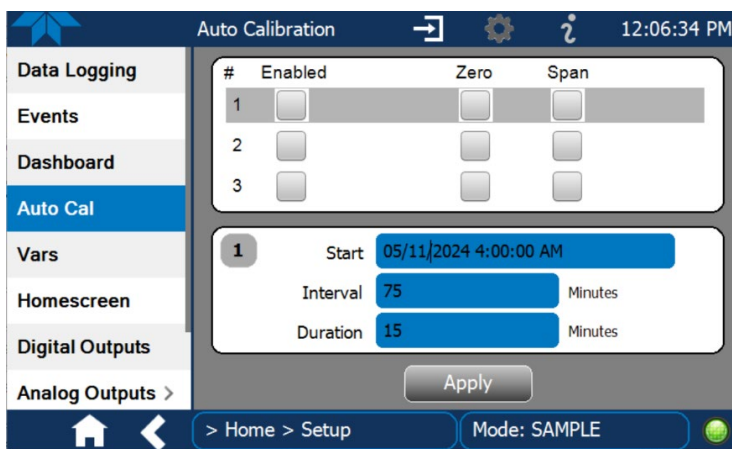

Figure 4-3. Auto Cal Page



N300, N300M

Table 4-1. Auto Cal Programming Sequence Execution

ATTRIBUTE	ACTION
Start	When the Enabled box is “on” <input checked="" type="checkbox"/> , the Sequence (identified by its number) begins on the date and time shown in the configurable Start field. (Click the field for the pop-up window and toggle between the Time (Hour/Minutes) and the Date (Year/Month/Day) attributes to edit as needed).
Interval	Number of minutes to skip between each Sequence execution. (Click the field to input the number of minutes in the pop-up window).
Duration	Number of minutes that each Sequence execution is to run. (Click the field to input the number of minutes in the pop-up window).

IMPORTANT

IMPACT ON READINGS OR DATA

- The programmed STARTING_TIME must be a minimum of 5 minutes later than the real time clock for setting real time clock (Setup>Instrument, Section 2.5.9).
- Avoid setting two or more sequences at the same time of the day.
- Any user-initiated calibration or calibration check that overlaps or coincides with a preprogrammed AutoCal check will override the AutoCal check.
- It is recommended that calibrations be performed using external sources of Zero Air and Span Gas whose accuracy is traceable to EPA standards.

4.3 CALIBRATION QUALITY

After completing any of the calibration procedures described above, it is important to evaluate the analyzer’s calibration **SLOPE** and **OFFSET** parameters. These values describe the linear response curve of the analyzer. The values for these terms, both individually and relative to each other, indicate the quality of the calibration.

To perform this quality evaluation, check that these parameters are within the limits listed in Table 4-2 below and frequently compare them to those values on the *Final Test and Validation Data Sheet* that was shipped with your instrument, which should not be significantly different. If they are, refer to the Troubleshooting content in Section 5.

Table 4-2. Calibration Data Quality Evaluation

FUNCTION	MINIMUM VALUE	OPTIMUM VALUE	MAXIMUM VALUE
SLOPE	0.700	1.000	1.300
OFFSET	-0.500	0.000	0.500

4.4 CALIBRATION OF THE ANALYZER’S ELECTRONIC SUBSYSTEMS

These calibrations include Dark Cal, Pressure Cal and Flow Cal, all located under the Utilities>Diagnostics menu.



4.4.1 DARK CALIBRATION TEST

The dark calibration test interrupts the signal path between the IR photo-detector and the remainder of the sync/demod board circuitry. This allows the instrument to compensate for any voltage levels inherent in the sync/demod circuitry that might affect the calculation of CO concentration.

Performing this calibration returns dark offset voltages for **MEAS** and for **REF** that are automatically added to the CPU's calculation routine. The two offset voltages from the last calibration procedure may be viewed in the Dashboard as Meas Detector and Ref Detector.

Activate this procedure in the Utilities>Diagnostics>Dark Calibration menu.

4.4.2 PRESSURE CALIBRATION

A sensor at the exit of the sample chamber continuously measures the pressure of the sample gas. The data for Sample Pressure are used to compensate the final gas concentration calculation for changes in atmospheric pressure and are stored in the CPU's memory.

IMPORTANT

IMPACT ON READINGS OR DATA

This calibration must be performed when the pressure of the sample gas is equal to ambient atmospheric pressure. Before performing the pressure calibration procedure, power off the sample gas pump through the software only, and disconnect the sample gas-line vent from the rear panel sample gas inlet.

ATTENTION

COULD DAMAGE INSTRUMENT AND VOID WARRANTY

Do NOT disconnect or reconnect the pump's power cable from its control PCA while the instrument is running. This will damage the PCA and render the instrument useless until the PCA or module is replaced.

1. Power down the pump via the Pump Control Mode Var.
2. Activate this procedure in the Utilities>Diagnostics>Pressure Cal menu.
3. When finished, reconnect the sample gas line vent to the rear panel sample gas inlet.
4. To restore power to the pump, make the selection based on the pump option installed: "Constant" for an HD pump; PID for PID pump.

4.4.3 FLOW CALIBRATION

The flow calibration allows the user to adjust the values of the sample flow rates as they appear in the Dashboard to match the actual flow rate measured at the sample inlet. This does not change the hardware measurement of the flow sensors, only the software-calculated values.



N300, N300M

To carry out this adjustment, connect an external, sufficiently accurate flow meter to the sample inlet per Section 5.6.5. Once the flow meter is attached and is measuring actual gas flow, use the Utilities>Diagnostics>Flow Cal menu to input the flow meter reading and calibrate.

IMPORTANT

IMPACT ON READINGS OR DATA

With the O₂ sensor option, subtract the O₂ sensor flow from the measured flow before entering the value in the Flow Cal menu.

4.5 CALIBRATION OF OPTIONAL SENSORS

This Section provides the calibration setup and procedures for the O₂ Sensor and the CO₂ Sensor options.

4.5.1 O₂ SENSOR CALIBRATION

Set up the O₂ pneumatics connections as follows:

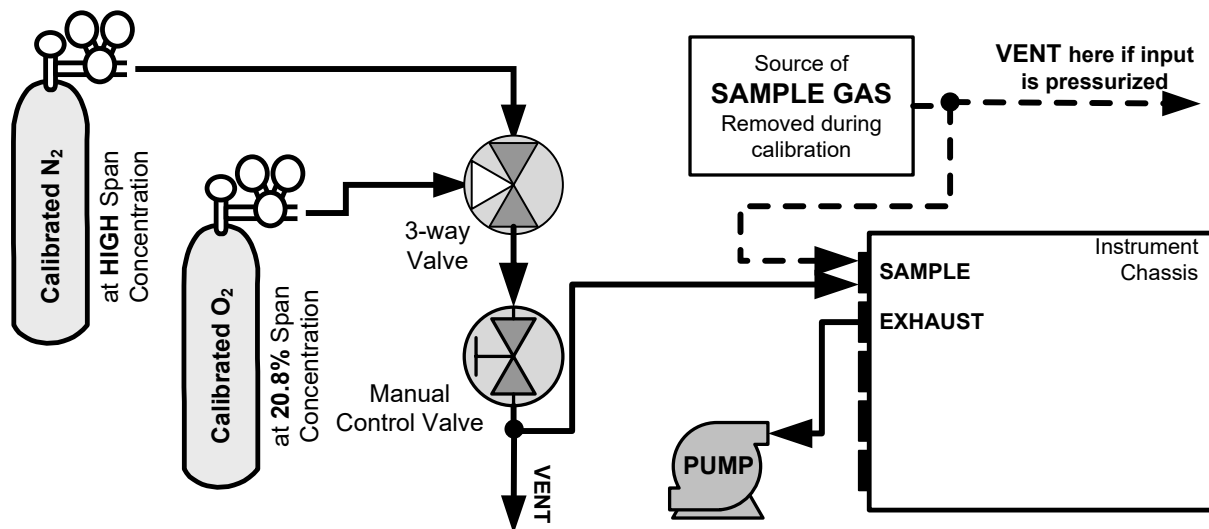

Figure 4-4. O₂ Sensor Calibration Set Up

O₂ SENSOR ZERO GAS: Teledyne API recommends using pure N₂ when calibration the zero point of your O₂ sensor option.

O₂ SENSOR SPAN GAS: Teledyne API recommends using 20.8% O₂ in N₂ when calibration the span point of your O₂ sensor option.

In the Calibration>O₂ menu, follow the steps in Section 4.2.1.2, this time setting the expected O₂ span gas concentration. This should be equal to the percent concentration of the O₂ span gas of the selected reporting range (default factory setting = 20.8%; the approximate O₂ content of ambient air).

4.5.2 CO₂ SENSOR CALIBRATION PROCEDURE

Set up the CO₂ pneumatics connections as follows:

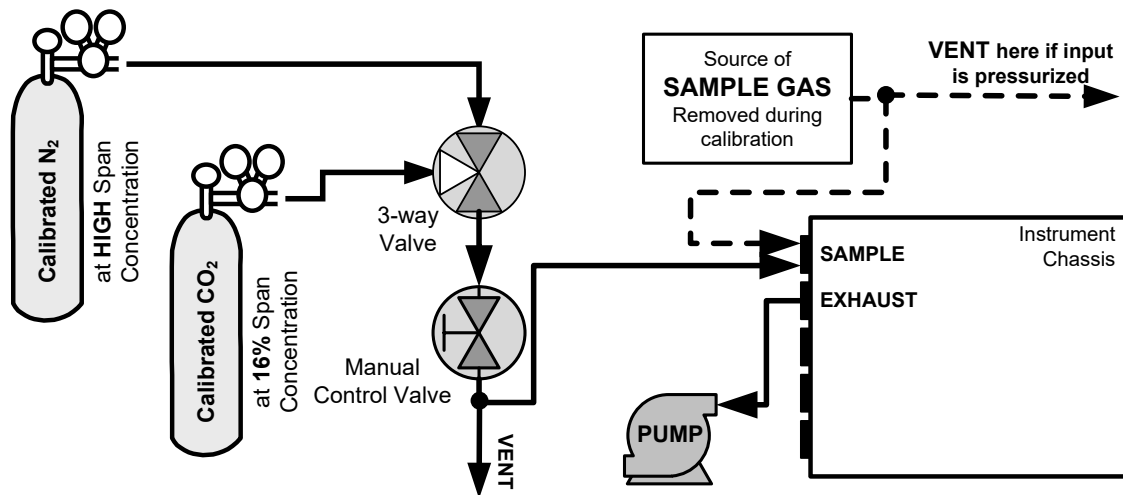

Figure 4-5. CO₂ Sensor Calibration Set Up

CO₂ SENSOR ZERO GAS: Teledyne API recommends using pure N₂ when calibration the zero point of your CO₂ sensor option.

CO₂ SENSOR SPAN GAS: Teledyne API recommends using 16% CO₂ in N₂ when calibration the span point of your CO₂ sensor option is 20%.

In the Calibration>CO₂ menu, follow the steps in Section 4.2.1.2, this time setting the expected CO₂ span gas concentration. This should be equal to the percent concentration of the CO₂ span gas of the selected reporting range (default factory setting = 12%).

4.6 EPA PROTOCOL CALIBRATION

When running the N300 for U.S. EPA compliance (the N300M does not have an EPA designation), always calibrate prior to use, adhering to the EPA designation requirements for this instrument. (The official “List of Designated Reference and Equivalent Methods” is published in the U.S. Federal Register and can be found on the EPA.gov website; this List specifies the settings and configurations for EPA calibration protocol). Pay strict attention to the built-in warning features, periodic inspection, regular zero/span checks, regular test parameter evaluation for predictive diagnostics and data analysis, and routine maintenance. Any instrument(s) supplying the zero air and span calibration gasses used must themselves be calibrated, and that calibration must be traceable to an EPA/NIST primary standard.

Comply with Code of Federal Regulations, Title 40 (downloadable from the U.S. Government Publishing Office on the govinfo.gov website, and with Quality Assurance Guidance documents available on the EPA website. Give special attention to specific regulations regarding the use and operation of ambient carbon monoxide analyzers (gas filter correlation).

5. MAINTENANCE AND SERVICE

Although this instrument requires little service, a few simple procedures should be performed regularly to ensure that it continues to operate accurately and reliably over its lifetime. In general, the exterior can be wiped down with a lightly damp cloth. Service and troubleshooting are covered in Section 5.7 of this manual.

5.1 MAINTENANCE SCHEDULE

Table 5-1 shows a typical maintenance scheduler. The actual frequency of performing these procedures can vary depending on the operating environment. In certain environments (i.e., dusty, very high ambient pollutant levels) some maintenance procedures may need to be performed more often than shown. Additionally, in some cases, there are local regulations or standards that also need to be considered.



WARNING – Electrical Shock Hazard

Disconnect power before performing any of the following operations that require entry into the interior of the analyzer.



Caution – Qualified Personnel

These maintenance procedures must be performed by qualified technicians only.

ATTENTION

COULD DAMAGE INSTRUMENT AND VOID WARRANTY

Always power off the instrument before disconnecting or reconnecting internal electrical assemblies. Failure to do so can cause damage to instrument.

Also, when cleaning (or any time), avoid spraying anything directly onto any part of the analyzer.

Important

IMPACT ON READINGS OR DATA

A Span and Zero Calibration Check (see CAL CHECK REQ'D Column of Table 5-1) must be performed following certain of the maintenance procedure listed below. To perform a CHECK of the instrument's Zero or Span Calibration, refer to Sections 4.2.1.1 and 4.2.1.2, respectively.

Alternatively, use the Auto Cal feature (Section 4.2.2.2).

Table 5-1. N300/N300M Maintenance Schedule

ITEM	ACTION	FREQ	CAL CHECK REQ'D	MANUAL	DATE PERFORMED												
Particulate Filter (47mm Teflon) (if equipped)	Replace	Weekly or As Needed	Yes														
Particulate Filter (Long Life DFU) If equipped	Replace	6 months or As Needed	Yes														
Verify Test Functions	Record and Analyze	Weekly or after any Maintenance or Repair	No														
Pump Diaphragm	Replace	Annually	Yes														
Perform Flow Check	Check Flow	Annually	No														
Perform Leak Check	Verify Leak Tight	Annually or after any Maintenance or Repair	No														
Pneumatic lines	Examine and Clean	As Needed	Yes if cleaned														
Cleaning	Clean	As Needed	Only if cover removed														

Table 5-2. N300/N300M Functions Record

FUNCTION	OPERATING MODE*	DATE RECORDED											
STABILITY	ZERO CAL												
CO MEAS	ZERO CAL												
MR RATIO	ZERO CAL												
	SPAN CAL												
PRES	SAMPLE												
PHT DRIVE	SAMPLE AFTER WARM- UP												
SLOPE	SPAN CAL												
OFFSET	ZERO CAL												

5.2 PREDICTIVE DIAGNOSTICS

These Functions can be used to predict failures by looking at how their values change over time. Initially it may be useful to compare the state of these functions to the values recorded on the printed record of the Final Test and Validation Data Sheet for your instrument. Table 5-3 can be used as a basis for taking action as these values change with time. The Data Logger (internal data acquisition system or DAS) is a convenient way to record and track these changes (Section 2.5.1). Use NumaView™ Remote to download and review this data from a remote location.

Table 5-3. Predictive Uses for Dashboard Functions

FUNCTION	CONDITION	BEHAVIOR	INTERPRETATION
STABILITY	Zero Cal	Increasing	<ul style="list-style-type: none"> • Pneumatic Leaks – instrument & sample system • Detector deteriorating
MEAS DETECTOR	Zero Cal	Decreasing	<ul style="list-style-type: none"> • Source Aging • Detector deteriorating • Optics getting dirty or contaminated
MR RATIO	Zero Cal	Increasing	<ul style="list-style-type: none"> • Source Aging • Detector deteriorating • Contaminated zero gas (H₂O)
		Decreasing	<ul style="list-style-type: none"> • Source Aging • Detector deteriorating • GFC Wheel Leaking • Pneumatic Leaks • Contaminated zero gas (CO)
	Span Cal	Increasing	<ul style="list-style-type: none"> • Source Aging • Pneumatic Leaks – instrument & sample system • Calibration system deteriorating • GFC Wheel Leaking
		Decreasing	<ul style="list-style-type: none"> • Source Aging • Calibration system deteriorating
SAMPLE PRESSURE	Sample	Increasing > 1"	<ul style="list-style-type: none"> • Pneumatic Leak between sample inlet and Sample Cell • Change in sampling manifold
		Decreasing > 1"	<ul style="list-style-type: none"> • Dirty particulate filter • Pneumatic obstruction between sample inlet and Sample Cell • Obstruction in sampling manifold
PHT DRIVE	Any, but with Bench Temp at 48°C	Increasing	<ul style="list-style-type: none"> • Mechanical Connection between IR-Detector and Sample Cell deteriorating • IR-Photodetector deteriorating
OFFSET	Zero Cal	Increasing	• See above, <u>MR Ratio - Zero Cal Decreasing</u>
		Decreasing	• See above, <u>MR Ratio - Zero Cal Increasing</u>
SLOPE	Span Cal	Increasing	• See above, <u>MR Ratio - Span Cal Decreasing</u>
		Decreasing	• See above, <u>MR Ratio – Span Cal Increasing</u>



5.3 OPERATIONAL HEALTH CHECKS

Navigate to the Utilities>USB Utilities>Report menu (Figure 5-1) to download a report on the basic operations of the instrument. To download the report for your own viewing on a computer or to send to others, insert a flash drive into a front panel USB port and press the Download button, which is enabled when the instrument detects the flash drive.

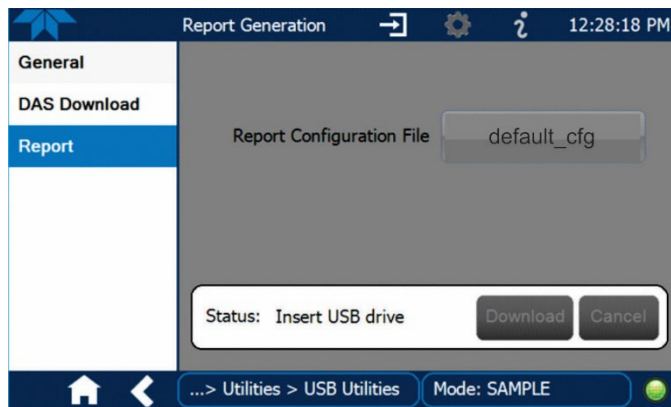

Figure 5-1: Report Generation Page

The report can also be set to generate periodically and sent to a Web services “cloud” where it is available for viewing by Teledyne API technical support personnel. Set this function with two Vars:

Setup>Vars>Upload Report to Cloud: set to True.

Setup>Vars>Report Upload>Interval: edit the number of hours between report uploads.



5.4 SOFTWARE/FIRMWARE UPDATES

An automatic weekly check for updates can be enabled in the Setup>Vars>Periodically Check for Updates menu, and/or a check for updates can be prompted at any time in the Setup>Instrument>Remote Update page. Downloading updates can be performed either remotely (Section 5.4.1) or manually (Section 5.4.2).

5.4.1 REMOTE UPDATES

The instrument must be connected to a network that is connected to the Internet. In the Setup>Instrument menu, select the Remote Update menu and press the Check for Updates button. If an update is available, it can be downloaded through this page.

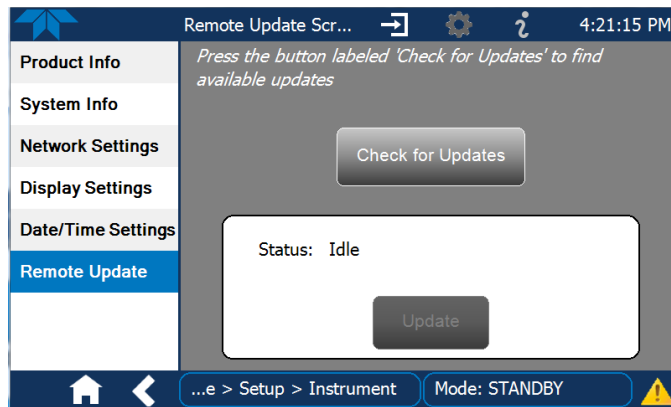

Figure 5-2. Remote Update Page

5.4.2 MANUAL RELOAD/UPDATE PROCEDURES

To reload or update firmware, first contact Technical Support to obtain the applicable file(s):

api-techsupport@teledyne.com (email), +1 800-324-5190 (toll free), +1 858-657-9800 (phone).

1. Follow Technical Support's instructions for copying the firmware files to the root directory of a flash drive.
2. Go to the Utilities>USB Utilities>General menu.

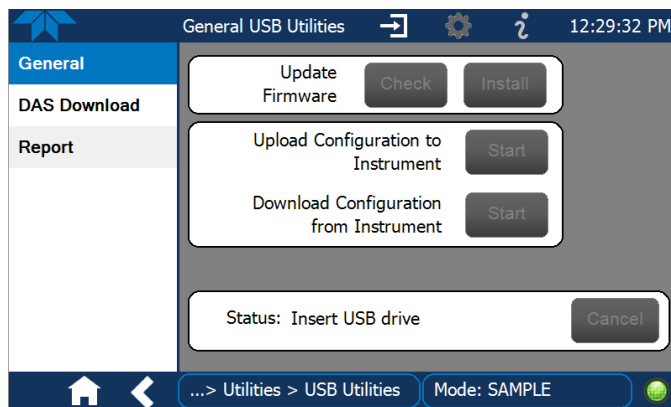

Figure 5-3. Manual Update Page (and other utilities)

3. Insert the flash drive into a front panel USB port and wait for the Status field to indicate that the drive has been detected.



N300, N300M

4. In the Update Firmware field, press the Check button for the instrument to determine whether the firmware on the flash drive is more recent than what is currently installed. Once it's been determined that the firmware is new, the Install button will be enabled; if the firmware version on the flash drive is the same as or older than the current firmware of the instrument, the Install button will not be enabled.
5. Press the Install button and note the messages in the Status field at the bottom of the page. Use the Cancel button if necessary.
6. When complete, as indicated in the Status field, press the Done button, which replaces the Cancel button, and remove the flash drive.
7. Power off and restart the instrument to complete the new firmware installation.

5.5 TIME ZONE CHANGES

There is an option to change between 12-hour and 24-hour format in the Setup>Vars menu (System Time Format). Effectively changing the Time Zone requires a specific procedure as follows:

1. In Setup>Instrument>Date/Time Settings select the applicable Time Zone.
1. Allow adequate time for the selected Time Zone to be properly accepted.
2. Verify: return to Home page then back to the Date/Time Settings page, and check that the selected Time Zone is now highlighted.
3. **Without making any other changes, power OFF the instrument and power ON again.**
4. Once restarted, return to the Date/Time Settings page where the newly selected Time Zone should be highlighted. (If not, it means that not enough time had passed for the instrument to accept the change before the power was cycled OFF).
5. After the Time Zone is implemented first (Steps 1 through 4), then other changes to the date and/or time can be made, and recycling the power is not necessary.

- ① Time zone change must be set first.
- ② Wait. Allow sufficient time to accept new Time Zone.
- ③ Verify. Return to Home page, then return to Date/Time Settings page.
- ④ After correct Time Zone is displayed, power recycle the instrument.
- ⑤ Only after Time Zone is selected and instrument rebooted, can other changes to date and/or time be made effectively.

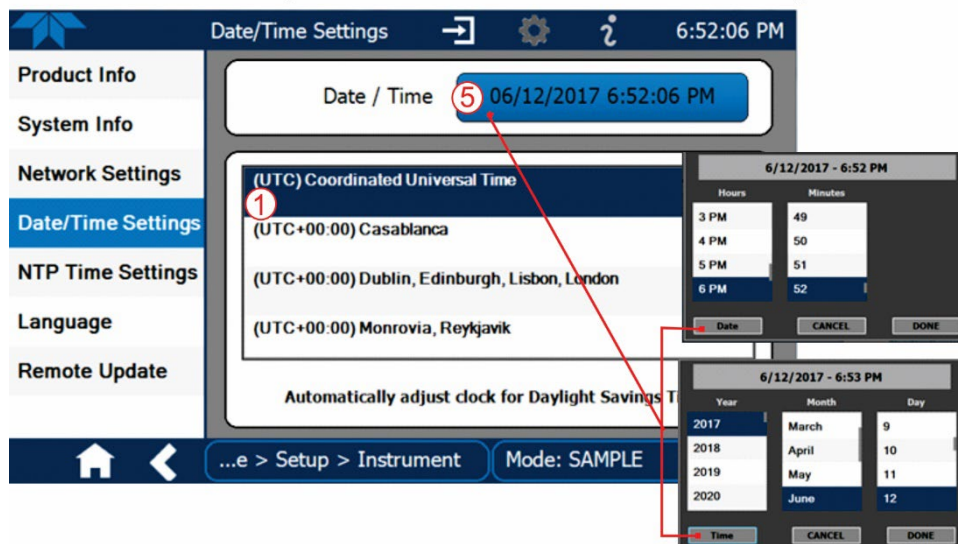

Changes to date and/or time do **not** require a reboot.

Figure 5-4. Time Zone Change Requirements



5.6 MAINTENANCE PROCEDURES

The following procedures are to be performed periodically as part of the standard maintenance of the N300. The actual frequency of performing these procedures can vary depending on the operating environment. Additionally, in some cases, there are local regulations or standards that also need to be considered.

In certain environments (e.g., dusty, very high ambient pollutant levels) some maintenance procedures may need to be performed more often than others.

5.6.1 REPLACING THE 47 MM SAMPLE PARTICULATE FILTER OPTION (N300)

if the instrument is equipped with the 47mm particulate filter, it should be inspected often for signs of plugging or contamination. It should be replaced according to the service interval schedule even without obvious signs of dirt, as filters with 1 and 5 μm pore size can clog up while retaining a clean look. We recommend that the filter and the wetted surfaces of the filter housing are handled as little as possible when you change the filter. Do not touch any part of the housing, filter element, PTFE retaining ring, glass cover or the o-ring with bare hands.

Important

IMPACT ON READINGS OR DATA

Use gloves or PTFE coated tweezers or similar handling to avoid contamination of the sample filter assembly. Do not touch any part of the housing, filter element, PTFE retaining ring, glass cover and the o-ring with bare hands, as contamination can negatively impact accuracy of readings.

To change the filter element:

1. Turn OFF the analyzer to prevent drawing debris into the instrument.
2. Open the N300 Analyzer's hinged rear panel and unscrew the knurled retaining ring on the filter assembly.

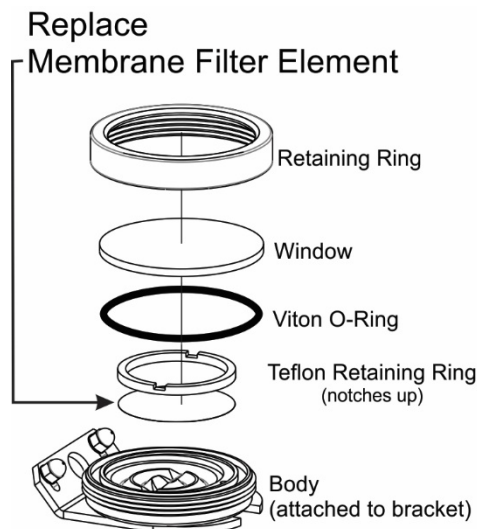

Figure 5-5. Sample Particulate Filter's Membrane Filter Element



N300, N300M

3. Noting the orientation of each component, carefully remove the Retaining Ring, the glass Window, the notched Teflon Retaining Ring, and the used Membrane Filter Element (the Viton o-ring may come up with the Window or it may remain nested in the Body).
4. Insert the new Membrane Filter Element, being careful that it is fully seated and centered in the bottom of the Body.
5. Ensuring that the Viton O-Ring is nested in the Body, reinsert the Teflon Retaining Ring with the notches up, then the glass Window, and finally, screw on the Retaining Ring and finger tighten.
6. Inspect and ensure that the Viton O-Ring is creating a proper seal all around.

5.6.2 CHANGING THE LONG-LIFE DFU FILTER OPTION (N300)

If the analyzer is equipped with the long-life DFU filter, follow these instructions to change it.

To replace:

1. Power OFF the analyzer to prevent drawing debris into the instrument.
2. Access the old filter by lowering the hinged portion of the rear panel.
3. Noting the orientation of the filter (imprinted arrow indicates direction of flow), remove filter's tie-down and disconnect its fittings. Dispose of according to code.
4. Install the replacement filter in the same orientation.
5. Secure with tie-down.
6. Close and secure hinged rear panel, power up instrument, and allow time for conditioning.
7. Conduct zero and span calibrations and allow time to stabilize.

5.6.3 REBUILDING THE SAMPLE PUMP

The diaphragm in the sample pump periodically wears out and must be replaced. A sample rebuild kit is available for the pump option installed (either HD or PID) – call Technical Support for the kit; refer to label on the pump itself for the part number. Instructions and diagrams are included with the kit. (Sections 5.7.5.1 and 5.7.5.6 have additional information about the pumps).

Always perform a Leak Check (Section 5.6.4) and a Flow Check (Section 5.6.5) after rebuilding the Sample Pump.

5.6.4 PERFORMING LEAK CHECKS

Leaks are the most common cause of analyzer malfunction; Section 5.6.4.1 presents a simple leak check procedure. Section 5.6.4.2 details a more thorough procedure.

5.6.4.1 VACUUM LEAK CHECK AND PUMP CHECK

This method is easy and fast. It detects but does not locate most leaks. It also verifies that the sample pump is in good condition.

1. Turn the analyzer ON and allow enough time for flows to stabilize.
2. Cap the sample inlet port.



N300, N300M

3. After several minutes, when the pressure has stabilized, view the Dashboard and note the SAMPLE PRESSURE reading.
4. If the reading is < 10 in-Hg, the pump is in good condition and there are no large leaks.
5. Check the sample gas flow. If the flow is <10 cm³/min and stable, there are no large leaks in the instrument's pneumatics.

5.6.4.2 PRESSURE LEAK CHECK

If you can't locate the leak by the above procedure, use the following procedure. Obtain a leak checker that has a pump, shut-off valve and pressure gauge. Alternatively, a convenient source of low-pressure gas is a tank of span gas, with the two-stage regulator adjusted to less than 15 psi with a shutoff valve and pressure gauge.



CAUTION **General Safety Hazard**

Do not use bubble solution with vacuum applied to the analyzer. The solution may contaminate the instrument. Do not exceed 15 PSIG pressure.

1. Turn OFF power to the instrument.
2. Install a leak checker or tank of gas as described above on the sample inlet at the rear panel.
3. Remove the instrument cover and locate the inlet side of the sample pump. Remove the flow assembly from the pump and plug it with the appropriate gas-tight fitting.
4. Pressurize the instrument with the leak checker, allowing enough time to fully pressurize the instrument through the critical flow orifice. Check each fitting with soap bubble solution, looking for bubbles. Once the fittings have been wetted with soap solution, do not re-apply vacuum, as it will suck soap solution into the instrument and contaminate it. Do not exceed 15 psi pressure.
5. If the instrument has one of the zero and span valve options, the normally closed ports on each valve should also be separately checked. Connect the leak checker to the normally closed ports and check with soap bubble solution.
6. Once the leak has been located and repaired, the leak-down rate should be < 1 in-Hg (0.4 psi) in 5 minutes after the pressure is shut off.

5.6.5 PERFORMING A SAMPLE FLOW CHECK



CAUTION **General Safety Hazard**

Always use a separate calibrated flow meter capable of measuring flows in the 0 – 1000 cc/min range to measure the gas flow rate though the analyzer.

DO NOT use the built in flow measurement viewable from the Front Panel of the instrument. This measurement is only for detecting major flow interruptions such as clogged or plugged gas lines.



N300, N300M

See Figure 2-2 for SAMPLE port location.

1. Attach the Flow Meter to the sample inlet port on the rear panel. Ensure that the inlet to the Flow Meter is at atmospheric pressure.
2. Sample flow should be 800 cc/min \pm 10%.
3. Once an accurate measurement has been recorded by the method described above, adjust the analyzer's internal flow sensors (See Section 4.4.3).

Low flows indicate blockage somewhere in the pneumatic pathway, typically a plugged sintered filter or critical flow orifice in one of the analyzer's flow control assemblies. High flows indicate leaks downstream of the flow control assembly.

5.6.6 CLEANING THE OPTICAL BENCH

The N300/N300M sensor assembly and optical bench are complex and delicate. Disassembly and cleaning is not recommended. Please check with the factory before disassembling the optical bench.

5.7 TROUBLESHOOTING

This section contains a variety of methods for identifying the source of performance problems with the analyzer. Also included in this are procedures that are used in repairing the instrument.



Qualified Personnel

The operations outlined in this Section must be performed by qualified maintenance personnel only.



WARNING - Risk of Electrical Shock

Some operations need to be carried out with the instrument open and running.

Exercise caution to avoid electrical shocks and electrostatic or mechanical damage to the analyzer.

Do not drop tools into the analyzer or leave those after your procedures.

Do not short or touch electric connections with metallic tools while operating inside the analyzer.

Use common sense when operating inside a running analyzer.

The analyzer has been designed so that problems can be rapidly detected, evaluated and repaired. During operation, it continuously performs diagnostic tests and provides the ability to evaluate its key operating parameters without disturbing monitoring operations.

A systematic approach to troubleshooting will generally consist of the following steps:

1. Note Alerts and take corrective action as necessary.
2. Compare the values of the Dashboard functions to factory values. Note any major deviations from the factory values and take corrective action.
3. Use the internal electronic status LEDs to determine whether related components are operating properly.



N300, N300M

4. SUSPECT A LEAK FIRST!

- Technical Support data indicate that the majority of all problems are eventually traced to leaks in the internal pneumatics of the analyzer or the diluent gas and source gases delivery systems.
- Check for gas flow problems such as clogged or blocked internal/external gas lines, damaged seals, punctured gas lines, a damaged / malfunctioning pumps, etc.

5.7.1 FAULT DIAGNOSIS WITH ALERTS

The most common and/or serious instrument failures will result in a warning message, called an Alert. Table 5-4 lists some of the more common Alert messages, along with their meaning and recommended corrective action.

It should be noted that if more than two or three warning Alerts occur at the same time, it is often an indication that some fundamental analyzer sub-system (power supply, mainboard) has failed, rather than being an indication of the specific failures referenced by the warning Alerts.

Table 5-4. Alerts - Indicated Failures

ALERT MESSAGE	FAULT CONDITION	POSSIBLE CAUSES
BENCH TEMP WARNING	The optical bench temp is controlled at 48 ± 2 °C.	Bad bench heater Bad bench temperature sensor
BOX TEMP WARNING	Box Temp is < 5 °C or > 48 °C.	NOTE: Box temperature typically runs ~7°C warmer than ambient temperature. Poor/blocked ventilation to the analyzer. Stopped exhaust-fan Ambient temperature outside of specified range
CONFIG INITIALIZED	Configuration and Calibration data reset to original Factory state.	User erased data
DATA INITIALIZED	Data Storage in DAS was erased	User cleared data
DETECTOR TEMP WARNING	Detector Temp exceeds -15 °C	Failing Detector Chiller. Check PHT Drive.
PHOTO TEMP WARNING	PHT DRIVE exceeds maximum mVDC setting	Failed IR photo-detector Failed sync/demod board IR photo-detector improperly attached to the sample chamber Bench temp too high.
SAMPLE FLOW WARNING	Sample flow rate is out of range, either below minimum or above maximum.	Failed sample pump Blocked sample inlet/gas line Dirty particulate filter Leak downstream of critical flow orifice Failed flow sensor/circuitry
SAMPLE PRESSURE WARNING	Sample Pressure is <10 in-Hg or > 35 in-Hg Normally 29.92 in-Hg at sea level decreasing at 1 in-Hg per 1000 ft of altitude (with no flow – pump disconnected).	If sample pressure is < 10 in-hg: <ul style="list-style-type: none"> • Blocked particulate filter • Blocked sample inlet/gas line • Failed pressure sensor/circuitry If sample pressure is > 35 in-hg: <ul style="list-style-type: none"> • Pressurized sample gas. Install vent • Blocked vent line on pressurized sample/zero/span gas supply • Bad pressure sensor/circuitry



N300, N300M

ALERT MESSAGE	FAULT CONDITION	POSSIBLE CAUSES
SAMPLE TEMP WARN	Sample temperature is < 10°C or > 100°C.	Ambient temperature outside of specified range Failed bench heater Failed bench temperature sensor Fault with bench heater controller board
SOURCE WARNING	Occurs when IR Ref is either below the minimum mVDC setting or above the maximum mVDC setting. Either of these conditions will result in an invalid M/R ratio.	GFC Wheel stopped, or could be failure of: <ul style="list-style-type: none"> • PCA • IR source • IR photo-detector
SYSTEM RESET	The computer has rebooted.	This message occurs at power on. If you have not cycled the power on your instrument: Fatal error caused software to restart
WHEEL TEMP WARNING	The filter wheel temperature is outside specified limits.	Blocked cooling vents below GFC Assembly. Make sure that adequate clear space beneath the analyzer. Analyzer's top cover removed Wheel heater or its controller Wheel temperature sensor

5.7.2 FAULT DIAGNOSIS WITH DASHBOARD FUNCTIONS

In addition to being useful as predictive diagnostic tools, the functions viewable in the Dashboard can be used to isolate and identify many operational problems when combined with a thorough understanding of the analyzer's Theory of Operation (see Section 6).

The acceptable ranges for these functions are listed in the "Nominal Range" column of the analyzer *Final Test and Validation Data Sheet* shipped with the instrument. Values outside these acceptable ranges indicate a failure of one or more of the analyzer's subsystems. Functions whose values are still within the acceptable range but have significantly changed from the measurement recorded on the factory data sheet may also indicate a failure.

The following table contains some of the more common causes for these values to be out of range.

Table 5-5. Dashboard Functions - Indicated Failures

FUNCTIONS	INDICATED FAILURE(S)
RANGE	Incorrectly configured measurement range(s) could cause response problems with a Data logger or chart recorder attached to one of the analog output. If the Range selected is too small, the recording device will over range. If the Range is too big, the device will show minimal or no apparent change in readings.
STABILITY	Indicates noise level of instrument or CO concentration of sample gas (see Section 5.7.7.2 for causes).
IR MEASURE & IR REFERENCE	If the value displayed is too high* the IR Source has become brighter. If the value displayed is too low or constantly changing and the IR Reference is OK: <ul style="list-style-type: none"> • Loose connector or wiring If the value displayed is too low or constantly changing and the IR Reference is bad: <ul style="list-style-type: none"> • GFC Wheel stopped, or rotation is too slow • Failed IR source • Failed IR photo-detector <p>*Note that the full-scale range of the detector is up to 2990mV. If the Measure or Reference values are at 2990mV, adjust the "Amplifier Gain Pot" VAR to bring the readings down to 90% of scale (~ 2700mV).</p>



N300, N300M

FUNCTIONS	INDICATED FAILURE(S)
MR Ratio	When the analyzer is sampling zero air and the ratio is too low: <ul style="list-style-type: none"> • The reference cell of the GFC Wheel is contaminated or leaking. • The alignment between the GFC Wheel and the segment sensor, the M/R sensor or both is incorrect. When the analyzer is sampling zero air and the ratio is too high: <ul style="list-style-type: none"> • Zero air is contaminated • Failed IR photo-detector
SAMPLE PRESSURE	See Table 5-4 for SAMPLE PRESSURE WARN.
PUMP FLOW	Check for gas flow problems (see Section 5.7.5).
SAMPLE TEMP	SAMPLE TEMP should be close to BENCH TEMP. Temperatures outside of the specified range or oscillating temperatures are cause for concern.
BENCH TEMP	Bench temp control improves instrument noise, stability and drift. Temperatures outside of the specified range or oscillating temperatures are cause for concern. Table 5-4 for BENCH TEMP WARNING.
WHEEL TEMP	Wheel temp control improves instrument noise, stability and drift. Outside of set point or oscillating temperatures are causes for concern. See Table 5-4 for WHEEL TEMP WARNING.
BOX TEMP	If the box temperature is out of range, check fan in the power supply module. Areas to the side and rear of instrument should allow adequate ventilation. See Table 5-4 for BOX TEMP WARNING.
DETECTOR TEMP	Typical value is < -15°C. If greater than -15°C, check the PHT Drive.
PHT DRIVE	If this drive voltage is out of range it may indicate one of several problems: <ul style="list-style-type: none"> • A poor mechanical connection between the photodetector, its associated mounting hardware and the absorption cell housing; • An electronic failure of the IR Photo-Detector's built-in cooling circuitry, or; • A temperature problem inside the analyzer chassis. In this case other temperature warnings would also be active such as BENCH TEMP WARNING or BOX TEMP WARNING.
SLOPE	Values outside range indicate: <ul style="list-style-type: none"> • Contamination of the zero air or span gas supply • Instrument is miscalibrated • Blocked gas flow • Contaminated or leaking GFC Wheel (either chamber) • Faulty IR photo-detector • Faulty sample faulty IR photo-detector pressure sensor (P1) or circuitry • Invalid M/R ratio (see above) • Bad/incorrect span gas concentration
OFFSET	Values outside range indicate: <ul style="list-style-type: none"> • Contamination of the zero air supply • Contaminated or leaking GFC Wheel (either chamber) • Faulty IR photo-detector

5.7.3 USING THE DIAGNOSTIC SIGNAL I/O FUNCTIONS

The signal I/O functions in the Utilities>Diagnostics menu can be used to help determine whether any faults exist. Some of the digital signals can be controlled through the Setup menu. These signals are useful for troubleshooting in three ways:

- The technician can view the raw, unprocessed signal level of the analyzer's critical inputs and outputs.

- Many of the components and functions that are normally under algorithmic control can be manually exercised.
- The technician can directly control the signal level Analog and Digital Output signals.

This allows the technician to observe systematically the effect of directly controlling these signals on the operation of the analyzer. Use the Utilities>Diagnostics menu to view the raw voltage of an input signal or the Setup menu to control the state of an output voltage or control signal.

5.7.4 FAULT DIAGNOSIS WITH LEDs

The following illustrations show smartboard components that can be useful in determining fault conditions.

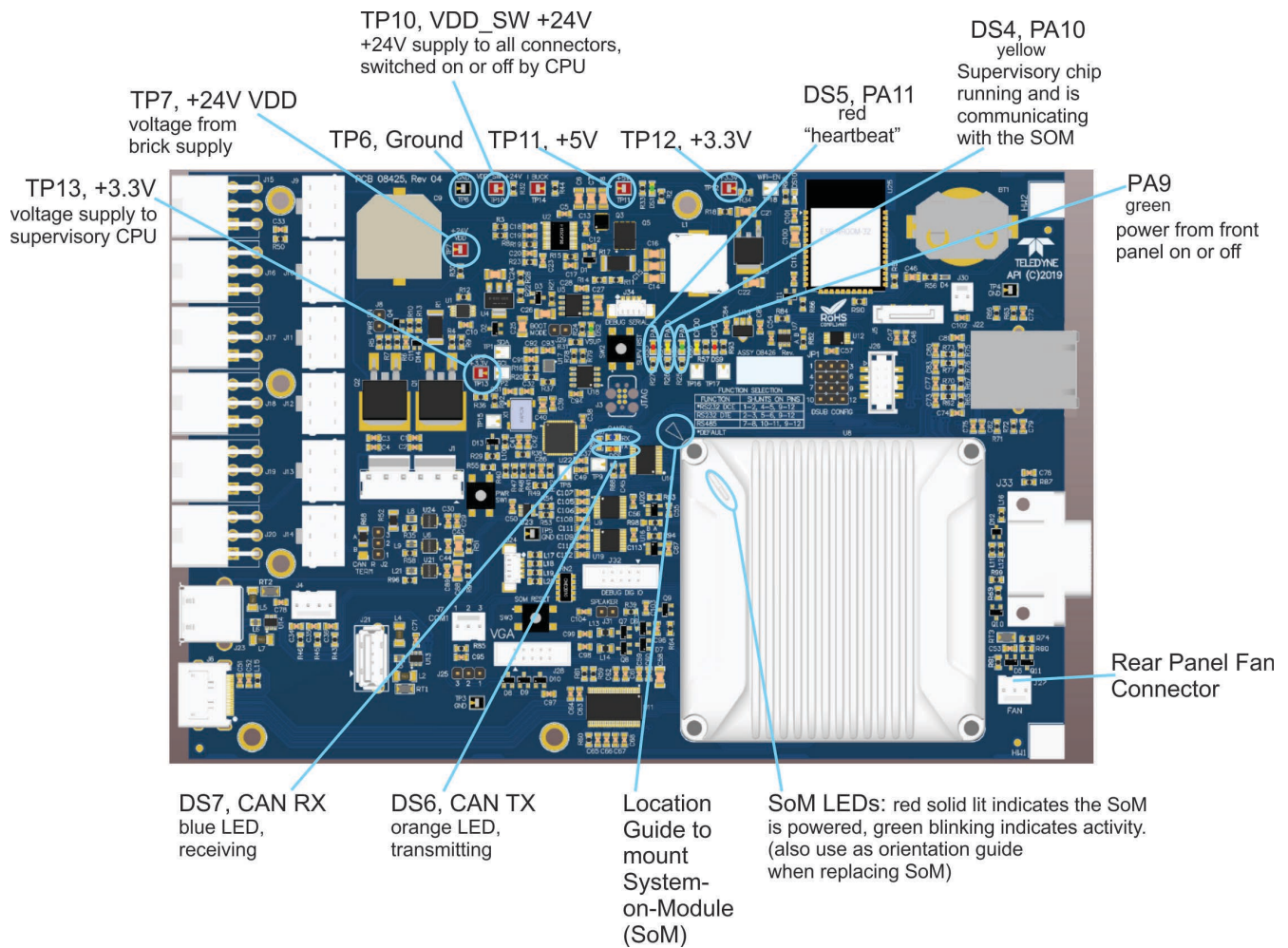

Figure 5-6. Mainboard



N300, N300M

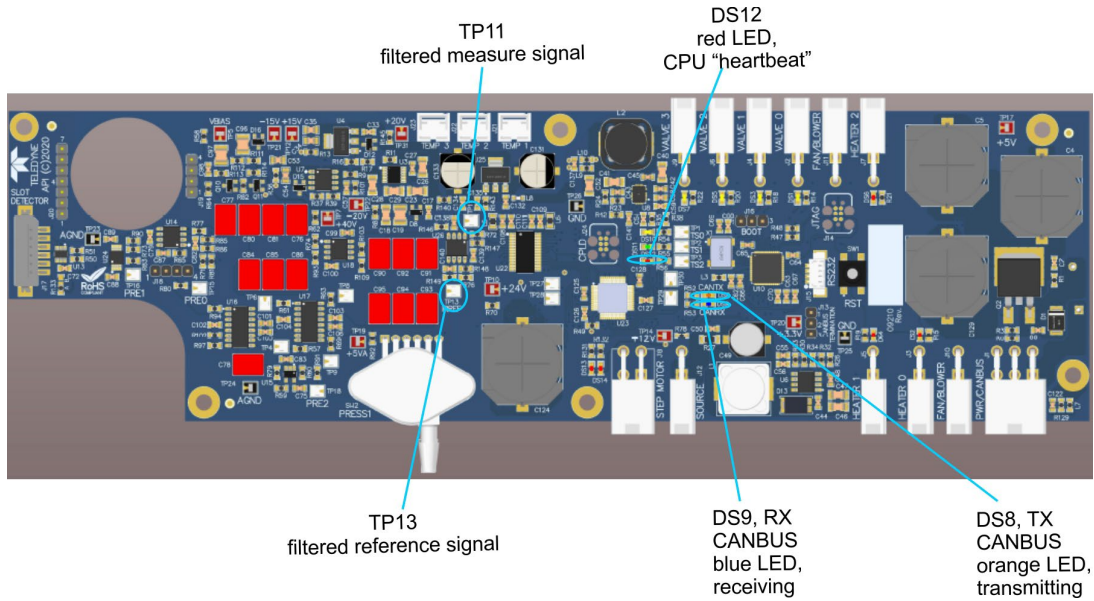

Figure 5-7. GFC Sensor Board LEDs

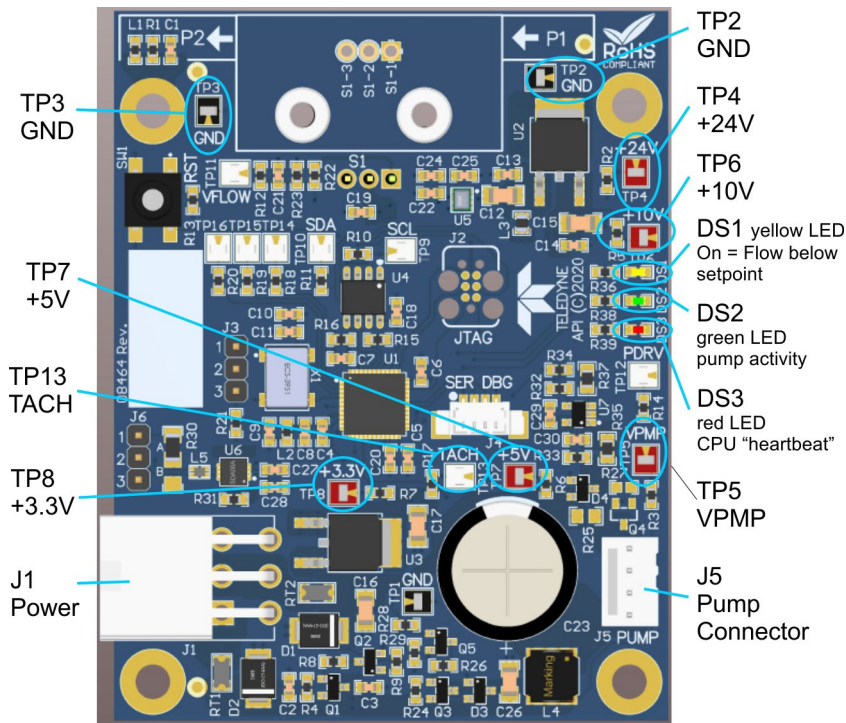

Figure 5-8. DC Pump Control Board LEDs

5.7.5 FLOW PROBLEMS

When troubleshooting flow problems, it is a good idea to first confirm that the actual flow and not the analyzer’s flow sensor and software are in error, or the flow meter is in error. Use an independent, calibrated volumetric flow meter to perform a flow check as described in Section 5.6.5.



N300, N300M

The N300/N300M has one main gas flow path. With a valve option installed, there are several subsidiary paths but none of those are displayed on the front panel or stored by the data acquisition system.

With the O₂ sensor option installed, a third gas flow controlled with a critical flow orifice is added, but this flow is not measured or reported.

In general, flow problems can be divided into three categories:

- Flow is too high
- Flow is greater than zero, but is too low, and/or unstable
- Flow is zero (no flow)

When troubleshooting flow problems, it is crucial to confirm the actual flow rate without relying on the analyzer's flow display. The use of a flow meter as described above is essential.

The flow diagrams in Section 2.3.3 can help in trouble-shooting flow problems.

5.7.5.1 FLOW IS ZERO

The unit displays a SAMPLE FLOW Alert, or the SAMPLE FLOW Dashboard function reports a zero or very low flow rate. The instrument has a controlled pump that is either HD non-PID (Figure 5-9) or STD PID (Figure 5-10), both of which are controlled by the same board (see Figure 5-8 for LED descriptions and Figure 5-13 for connectors).

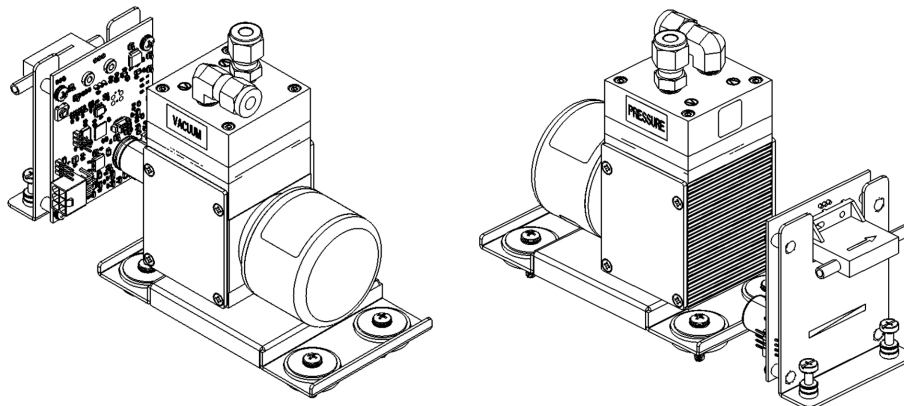

Figure 5-9. HD non-PID Controlled Pump

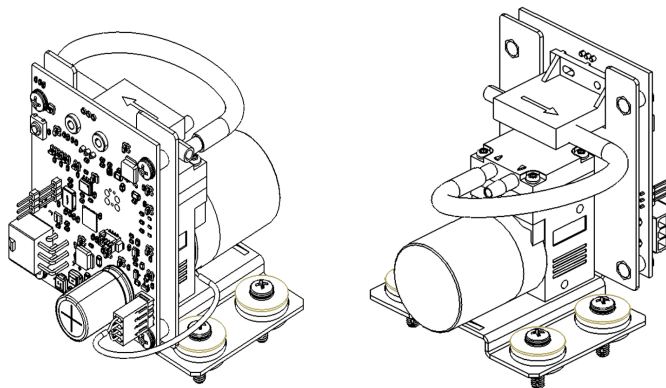

Figure 5-10. STD PID Controlled Pump



N300, N300M

Confirm that the sample pump is operating (turning). If not, use a DC voltmeter to make sure that power is being supplied to the pump .

1. Check that the communication/activity LEDs on the pump board (Figure 5-8) are illuminated and/or blinking. If not, check power to board via its test points.
2. If pump board LEDs are active and pump is not operating, check the “Pump Control Mode” VAR and make sure its setting is either PID (for the PID controlled pump, Figure 5-10) or Constant (for the larger orifice flow controlled pump, Figure 5-9).
3. Check flow calibration (Section 4.4.3).
4. If DC power is being supplied to the pump, but it is not turning, replace the pump module; refer to Figure 5-13 for control board connectors.
5. If the pump is operating but the unit reports no gas flow, perform a flow check as described in Section 5.6.5.
6. If no independent flow meter is available:
 - Disconnect the gas lines from both the sample inlet and the exhaust outlet on the rear panel of the instrument.
 - Make sure that the unit is in basic SAMPLE Mode.
 - Place a finger over an Exhaust outlet on the rear panel of the instrument.
 - If gas is flowing through the analyzer, you will feel pulses of air being expelled from the Exhaust outlet.
7. If gas flows through the instrument when it is disconnected from its sources of zero air, span gas or sample gas, the flow problem is most likely not internal to the analyzer. Check to make sure that:
 - All calibrators/generators are turned on and working correctly.
 - Gas bottles are not empty or low.
 - Valves, regulators and gas lines are not clogged or dirty.

5.7.5.2 Low Flow

1. Check flow calibration (Section 4.4.3).
2. Check if the pump diaphragm is in good condition. If not, rebuild the pump (see Section 5.6.2). Check with Technical Support for information on pump rebuild kits.
3. Check for leaks as described in Section 5.6.3. Repair the leaking fitting, line or valve and re-check.
4. Check the sample filter and the orifice filter for dirt. Replace filters (see 5.6.1).
5. Check for partially plugged pneumatic lines, or valves. Clean or replace them.
6. Check for plugged or dirty critical flow orifices. Replace them.
7. If an IZS option is installed in the instrument, run CALZ and CALS. If the flow increases, then suspect a bad sample/cal valve.

5.7.5.3 High Flow

The most common cause of high flow is a leak in the sample flow control assembly or between there and the pump. If no leaks or loose connections are found in the fittings or the gas line between the orifice and the pump, replace the critical flow orifice(s) inside the sample flow control assembly.



N300, N300M

5.7.5.4 FLOW ALERT

A front panel display flow Alert means that there is inadequate gas flow. There are four conditions that might cause this:

1. A leak upstream or downstream of the flow sensor
2. A flow obstruction upstream or downstream of the flow sensor
3. Bad Flow Sensor Board
4. Bad pump

To determine which case is causing the flow problem, view the sample pressure and sample flow functions on the front panel. If the sample pressure is reading abnormally low, then the cause is likely a flow obstruction upstream of the flow sensor. First, check the sample filter and make sure it is not plugged and then systematically check all the other components upstream of the orifice to ensure that they are not obstructed.

If the sample pressure is reading normal but the sample flow is reading low then it is likely that the pump diaphragm is worn or there is an obstruction downstream of the flow sensor.

5.7.5.5 ACTUAL FLOW DOES NOT MATCH DISPLAYED FLOW

If the actual flow measured does not match the displayed flow, but is within the limits of 720-880 cc/min, adjust the calibration of the flow measurement as described in Section 5.6.5.

5.7.5.6 SAMPLE PUMP

The sample pump starts shortly after the instrument is powered up and all modules have been initiated:

- The STD PID controlled pump, which runs on a PID loop control, requires about 15 minutes to get up to speed.
 - In the Setup>Vars menu, Pump Control Mode set to PID.
- The HD non-PID controlled pump requires no additional waiting time as it runs at 100% constant flow, pulling against an orifice for flow control.
 - In the Setup>Vars menu, Pump Control Mode set to Constant, and Pump Constant Drive set to 100%.

With the Sample Inlet plugged, the Pressure value should read about 10 in-Hg for a pump that is in good condition. The pump module may need to be replaced if the reading is above 10 in-Hg. If the Sample Flow reading is greater than 10 cc/min, there is a leak in the pneumatic lines.



5.7.6 CALIBRATION PROBLEMS

5.7.6.1 MISCALIBRATED

There are several symptoms of miscalibration, indicated by out of range Slopes and Offsets as viewed in the display, typically caused by the following:

1. Bad span gas. This can cause a large error in the slope and a small error in the offset. Delivered from the factory, the N300 Analyzer's slope is within $\pm 15\%$ of nominal. Bad span gas will cause the analyzer to be calibrated to the wrong value. If in doubt have the span gas checked by an independent lab.
2. Contaminated zero gas. Excess H₂O can cause a positive or negative offset and will indirectly affect the slope.
3. Dilution calibrator not set up correctly or is malfunctioning. This will also cause the slope, but not the zero, to be incorrect. Again, the analyzer is being calibrated to the wrong value.
4. Too many analyzers on the manifold. This can cause either a slope or offset error because ambient gas with its pollutants will dilute the zero or span gas.

5.7.6.2 NON-REPEATABLE ZERO AND SPAN

As stated earlier, leaks both in the analyzer and in the external system are a common source of unstable and non-repeatable readings.

1. Check for leaks in the pneumatic systems as described in Section 5.6.3. Also consider pneumatic components in the gas delivery system outside the N300/N300M such as:
 - A change in zero air source such as ambient air leaking into zero air line, or
 - A change in the span gas concentration due to zero air or ambient air leaking into the span gas line.
2. Once the instrument passes a leak check, perform a flow check (see Section 5.6.5) to make sure adequate sample is being delivered to the sensor assembly.
3. A failing IR photo-detector may be at fault. Check the Measure and Reference readings in the Dashboard to ensure the signal levels are in the normal range and are quiet.
4. Confirm the sample pressure, wheel temperature, bench temperature, and sample flow readings are correct and have steady readings.
5. Disconnect the exhaust line from the optical bench near the rear of the instrument and plug this line into the SAMPLE inlet creating a pneumatic loop. The CO concentration (either zero or span) now must be constant. If readings become quiet, the problem is in the external pneumatics supplies for sample gas, span gas or zero air.
6. If pressurized span gas is being used with a zero/span valve option, make sure that the venting is adequate.



N300, N300M

5.7.6.3 INABILITY TO SPAN – NO SPAN BUTTON

1. Confirm that the carbon monoxide span gas source is accurate; this can be done by switching between two span-gas tanks. If the CO concentration is different, there is a problem with one of the tanks.
2. Check for leaks in the pneumatic systems as described in Section 5.6.3.
3. Make sure that the expected span gas concentration entered into the instrument during calibration is the correct span gas concentration and not too different from expected span value.
4. Check to make sure that there is no ambient air or zero air leaking into span gas line.

5.7.6.4 INABILITY TO ZERO – NO ZERO BUTTON

1. Confirm that there is a good source of zero air. Dilute a tank of span gas with the same amount of zero air from two different sources. If the CO Concentration of the two measurements is different, there is a problem with one of the sources of zero air.
2. Check for leaks in the pneumatic systems as described in 0.
3. If the analyzer has had zero/span valve options, the CO scrubber may need maintenance.
4. Check to make sure that there is no ambient air leaking into zero air line.

5.7.7 OTHER PERFORMANCE PROBLEMS

Dynamic problems (i.e. problems which only manifest themselves when the analyzer is monitoring sample gas) can be the most difficult and time consuming to isolate and resolve. The following provides an itemized list of the most common dynamic problems with recommended troubleshooting checks and corrective actions.

5.7.7.1 TEMPERATURE PROBLEMS

Individual control loops are used to maintain the set point of the absorption bench, filter wheel and IR photo-detector temperatures. If any of these temperatures are out of range or are poorly controlled, the analyzer will perform poorly.

BOX TEMPERATURE

View the Box Temp signal using the signal voltage in the Utilities>Diagnostics>Analog Inputs menu (Section 5.7.3). This parameter will vary with ambient temperature, but at ~30°C (6-7° above room temperature) the signal should be ~1450 mV.

SAMPLE TEMPERATURE

The Sample Temperature should closely track the bench temperature.



N300, N300M

BENCH TEMPERATURE

Some failures that could cause the Bench temperature to be incorrect may be an electronic failure or a faulty thermistor. Check the raw voltage reading in the Dashboard or in the Utilities>Diagnostics signals.

GFC WHEEL TEMPERATURE

Some failures that could cause the GFC Wheel temperature to be incorrect may be wheel heater failure or a faulty wheel thermistor temperature sensor.

IR PHOTO-DETECTOR TEC TEMPERATURE

Some failure that could cause the PHT DRIVE reading to fall out of range could be loose screws in the assembly or a failed photo-detector. Contact the factory for instructions.

5.7.7.2 EXCESSIVE NOISE

Noise is continuously monitored in the Stability reading and only becomes meaningful after sampling a constant gas concentration for at least 10 minutes. Compare the current reading with that recorded at the time of manufacture (included in the *Final Test and Validation Data Sheet* shipped with the unit from Teledyne API).

The most common cause of excessive noise is leaks, and running a leak check and flow check (Sections 0 and 5.6.5) will give an indication. Other causes may be traced by checking the Measure signal, the Reference signal, and the PHT Drive signal.

5.7.7.3 SLOW RESPONSE

If the analyzer starts responding too slow to any changes in sample, zero or span gas, check for the following:

- Dirty or plugged sample filter or sample lines.
- Sample inlet line is too long.
- Dirty or plugged flow restrictor. Check flows, pressures and, if necessary, change restrictor.
- Wrong materials in contact with sample - use glass, stainless steel or Teflon materials only.
- Insufficient time for purging lines upstream of the analyzer. Wait for stability is reached.
- Insufficient time for calibration gas source to stabilize. Wait until stability is reached.



N300, N300M

5.7.8 SUBSYSTEM CHECK FOR TROUBLESHOOTING

The preceding subsections discussed some methods for identifying possible sources of failures or performance problems within the analyzer. This subsection describes how to determine if a specific component or subsystem is at the root of the cause.

5.7.8.1 AC MAIN POWER



WARNING – Electrical Shock Hazard

Should the AC power circuit breaker trip, investigate and correct the condition causing this situation before turning the analyzer back on.

The instrument's electronic systems will operate with the power specification listed in Table 1-1 and will power on when the rear panel Hard Power switch is placed in the ON position. (If the power source is disrupted, the instrument will turn on once the power is restored). If the instrument doesn't start, check the following possible causes and possible solutions:

- Check the power cord for damage, such as whether it's cut or burned.
- Check that the power cord is adequately rated for the instrument's specified power rating.
- Note whether the instrument had been opened for maintenance; if so, place the rear panel Hard Power switch in the OFF position, and disconnect the power cord; then reopen the instrument and check that no wiring had been dislodged and that no tools were left inside.
- If the preceding checks reveal no cause, then check the fuse with an ohmmeter to determine its viability: carefully follow the instructions in Section 5.8.1 to remove the fuse for testing.
 - If the fuse is blown, replace it with a fuse of the correct specifications as instructed in Section 5.8.1.
 - If the fuse is not blown, or if the replacement fuse blows, then call Technical Support (Section 5.10).
- Last, check that the cable running from the power supply is properly seated in its connector at J1 on the Mainboard (Figure 5-12), and use a voltmeter to check TP7 on the Mainboard (Figure 5-6).

5.7.8.2 TOUCHSCREEN INTERFACE

Assuming that there are no wiring problems and that the DC power supplies are operating properly, the display screen should light and show the splash screen and other indications of its state as the CPU goes through its initialization process.

5.7.9 RS-232 COMMUNICATIONS

Problems with RS-232 connections usually center around such things as incorrect connector configuration, incorrect software settings, or improper/incomplete seating of the internal connector. Do not do anything inside the instrument without first contacting Technical Support.



5.8 SERVICE PROCEDURES

This section contains procedures that may need to be performed on rare occasions when a major component of the analyzer requires repair or replacement.

Note

Regular maintenance procedures are discussed in Section Section 5.6 and are not listed here). Also, there may be more detailed service notes for some of the below procedures. Contact Teledyne API's Technical Support Department (Section 5.10).



WARNING – Electrical Shock Hazard

Unless the procedure being performed requires the instrument to be operating, turn it off and disconnect power before opening the analyzer and removing, adjusting or repairing any of its components or subsystems.



Caution – Qualified Technician

The operations outlined in this chapter are to be performed by qualified maintenance personnel only.

5.8.1 REPLACING THE FUSE

ATTENTION

COULD DAMAGE INSTRUMENT AND VOID WARRANTY
Fuses do not typically fail without definite cause. Do not attempt to replace until after all measures to detect the cause of a power failure have been carried out, including Soft Power switch LED not lit (neither solid nor blinking), but Hard Power switch is in ON position and instrument's power cord properly connected at both ends. If an ohmmeter shows that the fuse is good, or if a new fuse blows, call Technical Support (Section 5.10).



WARNING – ELECTRICAL SHOCK HAZARD

Never pull out fuse drawer without ensuring that the Hard Power switch is in OFF position and power cord disconnected, to ensure there is no power to the instrument before checking/changing fuse.



N300, N300M

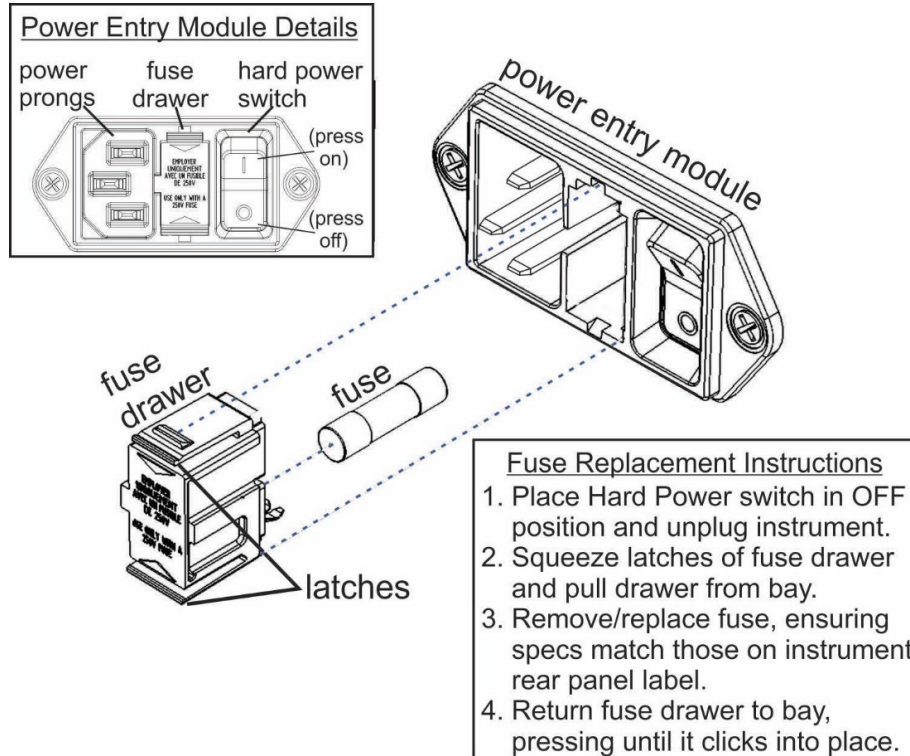

Figure 5-11. Fuse Access

5.8.2 REPLACING A MODULE

Each smart module has its own printed circuit board mounted to it so that the entire assembly can be quickly and efficiently swapped out:

1. Turn off the analyzer power (noting that the front panel switch LED should either be blinking or solid off before powering down via the rear panel switch).
2. Remove the power cord and the analyzer cover.
3. Disconnect tubing connected to the module.
4. Unplug the electrical connection to the module.
5. Unscrew the mounting screws that attach the module to the chassis and lift out the entire assembly.
6. If you received a complete replacement module with circuit board and mounting bracket attached, reverse the above steps to install.

Note

Ensure to carry out a leak check (Section 5.6.3) and a recalibration after the analyzer has warmed up for about 60 minutes.

ATTENTION

COULD DAMAGE INSTRUMENT AND VOID WARRANTY
Never connect or disconnect PCA electrical connectors while the instrument is powered on (“hot-swap”) as this will damage the PCA and require replacement.



N300, N300M

5.8.2.1 CONNECTORS ON MAINBOARD

Modules can be connected to any of the Mainboard's six CANBUS connectors.

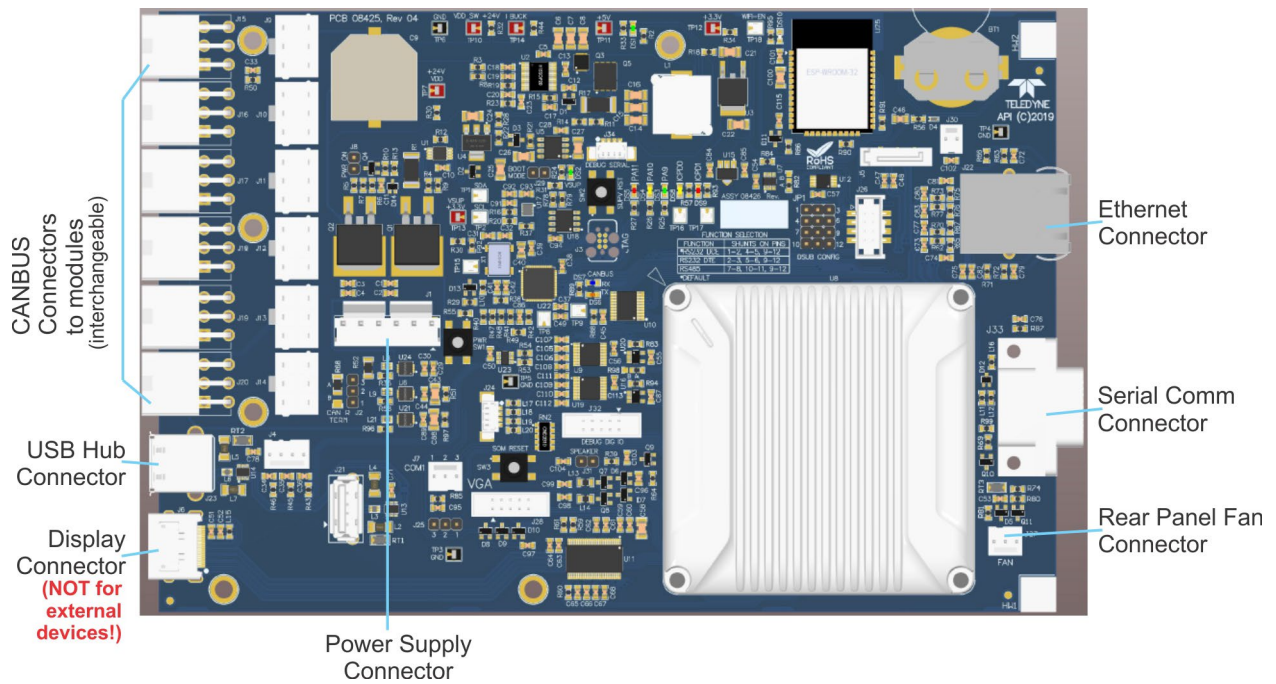

Figure 5-12. Mainboard Connectors

5.8.2.2 CONNECTORS ON DC PUMP PCA

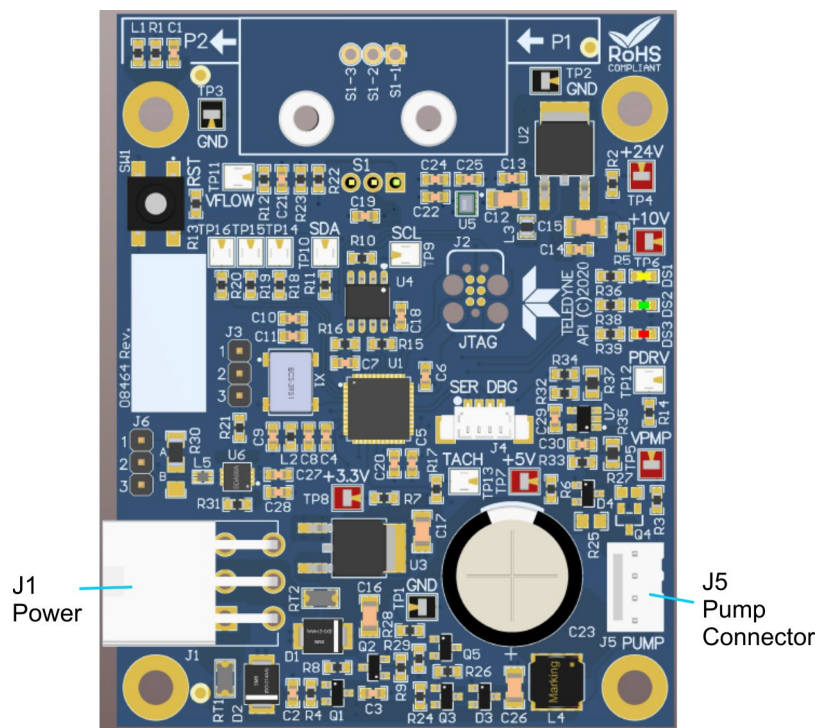

Figure 5-13. DC Pump Control Board Connectors



N300, N300M

5.8.2.3 CONNECTORS ON GFC SENSOR PCA

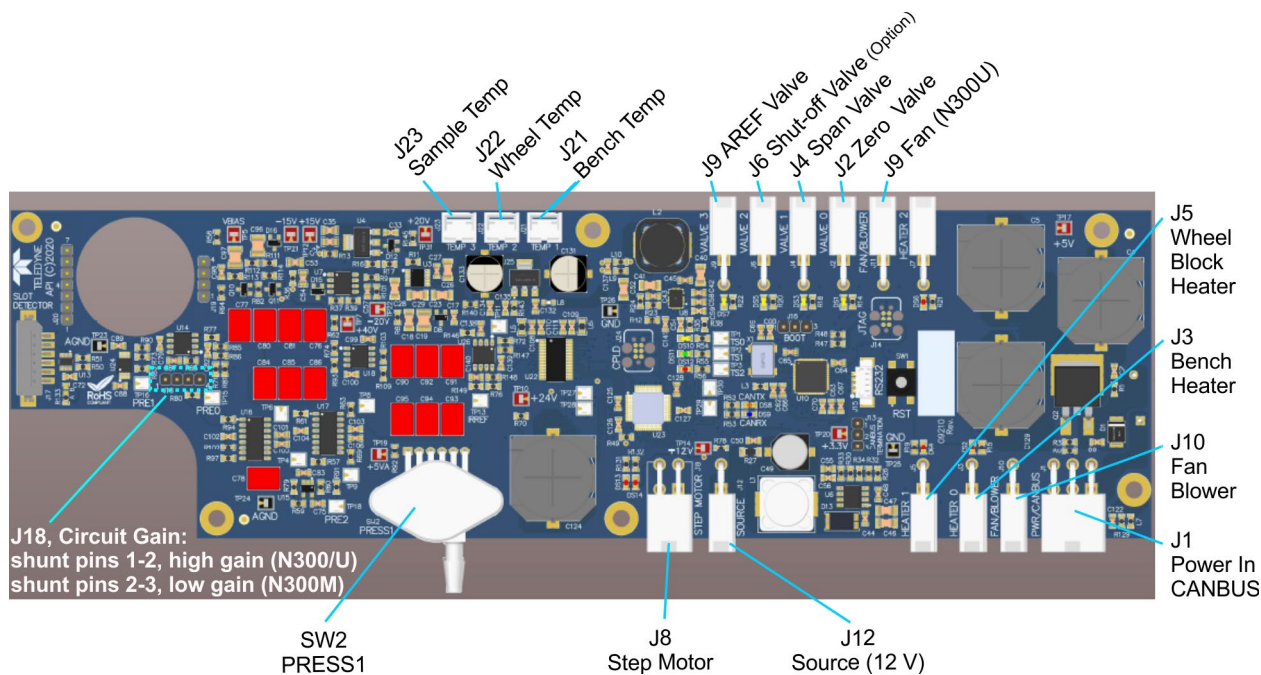

Figure 5-14. GFC Sensor Board Connectors

ATTENTION

COULD DAMAGE INSTRUMENT AND VOID WARRANTY
Never install or remove shunts while instrument is powered ON.

IMPORTANT

IMPACT ON READINGS OR DATA
Never swap Circuit Gain shunts: high gain is only for the N300 and N300U; low gain is only for the N300M.

5.8.3 REMOVING/REPLACING THE GFC WHEEL

When removing or replacing the GFC Wheel it is important to perform the disassembly in the following order to avoid damaging the components:

1. Turn off the analyzer.
2. Remove the top cover.
3. Open the instrument's hinged front panel.
4. Locate the GFC Wheel/motor assembly. See Figure 2-4.
5. Unplug the following electronic components:
 - The GFC Wheel housing temperature sensor (thermistor, Figure 5-15)
 - GFC Wheel heater
 - GFC Wheel motor power supply



N300, N300M

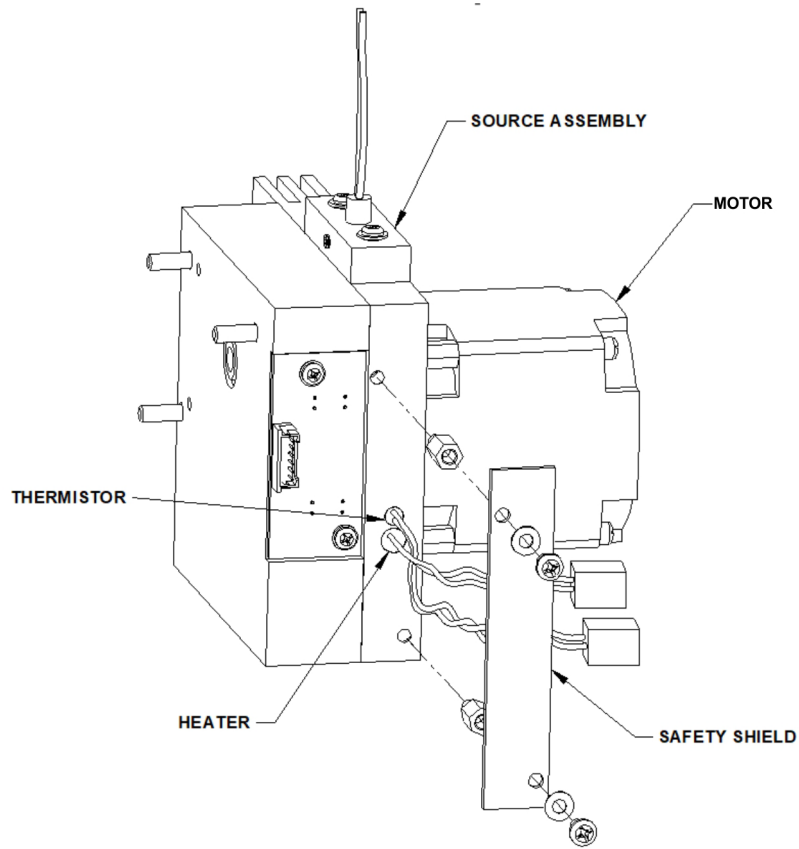

Figure 5-15. Opening the GFC Wheel Housing

6. Remove the two (2) screws holding the opto-pickup printed circuit assembly to the GFC Wheel housing.
7. Carefully remove the opto-pickup printed circuit assembly.



N300, N300M

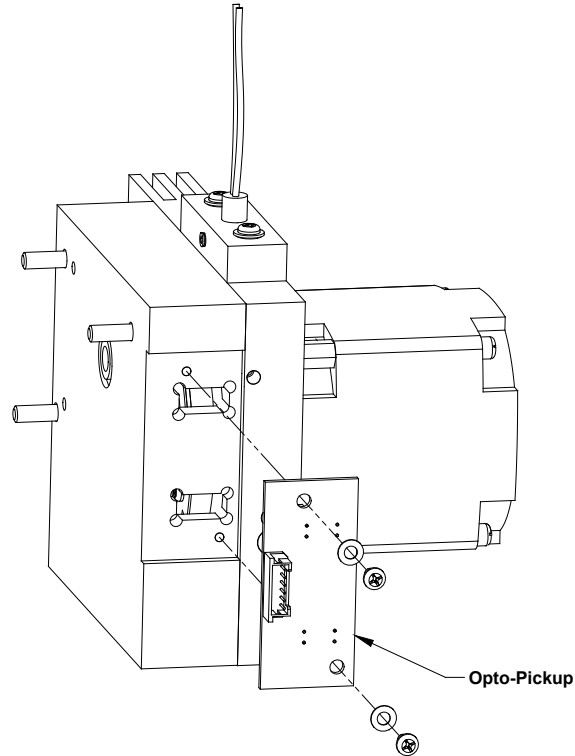

Figure 5-16. Removing the Opto-Pickup Assembly

8. Remove the three (3) screws holding the GFC Wheel motor/heat sink assembly to the GFC Wheel housing.
9. Carefully remove the GFC Wheel motor/heat sink assembly from the GFC Wheel housing.

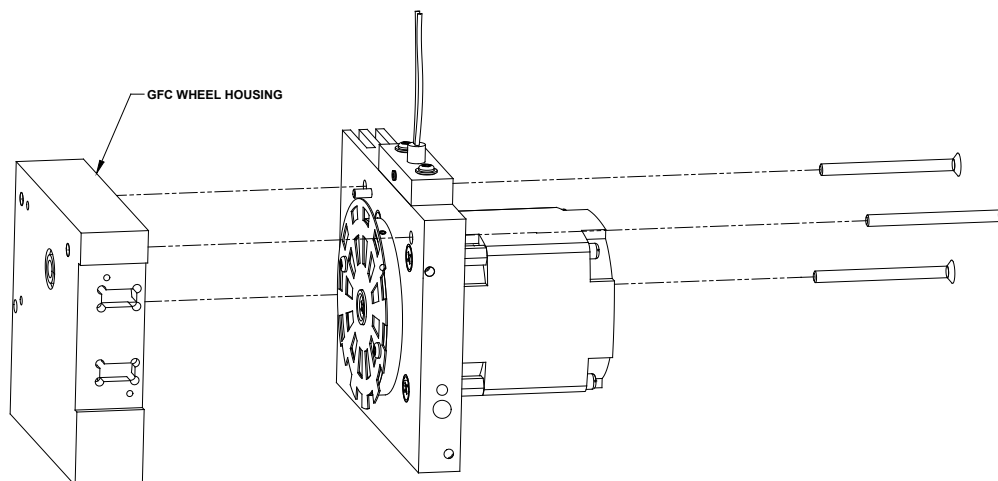

Figure 5-17. Removing the GFC Wheel Housing



N300, N300M

10. Remove the one (1) screw fastening the GFC Wheel/mask assembly to the GFC motor hub.

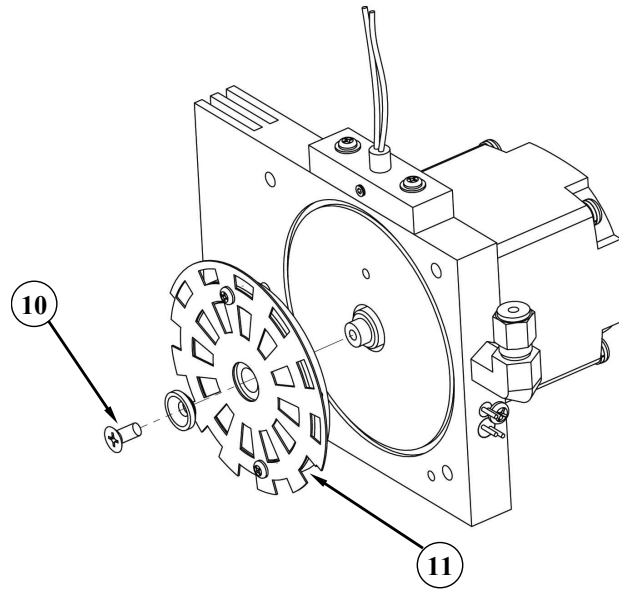

Figure 5-18. Removing the GFC Wheel

11. Remove the GFC Wheel/mask assembly.
12. Follow the previous steps in reverse order to put the GFC Wheel/motor assembly back together.

5.9 FREQUENTLY ASKED QUESTIONS

The following is a list from the Teledyne API's Technical Support Department of the most commonly asked questions relating to the N300/N300M CO Analyzer.

QUESTION	ANSWER
Why does the ENTR button sometimes disappear on the Front Panel Display?	<p>During certain types of adjustments or configuration operations, the ENTR button will disappear if you select a setting that is out of the allowable range for that parameter (such as trying to set the 24-hour clock to 25:00:00, or selecting a data logger hold off period of more than 20 minutes).</p> <p>Once you adjust the setting in question to an allowable value, the ENTR button will re-appear.</p>
Why is the ZERO or SPAN button not displayed during calibration?	<p>This happens when the measured gas concentration differs significantly from the span or zero gas concentration value entered by the user. This prevents accidental recalibration of the analyzer to an out-of-range response curve.</p> <p>EXAMPLE: The span set point is 40 ppm but gas concentration being measured is only 5 ppm.</p>



N300, N300M

QUESTION	ANSWER
	For more information, see Sections 5.7.6.3 and 5.7.6.4.
How do I enter or change the value of my Span Gas?	See Section 4.2.1.2.
Why does the analyzer not respond to span gas?	There could be something wrong with a span gas tank, or a span gas concentration was entered incorrectly, or there could be a pneumatic leak. Section 5.7.6.3 addresses these issues.
Is there an optional midpoint calibration?	<p>There is an optional mid-point linearity adjustment; however, midpoint adjustment is applicable only to applications where CO measurements are expected above 100 ppm.</p> <p>Call Teledyne API's Technical Support Department for more information on this topic.</p>
What do I do if the concentration displayed does not match the value recorded or displayed on my data logger even if both instruments are calibrated?	This most commonly occurs when an independent metering device is used besides the data logger/recorder to determine gas concentration levels while calibrating the analyzer. These disagreements result from the analyzer, the metering device and the data logger having slightly different ground levels.
How do I perform a leak check?	Section 5.6.3 provides leak check instructions.
How do I measure the sample flow?	Sample flow is measured by attaching a calibrated rotameter, wet test meter, or other flow-measuring device to the sample inlet port when the instrument is operating. The sample flow should be 800 cc/min \pm 10%. See Section 5.6.5.
How long does the IR source last?	Typical lifetime is about 2-3 years.
Can I automate calibration checks of my analyzer?	When zero/span valve or IZS options, the analyzer can be automatically calibration checked by using the AutoCal feature (Section 4.2.2.2).
Can I use the IZS option to calibrate the analyzer?	<p>Yes. However, whereas this may be acceptable for basic calibration checks, the IZS option is not as accurate as the external span and zero gas bottles.</p> <p>To achieve highest accuracy, it is recommended to use cylinders of calibrated span gases in combination with a zero air source.</p>
Q: What is the averaging time for an N300/N300M?	<p>A: The default averaging time, optimized for ambient pollution monitoring, is 150 seconds for stable concentrations and 10 seconds for rapidly changing concentrations (see Section 6.6.1 for more information).</p> <p>However, it is adjustable over a range of 0.5 second to 200 seconds (please contact Technical Support for more information).</p>



N300, N300M

5.10 TECHNICAL ASSISTANCE

If this manual and its troubleshooting / repair sections do not solve your problems, technical assistance may be obtained from:

Teledyne API Technical Support
9970 Carroll Canyon Road
San Diego, California 92131-1106 USA

Toll-free Phone: +1 800-324-5190

Phone: +1 858-657-9800

Fax: +1 858-657-9816

Email: api-techsupport@teledyne.com

Website: <http://www.teledyne-api.com/>

Before contacting Teledyne API Tech Support, please fill out the problem report form, available online for electronic submission at <http://www.teledyne-api.com>.



6. THEORY OF OPERATION

The N300/N300M Gas Filter Correlation Carbon monoxide Analyzer is a microprocessor-controlled analyzer that determines the concentration of carbon monoxide (CO) in a sample gas drawn through the instrument. It requires that the sample and calibration gases be supplied at ambient atmospheric pressure in order to establish a stable gas flow through the sample chamber where the gases ability to absorb infrared radiation is measured.

Calibration of the instrument is performed in software and does not require physical adjustments to the instrument. During calibration, the microprocessor measures the current state of the IR Sensor output and various other physical parameters of the instrument and stores them in memory.

The microprocessor uses these calibration values, the IR absorption measurements made on the sample gas along with data regarding the current temperature and pressure of the gas to calculate a final CO concentration.

This concentration value and the original information from which it was calculated are stored in the unit's internal data acquisition system (DAS).

6.1 MEASUREMENT METHOD

This Section presents measurement principles and fundamentals for this instrument.



6.1.1 BEER'S LAW

The basic principle by which the analyzer works is called the Beer-Lambert Law or Beer's Law. It defines how light of a specific wavelength is absorbed by a particular gas molecule over a certain distance. The mathematical relationship between these three parameters is:

$$I = I_0 e^{-\alpha Lc}$$

Equation 6-1

Where:

I_0 is the intensity of the light if there was no absorption.

I is the intensity with absorption.

e is the mathematical constant (Euler's number)

L is the absorption path, or the distance the light travels as it is being absorbed.

C is the concentration of the absorbing gas (in the case of the N300/N300M, Carbon Monoxide (CO)).

α is the absorption coefficient that tells how well CO absorbs light at the specific wavelength of interest.

6.2 MEASUREMENT FUNDAMENTALS

In the most basic terms, the analyzer uses a high-energy heated element to generate a beam of broad-band IR light with a known intensity (measured during instrument calibration). This beam is directed through a multi-pass cell filled with sample gas. The sample cell uses mirrors at each end to reflect the IR beam back and forth through the sample gas a number of times (see Figure 6-1) to generate a long absorption path.

The total length that the reflected light travels is directly related to the intended sensitivity of the instrument. The lower the concentrations the instrument is designed to detect, the longer the light path must be in order to create detectable levels of attenuation.

Lengthening the absorption path is accomplished partly by making the physical dimension of the reaction cell longer, but primarily by adding extra passes back and forth along the length of the chamber.

Table 6-1. Absorption Path Length

MODEL	TOTAL NUMBER OF REFLECTIVE PASSES	DISTANCE BETWEEN MIRRORS	TOTAL ABSORPTION LIGHT PATH
N300	32	437.5 mm	14 Meters
N300M	8	312.5 mm	2.5 Meters

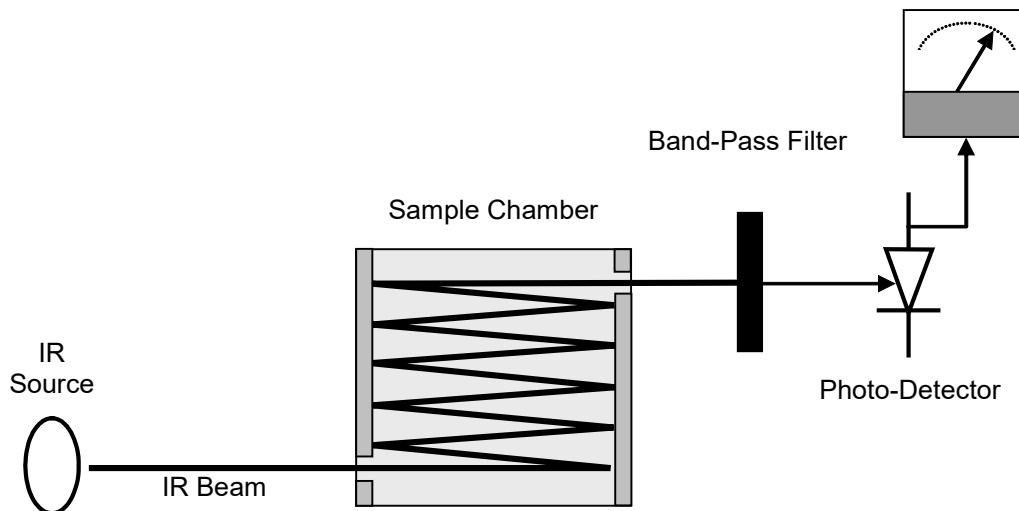

Figure 6-1. IR Beam Path

Upon exiting the sample cell, the beam shines through a band-pass filter that allows only light at a wavelength of 4.7 μm to pass. Finally, the beam strikes a solid-state photo-detector that converts the light signal into a modulated voltage signal representing the attenuated intensity of the beam.

6.2.1 GAS FILTER CORRELATION

Because water vapor also absorbs light at 4.7 μm , a Gas Filter Correlation (GFC) Wheel is added to the IR light path to overcome the interfering effects of water vapor.

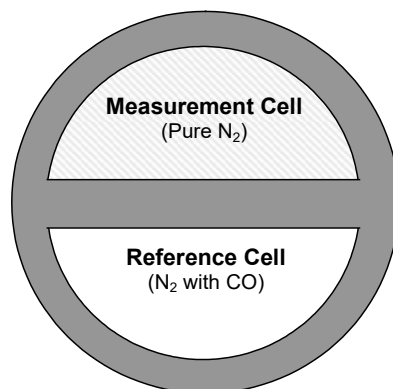

Figure 6-2. GFC Wheel

6.2.1.1 THE GFC WHEEL

A GFC Wheel is a metallic wheel into which two chambers are carved. The chambers are sealed on both sides with material transparent to 4.7 μm IR radiation creating two airtight cavities. Each cavity is mainly filled with composed gases. One cell is filled with pure N_2 (the measurement cell). The other is filled with a combination of N_2 and a high concentration of CO (the reference cell).

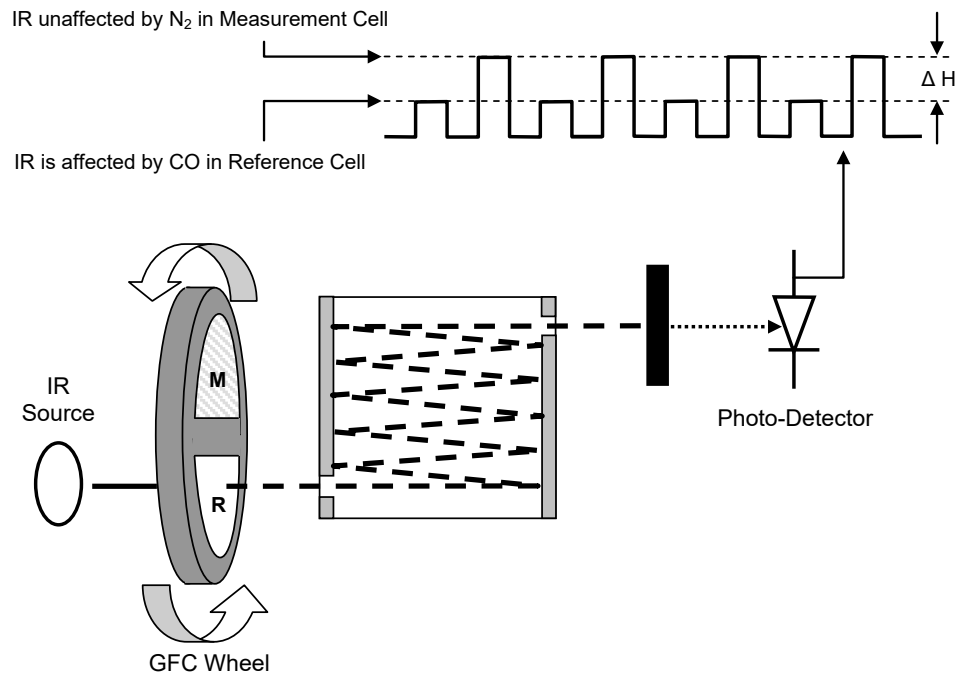

Figure 6-3. Measurement Fundamentals with GFC Wheel

As the GFC Wheel spins, the IR light alternately passes through the two cavities. When the beam is exposed to the reference cell, the CO in the gas filter wheel strips the beam of most of the IR at $4.7\mu\text{m}$. When the light beam is exposed to the measurement cell, the N_2 in the filter wheel does not absorb IR light. This causes a fluctuation in the intensity of the IR light striking the photo-detector which results in the output of the detector resembling a square wave.

6.2.1.2 THE MEASURE/REFERENCE (M/R) RATIO

The analyzer determines the amount of CO in the sample chamber by computing the ratio between the peak of the measurement pulse (IR Measure) and the peak of the reference pulse (IR Reference).

If no gases exist in the sample chamber that absorb light at $4.7\mu\text{m}$, the high concentration of CO in the gas mixture of the reference cell will attenuate the intensity of the IR beam by 60% giving a M/R ratio of approximately 2.4:1.

Adding CO to the sample chamber causes the peaks corresponding to both cells to be attenuated by a further percentage. Since the intensity of the light passing through the measurement cell is greater, the effect of this additional attenuation is greater. This causes IR Measure to be more sensitive to the presence of CO in the sample chamber than IR Reference and the ratio between them (M/R) to move closer to 1:1 as the concentration of CO in the sample chamber increases.

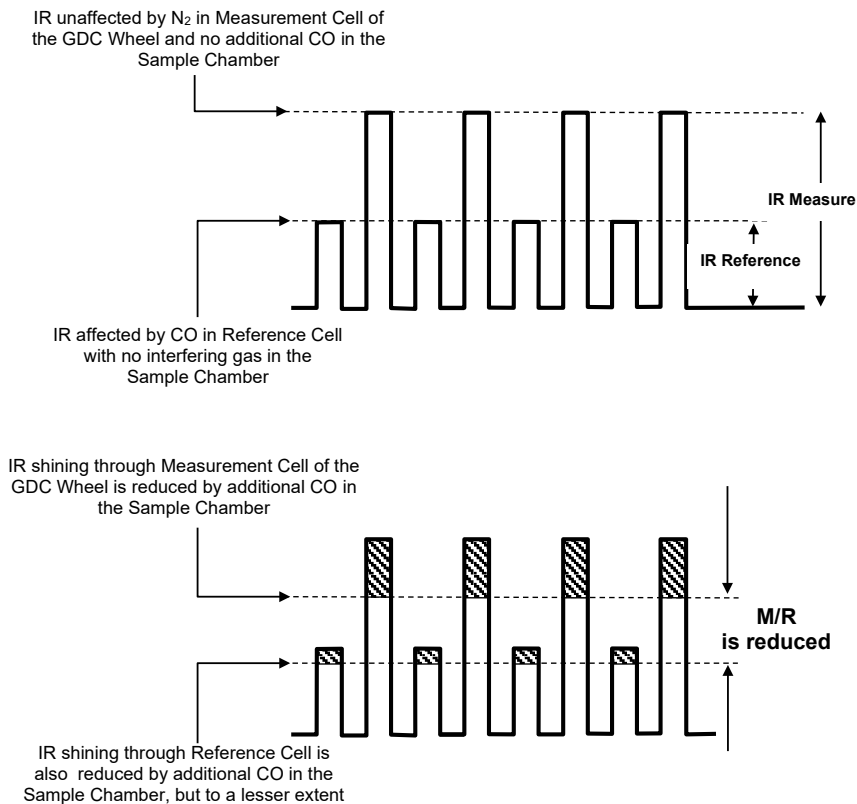

Figure 6-4. Effect of CO in the Sample on IR Measure & IR Reference

Once the analyzer has computed this ratio, a look-up table is used, with interpolation, to linearize the response of the instrument. This linearized concentration value is combined with calibration SLOPE and OFFSET values to produce the CO concentration which is then normalized for changes in sample pressure.

6.2.1.3 INTERFERENCE AND SIGNAL TO NOISE REJECTION

If an interfering gas, such as H₂O vapor is introduced into the sample chamber, the spectrum of the IR beam is changed in a way that is identical for both the reference and the measurement cells, but without changing the ratio between the peak heights of IR Measure and IR Reference. In effect, the difference between the peak heights remains the same.

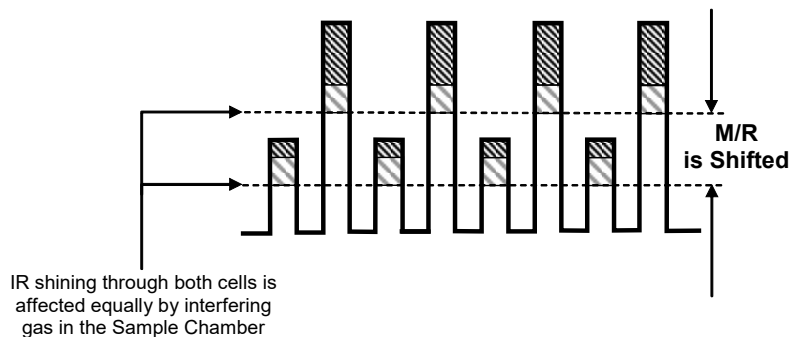

Figure 6-5. Effects of Interfering Gas on IR Measure and IR Reference

Thus, the difference in the peak heights and the resulting M/R Ratio is only due to CO and not to interfering gases. In this case, GFC rejects the effects of interfering gases and so that the analyzer responds only to the presence of CO.

To improve the signal-to-noise performance of the IR photo-detector, the GFC Wheel also incorporates an optical mask that chops the IR beam into alternating pulses of light and dark at six times the frequency of the measure/reference signal. This limits the detection bandwidth helping to reject interfering signals from outside this bandwidth improving the signal to noise ratio.

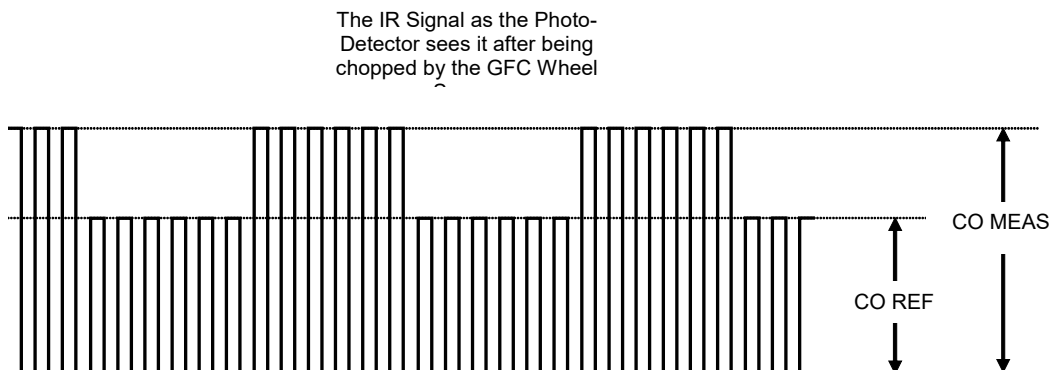

Figure 6-6. Chopped IR Signal

6.2.1.4 SUMMARY INTERFERENCE REJECTION

The basic design of the N300/N300M rejects most of this interference at a 300:1 ratio. The two primary methods used to accomplish this are:

- The 4.7 μ m band pass filter just before the IR sensor which allows the instrument to only react to IR absorption in the wavelength affected by CO.
- Comparison of the measure and reference signals and extraction of the ratio between them.

6.3 OXYGEN SENSOR (OPTION)

6.3.1 PARAMAGNETIC MEASUREMENT OF O₂

The oxygen sensor measures O₂ based in the science that oxygen is attracted into strong magnetic field; most other gases are not, to obtain fast, accurate oxygen measurements.

The sensor's core is made up of two nitrogen filled glass spheres, which are mounted on a rotating suspension within a magnetic field (Figure 6-7). A mirror is mounted centrally on the suspension, and light is shone onto the mirror that reflects the light onto a pair of photocells. The signal generated by the photocells is passed to a feedback loop, which outputs a current to a wire winding (in effect, a small DC electric motor) mounted on the suspended mirror.

Oxygen from the sample stream is attracted into the magnetic field displacing the nitrogen filled spheres and causing the suspended mirror to rotate. This changes the amount of light reflected onto the photocells and therefore the output levels of the



N300, N300M

photocells. The feedback loop increases the amount of current fed into the winding in order to move the mirror back into its original position. The more O₂ present, the more the mirror moves and the more current is fed into the winding by the feedback control loop.

A sensor measures the amount of current generated by the feedback control loop which is directly proportional to the concentration of oxygen within the sample gas mixture.

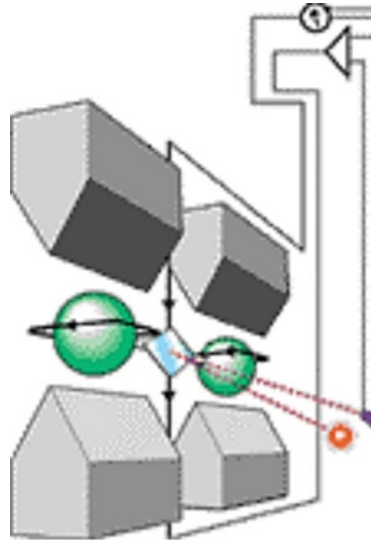

Figure 6-7. Oxygen Sensor - Principle of Operation

6.3.1.1 O₂ SENSOR OPERATION WITHIN THE ANALYZER

The oxygen sensor option is transparently integrated into the core analyzer operation. Its parameters and functions are accessed through the same menu system as the CO₂ Sensor.

The O₂ concentration range is 0-100% (user selectable) with 0.1% precision and accuracy and is available to be output via the instrument's analog output (see Section 2.5.8).

The temperature of the O₂ sensor is maintained at a constant 50° C through a PID loop.

The O₂ sensor assembly itself does not have any serviceable parts and is enclosed in an insulated canister.

6.4 PNEUMATIC OPERATION



CAUTION – General Safety Hazard

It is important that the sample airflow system is both leak tight and not pressurized over ambient pressure.

Regular leak checks should be performed on the analyzer as described in the maintenance schedule, Table 5-1. Leak check procedures can be found in Section 5.6.3.

Figure 2-15 in Section 2.3.3.1 illustrates the pneumatic path in the basic configuration. An internal pump evacuates the sample chamber creating a small vacuum that draws sample gas into the analyzer. Normally the analyzer is operated with its inlet near



N300, N300M

ambient pressure either because the sample is directly drawn at the inlet or a small vent is installed at the inlet. There are several advantages to this “pull through” configuration. By placing the pump down stream from the sample chamber several problems are avoided:

- First, the pumping process heats and compresses the sample air complicating the measurement process.
- Additionally, certain physical parts of the pump itself are made of materials that might chemically react with the sample gas.
- Finally, in certain applications where the concentration of the target gas might be high enough to be hazardous, maintaining a negative gas pressure relative to ambient means that no sample gas will be pumped into the atmosphere surrounding analyzer in the event of a leak.

6.4.1 FLOW RATE CONTROL

The HD non-PID controlled pump option (Figure 5-9) maintains a constant flow rate of the sample gas through the instrument, using:

- A critical flow orifice.
- Two o-rings: Located just before and after the critical flow orifice, the o-rings seal the gap between the walls of assembly housing and the critical flow orifice.
- A spring: Applies mechanical force needed to form the seal between the o-rings, the critical flow orifice and the assembly housing.

The STD PID controlled pump option (Figure 5-10) runs on a PID loop flow control that requires no orifice.

6.4.1.1 CRITICAL FLOW ORIFICE

The most important component of the HD non-PID flow control assembly is the critical flow orifice.

Critical flow orifices are a remarkably simple way to regulate stable gas flow rates. They operate without moving parts by taking advantage of the laws of fluid dynamics. By restricting the flow of gas through the orifice, a pressure differential is created. This pressure differential combined with the action of the analyzer’s pump draws the gas through the orifice.

As the pressure on the downstream side of the orifice (the pump side) continues to drop, the speed that the gas flows through the orifice continues to rise. Once the ratio of upstream pressure to downstream pressure is greater than 2:1, the velocity of the gas through the orifice reaches the speed of sound. As long as that ratio stays at least 2:1, the gas flow rate is unaffected by any fluctuations, surges, or changes in downstream pressure because such variations only travel at the speed of sound themselves and are therefore cancelled out by the sonic shockwave at the downstream exit of the critical flow orifice.

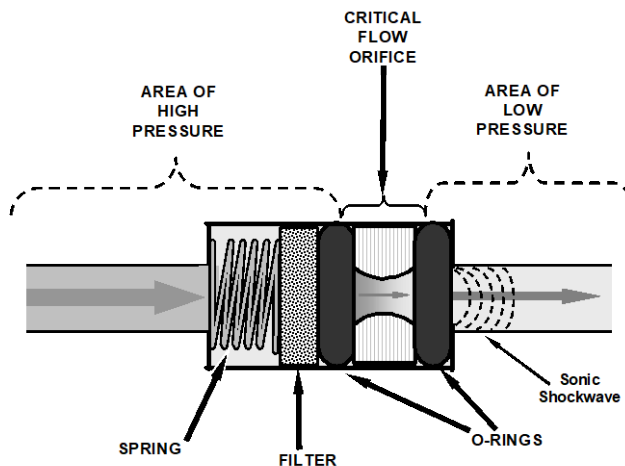

Figure 6-8. Flow Control Assembly & Critical Flow Orifice

The actual flow rate of gas through the orifice (volume of gas per unit of time), depends on the size and shape of the aperture in the orifice. The larger the hole, the more the gas molecules move at the speed of sound and pass through the orifice. Because the flow rate of gas through the orifice is only related to the minimum 2:1 pressure differential and not absolute pressure, the flow rate of the gas is also unaffected by degradations in pump efficiency due to age.

The critical flow orifice used in the analyzer is designed to provide a flow rate per specification (Table 1-1).

6.4.2 PARTICULATE FILTER

The analyzer can be equipped with either a 47 mm diameter Teflon particulate filter with a 5 micron pore size or a long-life DFU filter with 0.01 micron pore size. The filter is accessible through the hinged rear panel, which folds down to allow access, and should be changed according to the suggested maintenance schedule described in Table 5-1.

6.4.3 PNEUMATIC SENSORS

The pneumatic sensors measure sample pressure and flow.

6.4.3.1 SAMPLE PRESSURE SENSOR

An absolute value pressure transducer plumbed to the outlet of the sample chamber is used to measure sample pressure. The output of the sensor is used to compensate the concentration measurement for changes in air pressure.

6.4.3.2 SAMPLE FLOW SENSOR

A thermal-mass flow sensor is used to measure the sample flow through the analyzer. The sensor is calibrated at the factory with ambient air or N₂, but can be calibrated to operate with samples consisting of other gases such as CO.



6.5 ELECTRONIC OPERATION

The electronic platform is based on a Controller Area Network (CAN) bus modular system. CAN is the central networking system that enables communication among all the parts and facilitates centralized diagnoses of errors, as well as configuration of all the parts. CAN bus technology allows for a uniform cable architecture with interchangeable 6-pin connectors configured for power (5 V and 24 V) and communications (CAN high and CAN low serial lines).

The Mainboard is the main hub, which not only contains the Central Processing Unit (CPU) that communicates with other modules, but also directs power and communication distribution. The Mainboard includes an atmospheric pressure sensor, a temperature sensor, and the Supervisory Chip.

The Supervisory Chip monitors power and the sensors, and when the front panel Soft Power switch is pressed (see Power Switches, Section 6.5.2), the Supervisory Chip directs the soft power down of the internal components.

6.5.1 MODULES

Each module consists of its own board controlled by a microprocessor that receives messages from and sends information to the Mainboard on the CAN network. Depending on the signal line, CAN Low or CAN High, the modules can determine whether a message is intended for them and what the priority is, and then act on the applicable messages. These are called “Smart Modules,” which conduct local operations, such as activating valves or controlling manifold temperature. There is also the Sensor Module, which is comprised of the gas sensor and its operational components, as well as the data acquisition (DAQ) board with logic device, microcontroller and LED driver mounted on it. The Sensor Module calculates gas concentrations and may command the Smart Modules.

6.5.2 POWER SWITCHES

The front panel Soft Power switch is used to protect against data loss. When the instrument is initially powered on, the Supervisory Chip spins up the internal computer components and places them in operational mode (indicated by LED’s solid-lit state). However, before powering off the instrument, pressing and momentarily holding the solid-lit Soft Power switch tells the Supervisory Chip to put the internal computer components through a soft-shutdown process (indicated by LED’s blinking state).

The rear panel Hard Power switch is used to turn on or off the instrument; however, before turning off the instrument, the Soft Power switch must be used first as described above. If there is an unexpected loss of source power while the instrument is running, it will power up in the ON state when source power is restored.

6.5.3 OPTICAL BENCH & GFC WHEEL

Electronically, in the case of the optical bench for the N300 Analyzer, GFC Wheel and associated components do more than simply measure the amount of CO present in the sample chamber. A variety of other critical functions are performed here as well.



N300, N300M

6.5.3.1 TEMPERATURE CONTROL

Because the temperature of a gas affects its density resulting in the amount of light absorbed by that gas, it is important to reduce the effect of fluctuations in ambient temperature on the measurement of CO for the analyzer. To accomplish this both the temperature of the sample chamber and the GFC Wheel are maintained at constant temperatures above their normal operating ranges.

BENCH TEMPERATURE

To minimize the effects of ambient temperature variations on the sample measurement, the sample chamber is heated to 48°C (8 degrees above the maximum suggested ambient operating temperature for the analyzer). A strip heater attached to the underside of the chamber housing is the heat source. The temperature of the sample chamber is sensed by a thermistor, also attached to the sample chamber housing.

WHEEL TEMPERATURE

To minimize the effects of temperature variations caused by the near proximity of the IR Source to the GFC Wheel on the gases contained in the wheel, it is also raised to a high temperature level. Because the IR Source itself is very hot, the set point for this heat circuit is 68°C. A cartridge heater implanted into the heat sync on the motor is the heat source. The temperature of the wheel/motor assembly is sensed by a thermistor also inserted into the heat sync.

Both heaters operate off 24VDC.

6.5.3.2 IR SOURCE

The light used to detect CO in the sample chamber is generated by an element heated to approximately 1100°C producing infrared radiation across a broad band. This radiation is optically filtered after it has passed through the GFC Wheel and the sample chamber and just before it reaches the photo-detector to eliminate all black body radiation and other extraneous IR emitted by their various components.



6.5.3.3 GFC WHEEL

A DC stepper motor turns the GFC Wheel motor at rates that vary as needed at XXX rpm. The actual spin rate is unimportant within a large range since a phase lock loop circuit is used to generate timing pulses for signal processing.

In order to accurately interpret the fluctuations of the IR beam after it has passed through the sample gas, the GFC Wheel's several other timing signals are produced by other photo emitters/detectors. These devices consist of a combination LED and detector mounted so that the light emitted by the LED shines through the same mask on the GFC Wheel that chops the IR beam.

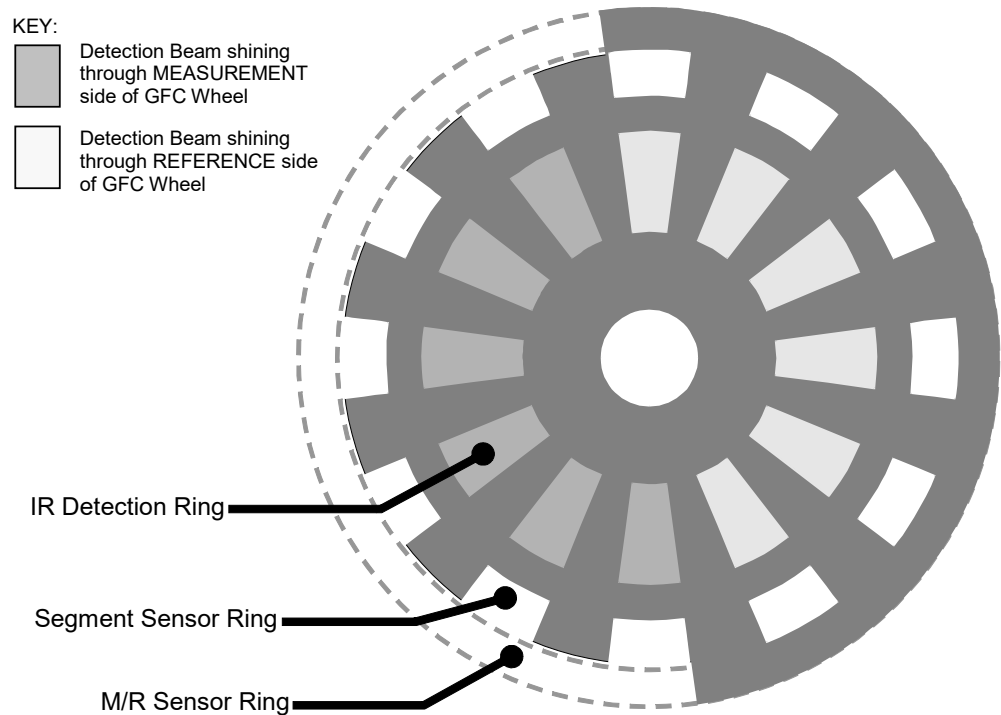

Figure 6-9. GFC Light Mask

M/R SENSOR

This emitter/detector assembly produces a signal that shines through a portion of the mask that allows light to pass for half of a full revolution of the wheel. The resulting light signal tells the analyzer whether the IR beam is shining through the measurement or the reference side of the GFC Wheel.



N300, N300M

SEGMENT SENSOR

Light from this emitter/detector pair shines through a portion of the mask that is divided into the same number of segments as the IR detector ring. It is used by the synchronous/demodulation circuitry of the analyzer to latch onto the most stable part of each measurement and reference IR pulse.

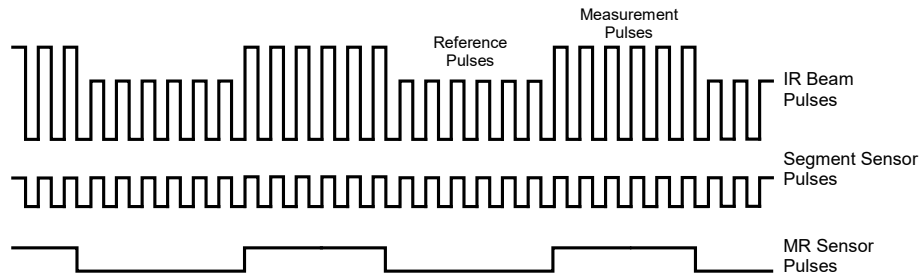

Figure 6-10. Segment Sensor and M/R Sensor Output

SCHMIDT TRIGGERS

To ensure that the waveforms produced by the Segment Sensor and the M/R Sensor are properly shaped and clean, these signals are passed through a set of Schmidt Triggers circuits.

6.5.3.4 IR PHOTO-DETECTOR

The IR beam is converted into an electrical signal by a cooled solid-state photo-conductive detector. The detector is composed of a narrow-band optical filter, a piece of lead-salt crystal whose electrical resistance changes with temperature, and a two-stage thermo-electric cooler.

When the analyzer is on, a constant electrical current is directed through the detector. The IR beam is focused onto the detector surface, raising its temperature and lowering its electrical resistance that results in a change in the voltage drop across the detector.

During those times that the IR beam is bright, the temperature of the detector is high; the resistance of the detector is correspondingly low and its output voltage output is low. During those times when the IR beam intensity is low or completely blocked by the GFC Wheel mask, the temperature of the detector is lowered by the two-stage thermo-electric cooler, increasing the detector's resistance and raising the output voltage.

6.6 SOFTWARE OPERATION

The N300/N300M Gas Filter Correlation Carbon Monoxide Analyzer uses special software developed by Teledyne API, which interprets user commands via the various interfaces, performs procedures and tasks, stores data in memory and calculates the concentration of the sample gas.



6.6.1 ADAPTIVE FILTER FOR STABILITY

The software processes the measurement and reference signals through an adaptive filter built into the software. Rather than averaging the output signal over a fixed time period, the analyzer averages over a set number of samples, each sample being 0.2 seconds. This technique is known as boxcar averaging. During operation, the software automatically switches between two different length filters based on the conditions at hand. Once triggered, the short filter remains engaged for a fixed time period to prevent chattering.

During conditions of constant or nearly constant concentration the software, by default, computes an average of the last 800 samples, or approximately 160 seconds. This provides the calculation portion of the software with smooth stable readings. If a rapid change in concentration is detected, the filter includes the last 30 samples (~6 seconds of data), allowing the analyzer to more quickly respond. If necessary, these boxcar lengths can be changed between 1 and 1000 samples but with corresponding tradeoffs in rise time and signal-to-noise ratio (contact Technical Support for more information).

Two conditions must be simultaneously met to switch to the short filter. First, the instantaneous concentration must exceed the average in the long filter by a fixed amount. Second, the instantaneous concentration must exceed the average in the long filter by a portion, or percentage, of the average in the long filter.

6.6.2 CALIBRATION - SLOPE AND OFFSET

During instrument calibration (see Section 4) the user enters expected values for zero and span via the control interface, commanding the instrument to make readings of calibrated sample gases for both levels. The readings taken are adjusted, linearized, and compared to the expected values. With this information the software computes values for instrument slope and offset and stores these values in memory for use in calculating the CO concentration of the sample gas. Configure the Dashboard (Setup>Dashboard) to display the instrument slope and offset values recorded during the last calibration.

6.6.3 MEASUREMENT ALGORITHM

The analytical software calculates the ratio between IR Measure and IR Reference (Section 6.2.1.1). This value is compared to a look-up table that is used, with interpolation, to linearize the response of the instrument. The linearized concentration value is combined with calibration slope and offset values, then normalized for changes in sample gas pressure to produce the final CO concentration. This is the value that is displayed on the instrument front panel display and is stored in memory by the analyzer's data acquisition system (DAS), the Data Logger.

6.6.4 TEMPERATURE AND PRESSURE COMPENSATION (TPC)

Changes in pressure can have a noticeable effect on the CO concentration calculation. To account for this, the software includes a feature which allows the instrument to compensate for the CO calculations based on changes in ambient pressure.

This TPC feature multiplies the analyzer's CO concentration by a factor that is based on the difference between the ambient pressure of the sample gas normalized to standard atmospheric pressure. As ambient pressure increases, the compensated CO concentration is decreased.



GLOSSARY

Note: Some terms in this glossary may not occur elsewhere in this manual.

TERM	DESCRIPTION/DEFINITION
10Base-T	an Ethernet standard that uses twisted (“T”) pairs of copper wires to transmit at 10 megabits per second (Mbps)
100Base-T	same as 10BaseT except ten times faster (100 Mbps)
APICOM	name of a remote control program offered by Teledyne-API to its customers
ASSY	<i>Assembly</i>
CAS	<i>Code-Activated Switch</i>
CD	<i>Corona Discharge</i> , a frequently luminous discharge, at the surface of a conductor or between two conductors of the same transmission line, accompanied by ionization of the surrounding atmosphere and often by a power loss
CE	<i>Converter Efficiency</i> , the percentage of light energy that is actually converted into electricity
CEM	<i>Continuous Emission Monitoring</i>
Chemical formulas that may be included in this document:	
CO ₂	carbon dioxide
C ₃ H ₈	propane
CH ₄	methane
H ₂ O	water vapor
HC	general abbreviation for hydrocarbon
HNO ₃	nitric acid
H ₂ S	hydrogen sulfide
NO	nitric oxide
NO ₂	nitrogen dioxide
NO _x	nitrogen oxides, here defined as the sum of NO and NO ₂
NO _y	nitrogen oxides, often called odd nitrogen: the sum of NO _x plus other compounds such as HNO ₃ (definitions vary widely and may include nitrate (NO ₃), PAN, N ₂ O and other compounds as well)
NH ₃	ammonia
O ₂	molecular oxygen
O ₃	ozone
SO ₂	sulfur dioxide
cc	metric abbreviation for <i>cubic centimeter</i>
CPU	<i>Central Processing Unit</i>
DAC	<i>Digital-to-Analog Converter</i>
DAS	<i>Data Acquisition System</i>
DCE	<i>Data Communication Equipment</i>
DFU	<i>Dry Filter Unit</i>
DHCP	<i>Dynamic Host Configuration Protocol</i> . A protocol used by LAN or Internet servers to automatically set up the interface protocols between themselves and any other addressable device connected to the network
DIAG	<i>Diagnostics</i> , the diagnostic settings of the analyzer.
DOM	<i>Disk On Module</i> , a 44-pin IDE flash drive with up to 128MB storage capacity for instrument’s firmware, configuration settings and data
DRAM	<i>Dynamic Random Access Memory</i>



N300, N300M

TERM	DESCRIPTION/DEFINITION
DTE	<i>Data Terminal Equipment</i>
EEPROM	<i>Electrically Erasable Programmable Read-Only Memory</i> also referred to as a FLASH chip or drive
ESD	<i>Electro-Static Discharge</i>
Ethernet	a standardized (IEEE 802.3) computer networking technology for local area networks (LANs), facilitating communication and sharing resources
FEP	<i>Fluorinated Ethylene Propylene</i> polymer, one of the polymers that Du Pont markets as <i>Teflon</i> [®]
Flash	non-volatile, solid-state memory
FPI	<i>Fabry-Perot Interface</i> : a special light filter typically made of a transparent plate with two reflecting surfaces or two parallel, highly reflective mirrors
GFC	<i>Gas Filter Correlation</i>
I ² C bus	a clocked, bi-directional, serial bus for communication between individual analyzer components
IC	<i>Integrated Circuit</i> , a modern, semi-conductor circuit that can contain many basic components such as resistors, transistors, capacitors etc in a miniaturized package used in electronic assemblies
IP	<i>Internet Protocol</i>
IZS	<i>Internal Zero Span</i>
LAN	<i>Local Area Network</i>
LCD	<i>Liquid Crystal Display</i>
LED	<i>Light Emitting Diode</i>
LPM	<i>Liters Per Minute</i>
MFC	<i>Mass Flow Controller</i>
M/R	<i>Measure/Reference</i>
MOLAR MASS	the mass, expressed in grams, of 1 mole of a specific substance. Conversely, one mole is the amount of the substance needed for the molar mass to be the same number in grams as the atomic mass of that substance. EXAMPLE: The atomic weight of Carbon is 12 therefore the molar mass of Carbon is 12 grams. Conversely, one mole of carbon equals the amount of carbon atoms that weighs 12 grams. Atomic weights can be found on any Periodic Table of Elements.
NDIR	<i>Non-Dispersive Infrared</i>
NIST-SRM	<i>National Institute of Standards and Technology - Standard Reference Material</i>
PC	<i>Personal Computer</i>
PCA	<i>Printed Circuit Assembly</i> , the PCB with electronic components, ready to use
PCB	<i>Printed Circuit Board</i> , the bare board without electronic component
PFA	<i>Perfluoroalkoxy</i> , an inert polymer; one of the polymers that <i>Du Pont</i> markets as <i>Teflon</i> [®]
PLC	<i>Programmable Logic Controller</i> , a device that is used to control instruments based on a logic level signal coming from the analyzer
PLD	<i>Programmable Logic Device</i>
PLL	<i>Phase Lock Loop</i>
P/N (or PN)	<i>Part Number</i>
PSD	<i>Prevention of Significant Deterioration</i>
PTFE	<i>Polytetrafluoroethylene</i> , a very inert polymer material used to handle gases that may react on other surfaces; one polymer that <i>Du Pont</i> markets as <i>Teflon</i> [®]
PVC	<i>Poly Vinyl Chloride</i> , a polymer used for downstream tubing



N300, N300M

TERM	DESCRIPTION/DEFINITION
RS-232	specification and standard describing a serial communication method between DTE (Data Terminal Equipment) and DCE (Data Circuit-terminating Equipment) devices, using a maximum cable-length of 50 feet
RS-485	specification and standard describing a binary serial communication method among multiple devices at a data rate faster than RS-232 with a much longer distance between the host and the furthest device
SAROAD	<i>Storage and Retrieval of Aerometric Data</i>
SLAMS	<i>State and Local Air Monitoring Network Plan</i>
SLPM	<i>Standard Liters Per Minute</i> of a gas at standard temperature and pressure
STP	<i>Standard Temperature and Pressure</i>
TCP/IP	<i>Transfer Control Protocol / Internet Protocol</i> , the standard communications protocol for Ethernet devices
TPC	<i>Temperature/Pressure Compensation</i>
USB	<i>Universal Serial Bus</i> : a standard connection method to establish communication between peripheral devices and a host controller, such as a mouse and/or keyboard and a personal computer or laptop
VARs	<i>Variables</i> , the variable settings of the instrument
V-F	<i>Voltage-to-Frequency</i>
Z/S	<i>Zero / Span</i>



N300, N300M

APPENDIX A – MODBUS REGISTERS

ADDRESS	TAG	DESCRIPTION
Discrete Inputs		
0	SYS_WARN_SOURCE_WARNING	Reference detector reading is outside set value range.
2	BENCH_TEMP_WARN	Bench temperature is out of range.
3	WHEEL_TEMP_WARN	Wheel temperature is out of range
7	SYS_WARN_RESET	CPU has rebooted
8	SYS_WARN_SUPERVISOR_COM_WARNING	Supervisor communication warning when module watchdog timer has expired
9	SYS_WARN_GFC_COM_WARNING	GFC module watchdog timer has expired
10	SYS_WARN_PUMP_CONTROL_COM_WARNING	Pump control module watchdog expired
11	SYS_WARN_ANALOG_OUTPUT_COM_WARNING	Analog output module watchdog expired
12	SYS_WARN_DIGITAL_IO_COM_WARNING	Digital I/O module watchdog expired
13	LOW_MEMORY_WARNING	Memory running low
14	SYS_INVALID_CONC_WARNING	Concentration reading is out of range
18	SYS_OK_WARN	Denotes whether fault is present in system
19	SYS_WARN_AO_OUTPUT1_CAL	Analog Output channel 1 requires calibration
20	SYS_WARN_AO_OUTPUT2_CAL	Analog Output channel 2 requires calibration
21	SYS_WARN_AO_OUTPUT3_CAL	Analog Output channel 3 requires calibration
22	SYS_WARN_AO_OUTPUT4_CAL	Analog Output channel 4 requires calibration
23	SYS_WARN_AO_OUTPUT5_CAL	Analog Output channel 5 requires calibration
24	SYS_WARN_AO_OUTPUT6_CAL	Analog Output channel 6 requires calibration
25	SYS_WARN_AO_OUTPUT7_CAL	Analog Output channel 7 requires calibration
26	SYS_WARN_TIME_NOT_SYNCED	Network server time not synchronized
Coils		
20	MB_ZERO_CAL_RANGE1	Enable/disable external zero cal range 1
21	MB_SPAN_CAL_RANGE1	Enable/disable external span cal range 2
22	MB_ZERO_CAL_RANGE2	Enable/disable external zero cal range 2
23	MB_SPAN_CAL_RANGE2	Enable/disable external span cal range 2
Input Registers		
0	AI_IR_MEASURE	Photometer Detector Measure Reading in mV
2	AI_IR_REFERENCE	Photometer Detector Reference Reading in mV
4	MR_RATIO	Measure Over Reference ratio
6	CO_SLOPE1	Slope for range 1
8	CO_SLOPE2	Slope for range 2
10	CO_OFFSET1	Offset for range 1
12	CO_OFFSET2	Offset for range 2
18	CO_CONC	CO conc for range 1
20	CO_CONC_2	CO conc for range 2
22	CO_STABILITY	Conc stability
24	AI_BENCH_TEMP	Bench temperature in degree C
26	AI_BENCH_DUTY_CYCLE	Bench temperature control duty cycle
28	AI_WHEEL_TEMP	Wheel temperature in degree C
30	AI_WHEEL_DUTY_CYCLE	Wheel temperature control duty cycle
32	AI_SAMPLE_TEMP	Sample temperature in degree C
34	AI_SAMPLE_PRESSURE	Sample pressure in PSIA
36	AI_BOX_TEMP	Box temperature in degree C
38	AI_PHOTO_TEMP_RAW	Detector temp drive in mV



N300, N300M

ADDRESS	TAG	DESCRIPTION
40	AI_PUMP_FLOW	Sample flow in CCM
42	AI_ATMOSPHERIC_PRESSURE	Atmospheric pressure in PA
Holding Registers		
0	CO_TARGET_SPAN_CONC_1	CO target span conc for range 1
2	CO_TARGET_SPAN_CONC_2	CO target span conc for range 2

APPENDIX B - N300 Interconnects

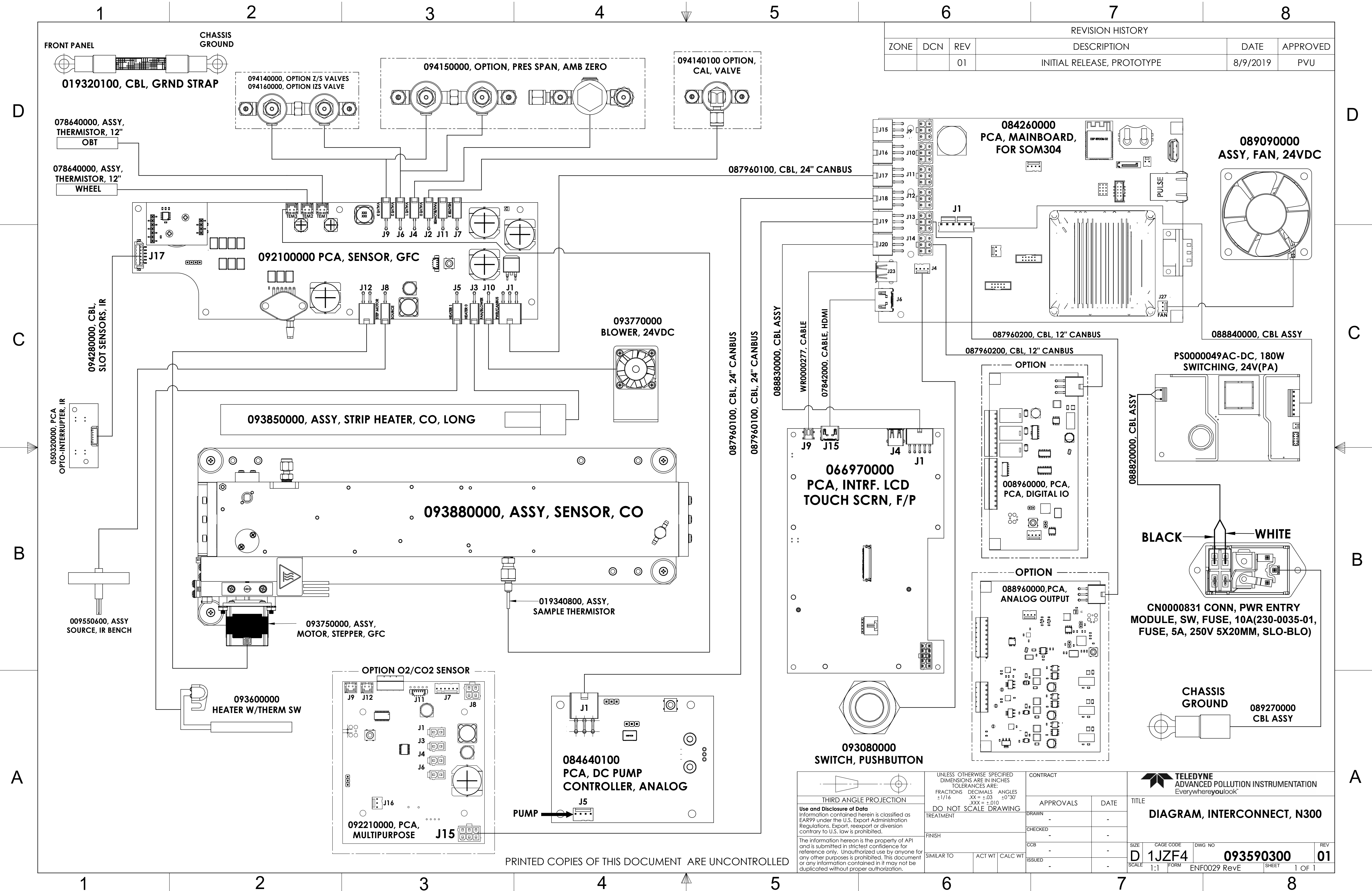

REVISION HISTORY					
ZONE	DCN	REV	DESCRIPTION	DATE	APPROVED
		01	INITIAL RELEASE, PROTOTYPE	8/9/2019	PVU

<p>THIRD ANGLE PROJECTION</p>	<p>UNLESS OTHERWISE SPECIFIED DIMENSIONS ARE IN INCHES TOLERANCES ARE:</p> <p>FRACTIONS DECIMALS ANGLES $\pm 1/16$ ± 0.03 $\pm 0^{\circ}30'$</p> <p>DO NOT SCALE DRAWING</p>	CONTRACT		<p>TITLE</p> <p>DIAGRAM, INTERCONNECT, N300</p>					
		APPROVALS	DATE		<p>TELEDYNE ADVANCED POLLUTION INSTRUMENTATION Everywhere you look</p>				
<p>Use and Disclosure of Data</p> <p>Information contained herein is classified as EAR99 under the U.S. Export Administration Regulations. Export, re-export or diversion contrary to U.S. law is prohibited.</p> <p>The information herein is the property of API and is submitted in strictest confidence for reference only. Unauthorized use by anyone for any other purposes is prohibited. This document or any information contained in it may not be duplicated without proper authorization.</p>	TREATMENT	DRAWN	-	<p>SIZE</p> <p>D 1JZF4</p>	<p>CAGE CODE</p> <p>093590300</p>	<p>DWG NO</p> <p>093590300</p>	<p>REV</p> <p>01</p>		
FINISH	ISSUED	CCB	-	SCALE	1:1	FORM	ENF0029 RevE	SHEET	1 OF 1

PRINTED COPIES OF THIS DOCUMENT ARE UNCONTROLLED

APPENDIX B - N300M Interconnects

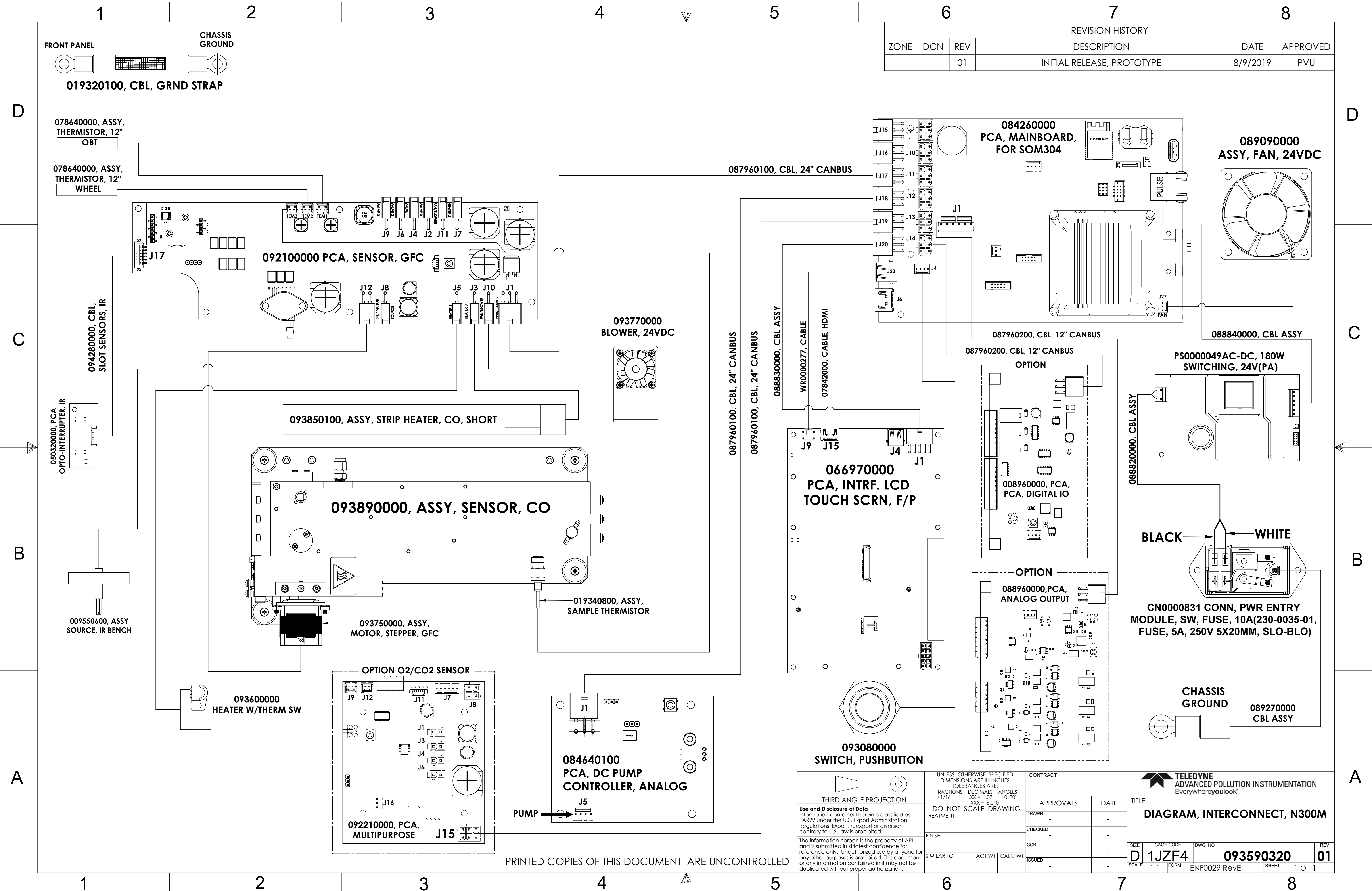

REVISION HISTORY					
ZONE	DCN	REV	DESCRIPTION	DATE	APPROVED
		01	INITIAL RELEASE, PROTOTYPE	8/9/2019	PVU

<p>THIRD ANGLE PROJECTION</p>	<p>UNLESS OTHERWISE SPECIFIED DIMENSIONS ARE IN INCHES TOLERANCES ARE:</p> <p>FRACTIONS DECIMALS ANGLES $\pm 1/16$ ± 0.03 $\pm 0^{\circ}30'$ $.XXX = \pm 0.10$</p> <p>DO NOT SCALE DRAWING</p>	CONTRACT		<p>TITLE</p> <p>DIAGRAM, INTERCONNECT, N300M</p>			
		APPROVALS	DATE		<p>TELEDYNE ADVANCED POLLUTION INSTRUMENTATION Everywhere you look</p>		
<p>Use and Disclosure of Data</p> <p>Information contained herein is classified as EAR99 under the U.S. Export Administration Regulations. Export, re-export or diversion contrary to U.S. law is prohibited.</p> <p>The information herein is the property of API and is submitted in strictest confidence for reference only. Unauthorized use by anyone for any other purposes is prohibited. This document or any information contained in it may not be duplicated without proper authorization.</p>	TREATMENT	DRAWN	-	<p>SIZE</p> <p>D 1JZF4</p>	<p>CAGE CODE</p> <p>093590320</p>	<p>DWG NO</p> <p>093590320</p>	<p>REV</p> <p>01</p>
FINISH	ISSUED	SCALE	FORM	ENF0029 RevE	SHEET	1 OF 1	

PRINTED COPIES OF THIS DOCUMENT ARE UNCONTROLLED