



## **MODEL 452 PROCESS OZONE SENSOR**

©Teledyne Instruments  
Advanced Pollution Instrumentation Division  
(T-API)  
9970 Carroll Canyon Road  
San Diego, CA 92131-1106

TOLL-FREE: 800-324-5190  
TEL: +1 858-657-9800  
FAX: +1 858-657-9816  
E-MAIL: [api-sales@teledyne.com](mailto:api-sales@teledyne.com)  
WEB SITE: [www.teledyne-api.com](http://www.teledyne-api.com)

## SAFETY MESSAGES



### NOTE

The M452 contains no user serviceable parts.



### CAUTION

There is risk of dangerous UV exposure when the cover is removed from the sensor. Take necessary precautions to avoid exposure.



### CAUTION

High voltages exist inside the sensor. Please use caution when sensor cover is removed.



# TABLE OF CONTENTS

SAFETY MESSAGES .....	I
TABLE OF CONTENTS .....	III
LIST OF FIGURES .....	V
LIST OF TABLES .....	V
WARRANTY POLICY .....	VII
<b>1 PRODUCT DESCRIPTIONS.....</b>	<b>1-1</b>
1.1 M452 PROCESS OZONE SENSOR .....	1-1
1.2 M452 HIGH PURITY PROCESS OZONE SENSOR.....	1-1
<b>2 SPECIFICATIONS .....</b>	<b>2-1</b>
2.1 MECHANICAL SPECIFICATIONS .....	2-1
2.2 PERFORMANCE SPECIFICATIONS .....	2-2
2.3 OPERATING LIMITS .....	2-2
2.4 ELECTRICAL SPECIFICATIONS .....	2-2
2.5 CALIBRATION REFERENCE .....	2-2
2.6 PRESSURE DROP.....	2-3
2.7 OPTIONS.....	2-4
2.7.1 AC Power Adapter.....	2-4
2.7.2 Ozone Destructor (1/4" Tube Fittings).....	2-4
<b>3 THEORY OF OPERATION .....</b>	<b>3-1</b>
<b>4 INSTALLATION.....</b>	<b>4-1</b>
4.1 UNPACKING .....	4-1
4.2 MECHANICAL INSTALLATION.....	4-1
4.3 ELECTRICAL CONNECTIONS .....	4-1
4.3.1 Power Supply.....	4-2
4.3.2 Analog Output.....	4-3
4.3.3 Zero Calibration Input.....	4-3
4.3.4 Status Outputs.....	4-4
4.3.5 RS232/485 Interface .....	4-5
4.4 GAS CONNECTIONS.....	4-6
4.5 START-UP AND CALIBRATION PROCEDURE.....	4-7

<b>5 SENSOR AND SYSTEM TROUBLESHOOTING .....</b>	<b>5-1</b>
5.1 STATUS LED'S.....	5-1
5.2 STATUS OUTPUTS.....	5-2
5.3 SENSOR O.K.....	5-2
5.4 INVALID READING.....	5-3
5.5 LAMP LOW .....	5-3
5.6 CELL DIRTY .....	5-4
5.7 STATUS OUTPUT SUMMARY TABLE .....	5-4

## LIST OF FIGURES

FIGURE 2-1: M452A HIGH PURITY OZONE SENSOR.....	2-1
FIGURE 2-2: PRESSURE DROP VS. FLOW (HIGH PURITY VERSION).....	2-3
FIGURE 4-1: ELECTRICAL CONNECTIONS .....	4-2
FIGURE 4-2: DIGITAL OUTPUT CONNECTIONS.....	4-4

## LIST OF TABLES

TABLE 5-1: STATUS OUTPUTS.....	5-2
TABLE 5-2: STATUS OUTPUT TRUTH TABLE .....	5-4



# WARRANTY POLICY

## ADVANCED POLLUTION INSTRUMENTATION DIVISION *02024c*

Prior to shipment, Teledyne API equipment is thoroughly inspected and tested. Should equipment failure occur, Teledyne API assures its customers that prompt service and support will be available.

### COVERAGE

After the warranty period and throughout the equipment lifetime, Teledyne API stands ready to provide on-site or in-plant service at reasonable rates similar to those of other manufacturers in the industry. All maintenance and the first level of field troubleshooting are to be performed by the customer.

### NON-API MANUFACTURED EQUIPMENT

Equipment provided but not manufactured by Teledyne API is warranted and will be repaired to the extent and according to the current terms and conditions of the respective equipment manufacturers warranty.

### GENERAL

Teledyne API warrants each Product manufactured by Teledyne API to be free from defects in material and workmanship under normal use and service for a period of one year from the date of delivery. All replacement parts and repairs are warranted for 90 days after the purchase.

If a Product fails to conform to its specifications within the warranty period, Teledyne API shall correct such defect by, in Teledyne API's discretion, repairing or replacing such defective Product or refunding the purchase price of such Product.

The warranties set forth in this section shall be of no force or effect with respect to any Product: (i) that has been altered or subjected to misuse, negligence or accident, or (ii) that has been used in any manner other than in accordance with the instruction provided by Teledyne API or (iii) not properly maintained.



THE WARRANTIES SET FORTH IN THIS SECTION AND THE REMEDIES THEREFORE ARE EXCLUSIVE AND IN LIEU OF ANY IMPLIED WARRANTIES OF MERCHANTABILITY, FITNESS FOR PARTICULAR PURPOSE OR OTHER WARRANTY OF QUALITY, WHETHER EXPRESSED OR IMPLIED. THE REMEDIES SET FORTH IN THIS SECTION ARE THE EXCLUSIVE REMEDIES FOR BREACH OF ANY WARRANTY CONTAINED HEREIN. TELEDYNE API SHALL NOT BE LIABLE FOR ANY INCIDENTAL OR CONSEQUENTIAL DAMAGES ARISING OUT OF OR RELATED TO THIS AGREEMENT OF TELEDYNE API'S PERFORMANCE HEREUNDER, WHETHER FOR BREACH OF WARRANTY OR OTHERWISE.

**TERMS AND CONDITIONS**

All units or components returned to Teledyne API should be properly packed for handling and returned freight prepaid to the nearest designated Service Center. After the repair, the equipment will be returned, freight prepaid.

# 1 Product Descriptions

## 1.1 M452 Process Ozone Sensor

The Teledyne API M452 is a microprocessor-based sensor for measuring the concentration of gaseous ozone in processes such as semiconductor wafer fabrication, water treatment, and ozone research. The M452 can be used as a full flow process sensor or as a sensor to monitor a small flow of gas diverted from a process stream.

The M452 features a standard 0-5 volt analog signal for reporting process concentration as well as 4 digital status outputs for sensor diagnostics. A bi-directional serial interface is also provided for computer control.

The M452 operates from an external +15 vdc power source.

## 1.2 M452 High Purity Process Ozone Sensor

The M452A High Purity Process Ozone Sensor includes a 316L manifold with a 10Ra finish. ¼" VCR™ face seal fittings are standard.

INTENTIONALLY BLANK

## 2 Specifications

Note: All specifications contained herein are subject to change without notice. Please contact Teledyne API to obtain the current specifications.

### 2.1 Mechanical Specifications

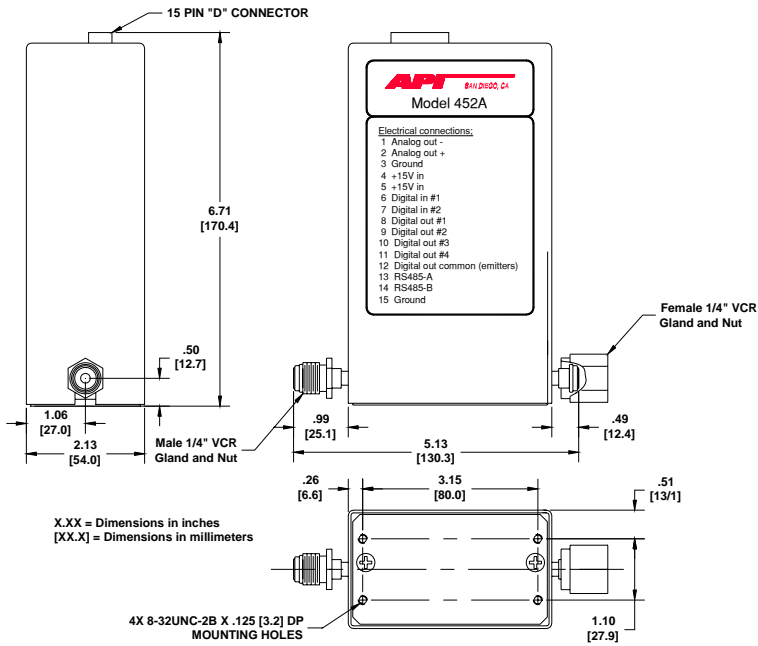

**Figure 2-1: M452A High Purity Ozone Sensor**

Weight:	2.8 lbs. (1.27 kg)
Surface Finish:	M452 - 32 $\mu$ inch Ra M452A - 10 $\mu$ inch Ra
Fittings:	M452 - 1/4" Gyrolok™ M452A - 1/4" VCR™
Wetted Materials:	316L Stainless Steel, Sapphire, Virgin PTFE

## **2.2 Performance Specifications**

Accuracy:	±1% of Full Scale.
Repeatability:	1% of Full Scale
Response Time:	2 sec. To 95%
Zero Drift:	1% Full Scale/month (non –cumulative)

## **2.3 Operating Limits**

Measurement Range:	5, 10, 15, 20% w/w 25, 50, 100, 200, 400 g/Nm <sup>3</sup>
Proof pressure:	115 psia
Flow:	0.1-5.0 LPM (See Figure 2-2)
Temperature range:	5 to 45 °C
Warm-Up Period:	15 minutes

## **2.4 Electrical Specifications**

Power Input:	+15 volts ±1.0 volt (1.0A maximum)
Analog Output:	0-5V Full Scale
Zero Cal:	Contact Closure Input
Digital Outputs:	Sensor OK, Invalid Reading, Lamp Low, Cell Dirty
Serial Data Interface:	RS232 or RS485, Half-Duplex, 9600 Baud

## **2.5 Calibration Reference**

Span Calibration:	Traceable to Buffered KI laboratory calibration
Standard Temperature and Pressure (g/Nm <sup>3</sup> only):	0°C and 760 mmHg

## 2.6 Pressure Drop

Figure 2-2 below shows the approximate pressure drop from the inlet fitting to the outlet fitting as a function of volumetric flow rate.

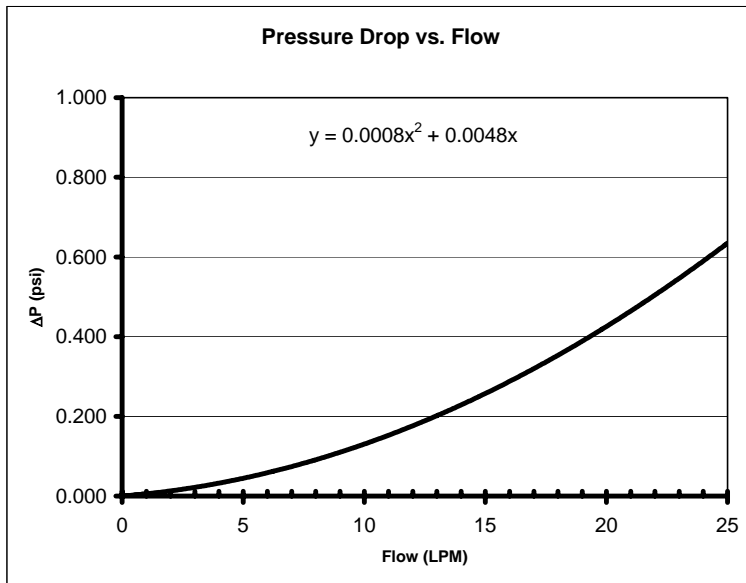

Figure 2-2: Pressure Drop vs. Flow (High Purity Version)

## **2.7 Options**

The M452 is available with the following options:

### **2.7.1 AC Power Adapter**

This option consists of a Universal Input (100-240 VAC, 50-60Hz) Power Adapter with a standard IEC320 modular AC receptacle. A North American standard 3 prong power cord is also provided.

### **2.7.2 Ozone Destructor (1/4" Tube Fittings)**

This option consists of an external catalytic Ozone Destructor for connecting to the gas outlet of the M452. The Ozone Destructor is provided with 1/4" compression tube fittings. When the Ozone Destructor is used in conjunction with the M452, the gas flow rate must be limited to a maximum of 1.0 L/min.

### 3 Theory of Operation

The detection of ozone molecules is based on absorption of 254 nm UV light due to an internal electronic resonance of the O<sub>3</sub> molecule. The Model 452 uses a mercury lamp constructed so that a large majority of the light emitted is at the 254 nm wavelength. Light from the lamp shines through an absorption cell through which the sample gas being measured is passed. The ratio of the intensity of light passing through the gas to a reference measurement, which does not pass through the gas, forms the ratio I/I<sub>o</sub>. This ratio forms the basis for the calculation of the ozone concentration.

The Beer-Lambert equation, shown below, calculates the concentration of ozone from the ratio of light intensities.

$$C_{O_3} = -\frac{1}{\alpha \times \ell} \times \frac{T}{273^\circ \text{K}} \times \frac{14.695 \text{ psi}}{P} \times \ln \frac{I}{I_o}$$

Where:

- I = Intensity of light passed through the sample
- I<sub>o</sub> = Intensity of light through sample free of ozone
- α = Absorption coefficient
- ℓ = Path length
- C<sub>O<sub>3</sub></sub> = Concentration of ozone
- T = Sample temperature in degrees Kelvin
- P = Pressure in pounds per square inch (absolute)

As can be seen the concentration of ozone depends on more than the intensity ratio. Temperature and pressure influence the density of the sample. The density changes the number of ozone molecules in the absorption cell, which impacts the amount of light, removed from the light beam. These effects are addressed by directly measuring temperature and pressure and including their actual values in the calculation. The absorption coefficient is a number that reflects the inherent ability of ozone to absorb 254 nm light. Lastly, the absorption path length determines how many molecules are present in the column of gas in the absorption cell.



The intensity of light is converted into a voltage by the detector/preamp module. The voltage is converted into a number by a voltage-to-frequency (V/F) converter capable of 80,000 count resolution. The digitized signal, along with the other variables, is used by the CPU to compute the concentration of ozone using the above formula.

## 4 Installation

### 4.1 Unpacking

Upon receiving the M452 please verify that no apparent shipping damage has occurred. If damage has occurred please advise shipper first, then Teledyne API.

### 4.2 Mechanical Installation

Mount the M452 to a stable platform using four #8-32UNC screws. See Figure 2-1 for mounting hole dimensions.



#### NOTE

**If the mounting platform is non-conductive or not connected to earth ground, then a separate connection to earth ground should be made using one of the mounting screws. Failure to provide a proper earth ground connection may make the M452 susceptible to electrical interference from external sources.**

### 4.3 Electrical Connections

Electrical connections are made to the M452 using the 15 pin D-Sub connector on the top of the device. Figure 4-1 shows the pin-out of the 15-pin connector and typical connections.

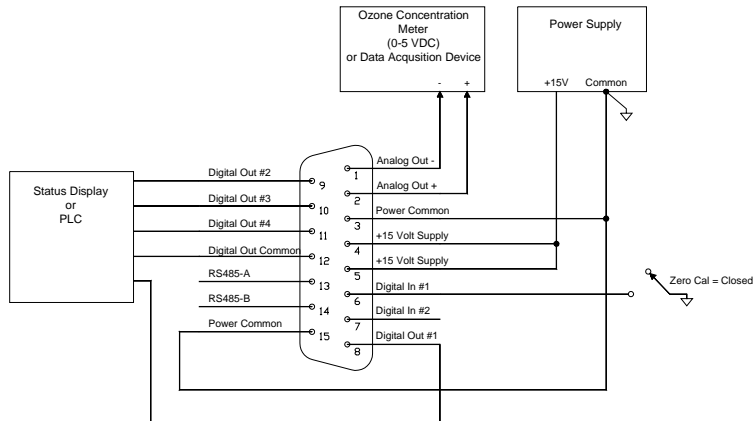

Figure 4-1: Electrical Connections

### 4.3.1 Power Supply

The M452 requires a +15 VDC power source capable of supplying 1.0 A. DC power can be connected through the male DB-15 connector or through the coaxial power jack. The coaxial power jack is configured so that the ground connection is on the outside (shield) and the +15V connection is on the center pin.

If power is to be supplied through the DB-15 connector, the positive terminal of the power supply should be connected to pins 4 and 5 on the 15-pin connector and the common terminal should be connected to pins 3 and 15.

If the optional AC Power Adapter is used to provide power, it should be connected to the coaxial power connector adjacent to the DB-15 connector on the top of the M452. Use only the approved AC Power Adapter provided by Teledyne API.

### **4.3.2 Analog Output**

The analog output is a 0-5 volt signal representing the ozone concentration measured by the sensor. The output is scaled to the concentration range that the sensor has been set to measure. Check the serial number label on the M452 to determine the concentration range.

For best performance, the analog output should be connected to a voltmeter or A/D converter with a differential input and a minimum input impedance of 2K $\Omega$ .

### **4.3.3 Zero Calibration Input**

The zero calibration input is located on Digital Input #1. To zero the M452, Digital Input #1 should be connected to the power common for at least 1 second. This can be accomplished using a Normally Open switch or relay.

### 4.3.4 Status Outputs

The M452 has four digital status outputs for indicating error status and when operational parameters have moved out of normal limits. These outputs are in the form of opto-isolated open-collector transistors. They can be used to drive status LED's on a display panel or interface to a digital device such as a Programmable Logic Controller (PLC).

Figure 4-2 below shows the most common way of connecting the digital outputs to an external device such as PLC. Note: Most devices, such as PLC's, have internal provision for limiting the current that the input will draw from an external device. When connecting to a unit that does not have this feature, external dropping resistors must be used to limit the current through the transistor output to 50mA or less.

See Section 1 for details on using the Status Outputs for diagnosing sensor and system-level malfunctions.

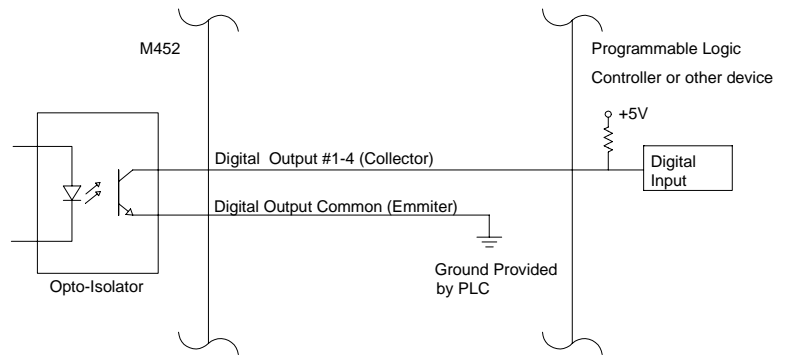

**Figure 4-2: Digital Output Connections**

### **4.3.5 RS232/485 Interface**

The M452 features a bi-directional digital serial interface that can be used for sensor control and data acquisition. Please contact Teledyne API for documentation on the use of the RS232/485 interface.

## 4.4 Gas Connections

Gas connections to the M452 are made using ¼" compression tube fittings (M452) or ¼" VCR™ face seal fittings (M452A.) The ¼" compression fittings can be used with ¼" O.D. Stainless Steel or Teflon™ tubing. The M452 is not sensitive to flow direction; it does not matter which of the two fittings is used as the gas inlet.

To avoid contamination of the optical cell in the M452, ensure that all tubing upstream of the M452 is properly cleaned and purged **before** the M452 is installed.

In order to achieve an acceptable response time and to avoid sample degradation, the system should be set up so that a minimum flow rate of 0.1 LPM is established through the M452. If long tubing runs are used between the measurement point and the M452, then higher flow rates should be used to avoid sample degradation. Appropriate tests should be conducted to determine minimum flow requirements.

## **4.5 Start-Up and Calibration Procedure**

1. Verify that the proper electrical connections have been made (See Section 4.3) and apply power to the M452. Allow the M452 to warm up for at least 15 minutes.
2. Purge the M452 with zero gas (usually oxygen) at a minimum flow rate of 0.1 LPM for at least 2 minutes.
3. Check that the Status Outputs (See Section 4.3.4) are in their normal states and no errors are indicated.
4. Close the zero calibration input (See Section 4.3.3) for a minimum of 1 second to perform the automatic zero calibration.
5. Re-check the Status Outputs to ensure that no errors are indicated.
6. Check the voltage on the analog output (See Section 4.3.2) and verify that it reads  $0.000 \pm 0.010$  volts.
7. The M452 is now ready for operation.





## 5 Sensor and System Troubleshooting

This chapter gives guidelines for diagnosing system and sensor malfunctions using the four digital Status Outputs provided by the M452. All troubleshooting should be done after the M452 has been turned on and allowed to warm up for at least 15 minutes.

### 5.1 Status LED's

On the top of the M452 are five status LED's.

The Status LED labeled 'CPU STATUS' is used to verify the status of the CPU inside the M452. This LED should blink on and off continuously while the sensor is on. If this LED stops blinking while power is applied to the sensor, a CPU failure is indicated.

The other four Status LED's on the M452 exactly mirror the four Status Outputs described in the following sections.

## 5.2 Status Outputs

Table 5-1 below describes the function of the status outputs. More details as to the meaning of the status outputs are described in the following sections.

**Table 5-1: Status Outputs**

Output #	Name	On State	Off state
1	Sensor O.K.	Normal State	Reference or Measure > 4995mV; Reference < 1000mV
2	Invalid Reading	Pressure > 45 psia, Negative Ozone Concentration	Normal State
3	Lamp Low	Reference Detector < 600mV	Normal State
4	Cell Dirty	Measure/Reference ratio < 0.5 (zero gas)	Normal State

## 5.3 Sensor O.K.

The normal state for the Sensor O.K. output is ON. During the warm-up period on start-up this output will stay off until the UV lamp reaches a minimum intensity. If this output remains off after the 15 minute warm-up period, or goes off during normal operation, then the M452 is in need of servicing.

If the Sensor O.K. output turns off AND the Lamp Low output is on, this indicates that the lamp intensity has below the minimum level required for proper operation.

If the Sensor O.K. output turns off and the Lamp Low output is also off, then one of the analog voltages in the sensor has exceeded the range of the internal A/D converter. Adjustment by qualified service personnel is required.

## **5.4 Invalid Reading**

The normal state for the Invalid Reading output is OFF. If this output turns on, this indicates that the M452 is still operational, but a system fault or calibration fault exists that may make the current ozone reading invalid.

The Invalid Reading output is turned on for any of the following conditions:

1. When the measured pressure in the M452 exceeds 45 psia.
2. When the measured concentration has exceeded the full-scale concentration range of the sensor. Check the serial number tag for the full-scale concentration range.
3. The sensor is indicating an excessive negative reading.

## **5.5 Lamp Low**

The normal state for the Lamp Low output is OFF. If this output turns on, this indicates that the UV lamp intensity as measured by the reference detector has dropped below 600mV.

If the Lamp Low output turns ON and the Sensor O.K. output is ON, this indicates that the lamp intensity is still adequate for measurement, but adjustment should be made when possible.

If the Lamp Low output turns ON and the Sensor O.K. output is OFF, this indicates a failure condition and accurate measurement is no longer possible.

## 5.6 Cell Dirty

The normal state for the Cell Dirty output is OFF. If this output turns on, then the ratio of the measure detector to the reference detector (at zero) is  $< 0.5$ . This value is calculated when the zero calibration is performed.

When this output is on, it indicates a loss of optical transmission through the windows in the absorption cell or a calibration fault.

## 5.7 Status Output Summary Table

Table 5-2 below is a logic truth table summarizing the recommended actions based on the states of the four status outputs. A '1' indicates the output is ON, a '0' indicates the output is OFF, and 'X' indicates the output is in either state.

**Table 5-2: Status Output Truth Table**

Sensor OK	Invalid Reading	Lamp Low	Cell Dirty	Actions
1	0	0	0	Normal operation, no action required
0	X	X	X	Service required
1	1	X	X	Check Pressure > 45 psia Verify that concentration has not exceeded full scale range of sensor. Calibrate at Zero.
1	X	1	X	Lamp adjustment useful, though not required
1	X	X	1	Calibrate at zero Clean Cell

INTENTIONALLY BLANK